

Safety Defect and Noncompliance Report Guide for Equipment  
**PART 573 Defect and Noncompliance Responsibility and Reports<sup>1</sup>**

On 10-17, 2006, KZRVL,LP decided that (a defect which relates to motor vehicle safety)(a noncompliance with Federal Motor Vehicle Safety Standard No. \_\_\_\_\_) exists in items of motor vehicle equipment listed below, and is furnishing notification to the National Highway Traffic Safety Administration in accordance with 49 CFR Part 573 Defect and Noncompliance Responsibility and Reports.

Date this report was prepared: 10-17-06

Furnish the manufacturer's identification code for this recall (if applicable): 06E-029

1. Identify the full corporate name of the fabricating manufacturer/brand name/trademark owner of the recalled item of equipment. If the recalled item of equipment is imported, provide the name and mailing address of the designated agent as prescribed by 49 U.S.C. §30164.

KZRVL,LP 0985N 900w Shipshewana, IN 46565

Identify the corporate official, by name and title, whom the agency should contact with respect to this recall.

Delbert Miller Compliance Manager

Telephone Number: (260) 768-2010 Fax No.: (260) 768-7629

Name and Title of Person who prepared this report.

Delbert Miller  
Compliance Manager

Signed:



<sup>1</sup> Each manufacturer must furnish a report, to the Associate Administrator for Enforcement, for each defect or noncompliance condition which relates to motor vehicle safety.

This guide was developed from 49 CFR Part 573, "Defect and Noncompliance Responsibility and Reports" and also outlines information currently requested. Any questions, please consult the complete Part 573 or contact Mr. George Person at (202) 366-5210 or by FAX at (202) 366-7882.

**I. Identify the Recalled Items of Equipment**

2. Identify the Items of Equipment Involved in this Recall, for each make and model or applicable item of equipment product line (provide illustrations or photographs as necessary to describe the item of equipment), provide:

Generic name of the item:

Make: Escalade Model: 36K5B

Part Number: \_\_\_\_\_ Size:

Function:

Other information which characterizes/distinguishes the items of equipment to be recalled:

Disc Brake option - see attached Exhibit A for detailed identification of the (4) 36K5B Escalades for recall.

Make: Escalade Model: 36SKB

Part Number: \_\_\_\_\_ Size:

Function:

Other information which characterizes/distinguishes the items of equipment to be recalled:

Disc Brake Option - see attached Exhibit A for detailed identification of the (5) 36SKB Escalades for recall.

Make: Escalade Model: 36CKB

Part Number: \_\_\_\_\_ Size:

Function:

Model Years Involved:

Other information which characterizes/distinguishes the items of equipment to be recalled:

Disc Brake Option - see attached Exhibit A for detailed identification of the (4) 36CKB Escalades for recall

Make: Escalade Model: 37RKB

Part Number: \_\_\_\_\_ Size:

Function:

Other information which characterizes/distinguishes the items of equipment to be recalled:

Disc Brake Option - see attached Exhibit A for detailed identification of the (3) 37RKB Escalades for recall.

Cont. →

Generic name of the item:

Make: Escalade Model: 41CK5

Part Number: \_\_\_\_\_ Size:

Function:

Other information which characterizes/distinguishes the items of equipment to be recalled:

Disc Brake Option - see attached Exhibit A for detailed list of the (6) 41CK5 Escalades for recall

Make: Escalade Model: 41SK5

Part Number: \_\_\_\_\_ Size:

Function:

Other information which characterizes/distinguishes the items of equipment to be recalled:

Disc Brake Option - see attached Exhibit A for detailed list of the (2) 41SK5 Escalades for Recall

Make: Montego Bay Model: 41CK5

Part Number: \_\_\_\_\_ Size:

Function:

Model Years Involved:

Other information which characterizes/distinguishes the items of equipment to be recalled:

Disc Brake Option - see attached Exhibit A for detailed list of the (1) 41CK5 Montego Bay for Recall

Make: \_\_\_\_\_ Model:

Part Number: \_\_\_\_\_ Size:

Function:

Other information which characterizes/distinguishes the items of equipment to be recalled:

\_\_\_\_\_  
\_\_\_\_\_

Identify the approximate percentage of the production of all the recalled models manufactured by your company between the inclusive dates of manufacture provided above, that the recalled model population represents. For example, if the recall involved Widgets equipped with certain items of equipment from January 1, 1996, through April 1, 1997, then what was the percentage of the recalled Widgets of all Widgets manufactured during that time period.

## II. Identifying the Recall Population

3. Furnish the total number of items of equipment recalled potentially containing the defect or noncompliance.

Items Model	Year	Number of Potentially
<u>Involved</u>		
Escalade (36KSB, 37RKB, 41CKS, 41SKS, 36SKB, 36CKB)	2006	17
Escalade (41CKS, 37RKB, 36KSB, 36CKB)	2007	7
Montego Bay (41CKS)	2007	1

Total Number Potentially Affected by the Recall: 25

4. Furnish the approximate percentage of the total number of items of equipment estimated to actually contain the defect or noncompliance:

2006

Total units	371
Recall units	17
	71%

2007

Total units	206	YTD
Recall units	8	
	71%	

Identify and describe how the recall population was determined--in particular how the recalled models were selected and the basis for the beginning and final dates of manufacture of the recalled items of equipment:

*Recall item was optional equipment - reviewed all orders/build sheets during affected time period*

**III. Describe the Defect or Noncompliance**

5. Describe the defect or noncompliance. The description should address the nature and physical location of the defect or noncompliance. Illustrations should be provided as appropriate.

Caliper mounting nut separating from its bolt during the brake bleeding operation. The brake bleeding is done prior to shipping unit to dealerships and retail customers.

**Describe the cause(s) of the defect or noncompliance condition.**

We have found that the caliper mounting locknut can yield during the installation process at higher torque levels.

**Describe the consequence(s) of the defect or noncompliance condition.**

The yielded mounting caliper nut does not properly engage onto the bolt and allows the caliper to come apart and create a loss of braking.

**Identify any warning which can (a) precede or (b) occur.**

The failure occurs at the during the brake bleeding operation.

**If the defect or noncompliance is in a component or assembly purchased from a supplier, identify the supplier by corporate name and address.**

Dexter Axel Company  
2900 Industrial Pkwy East  
Elkhart, IN 46515

**Identify the name and title of the chief executive officer or knowledgeable representative of the supplier:**

Charles M. Vaughn, Jr. VP of Technology

#### **IV. Provide the Chronology in Determining the Defect/Noncompliance**

*If the recall is for a defect, complete item 6, otherwise item 7.*

**6. With respect to a defect, furnish a chronological summary (including dates) of all the principle events that were the basis for the determination of the defect. The summary should include, but not be limited to, the number of reports, accidents, injuries, fatalities, and warranty claims.**

**7. With respect to a noncompliance, identify and provide the test results or other data (in chronological order and including dates) on which the noncompliance was determined.**

#### **V. Identify the Remedy**

**8. A description of the manufacturer's program for remedying the defect or noncompliance. This program shall include a plan for reimbursing an owner or purchaser who incurred costs to obtain a remedy for the problem addressed by the recall within a reasonable time in advance of the manufacturer's notification of owners, purchasers and dealers, in accordance with §573.13 of this part. A manufacturer's plan may incorporate by reference a general reimbursement plan it previously submitted to NHTSA, together with information specific to the individual recall. Information required by §573.13 that is not in a general reimbursement plan shall be submitted in the manufacturer's report to NHTSA under this section. If a manufacturer submits one or more general reimbursement plans, the manufacturer shall update each plan every two years, in accordance with §573.13. The manufacturer's remedy program and reimbursement plans will be available for inspection by the public at NHTSA headquarters.**

Dexter Axle has redesigned the caliper mounting nut so that it is more robust by increasing the thread engagement. Replacement parts along with instructions on how to replace hardware has been sent to the affected OEM's. Dexter Axle will reimburse the OEM's for the costs associated with replacing the caliper mounting hardware.

**9. Furnish a description of the manufacturer's remedy for the defect or noncompliance. Clearly describe the differences between the recall condition and the remedy.**

See attached repair instructions

Clearly describe the distinguishing characteristics of the remedy component/assembly versus the recalled component/assembly.

The new caliper mounting nut is larger and provides additional thread engagement, this feature makes the fastener system more robust and more resistant to yielding.

Identify and describe how and when the recall condition was corrected in production. If the production remedy was identical to the recall remedy in the field, so state. If the product was discontinued, so state.

New product is being made with new designed nut. This remedy is identical to the field remedy.

**VI. Identify the Recall Schedule**

10. Furnish a schedule or agenda (with specific dates) for notification to other manufacturers, dealers/retailers, and purchasers. Please, identify any foreseeable problems with implementing the recall.

All affected units have been identified. Letters will be forwarded to all dealers (unsold stock units) and retail consumers for notification and remedies.

**VII. Furnish Recall Communications**

11. Furnish a final copy of all notices, bulletins, and other communications that relate directly to the defect or noncompliance and which are sent to more than one manufacturer, distributor, or purchaser. This includes all communications (including both original and follow-up) concerning this recall from the time your company determines the defect or noncompliance condition on, not just the initial notification. *A DRAFT copy of the notification documents should be submitted to this office by Fax (202-366-7882) for review prior to mailing.*

**Note: These documents are to be submitted separately from those provided in accordance with Part 579.5 requirements.**

# Exhibit A

Dexter Axle Recall For KZ Plant 6						Retail	Axles
4EZFS41396S028900	107-6	Tiara RV	3420 Cassopolis ST	Elkhart Indiana 46514	1-574-266-2136	Lazechko	3
4EZFS41396S029142	126-6	Arrow RV	2892 Gulf To Bay	Clearwater Florida 33759	1-727-796-7336	Ford	3
4EZFS36206S029363	142-6	Kings Campers	5507 Lilac Ave	Wausau Wisconsin 54401	1-715-355-5556	Guissepe	2
4EZFS362X6S029368	147-6	Freds RV	41777 SE Hwy 26	Sandy Oregon 97055	1-503-826-8888	Stock	2
4EZFS36276S029375	154-6	Freds RV	41777 SE Hwy 26	Sandy Oregon 97055	1-503-826-8888	Stock	2
4EZFS36286S039848	181-6	Terrell Camping	Highway 150 E	Terrell North Carolina 28682	1-828-478-2651	Sutta	2
4EZFS36236S039868	201-6	Freds RV	41777 SE Hwy 26	Sandy Oregon 97055	1-503-826-8888	Stock	2
4EZFS37236S039870	203-6	Freds RV	41777 SE Hwy 26	Sandy Oregon 97055	1-503-826-8888	Stock	2
4EZFS41396S030176	217-6	Country Roads	1651 S Highway 160	Parumph Nevada 89048	1-775-751-9912	Berg	3
4EZFS36286S030180	221-6	Terrell Camping	Highway 150 E	Terrell North Carolina 28682	1-828-478-2651	Smith	2
4EZFS41366S030393	240-6	Tiara RV	3420 Cassopolis ST	Elkhart Indiana 46514	1-574-266-2136	Klining	3
4EZFS36286S030406	253-6	East End RV	89 Montauk Highway	Moriches New York 11940	1-631-878-0017	Perricone	2
4EZFS36266S041419	331-6	Country Roads	1651 S Highway 160	Parumph Nevada 89048	1-775-751-9912	Brumfield	2
4EZFS41346S041425	337-6	West Coast	85 Auto Center Drive	Pamona California 91766	1-909-625-1000	Paulus	3
4EZFS413X6S041154	312-6	Tiara RV	3420 Cassopolis ST	Elkhart Indiana 46514	1-574-266-2136	Burkhalter	3
4EZFS41366S041166	324-6	Leisure Tyme	1490 HWY 98 W	Mary Esther Florida 32569	1-850-581-0880		3
4EZFS37226S041156	314-6	Leisure Life	550 Sparrow Dr	Shepherdsville KY 40165	1-502-955-7169	Grooms	2
4EZFS41337S051705	373-6	Campers Inn K	146 Route 125	Kingston NH 03848	1-603-642-5555	Rymes	3
4EZFS36227S051955	377-6	Crown RV	31 River Street	East Ellijay GA 30539	1-706-635-3988		2
4EZFE362X7S051959	381-6	Freds RV	41777 SE Hwy 26	Sandy Oregon 97055	1-503-826-8888	Clauson	2
4EZFX41397S051967	389-6	Camptown RV	12856 Highway 70 W	Clayton NC 27520	1-919-553-7277	Gayton	3
4EZFE37267S051973	395-6	Roy's RV	RR4 Box 198	Elkins West Virginia 26241	1-304-636-1690		3
4EZFE36207S052442	433-6	Meek's RV	25355 N HWY 99	Acampo California 95220	1-209-366-1100	Burns	2
4EZFE36217S052448	439-6	Steve Driver	933 ST. Luc Blvd	ST Jean-Sur-Richelieu PQ	1-514-877-4944	Dion	2
4EZFE36217S052627	454-6	Rec World	117 Ferguson Road	Annapolis Maryland 21401	1-410-626-8226	Stein	2

## Brake Caliper Repair Instructions

1. Jack up trailer and secure on adequate capacity jack stands. Follow trailer manufactures recommendations for lifting and supporting the unit.
2. Remove the wheel from the hub, leaving the brake exposed.
3. Make sure hydraulic system is not pressurized during the hardware replacement.
4. Replace the four caliper mounting bolts and nuts with new supplied bolts and prevailing torque nuts.

**NOTE:** The bleeder fitting must be removed in order to replace one of the bolts. Carefully remove the fitting and cover the hole to prevent dirt from entering. After inserting the new bolt, re-install the bleeder fitting. **The system will not need to be re-bled if care is taken to prevent loss of fluid.** If excessive brake fluid is lost, the system should be re-bled according to the attached instructions.

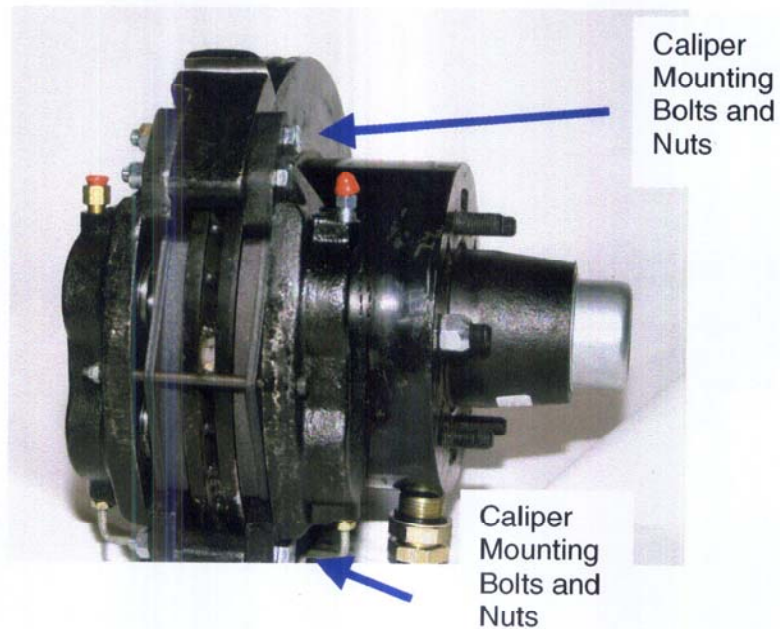

5. Torque all four nuts to 30 lb ft.
6. Remount the wheel. Start wheel nuts by hand to prevent cross threading.
7. Tighten wheel nuts in a "cross pattern" following the manufacturers recommendations for proper torque setting.
8. Spin wheel to ensure proper clearance between the wheel, crossover brake line and the rotor.

### **Bleeding and Brake Adjustment**

1. It typically is much easier to bleed the brakes with two people working together or use of a power-bleeding device.
2. Special care must be taken to insure that the Dexter E/H unit does not run out of brake fluid. Check the fluid level frequently during the bleeding process.
3. Block the wheels on the trailer and towing vehicle.
4. Loosen the bleed screw on the Dexter E/H unit and install plastic tubing onto the bleeder.
5. Immerse the free end of the plastic tubing in a clean container partially filled with brake fluid.
6. With eye protection on, open the bleeder screw one half turn on the Dexter E/H unit. Take care to protect you and the trailer from brake fluid expelled from the bleeder.
7. Activate the Dexter E/H unit by turning on the ignition switch and pressing on the brake pedal or the manual control on the in-cab controller.
8. Watch the free end of the bleeder hose for air bubbles escaping into the container.
9. Continue to bleed until the fluid becomes clear and free of bubbles.
10. Tighten the bleeder screw, turn off the Dexter E/H unit, and remove the plastic tubing from the bleeder screw. Bleeding of the actuator is now complete.
11. Install plastic tubing onto the bleeder screw of the wheel cylinder/caliper.
12. Immerse the free end of the plastic tube in a clean container partially filled with brake fluid.
13. Open the bleeder screw one half turn on the wheel cylinder/caliper farthest from the Dexter E/H unit. If towed vehicle has multiple axles, always start with the rear axle first.
14. To activate the Dexter E/H unit, turn the ignition switch on and press on the brake pedal.
15. Watch the free end of the bleeder hose for air bubbles escaping into the clear container. Continue to bleed the wheel cylinder/caliper until the fluid becomes clear and free of bubbles.

### CAUTION

**Do not run the Dexter E/H actuator without adequate brake fluid in the reservoir as it will damage the unit and void the warranty. Check all bleeder screws to ensure that they are securely closed and do not leak.**

16. Tighten the bleeder screw, turn off the Dexter E/H unit, and remove plastic tubing from the bleeder screw. Bleeding of the wheel cylinder/caliper is now complete.
17. Refill the Dexter E/H unit with brake fluid.
18. Continue the above process (steps 11 through 17) on the next farthest brake away from the actuator.
19. Repeat these steps until all the brakes have been bled.
20. New trailers with disc brakes should be bled at least twice and then a third time after a few hundred miles use. Any air in the brake system will cause brake delay with an E/H system.

[ date ]

[Dealer name]

**Reference: RECALL NO. XXX-XXX**

Dear [ manufacturer's name ] Dealer:

Dexter Axle has determined that a condition involving motor vehicle safety may exist in certain trailers produced by [ manufacturer's name ] between February, 2006 and approximately March , 2006.

The condition relates to trailers fitted with disc brakes. Some of the axles supplied to the trailer manufacturer from February, 2006 through March, 2006 may have caliper mounting bolts that are stripped. Insufficient clamp load between caliper and yoke can cause the caliper to disassemble and adversely affect the trailer's braking system.

The attached list of the affected trailers at your location was provided by the manufacturer. If any of these listed vehicles have already been delivered to the retail customer, please advise Dexter Axle immediately. Provide us with the name and address of the owner so that we may send proper notification of the recall. Dexter will provide replacement parts and reimburse you for reasonable repair costs.

Please service any vehicles still in your inventory, before delivery to the retail customer. Inspection and repair should be done in the following manner:

1. Jack up trailer and secure on adequate capacity jack stands. Follow trailer manufactures recommendations for lifting and supporting the unit.
2. Remove the wheel from the hub, leaving the brake exposed.
3. Make sure hydraulic system is not pressurized during the hardware replacement.
4. Replace the four caliper mounting bolts and nuts with new supplied bolts and "Keps" nuts

**NOTE:** The bleeder fitting must be removed in order to replace one of the bolts. Carefully remove the fitting and cover the hole to prevent dirt from entering. After inserting the new bolt, re-install the bleeder fitting. **The system will not need to be re-bled if care is taken to prevent loss of fluid.** If excessive brake fluid is lost, the system should be re-bled according to the attached instructions.

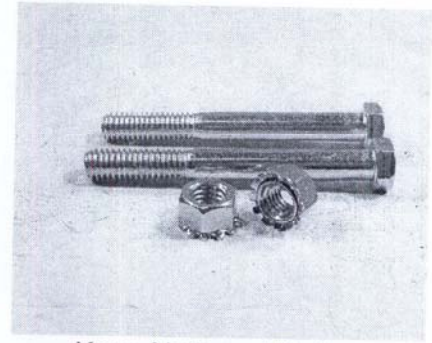
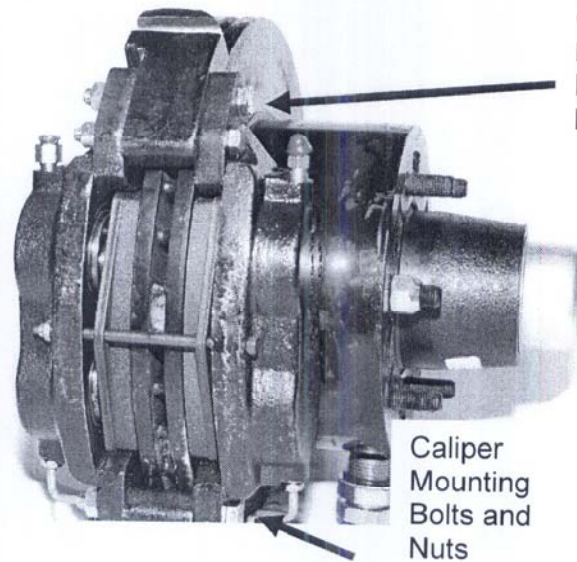

Keps Nuts and Bolts

5. Torque all four Keps nuts to 30 lb ft.
6. Remount the wheel. Start wheel nuts by hand to prevent cross threading.
7. Tighten wheel nuts in a "cross pattern" following the manufacturers recommendations for proper torque setting.
8. Spin wheel to ensure proper clearance between the wheel, crossover brake line and the rotor.

### Bleeding and Brake Adjustment

1. It typically is much easier to bleed the brakes with two people working together or use of a power-bleeding device.
2. Special care must be taken to insure that the Dexter E/H unit does not run out of brake fluid. Check the fluid level frequently during the bleeding process.
3. Block the wheels on the trailer and towing vehicle.
4. Loosen the bleed screw on the Dexter E/H unit and install plastic tubing onto the bleeder.
5. Immerse the free end of the plastic tubing in a clean container partially filled with brake fluid.
6. With eye protection on, open the bleeder screw one half turn on the Dexter E/H unit. Take care to protect you and the trailer from brake fluid expelled from the bleeder.
7. Activate the Dexter E/H unit by turning on the ignition switch and pressing on the brake pedal or the manual control on the in-cab controller.
8. Watch the free end of the bleeder hose for air bubbles escaping into the container.

9. Continue to bleed until the fluid becomes clear and free of bubbles.
10. Tighten the bleeder screw, turn off the Dexter E/H unit, and remove the plastic tubing from the bleeder screw. Bleeding of the actuator is now complete.
11. Install plastic tubing onto the bleeder screw of the wheel cylinder/caliper.
12. Immerse the free end of the plastic tube in a clean container partially filled with brake fluid.
13. Open the bleeder screw one half turn on the wheel cylinder/caliper farthest from the Dexter E/H unit. If towed vehicle has multiple axles, always start with the rear axle first.
14. To activate the Dexter E/H unit, turn the ignition switch on and press on the brake pedal.
15. Watch the free end of the bleeder hose for air bubbles escaping into the clear container. Continue to bleed the wheel cylinder/caliper until the fluid becomes clear and free of bubbles.

#### **CAUTION**

**Do not run the Dexter E/H actuator without adequate brake fluid in the reservoir as it will damage the unit and void the warranty. Check all bleeder screws to ensure that they are securely closed and do not leak.**

16. Tighten the bleeder screw, turn off the Dexter E/H unit, and remove plastic tubing from the bleeder screw. Bleeding of the wheel cylinder/caliper is now complete.
17. Refill the Dexter E/H unit with brake fluid.
18. Continue the above process (steps 11 through 17) on the next farthest brake away from the actuator.
19. Repeat these steps until all the brakes have been bled.
20. New trailers with disc brakes should be bled at least twice and then a third time after a few hundred miles use. Any air in the brake system will cause brake delay with an E/H system.

A flat rate of .5 hour/rack, .5 hour/caliper, .25 hour/axle bleed will be allowed for replacing the hardware of the disc brake axles.

Sincerely,

Charles M. Vaughn, Jr.  
VP of Technology  
Dexter Axle Company

Attachments:

Vehicle listing