

# WILSON TRAILER COMPANY

4400 So. Lewis Boulevard  
P.O. Box 2616  
Sioux City, Iowa 51106-0616  
Phone (712) 252-6500 Fax (712) 252-6510

January 25, 2006

061-024  
(8 Pages)

*Via Certified Mail*

Associate Administrator for Enforcement  
National Highway Transportation and Safety Administration  
400 - 7<sup>th</sup> Street S.W.  
Washington, DC 20590

RE: Notice of Possible Defect

Dear Administrator:

## REPORT TO NHTSA

1. Manufacturer's Name: Wilson Trailer Company
2. Vehicle Identification: certain 2003, 2004, 2005, and 2006 Wilson grain trailers manufactured from October 30, 2002, to May 1, 2005. Vehicles have been further identified by serial number and customer list.
3. Total Number of Vehicles Subject to Recall: 2,177.
4. Percentage of Trailers Estimated to be Defective: Less than 1% (nine trailers).
5. Description of Defect: The defect concerns the air ride suspension hanger weldment at the attachment point between the hanger and the subframe on two-axle steel tandem configurations. Weld failure can cause the suspension and axles to detach from the trailer frame and cause personal injury to persons outside the vehicle and property damage. See enclosed photos.
6. History of Events: Nine trailers manufactured within the time period have experienced some weld cracking in the area of concern. A determination of the cause reveals that the weld at the attachment point between the hanger and subframe needs an additional support gusset to strengthen the weldment.

Associate Administrator for Enforcement  
January 25, 2006  
Page Two

7. Description of Remedy: To remedy the defect, one must first inspect the area of concern for any cracking in the weld and repair the weld if cracking is present. In addition, a support gusset must be installed at the area of concern. Instructions as to how to remedy the problem will be provided by the manufacturer to both the customer and the service dealer. Also, the customer and dealer will be provided a toll-free number to contact the manufacturer. The process involves inspection, remedial repair as required, and installation of the support gusset.

Customers will be notified of the safety recall by first class mail on or before January 30, 2006.

8. Copies of Notices, etc.: See enclosed Safety Recall Notice with enclosures and dealer letter.

Respectfully submitted,



Bob McLarty  
Technical Service and Claims Manager

Enclosures: Safety recall notice to owner  
Photographs of area of concern with and without support gusset  
Dealer letter  
Drawing with repair instructions

(PROPOSED DEALER LETTER CONCERNING SAFETY RECALL NOTICE)

(Date)

(Dealer)

(Address)

(City and State)

RE: Notice of Possible Defect

Dear Sir:

Wilson Trailer Company has decided that a possible defect exists with certain 2003, 2004, 2005, and 2006 Wilson grain trailers manufactured from October 30, 2002, to May 1, 2005. Affected trailers are built with two-axle steel tandems. The defect concerns the attachment point between the air ride suspension hanger and the subframe. If the weldment at the attachment point fails, the hanger can separate from the trailer frame.

Your company has sold some of these trailers. Enclosed is a listing of your customers and serial numbers for the affected trailers. Wilson Trailer Company has notified these customers per the enclosed Safety Recall Notice. They have been given the option to contact you if they have questions. If contacted, please answer their questions.

Review the list of customers to confirm that they still own the serial number trailer on your list. If any of your customers have traded or sold the affected trailers, please advise Linda Kollbaum of the new owner and address, if available.

Wilson Trailer Company has determined that it is necessary to inspect the area of concern to determine whether the weld is cracked. If so, a repair will be necessary before any further remedial measure is performed. Finally, you will need to install a support gusset at that location per the enclosed drawing. All necessary parts will be shipped to you, and the inspection, repair, and installation will be at no cost to the customer. The total time to perform these tasks is estimated to be four hours. Repair invoices will be sent to my attention at Wilson Trailer Company. The description on the invoice should read "**Recall suspension hanger gussets to long members**".

In the event you have any of the affected trailers on your lot, you will need to inspect and take action outlined above. I will need to be notified of any such trailers on your lot.

Sincerely,

Bob McLarty  
Technical Service & Claims Manager

Enclosures: Customer Notice  
Customer List with serial numbers  
Photographs of suspension hanger with and without support gusset  
Drawing with repair instructions

(PROPOSED CUSTOMER NOTIFICATION LETTER CONCERNING SAFETY RECALL)

(Date)

(Customer)

(Address)

(City and State)

RE: Notice of Possible Defect  
Trailer Serial No.  
NHTSA I.D.

Dear Sir:

### **SAFETY RECALL NOTICE**

This notice is sent to you in accordance with the National Traffic and Motor Vehicle Safety Act. Wilson Trailer Company has decided that a defect which relates to motor vehicle safety exists in certain 2003, 2004, 2005, and 2006 Wilson grain trailers manufactured from October 30, 2002, to May 1, 2005. Affected trailers are built with two-axle steel tandem configurations.

The defect concerns the air ride suspension hanger weldment at the attachment point between the hanger and the subframe. If the suspension hanger weld fails, the suspension and axles can detach from the trailer frame and cause personal injury to persons outside the vehicle and could cause a crash without warning.

To remedy this defect, one must contact his Wilson dealer so they can inspect the area of concern, make necessary repairs, and install a support gusset to strengthen the weldment. The inspection, repair, and installation will be provided to you at no cost.

If you have any questions regarding this notice, please contact your Wilson dealer or Bob McLarty at Wilson Trailer Company, 1-800-798-2002.

Federal regulations require that any vehicle lessor receiving this recall notice must forward a copy of this notice to the lessee within ten days.

If you had this repair performed before you received this letter, you may be eligible to receive reimbursement for the cost of obtaining a pre-notification remedy of the problem associated with this recall. For more information contact Wilson Trailer Company, 1-800-798-2002.

If you do not presently own the above-listed trailer, please contact your Wilson dealer or

Linda Kollbaum at Wilson Trailer Company, 1-800-798-2002.

We regret any inconvenience that this action may cause you. However, we are concerned about your safety. If your dealer fails or is unable to remedy this defect without charge and within a reasonable time, you may submit a written complaint to the Administrator, National Highway Traffic Safety Administration, 400 Seventh Street SW, Washington, DC 20590, or call the toll-free Auto Safety Hotline at 1-888-327-4236 (TTY: 1-800-424-9153); or go to <http://www.safercar.gov>.

Sincerely,

Bob McLarty  
Technical Service & Claims Mgr.

Enclosures: Photograph of area of concern with and without the support gusset

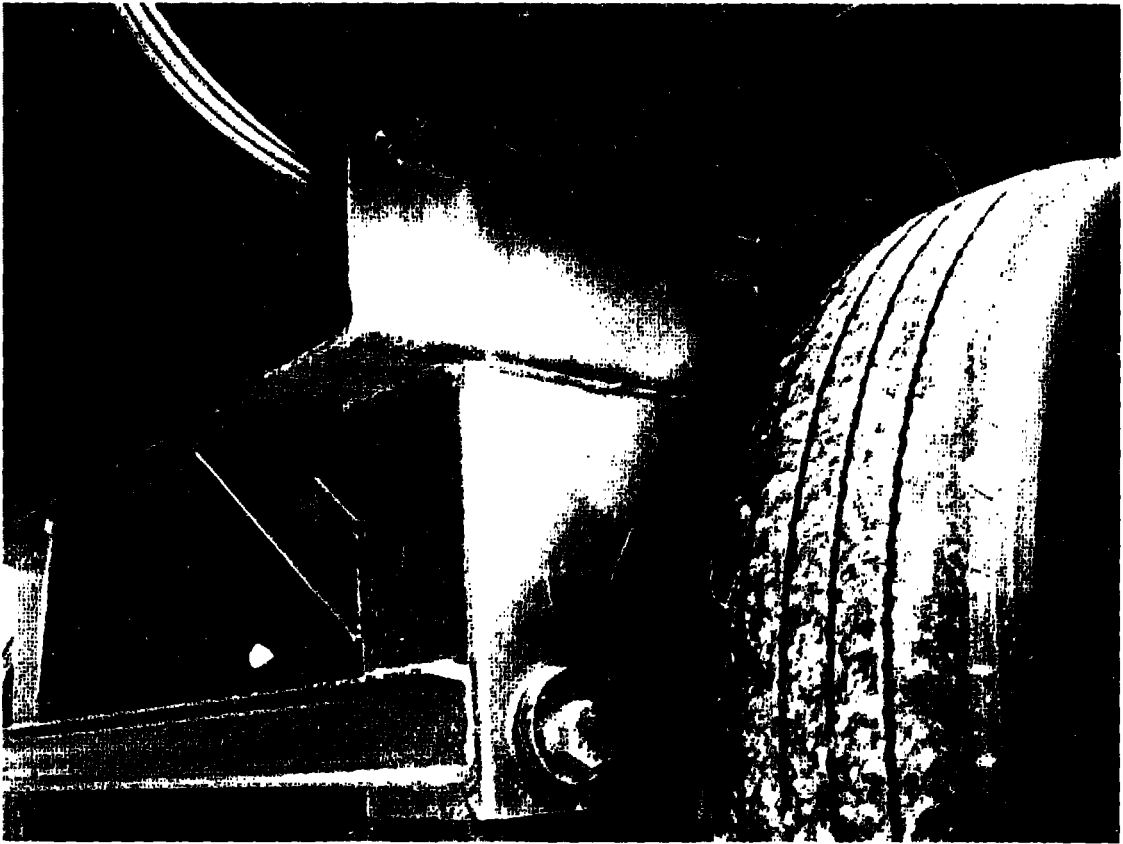

**Suspension Hanger without Support Gusset.**

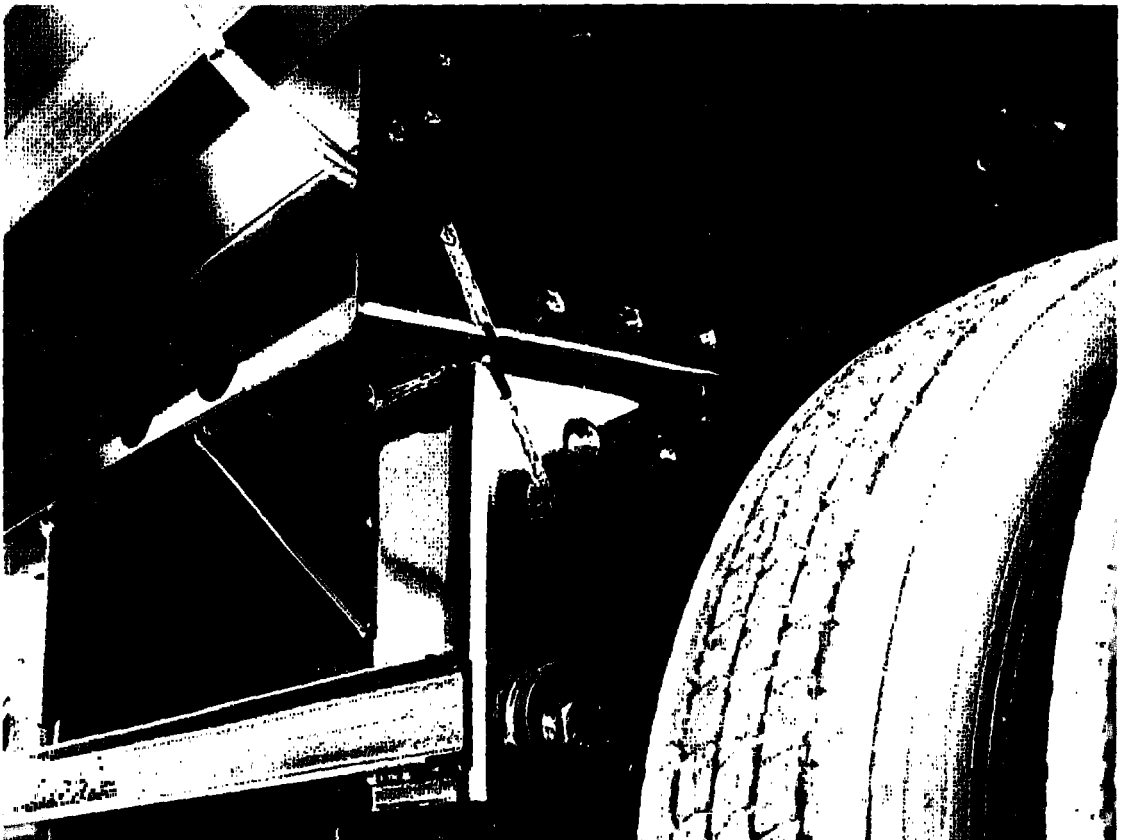

**Suspension Hanger with added Support Gusset.**

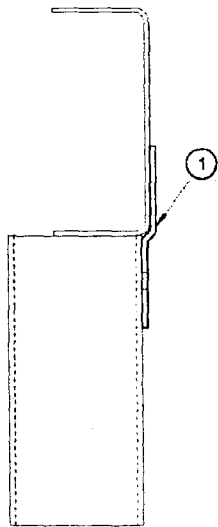
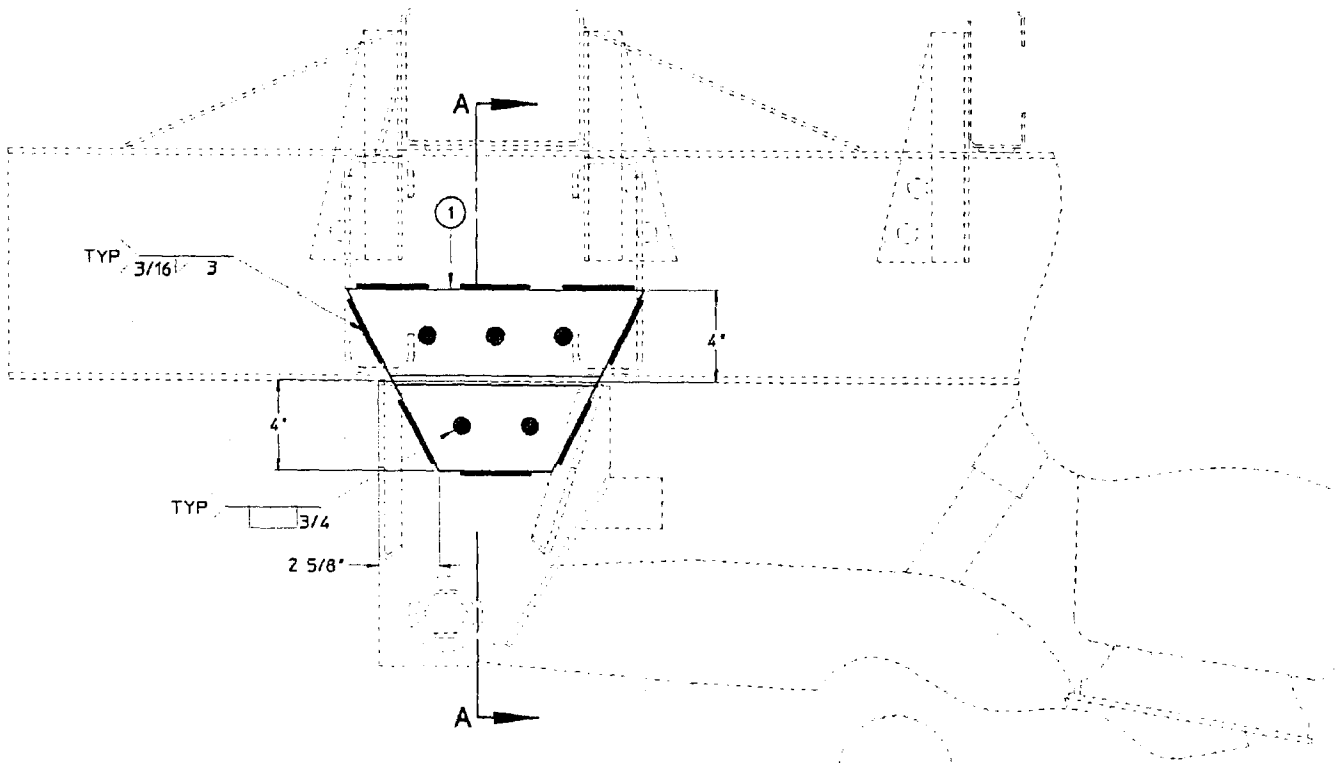

**SECTION A-A**  
SCALE - FULL

- REPAIR INSTRUCTIONS:
1. CHECK FOR CRACKED WELDS ON HANGER TO LONGMEMBER WELDMENT. IF CRACKED GRIND OUT WELDS AND REWELD.
  2. CENTER SUPPORT PLATE ON HANGER AND WELD
  3. END ALL FILLET WELDS 1/2" FROM ALL EDGES.

WILSON TRAILER CO. SIOUX CITY, IOWA										
DESCRIPTION										
ADDITIONAL HANGER GUSSET										
DRAWING BY XXX	DATE 1/24/54	101 SCALE	102 IN.	103 IN.	104 IN.	105 IN.	106 IN.	107 IN.	108 IN.	109 IN.
WEIGHT	PERFORMANCE XXX	SCALE	XXX	XXX	XXX	XXX	XXX	XXX	XXX	XXX
NEXT								ELY		PART NUMBER
XXX								XXX		B02968DU