



Timothy A. Blubaugh
Director
Government Technical Affairs

MAR 20 10 45
LETTER INVESTIGATION

Freightliner LLC
4747 N. Channel Avenue
Portland, OR 97217-7699
503.745.5219 Telephone
503.745.6800 Facsimile
TimothyBlubaugh@Freightliner.com

March 21, 2006

Dan Smith
Associate Administrator for Vehicle Safety
National Highway Traffic Safety Administration
400 Seventh Street, S.W.
Washington, D.C. 20590

Re: Defect Information Report (FL-467), NHTSA 05V-551

Mr. Smith:

In accordance with Part 573 of Title 49 of the Code of Federal Regulations, Freightliner LLC herewith submits supplemental defect information concerning the front axles on Business Class M2, Century, Columbia, Coronado; Sterling AT, LT, Acterra; FCC Motor Homes.

Please note that this recall is being conducted in two phases:

Phase I was mailed to customers March 15, 2006. The complete axle assembly will be replaced, addressing the higher capacity axles that are affected most by the axle defect.

Phase II will be conducted in mid-May, 2006, when parts are available for the higher volume 12,000 lb axles. These axles more closely meet the designed fatigue life. The axle beam and steering knuckles will be replaced.

Please contact me if you have any questions.

Sincerely yours,



Timothy Blubaugh

Cc: Michael Mason, CAL-OSHA
DOSH, Legal Unit
10th Floor
455 Golden Gate Avenue
San Francisco, CA 94102

Certified Mail Article Number:

Section 573.6 Non-Compliance Information Report
FL-467, Front Axle I-Beam; NHTSA no. 05V-551
Supplement No.: 3

March 21, 2006

(c) (1) Manufacturer: FREIGHTLINER LLC
P.O. BOX 3849
Portland, Oregon 97208
(503) 745-5219

(c) (3) Total number of vehicles potentially affected:
Phase 1: Axles with 13,300 and 14,700 GAWR: 89
Phase 2: Axles with 12,000 GAWR: Approximately 430

(c) (9) Estimated Owner Notification Date:
Phase 1: Customer notification by first class mail using Freightliner records was completed March 15, 2006. A copy of the customer letter and work instructions is attached.

Phase 2: Customer notification by first class mail using Freightliner records will be completed approximately May 26, 2006.

Subject: AAC Front Axle I-Beams

Models Affected: Specific Freightliner Business Class M2, Century, Columbia, and Coronado vehicles; Sterling A/L-Line and Acterra vehicles; and Freightliner Custom Chassis motorhome chassis manufactured between September 6, 2005, and October 20, 2005, with Axle Alliance Company front axles.

General Information

Freightliner LLC, on behalf of its Freightliner Trucks Division and its wholly owned subsidiaries, Freightliner Custom Chassis Corporation and Sterling Truck Corporation, has decided that a defect which relates to motor vehicle safety exists on the vehicles mentioned above.

There are approximately 100 vehicles involved in this campaign.

A forging defect in the top flange of the front axle I-beam may cause fatigue and fracture, resulting in a possible loss of control and vehicle crash without prior warning.

The front axle will be replaced.

Additional Repairs

Dealers must complete all outstanding recall and field service campaigns prior to the sale or delivery of a vehicle. A Dealer will be liable for any progressive damage that results from its failure to complete campaigns before sale or delivery of a vehicle.

Owners may be liable for any progressive damage that results from a failure to complete campaigns within a reasonable time after receiving notification.

Work Instructions

Please refer to the attached work instructions. Prior to performing the campaign, check the vehicle for a completion sticker (Form WAR260).

Replacement Parts

Replacement kits are now available and can be obtained by ordering the kit number(s) listed below from your facing Parts Distribution Center.

If our records show your dealership has ordered any vehicles involved in campaign number FL467A, a list of the customers and vehicle identification numbers will be available on AccessFreightliner.com. Please refer to this list when ordering parts for this recall.

Table 1 - Replacement Kits for FL467A

IMPORTANT: Not all axles require replacement. The replacement axles cannot be ordered for stock because they are specific to individual vehicles or to small groups of vehicles. When the inspection indicates that an axle must be replaced, order the appropriate kit with the vehicle serial number. Expedited freight may be included on your claim when necessary.

When an axle is replaced, the I-beam must be destroyed by cutting with a torch near the ID tag (if it is present). Take a digital photo of the cut beam that includes the ID tag and be prepared to provide it upon request. If the ID tag is not present, the photo should show that the I-beam has been destroyed.

When it is necessary as indicated in the Work Instructions to replace U-bolts, high nuts, and wheel seals, these may be included on the recall claim as miscellaneous parts.

Recall Campaign

March 2006
 FL467A
 NHTSA #05V-551

25-FL467-000 to 25-FL467-026

VINs Per Kit for Campaign Number FL467A	Kit Number	Description	For Axle Spec	Qty.	Suggested Wholesale*
V92540, U15751, W47509, W39684, V49361, V49360, V49359, W75854, W75853, V48632, V48631, V48630, V48629, V48633, V49544, V49543, V50382, W58143, W58142, V50386, V50385, V50384, V50383, W23308, W23309, U16613	25-FL467-000	Front Axle	C10-00014-005	1 ea	\$906.45 U.S. \$1,319.22 CAN
V59276, W18004, V28669, W53412, W53411, W53413, W53414, W53415, W53417, W53416, W41763	25-FL467-001	Front Axle	C10-00008-004	1 ea	\$1,000.14 U.S. \$1,455.56 CAN
W54096, W08566, W08567, W08568, W53902, W08569, W28675, W74658, W63729, W08570	25-FL467-002	Front Axle	C10-00014-001	1 ea	\$906.45 U.S. \$1,319.22 CAN
W27394, W27395, W27398, W27397, W27396, W27400, W27399, W27401	25-FL467-003	Front Axle	C10-00014-007	1 ea	\$906.45 U.S. \$1,319.22 CAN
W48996, W41756, W41755, V51533, V61957, V61959, V67290	25-FL467-004	Front Axle	C10-00008-009	1 ea	\$1,000.14 U.S. \$1,455.56 CAN
W42791, W48889, W48888, W48887, W41748, W19138, W24770	25-FL467-005	Front Axle	C10-00014-012	1 ea	\$906.45 U.S. \$1,319.22 CAN
W44104, V33308, V33307, V33306, V33309, W38586, W51912	25-FL467-006	Front Axle	C10-00014-015	1 ea	\$906.45 U.S. \$1,319.22 CAN
W72327, W72328, V59275, V28676, W25444, W52734, W53740	25-FL467-007	Front Axle	C10-00014-013	1 ea	\$906.45 U.S. \$1,319.22 CAN
W96457, W96458, W96459, W96460, W41846	25-FL467-008	Front Axle	C10-00014-009	1 ea	\$906.45 U.S. \$1,319.22 CAN
W74752, W74755, W74754, W58159, W58156	25-FL467-009	Front Axle	C10-00016-007	1 ea	\$1,000.14 U.S. \$1,455.56 CAN
W56640, W74709, W74753, W74710, W58151	25-FL467-010	Front Axle	C10-00016-000	1 ea	\$1,000.14 U.S. \$1,455.56 CAN
W48940, V49594, V58955, V58956	25-FL467-011	Front Axle	C10-00014-010	1 ea	\$906.45 U.S. \$1,319.22 CAN
W49694, W49692, V60870, V60869	25-FL467-012	Front Axle	C10-00008-008	1 ea	\$1,000.14 U.S. \$1,455.56 CAN
W75588, W51467, N72469, W51468	25-FL467-013	Front Axle	C10-00014-028	1 ea	\$906.45 U.S. \$1,319.22 CAN
W43522, W43525, W43524, W43523	25-FL467-014	Front Axle	C10-00008-015	1 ea	\$1,000.14 U.S. \$1,455.56 CAN
W52892, W52893, W52889	25-FL467-015	Front Axle	C10-00008-028	1 ea	\$1,000.14 U.S. \$1,455.56 CAN
W46891, W46890	25-FL467-016	Front Axle	C10-00014-008	1 ea	\$906.45 U.S. \$1,319.22 CAN
W25649	25-FL467-017	Front Axle	C10-00016-006	1 ea	\$1,000.14 U.S. \$1,455.56 CAN
W43935	25-FL467-018	Front Axle	C10-00008-005	1 ea	\$1,000.14 U.S. \$1,455.56 CAN
W54148	25-FL467-019	Front Axle	C10-00008-016	1 ea	\$1,000.14 U.S. \$1,455.56 CAN

Table 1, continued on the next page

Recall Campaign

March 2006
FL467A
NHTSA #05V-551

VINs Per Kit for Campaign Number FL467A	Kit Number	Description	For Axle Spec	Qty.	Suggested Wholesale*
U98859	25-FL467-020	Front Axle	C10-00014-034	1 ea	\$906.45 U.S. \$1,319.22 CAN
W56645	25-FL467-021	Front Axle	C10-00014-019	1 ea	\$906.45 U.S. \$1,319.22 CAN
W32601	25-FL467-022	Front Axle	C10-00014-002	1 ea	\$906.45 U.S. \$1,319.22 CAN
W39646	25-FL467-024	Front Axle	C10-00014-024	1 ea	\$906.45 U.S. \$1,319.22 CAN
U58678	25-FL467-025	Front Axle	C10-00014-021	1 ea	\$906.45 U.S. \$1,319.22 CAN
W51614	25-FL467-026	Front Axle	C10-00008-025	1 ea	\$1,000.14 U.S. \$1,455.56 CAN

* Please charge all Direct Warranty Customers the above-listed price for the kit, as they are authorized to perform their own Recalls.

Table 1, continued from the previous page

Removed Parts

Please follow Warranty Failed Parts Tracking shipping instructions for the disposition of all removed parts.

Labor Allowance

Table 2 - Labor Allowance

Campaign Number	Procedure	Time Allowed (hours)	SRT Code	Damage Code
FL467A	Inspect front axle	0.2	996-0670A	000-Inspected
FL467A	Inspect and remove/replace front axle; destroy removed axle	5.7	996-0670B	000-Modifiedx

Table 2

IMPORTANT: When the recall has been completed, locate the base completion label in the appropriate location on the vehicle, and attach the red completion sticker provided in the recall kit (Form WAR260). If the vehicle does not have a base completion label, clean a spot on the appropriate location of the vehicle and first attach the base completion label (Form WAR259). If a recall kit is not required or there is no completion sticker in the kit, write the recall number on a blank sticker and attach it to the base completion label.

Claims for Credit

You will be reimbursed for your parts, labor, and handling by submitting your claim through the Warranty system within 30 days of completing this campaign. Please reference the following information in QuickClaim®:

- Claim type is **Recall**.
- In the FTL Authorization field, enter the campaign number and appropriate condition code (**FL467A**).
- In the Primary Failed Part Number field, enter **25-FL467-000**.
- In the Parts field, enter the appropriate kit number(s) as shown in the Replacement Parts Table.

IMPORTANT: Not all axles require replacement. The replacement axles cannot be ordered for stock because they are specific to individual vehicles or to small groups of vehicles. When the inspection indicates that an axle must be replaced, order the appropriate kit with the vehicle serial number. Expedited freight may be included on your claim when necessary.

Recall Campaign

March 2006
FL467A
NHTSA #05V-551

When an axle is replaced, the I-beam must be destroyed by cutting with a torch near the ID tag (if it is present). Take a digital photo of the cut beam that includes the ID tag and be prepared to provide it upon request. If the ID tag is not present, the photo should show that the I-beam has been destroyed.

When it is necessary to replace U-bolts, high nuts, and wheel seals, these may be included on the recall claim as miscellaneous parts.

- In the Labor field, first enter the appropriate SRT from the Labor Allowance Table. For administrative time, enter SRT 939-0010A for 0.4 hours for RVs or 0.3 hours for all other vehicles.
- **Reimbursement for Prior Repairs.** When a customer asks about reimbursement, please do the following.
 - Accept the documentation of the previous repair.
 - Make a brief check of the customer's paperwork to see if the repair may be eligible for reimbursement. (See the "Copy of Owner Letter" section of this bulletin for reimbursement guidelines for this recall.)
 - Contact the Warranty Campaigns Department for a decision and authorization number.
 - Include the approved amount on your claim in sublet/outside purchases.
 - In the claim story, first note the authorization number and that the claim includes a reimbursement request.
 - Retain the documentation and provide it to Warranty Campaigns or Claims Processing if requested.
 - When your claim is paid, reimburse the customer the appropriate amount.

NOTE: ServicePro®/Service Advisor® must be viewed prior to performing the recall to ensure the vehicle is involved and the campaign has not been previously completed. Also, check for a completion sticker prior to beginning work.

Contact the Warranty Campaigns Department at (800) 547-0712, from 7:00 a.m. to 4:00 p.m. Pacific Time, Monday through Friday, Web inquiry at AccessFreightliner.com / Support / Submit an Inquiry, or the Customer Assistance Center at (800) 385-4357, after normal business hours, if you have any questions or need additional information.

To return excess kit inventory related to this campaign, U.S. dealers must submit a Parts Authorization Return (PAR) to the Memphis PDC. Canadian dealers must submit a PAR to their facing PDC. All kits must be in resalable condition. PAR requests must include the original purchase invoice number.

The letter notifying vehicle owners is included for your reference.

Please note that the National Traffic and Motor Vehicle Safety Act, as amended (Title 49, United States Code, Chapter 301), requires the owner's vehicle(s) be corrected within a reasonable time after parts are available to you. The Act states that failure to repair a vehicle within 60 days after tender for repair shall be prima facie evidence of an unreasonable time. However, circumstances of a particular situation may reduce the 60 day period. Failure to repair a vehicle within a reasonable time can result in either the obligation to (a) replace the vehicle with an identical or reasonably equivalent vehicle, without charge, or (b) refund the purchase price in full, less a reasonable allowance for depreciation. The Act further prohibits dealers from selling a vehicle unless all outstanding recalls are performed. Also, any lessor is required to send a copy of the recall notification to the lessee.

Finally, the Act states that a remedy need not be provided without charge if the vehicle was bought by the first purchaser more than ten (10) calendar years before notice is given.

Copy of Letter to Owner

Subject: AAC Front Axle I-Beams

This notice is sent to you in accordance with the requirements of the National Traffic and Motor Vehicle Safety Act. This notice is also sent in accordance with the Canadian Motor Vehicles Safety Act.

Freightliner LLC, on behalf of its Freightliner Trucks Division and its wholly owned subsidiaries, Freightliner Custom Chassis Corporation and Sterling Truck Corporation, has decided that a defect which relates to motor vehicle safety exists on specific Freightliner Business Class M2, Century, Columbia, and Coronado vehicles; Sterling A/L-Line and Acterra vehicles; and Freightliner Custom Chassis motorhome chassis manufactured between September 6, 2005, and October 20, 2005, with Axle Alliance Company front axles.

A forging defect in the top flange of certain front axle I-beams may cause fatigue and fracture, resulting in a possible loss of control and vehicle crash without prior warning.

The front axle will be inspected, and it will be replaced if necessary.

Repair kits are now available for authorized dealers to order. **IMPORTANT: Replacement parts are specific to individual vehicles, so they must be ordered after your vehicle is inspected by a dealership and it is determined that a replacement is needed.**

When you contact your dealer, refer to campaign number **FL467A**. Once kit(s) are received at the dealership, the work will take approximately 45 minutes for the inspection and seven to eight hours if the axle must be replaced and will be performed at no charge to you.

IMPORTANT: When the recall has been completed, please ensure that a label has been affixed to your vehicle referencing **FL467A**.

If you do not own the vehicle that corresponds to the identification number(s) which appears on the Recall Notification, please return the notification to the Warranty Campaigns Department with any information you can furnish that will assist us in locating the present owner. If you have leased this vehicle, please make sure this notification is immediately forwarded to the lessee.

If you are not able to have the defect remedied without charge and within a reasonable time, which is not longer than 60 days after you tender the vehicle for repair, please contact the Warranty Campaigns Department at (800) 547-0712, 7:00 a.m. to 4:00 p.m. Pacific Time, Monday through Friday, e-mail address WarrantyCampaigns@freightliner.com, or the Customer Assistance Center at (800) FTL-HELP or (800) STL-HELP, after normal business hours. You may also wish to submit a complaint to the Administrator, National Highway Traffic Safety Administration, 400 7th Street S.W., Washington, D.C. 20590; or call the Vehicle Safety Hotline at (888) 327-4236 (TTY: 800-424-9153); or to <http://www.safercar.gov>. If your vehicle is involved in the Canadian portion, you may wish to notify Transport Canada, ASFAD, Place de Ville Tower C, 330 Sparks Street, Ottawa, ON K1A 0N5, or phone (800) 333-0510.

We regret any inconvenience this action may cause but feel certain you understand our interest in motor vehicle safety.

WARRANTY CAMPAIGNS DEPARTMENT

Enclosure

Recall Campaign

March 2006
FL467A
NHTSA #05V-551

Reimbursement to Customers for Repairs Performed Prior to Recall

If you have already **paid** to have this recall condition corrected you may be eligible to receive reimbursement.

Requests for reimbursement may include parts and labor. Reimbursement may be limited to the amount the repair would have cost if completed by an authorized Freightliner LLC dealer. The following documentation must be presented to your dealer for consideration for reimbursement.

Please provide original or clear copies of all receipts, invoices, and repair orders that show:

- The name and address of the person who paid for the repair.
- The Vehicle Identification Number (VIN) of the vehicle that was repaired.
- What problem occurred, what repair was done, when the repair was done.
- Who repaired the vehicle.
- The total cost of the repair expense that is being claimed.
- Proof of payment for the repair (such as the front and back of a cancelled check or a credit card receipt).

Reimbursement will be made by check from your Freightliner LLC dealer.

Please speak with your Freightliner LLC authorized dealer concerning this matter.

Work Instructions

Subject: AAC Front Axle I-Beams

Models Affected: Specific Freightliner Business Class M2, Century, Columbia, and Coronado vehicles; Sterling A/L-Line and Acterra vehicles; and Freightliner Custom Chassis motorhome chassis manufactured between September 6, 2005, and October 20, 2005, with Axle Alliance Company front axles.

Front Axle Inspection and Replacement Procedures

IMPORTANT: Not all axles require replacement. The replacement axles cannot be ordered for stock because they are specific to individual vehicles or to small groups of vehicles. When the inspection indicates that an axle must be replaced, order the appropriate kit with the vehicle serial number. Expedited freight may be included on your claim when necessary.

When an axle is replaced, the I-beam must be destroyed by cutting with a torch near the ID tag (if it is present). Take a digital photo of the cut beam that includes the ID tag and be prepared to provide it upon request. If the ID tag is not present, the photo should show that the I-beam has been destroyed.

When it is necessary as indicated in the Work Instructions to replace U-bolts, high nuts, and wheel seals, these may be included on the recall claim as miscellaneous parts.

1. Check the base label (Form WAR259) for a completion sticker for FL467 indicating this work has been done. On straight trucks and tractors, the base label is usually located on the passenger-side door about 12 inches (30 cm) below the door latch; on motorhomes, the base label is usually located on the front wall under the dash. If a sticker for FL467 is present, nothing further needs to be done. If no sticker is present, go to the next step.
2. Park the vehicle on a level surface, shut down the engine, set the parking brake, and chock the rear tires.
3. Find the date code on the rear surface of the axle I-beam web, on the driver's side and near the U-bolt pad. See **Fig. 1**. Affected axle beams are those with the date code *05 244*.

If the date code is NOT *05 244*, no further work is necessary. Clean a spot on the base label (Form WAR259). Write the recall number, FL467, on a blank red completion sticker (Form WAR260) and attach it to the base label.

If the date code IS *05 244*, go to the next step.

4. Put the transmission in neutral.
5. At both sides of the vehicle, loosen all the front wheel nuts.

WARNING

Never work around or under a vehicle that is supported only by a jack. Always support the vehicle with safety stands. Jacks can slip, causing the vehicle to fall, which could result in serious injury or death.

6. Raise the front of the vehicle enough to take the load off the front suspension. Support the vehicle with safety stands under the frame rails.
7. Drain the air system.

Recall Campaign

March 2006
FL467A
NHTSA #05V-551

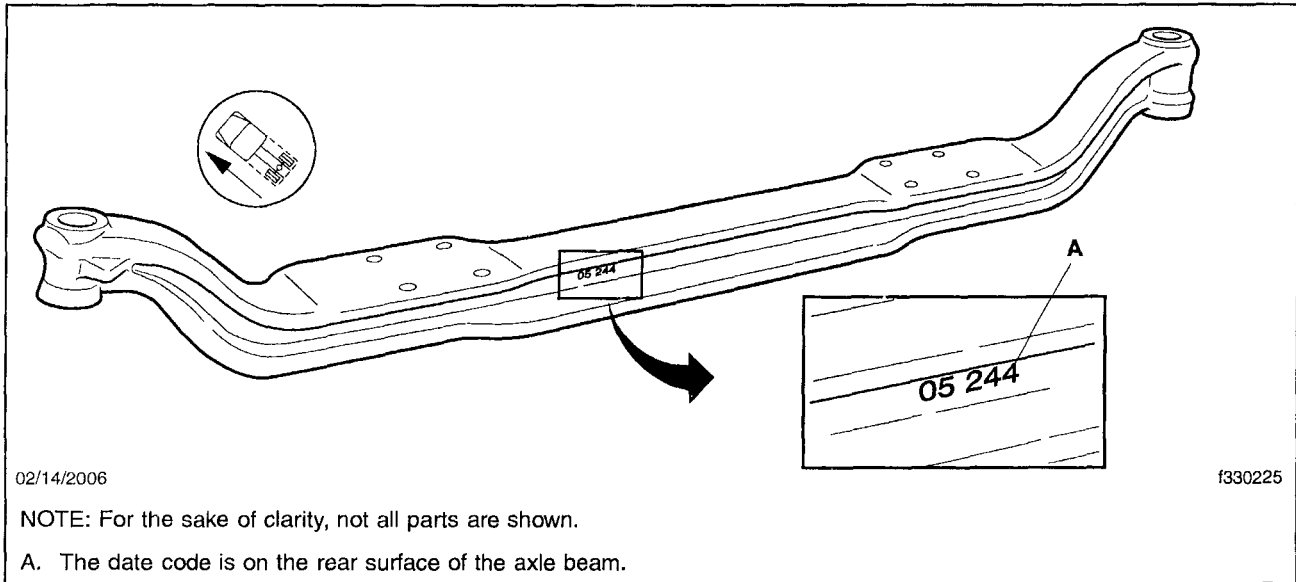

Fig. 1, Location of Date Code on Front-Axle Beam

8. Remove the front wheel and tire assemblies. For instructions, see **Group 40** of the applicable vehicle workshop manual.
9. Remove the brake drums. For instructions, see **Group 42** of the applicable vehicle workshop manual.
10. Remove the front hubs from the axle. For instructions, see **Group 33** of the applicable vehicle workshop manual.
11. Remove the brake shoes. For instructions, see **Group 42** of the applicable vehicle workshop manual.
12. Remove the ABS sensors and wiring from the brake anchor plates and secure the sensors and the wiring out of the way.
13. Remove the brake air chambers and the slack adjusters. For instructions, see **Group 42** of the applicable vehicle workshop manual.
14. Remove the brake anchor plates from the axle ends.
15. Disconnect the drag link from the axle steering arm.
16. If so equipped, disconnect the sway bar from the axle brackets.
17. Using a suitable jack, support the front axle.
18. Remove the U-bolt high nuts, or remove the nuts that hold the axle beam to the leaf springs and the air bag brackets, as applicable.
19. Remove the U-bolts, if applicable.
20. Remove the axle from the vehicle. The old axle beam must be cut into two pieces after removing it from the vehicle. Take a digital photo documenting the destruction of the removed beam.

IMPORTANT: When an axle is replaced, the I-beam must be destroyed by cutting with a torch near the ID tag (if it is present). Take a digital photo of the cut beam that includes the ID tag and be ready to provide it if requested. If the ID tag is not present, the photo should show that the I-beam has been destroyed.

21. With the new axle on a suitable jack, position it under the vehicle.

IMPORTANT: Suspension U-bolts and high nuts cannot be reused. They must be replaced with new parts.

22. For vehicles with front air suspension, raise the axle so that the holes in the axle beam line up with the bolts that hold the air bags to the leaf springs. Install the nuts and washers and tighten the nuts 220 lbf-ft (298 N·m).

For vehicles with a leaf-spring front suspension, install new U-bolts and high nuts. Tighten the high nuts in a diagonal pattern. See **Table 3** for torque values.

Torque Values for U-Bolt High Nuts			
Description	Size	IFI Grade	Torque: lbf-ft (N·m)
Axle U-Bolt High Nuts (Tighten in a diagonal pattern.)	7/8-14	C	Stage 1: Hand tighten Stage 2: 60 (81) Stage 3: 200 (271) Stage 4: 420-500 (571-680)
	1-14	C	Stage 1: Hand tighten Stage 2: 60 (81) Stage 3: 200 (271) Stage 4: 520-600 (707-816)

Table 3, Torque Values for U-Bolt High Nuts

23. If so equipped, connect the sway bar to the axle brackets. Tighten the sway bar fasteners 100 lbf-ft (136 N·m).
 24. Connect the drag link to the steering arm. For instructions, see **Group 46** of the applicable vehicle workshop manual.
 25. Install the brake anchor plates on the axle ends. For instructions, see **Group 42** of the applicable vehicle workshop manual.
 26. Install the brake air chambers and slack adjusters on the axle. For instructions, see **Group 42** of the applicable vehicle workshop manual.
 27. Install the ABS sensors.
 28. Install the brake shoes. For instructions, see **Group 42** of the applicable vehicle workshop manual.
 29. Install new oil seals, the existing hubs and wheel bearings, and adjust the wheel bearings. For instructions, see **Group 33** of the applicable vehicle workshop manual.
 30. Install the brake drums.
 31. Adjust the slack adjusters. For instructions, see **Group 42** of the applicable vehicle workshop manual.
 32. Install the tire and wheel assemblies. For instructions, see **Group 40** of the applicable vehicle workshop manual.
 33. Raise the vehicle, remove the safety stands, and lower the vehicle.
 34. Start the engine and build the air pressure.
 35. If equipped with a front air suspension, check that the suspension air bags are inflating correctly.
- IMPORTANT:** After replacing the front axle, it is necessary to check and adjust the front wheel toe-in.
36. Go to "Checking and Adjusting the Toe-In" in these Work Instructions.
 37. Remove the chocks from the rear tires.

Recall Campaign

March 2006
FL467A
NHTSA #05V-551

Checking and Adjusting the Toe-In

NOTE: See Fig. 2 for this procedure.

Using the alignment equipment manufacturer's operating instructions, measure the wheel toe-in. Compare the measurement with that shown in **Table 4**. If corrections are needed, go to the applicable (tie rod adjustment) step below.

IMPORTANT: For vehicle alignment to be accurate, the shop floor must be level in every direction. The turn plates for the front wheels must rotate freely without friction, and the alignment equipment must be calibrated every three months by a qualified technician from the equipment manufacturer. Freightliner dealers must have proof of this calibration history.

1. Apply the parking brakes, and chock the rear tires.
2. Raise the front of the vehicle until the tires clear the ground. Place safety stands under the axle. Make sure the stands will support the weight of the cab, axle, and frame.
3. Using spray paint or a piece of chalk, mark the entire center rib of each front tire.
4. Place a scribe or pointed instrument against the marked center rib of each tire, and turn the tires. The scribes must be held firmly in place so that a single straight line is scribed all the way around each tire.
5. Place a turn-plate or turntable under each tire. Remove the safety stands from under the axle, then lower the vehicle. Remove the lockpins from the gauges; make sure the tires are exactly straight ahead.

NOTE: If turn-plates or turntables are not available, lower the vehicle. Remove the chocks from the rear tires and release the parking brakes. Move the vehicle backward and then forward about six feet (2 meters).

6. Place the trammel bar at the rear of the front tires; locate the trammel pointers at spindle height, and adjust the pointers to line up with the scribe lines. Lock in place. Make sure that the scale is set on zero.
7. Place the trammel bar at the front of the tires as shown in **Fig. 3**. Adjust the scale end so that the pointers line up with the scribe lines. See **Fig. 4**.
8. Read the toe-in from the scale. Compare the toe-in with the value in **Table 4**. If corrections are needed, go to the next step.
9. Loosen the tie rod (cross tube) clamp nuts, and turn the tie rod as needed.

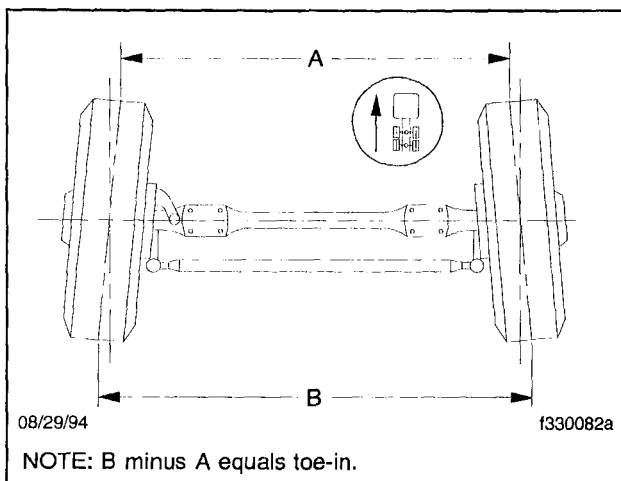

Fig. 2, Wheel Toe-In (Overhead View)

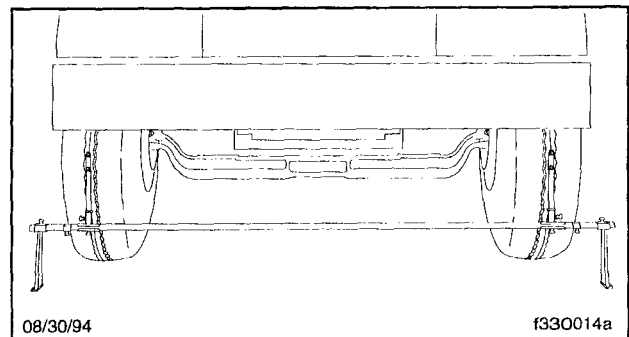

Fig. 3, Trammel Bar Positioning