

Sainte-Claire, November 23rd, 2005

Mr. Kenneth N. Weinstein,
Associate Administrator for Safety Assurance
National Highway Traffic Safety Administration
400, Seventh Street S.W.
Washington, DC 20590
USA

RECEIVED
2005-11-25
2005 DEC -7 A 9:52
OFFICE OF
DEFECTS INVESTIGATION

SUBJECT: SAFETY RECALL NOTIFICATION

Dear Mr. Weinstein,

As a coach manufacturer, Prévost Car Inc. advises you in accordance with your safety law, Part 573.6, that we have found a defect on some of our vehicles that does not meet the US Federal Motor Vehicle Standards and Regulations part 573.5.

The vehicles potentially affected by the defect are as follows:

MAKE: PRÉVOST

Model	VIN's	Manufacturing Dates
H3-41 & H3-45 Multiplex Coaches Model Year : 2004 - 2006	2PCH3349041014933, 2PCH3349941014963, 2PCH3349041014995, 2PCH3349X51010020, 2PCH3349451010109, 2PCH3349251010142 and From 2PCH3349951010168 up to 2PCH3349461010399 incl.	Between April 2004 and October 2005

The total number of vehicles potentially affected by the defect is estimated to be 117 in the U.S. and 51 in Canada, and the total number of the potentially affected vehicles in North America manufactured between April 2004 and October 2005 is 168.

The estimated percentage of the potentially affected vehicles that contain the defect is 100 % of the total manufactured quantity.

THE DEFECT MAY BE DESCRIBED AS FOLLOWS:

It has come to the attention of Prevost Car Inc. that on the previously mentioned vehicles, the lower wiper driving motor thermal protection may stop the motor if the motor has been in operation for a long time in second speed. This is due to the high amperage coming from the wiper motor and returning to the coach electrical system. The lower windshield wipers will not function in 1st speed, intermittently or in 2nd speed until the motor internal fuse has cooled down. For more information or help on how to perform this safety recall, contact your service manager or the nearest service centre.

THE EVENTS THAT WERE THE BASIS FOR THE DETERMINATION OF THE EXISTENCE OF A SAFETY DEFECT ARE:

For the last month, we have received 5 complaints on wiper motors that have stopped on both speeds. Investigations have been made and the conclusion was that new multiplex software B04 would completely cure the problem. B04 increases the multiplex amperage output to the wiper motor. This multiplex software was available in the network for customers around mid-October. A week later 2 new complaints came in with wipers quitting working with multiplex version B04. Quickly the decision has been made to come back to the original electrical wiper design prior multiplex coaches in order to make sure it won't happen again.

MEASURES TO BE TAKEN TO REPAIR THE DEFECT:

Safety recall no. 05-14 explains the complete procedure required.

As requested in paragraph 573.2 (8), three (3) copies of the letter that our customers (Defect Notification) will receive on that matter, and three (3) copies of Safety recall no. 05-14 are enclosed for your perusal.

If you require any information on that campaign, do not hesitate to contact us.

Truly yours,

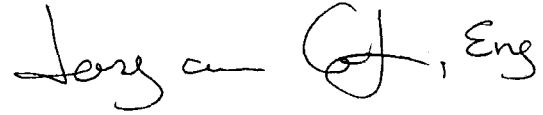
A handwritten signature in black ink, appearing to read "Josyane Côté, Eng". The signature is fluid and cursive, with the first name "Josyane" written in a larger, more prominent script than the last name "Côté". The initials "Eng" are written to the right of the name.

Josyane Côté, Eng.

Technical Publications Manager



PREVOST

ENREGISTRÉ-REGISTERED
ISO 9001 & ISO 14001

SAFETY RECALL

Sr05-14



DATE : November 2005	SECTION : 06
SUBJECT : NEW MULTIPLEX SOFTWARE PROGRAM AND INSTALLATION OF NEW WIPER HARNESS	

APPLICATION

Model	VIN
H3-41, H3-45 Coaches Model Year : 2004 - 2006	2PCH3349041014933, 2PCH3349941014963, 2PCH3349041014995, 2PCH3349X51010020, 2PCH3349451010109, 2PCH3349251010142 and From 2PCH3349951010168 up to 2PCH3349461010399 incl.
This Safety Recall does not necessarily apply to all the above-mentioned vehicles, some vehicles may have been modified before delivery. The owners of the vehicles affected by this recall will be advised by a letter indicating the Vehicle Identification Number (VIN) of each vehicle concerned.	

DESCRIPTION

It has come to the attention of Prevost Car Inc. that on the above-mentioned vehicles, the lower wiper driving motor thermal protection may stop the motor if the motor has been in operation for a long time in second speed. This is due to the high amperage coming from the wiper motor and returning to the coach electrical system. The lower windshield wipers will not function in 1st speed, intermittently or in 2nd speed until the motor internal fuse has cooled down. **To prevent this situation from happening, we strongly recommend that you make an appointment with your Prevost Car Service Center or that you contact your Regional Service Manager to have the new multiplex software program downloaded.**

MATERIAL

Part No.	Description	Qty
066734	Harness, Wiper retrofit	1
562934	Butt Splice	2
561918	Tubing, Heat Shrink	1

NOTE

Material can be obtained through regular channels.

PROCEDURE

⚠ WARNING ⚠

Park vehicle safely, apply parking brake, stop engine and set battery master switch(es) to the OFF position prior to working on the vehicle.

Before performing the installation of the wiper harness, contact your Prévost Car Service Center or your regional service manager in order to make an appointment for downloading the new multiplex software program P05.

⚠ CAUTION ⚠

To ensure proper operation, the new multiplex software program P05 MUST ABSOLUTELY be downloaded into the system before installing the new harness.

1. Remove dashboard cover and lower windshield wiper motor access panels (Refer to figure 1).
2. Disconnect connector C258 located at the base of steering column. Connect connector C258 of the new harness (066734) with cable coming from steering column multifunction lever.
3. Route cable end labeled "wipers" through inside of the dashboard and behind the driver's HVAC unit, towards the lower windshield wiper motor and the entrance door and wiper control panel; route the other end towards the front electrical and service compartment. Make sure the harness is properly secured using nylon ties by following the necessary precautions (Refer to figure 1).

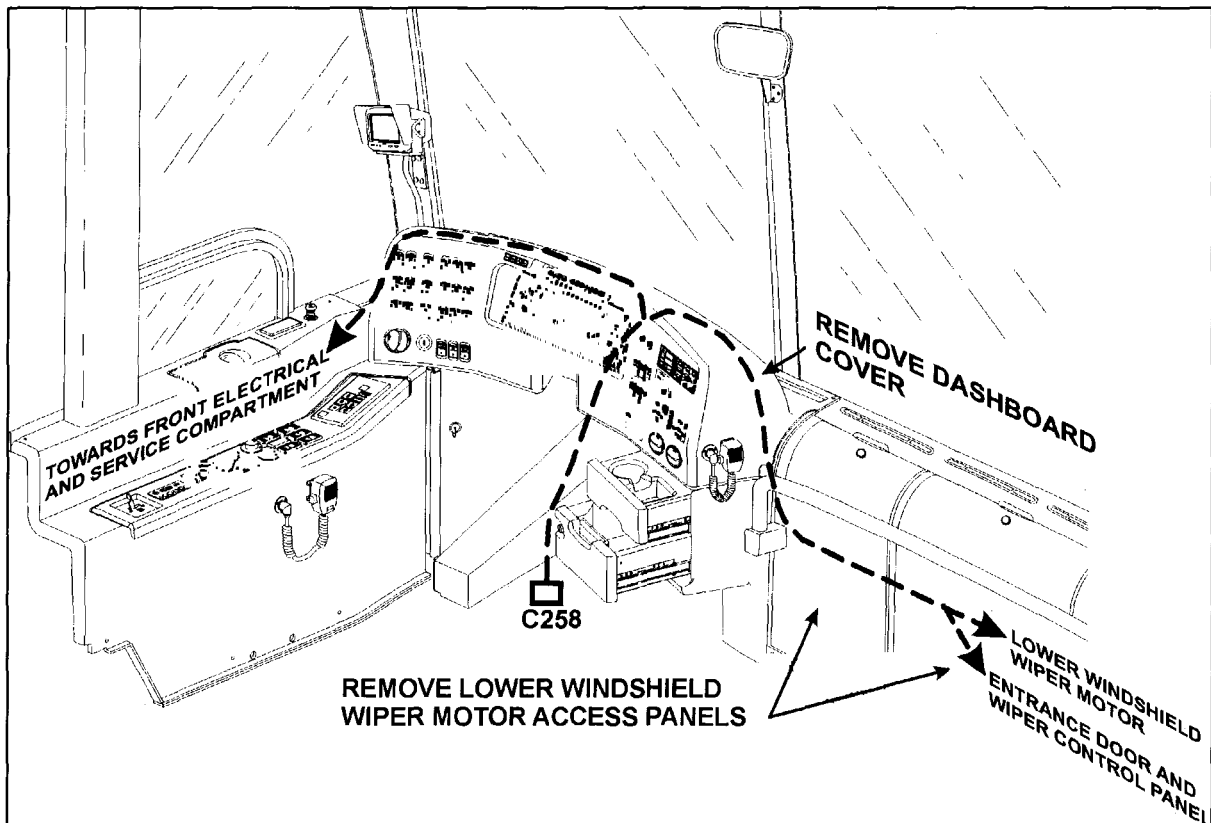

FIGURE 1: CABLE ROUTING

FRONT ELECTRICAL AND SERVICE COMPARTMENT

- Inside front electrical and service compartment, solder wire 24V17 of the new harness with wire 24V17 of RED connector VECF2-F;

NOTE

Terminal extractor tool for various multiplex module connector types may be found in the spare parts kit. Refer to TABLE 1 for the terminal removal procedure.

- Connect wire 64A of the new harness into connector J1, socket number 5 of module A43;
- Remove wire 64A from connector J1, socket number 20 of module A43. Cut heat shrink tubing up (561918) into four 3-inch long pieces and cover wire end with heat shrink tubing;
- Remove wire 59 from connector J1, socket number 8 of module A43 and cover wire end with heat shrink tubing, connect wire 59 of the new harness into connector J1, socket number 8 of module A43;
- Connect wire 53D of the new harness into connector J1, socket number 9 of module A44;
- Remove wire 53D from connector J1, socket number 9 of module A46 and cover wire end with heat shrink tubing;

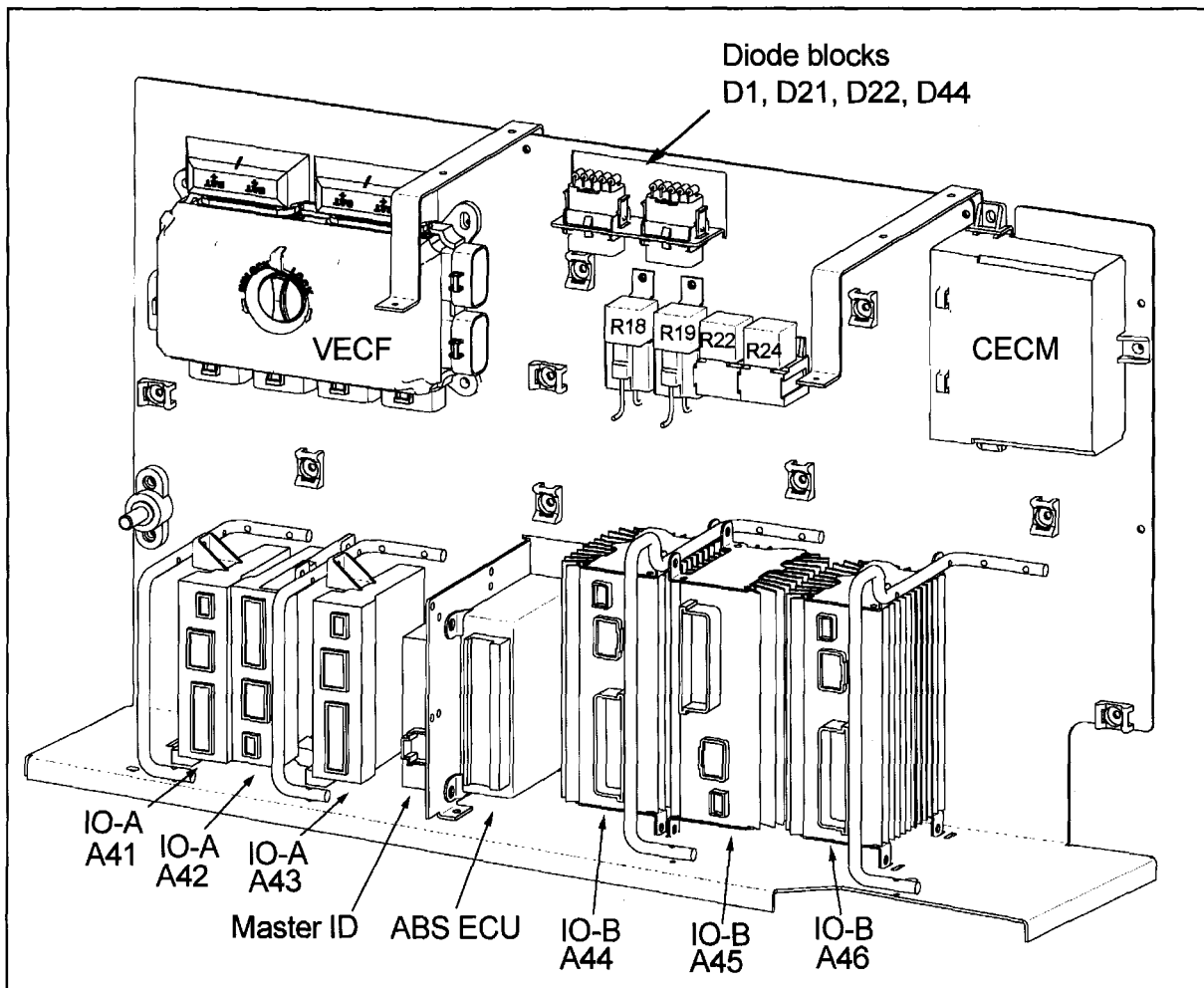
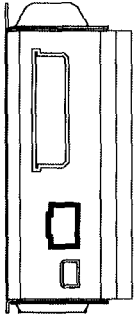
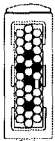
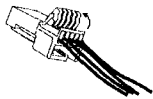
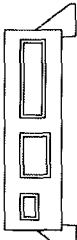

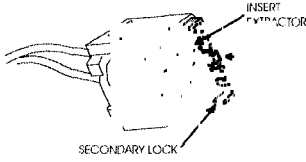
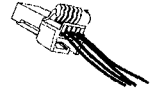
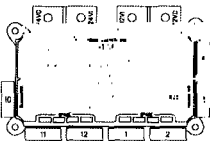
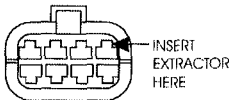

FIGURE 2: FRONT ELECTRICAL AND SERVICE COMPARTMENT

- Connect wire 53C of the new harness into connector J1, socket number 4 of module A42. It is possible that wire 92 be already inserted into this socket, if this is the case; connect wire 92 into connector J1, socket number 2 of module A42 before inserting wire 53C in place;
- Remove wire 53C from connector J1, socket number 8 of module A42;

TABLE 1		
Multiplex modules	Connector type	Terminal removal
 <p>IO-B</p>	 <p>AMP</p>	<p>EXTRACTOR/TOOL: Prevost #683594</p> <p>Insert the extractor on the front of the connector. Remove the terminal by disengaging the flexible lock tabs on the terminal. Gently remove the terminal from the connector by pulling on the wire.</p>
	 <p>green JAE</p>	<p>EXTRACTOR/TOOL: Prevost #683766</p> <p>Using a small flat blade screwdriver, open the hinged secondary lock. Insert the extractor on the front of the connector, over the terminal cavity. Remove the terminal by disengaging the flexible lock tab on the terminal. Gently remove the terminal from the connector by pulling on the wire.</p>
 <p>IO-A</p>	 <p>green, blue (CECM) JAE</p>	<p>EXTRACTOR/TOOL: Prevost #683766</p> <p>Using a small flat blade screwdriver, open both hinged secondary locks. Insert the extractor on the front of the connector, over the terminal cavity. Remove the terminal by disengaging the flexible lock tab on the terminal. Gently remove the terminal from the connector by pulling on the wire.</p>
	 <p>grey YAZAKI</p>	<p>EXTRACTOR/TOOL: Prevost #683766</p> <p>Using a small flat blade screwdriver, open the hinged secondary lock. Insert the extractor on the front of the connector, over the terminal cavity. Remove the terminal by disengaging the flexible lock tab on the terminal. Gently remove the terminal from the connector by pulling on the wire.</p>
	 <p>green JAE</p>	<p>EXTRACTOR/TOOL: Prevost #683766</p> <p>Using a small flat blade screwdriver, open the hinged secondary lock. Insert the extractor on the front of the connector, over the terminal cavity. Remove the terminal by disengaging the flexible lock tab on the terminal. Gently remove the terminal from the connector by pulling on the wire.</p>
 <p>VECF</p>	 <p>Orange Black Red Grey Brown Green Yellow BUSSMAN</p>	<p>EXTRACTOR/TOOL: Prevost #682256 (Packard 12094429)</p> <p>Remove the terminal by disengaging the flexible lock tab on the terminal. Gently remove the terminal from the connector by pulling on the wire.</p>

ENTRANCE DOOR AND WIPER CONTROL PANEL

- Remove wire 53B from connector J1, socket number 4 of module A47 and insert into butt splice (562934); insert wire 53B of the new harness into the other end of the butt splice, crimp and heat both ends.
- Remove wire 53G from socket number 30 of relay R23, and insert into butt splice (562934); insert wire 53 of the new harness into the other end of the butt splice, crimp and heat both ends.
- Insert wire 31B of the new harness into socket number 30 of relay R23.

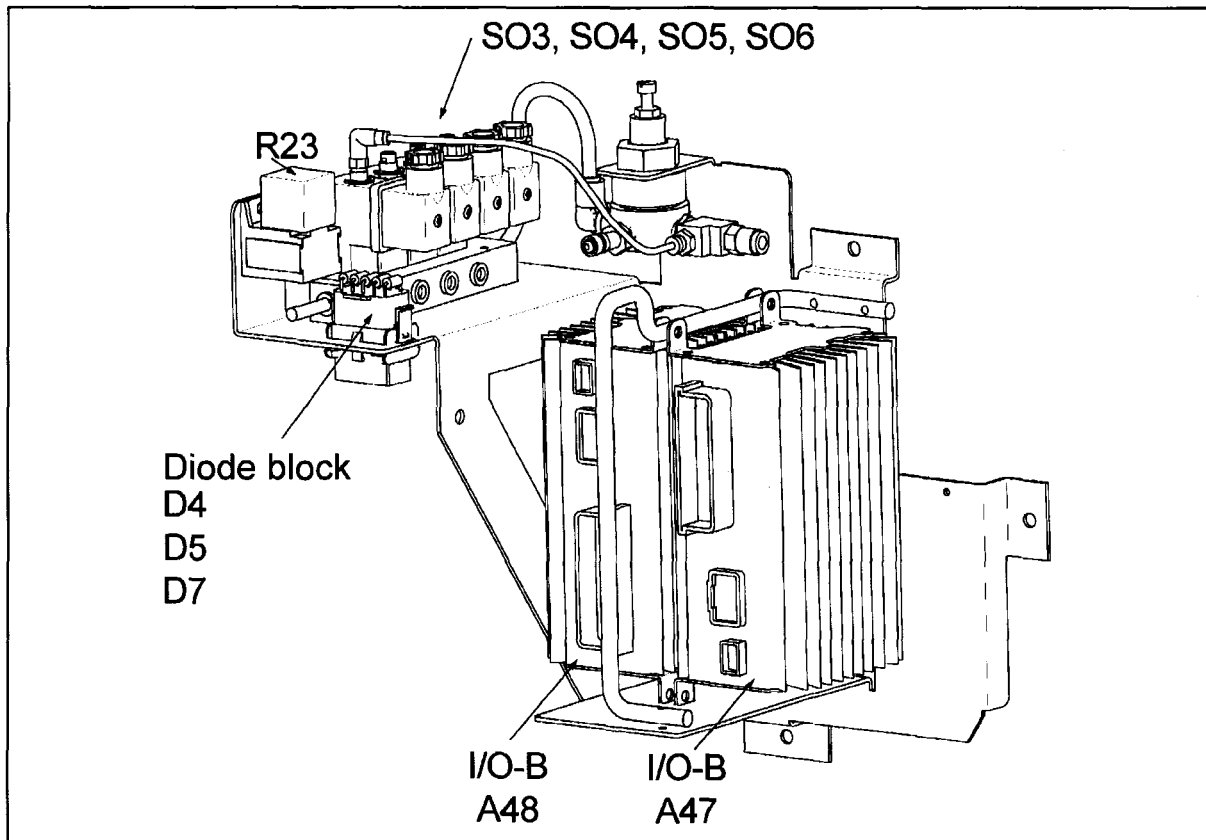

FIGURE 3: ENTRANCE DOOR AND WIPER CONTROL PANEL

**Check wiper operation in 1st speed, intermittently and in 2nd speed.
Also check courtesy blinkers operation.**

WARRANTY

This modification is covered by PrevoSt Car's normal warranty. We will reimburse you the parts and two hours (2.0) of labor upon receipt of a completed A.F.A. form on which you must specify as per "Safety Recall 05-14". **You also have to fill the "Safety Recall Certification Sheet" provided with this bulletin and return it with your A.F.A. form to be reimbursed.**

Parts disposition:

- Discard according to applicable environmental regulations (Municipal/State[Prov.]/ Federal)

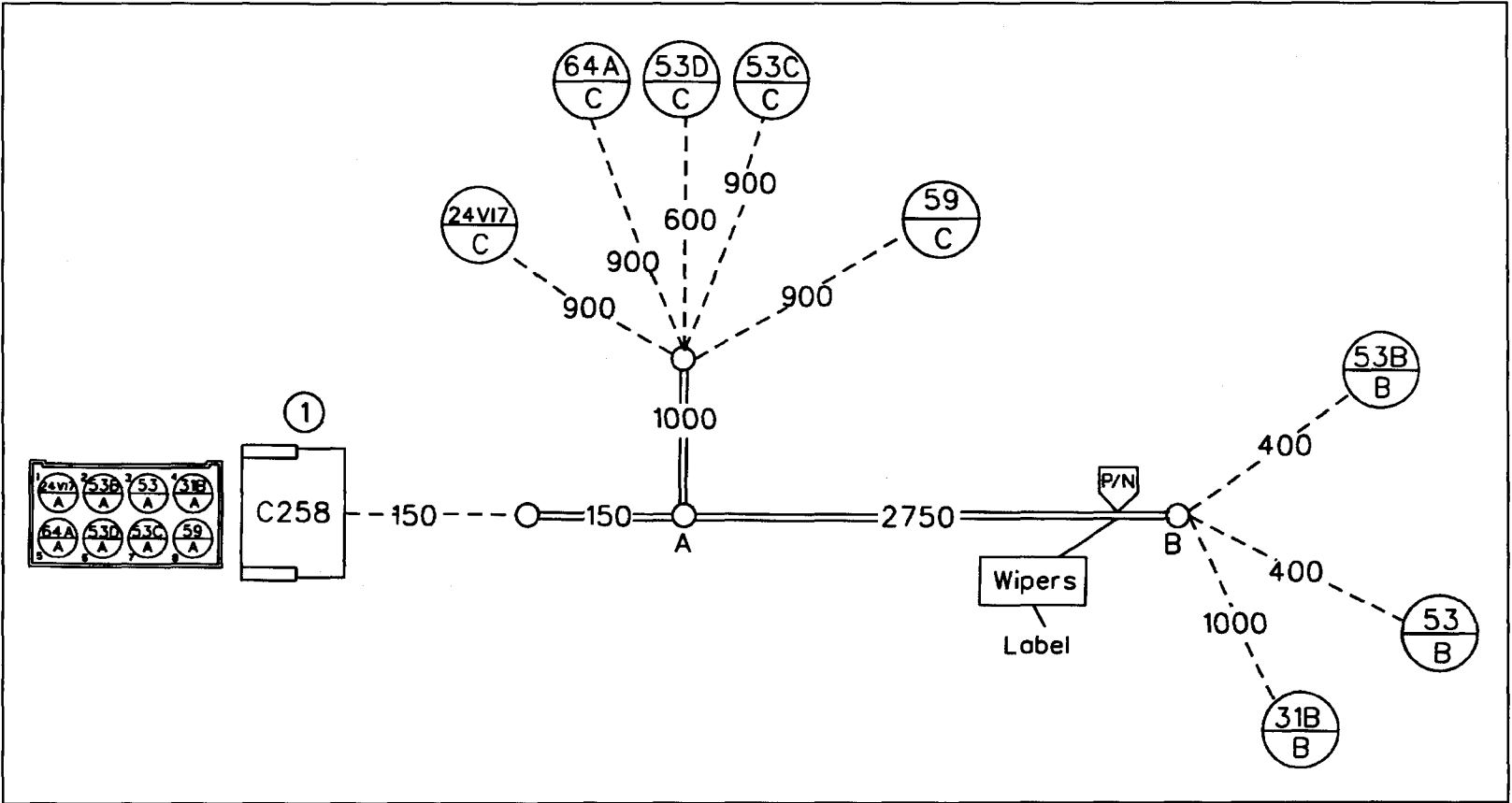
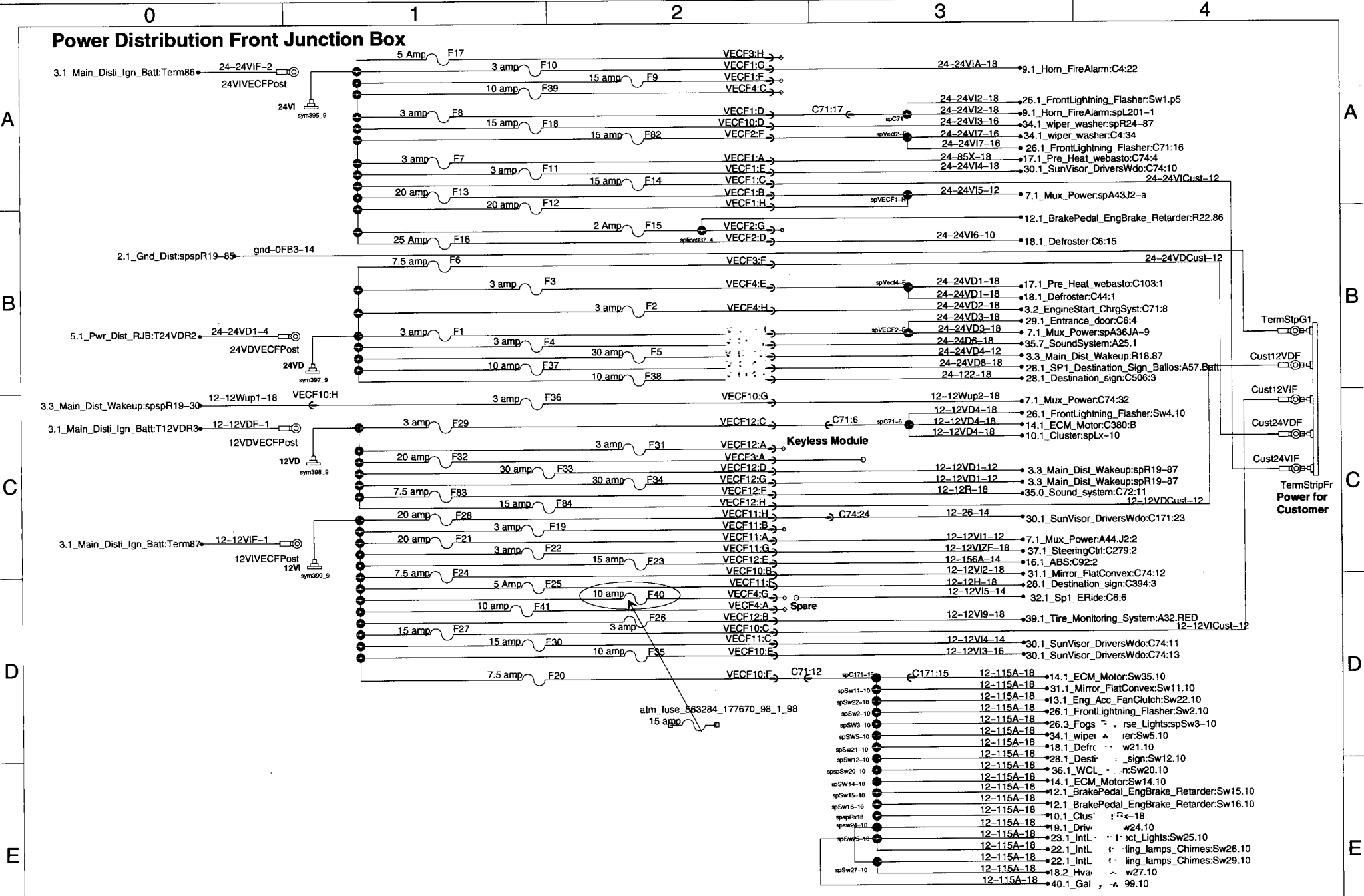
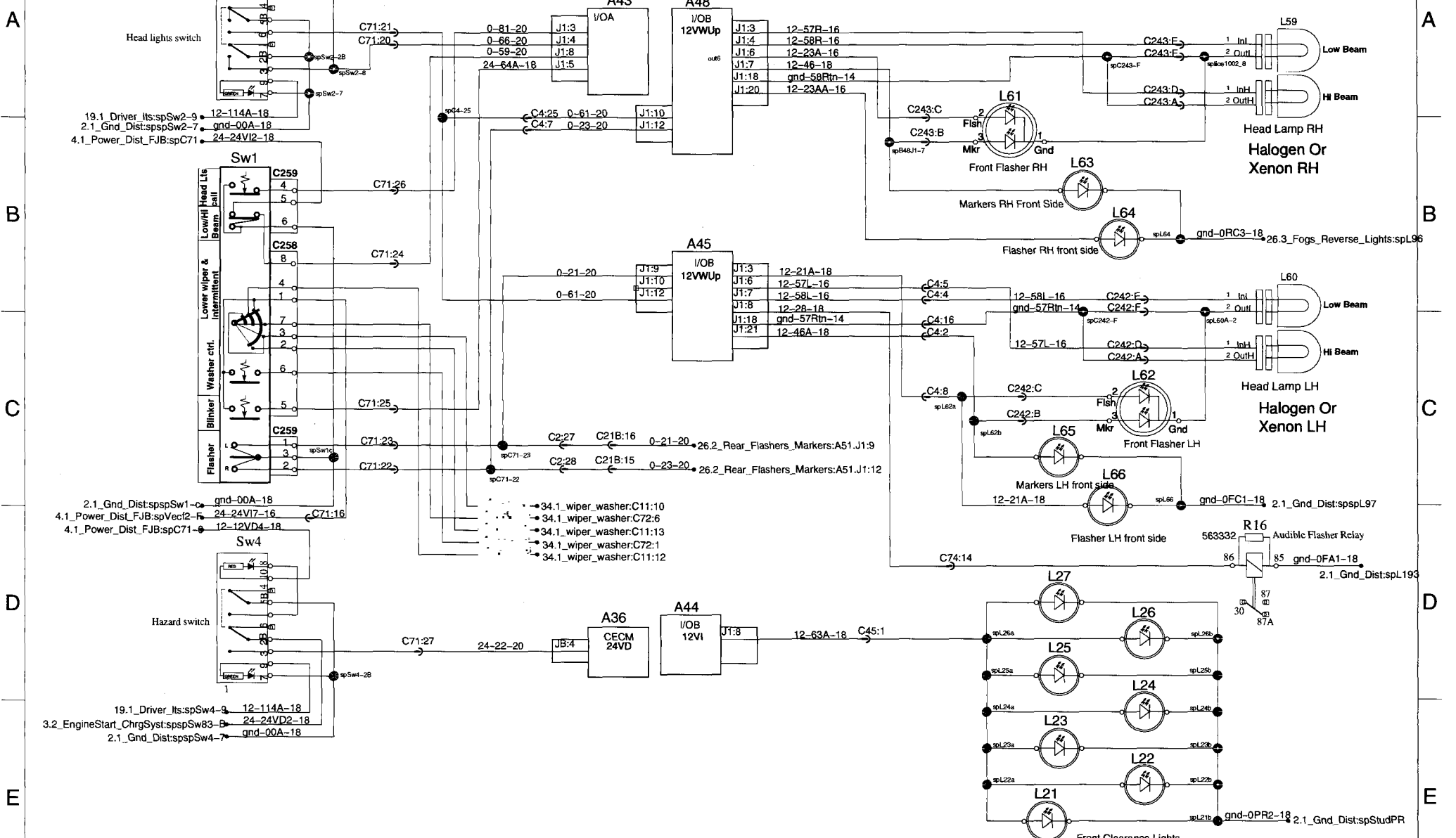

FIGURE 4: CABLE 066734

Power Distribution Front Junction Box



Front Flashers, Markers and Head Lights



Wiper and washer

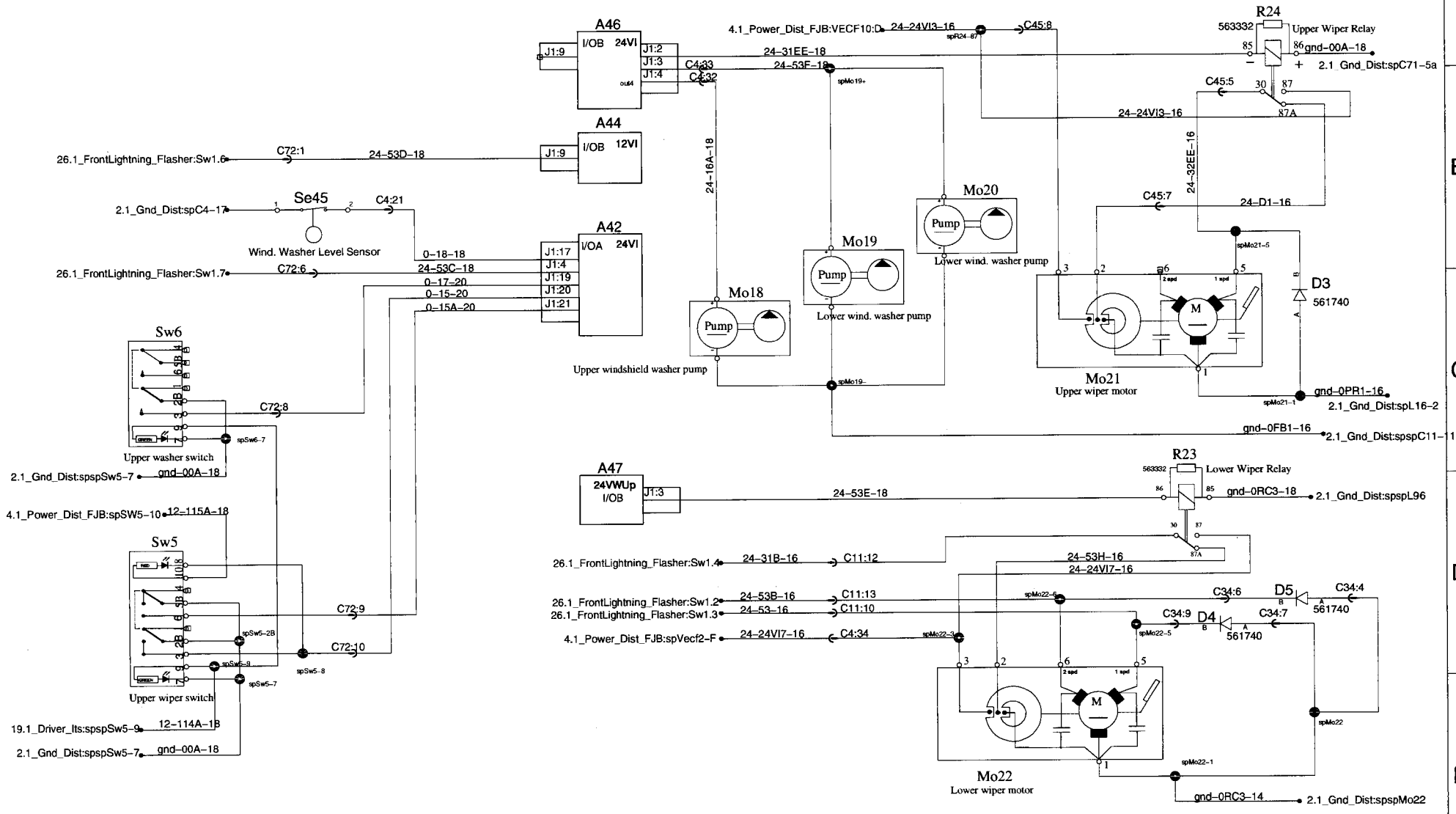



PREVOST

**Safety Recall
Certification Sheet
(Ref: Sr05-14)**

ENREGISTRÉ - REGISTERED
ISO 9001 & ISO 14001



SERIAL NUMBER: _____

PERFORMED BY		OWNER/OPERATOR	
We hereby certify that Safety Recall Instructions with regard to Safety Recall #05-14 have been performed.			
Name: _____		Name: _____	
Addr: _____		Addr: _____	
Phone: _____		Phone: _____	
Fax: _____		Fax: _____	
Signature : _____	_____	Signature : _____	_____
Date: _____	_____	Date: _____	_____

If the information mentioned above is incorrect or you are not the owner of this vehicle anymore, please fill this section and return to sender.

NEW OWNER: _____

BUSINESS: _____

ADDRESS (including County): _____

TELEPHONE: _____ **FAX:** _____

**Please return this completed document with your
A.F.A. form**

November 23rd, 2005

DEFECT NOTIFICATION

Dear Customer:

This notice is sent to you in accordance with the requirements of the National Traffic and Motor Vehicle Safety Act of U.S.A.

Prévost Car Inc. has decided that a defect which relates to motor vehicle safety exists in certain 2004-2006 H3-41 & H3-45 Multiplex Coaches. Prévost Car Inc., as coach manufacturer, has recently noticed that:

On the previously mentioned vehicles, the lower wiper driving motor thermal protection may stop the motor if the motor has been in operation for a long time in second speed. This is due to the high amperage coming from the wiper motor and returning to the coach electrical system. The lower windshield wipers will not function in 1st speed, intermittently or in 2nd speed until the motor internal fuse has cooled down. To prevent this situation from happening, we strongly recommend that you make an appointment with your Prévost Car Service Center or that you contact your Regional Service Manager to have the new multiplex software program downloaded and the procedure performed.

Model	Serial Numbers
H3-41 & H3-45 Multiplex Coaches Model Year : 2004 – 2006	2PCH33490 <u>4</u> 1014933, 2PCH33499 <u>4</u> 1014963, 2PCH33490 <u>4</u> 1014995, 2PCH3349X <u>5</u> 1010020, 2PCH33494 <u>5</u> 1010109, 2PCH33492 <u>5</u> 1010142 and From 2PCH33499 <u>5</u> 1010168 up to 2PCH33494 <u>6</u> 1010399 incl.

CORRECTIVE ACTIONS:

You must refer to the enclosed Safety Recall no. 05-14 and perform the stated procedure. Federal regulation requires that any vehicle lessor receiving this recall notice must forward a copy of this notice to the lessee within ten days.

REPORTING REQUIREMENT:

In order to verify and document the corrective action taken on your vehicle(s) pursuant to the requirements of the Federal Motor Vehicle Safety Regulations, we are enclosing a "**SAFETY RECALL CERTIFICATION**" sheet. When the vehicle(s) is (are) repaired, this (these) sheet(s) must be completed and returned to PRÉVOST CAR INC. head office.

LABOR & PARTS REIMBURSEMENT:

Prévost Car Inc. will reimburse you parts and labor incurred.

Federal laws require that you be informed of your right to notify the Department of Transportation if you are unable to have the defect remedied without charge. The address for this purpose is:

National Highway Traffic Safety Administration
Washington, DC 20590
USA

Auto Safety Hotline: 1-888-327-4236.

If any assistance is required, please contact your local distributor or the PRÉVOST CAR INC. after sales service department.