



PREVOST

ENREGISTRÉ - REGISTERED
ISO 9001 & ISO 14001

SAFETY RECALL

Sr05-14A



DATE : November 2005	SECTION : 06
SUBJECT : NEW MULTIPLEX SOFTWARE PROGRAM AND INSTALLATION OF NEW WIPER HARNESS	

REVISION : A

ADDITION OF SOME VEHICLES TO THE APPLICATION LIST

APPLICATION

Model	VIN
H3-41, H3-45 Coaches Model Year : 2004 - 2006	 2PCH3349041014933, 2PCH3349941014963, 2PCH3349041014995, 2PCH3349X51010020, 2PCH3349451010109, 2PCH3349251010142 and From 2PCH3349951010168 up to 2PCH3349061010416 incl.
<p>This Safety Recall does not necessarily apply to all the above-mentioned vehicles, some vehicles may have been modified before delivery. The owners of the vehicles affected by this recall will be advised by a letter indicating the Vehicle Identification Number (VIN) of each vehicle concerned.</p>	

DESCRIPTION

It has come to the attention of Prevost Car Inc. that on the above-mentioned vehicles, the lower wiper driving motor thermal protection may stop the motor if the motor has been in operation for a long time in second speed. This is due to the high amperage coming from the wiper motor and returning to the coach electrical system. The lower windshield wipers will not function in 1st speed, intermittently or in 2nd speed until the motor internal fuse has cooled down. **To prevent this situation from happening, we strongly recommend that you make an appointment with your Prévost Car Service Center or that you contact your Regional Service Manager to have the new multiplex software program downloaded.**

MATERIAL

Part No.	Description	Qty
066734	Harness, Wiper retrofit	1
562935	Butt Splice	2
561918	Tubing, Heat Shrink	1

NOTE

Material can be obtained through regular channels.

PROCEDURE

⚠ WARNING ⚠

Park vehicle safely, apply parking brake, stop engine and set battery master switch(es) to the OFF position prior to working on the vehicle.

Before performing the installation of the wiper harness, contact your Prévost Car Service Center or your regional service manager in order to make an appointment for downloading the new multiplex software program P05.

⚠ CAUTION ⚠

To ensure proper operation, the new multiplex software program P05 **MUST ABSOLUTELY** be downloaded into the system before installing the new harness.

Beware: When downloading a new MUX program you might loose fuel pedal. Perform the following instruction before downloading the program.

If your coach does not have a WCL:

-Disconnect wire 953A located between pin 22 of connector C397 and connector J1, socket number 2 of module A53.

If your coach has a WCL + ZF transmission:

-Disconnect wire 953A located between pin 22 of connector C397 and connector J1, socket number 2 of module A53.

-Add a wire between connector J1, socket number 2 of module A53 and pin G2 of ZMTECH module.

-Download last ZF program version if not done yet???

If your coach has a WCL sliding door + Allison transmission:

-Disconnect wire 953A located between pin 22 of connector C397 and connector J1, socket number 2 of module A53.

-Signal Transmission inhibit should be already wired between connector J1, socket number 2 of module A50 and A1CV-11 #155.

1. Remove dashboard cover and lower windshield wiper motor access panels (Refer to figure 1).

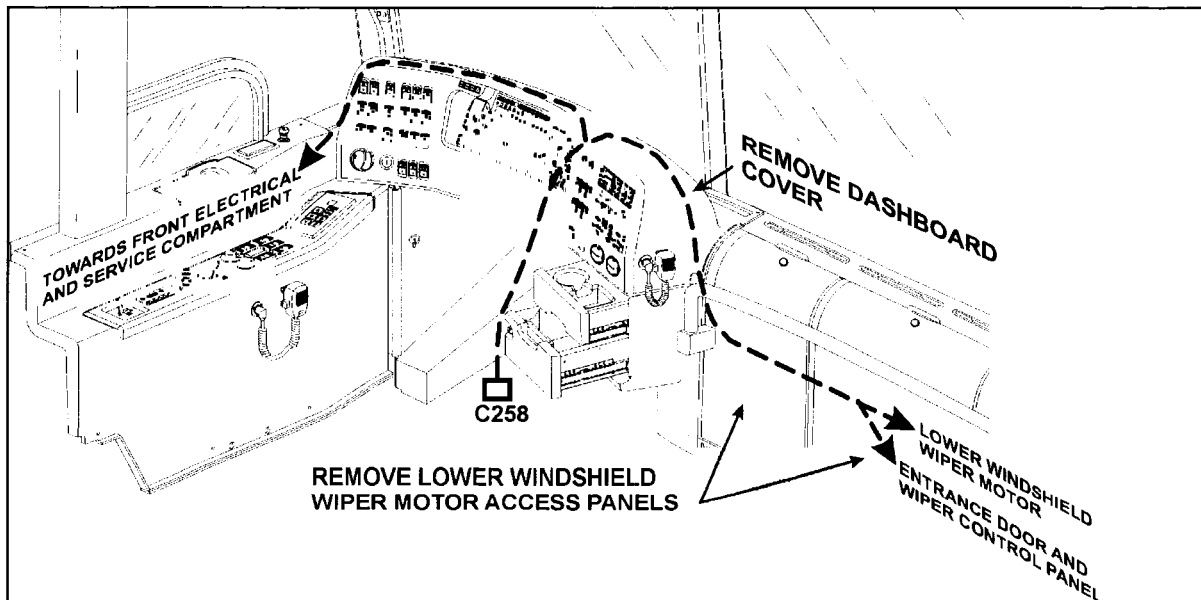

FIGURE 1: CABLE ROUTING

2. Disconnect connector C258 located at the base of steering column. Connect connector C258 of the new harness (066734) with cable coming from steering column multifunction lever.
3. Route cable end labeled "wipers" through inside of the dashboard and behind the driver's HVAC unit, towards the lower windshield wiper motor and the entrance door and wiper control panel; route the other end towards the front electrical and service compartment. Make sure the harness is properly secured using nylon ties by following the necessary precautions (Refer to figure 1).

FRONT ELECTRICAL AND SERVICE COMPARTMENT

- Cut heat shrink tubing up (561918) into five 2.5-inch long pieces;
- Inside front electrical and service compartment, solder wire 24V17 of the new harness with wire 24V17 of RED connector VECF2-F; cover solder with heat shrink tubing;

NOTE

Terminal extractor tool for various multiplex module connector types may be found in the spare parts kit. Refer to TABLE 1 for the terminal removal procedure.

- Connect wire 64A of the new harness into connector J1, socket number 5 of module A43;
- Remove wire 64A from connector J1, socket number 20 of module A43 then cover wire end with heat shrink tubing;

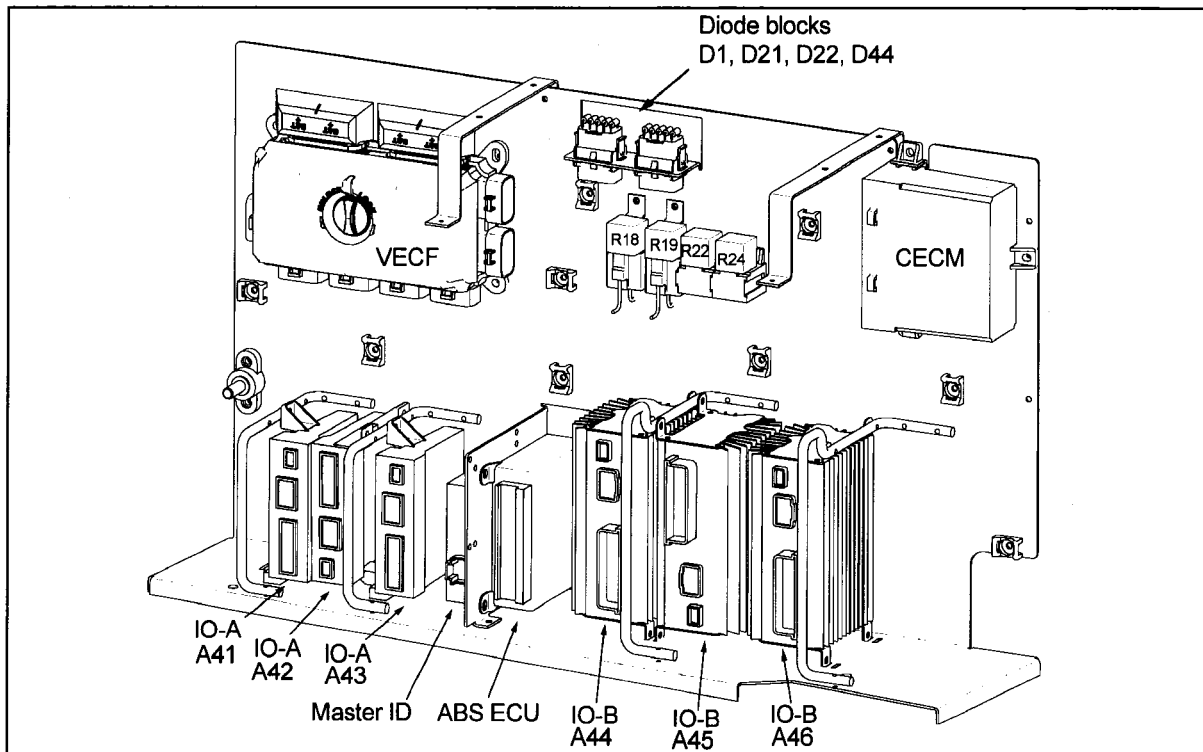
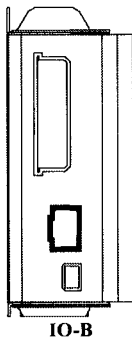
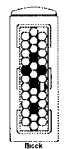

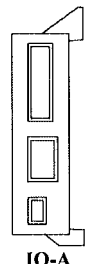

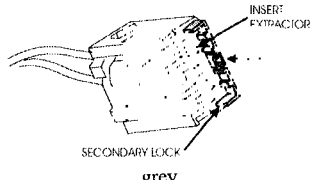

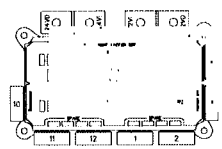
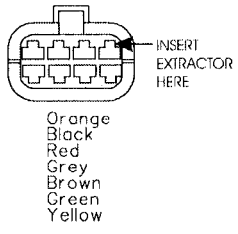

FIGURE 2: FRONT ELECTRICAL AND SERVICE COMPARTMENT

- Remove wire 59 from connector J1, socket number 8 of module A43 and cover wire end with heat shrink tubing, connect wire 59 of the new harness into connector J1, socket number 8 of module A43;
- Connect wire 53D of the new harness into connector J1, socket number 9 of module A44;
- Remove wire 53D from connector J1, socket number 9 of module A46 and cover wire end with heat shrink tubing;

- Connect wire 53C of the new harness into connector J1, socket number 4 of module A42. It is possible that wire 92 be already inserted into this socket, if this is the case; connect wire 92 into connector J1, socket number 2 of module A42 before inserting wire 53C in place;
- Remove wire 53C from connector J1, socket number 8 of module A42 then cover wire end with heat shrink tubing.

TABLE 1		
Multiplex modules	Connector type	Terminal removal
 <p style="text-align: center;">IO-B</p>	 <p style="text-align: center;">AMP</p>	<p>EXTRACTOR/TOOL: Prevost #683594</p> <p>Insert the extractor on the front of the connector. Remove the terminal by disengaging the flexible lock tabs on the terminal. Gently remove the terminal from the connector by pulling on the wire.</p>
	 <p style="text-align: center;">green JAE</p>	<p>EXTRACTOR/TOOL: Prevost #683766</p> <p>Using a small flat blade screwdriver, open the hinged secondary lock. Insert the extractor on the front of the connector, over the terminal cavity. Remove the terminal by disengaging the flexible lock tab on the terminal. Gently remove the terminal from the connector by pulling on the wire.</p>
 <p style="text-align: center;">IO-A</p>	 <p style="text-align: center;">green, blue (CECM) JAE</p>	<p>EXTRACTOR/TOOL: Prevost #683766</p> <p>Using a small flat blade screwdriver, open both hinged secondary locks. Insert the extractor on the front of the connector, over the terminal cavity. Remove the terminal by disengaging the flexible lock tab on the terminal. Gently remove the terminal from the connector by pulling on the wire.</p>
	 <p style="text-align: center;">SECONDARY LOCK grey YAZAKI</p>	<p>EXTRACTOR/TOOL: Prevost #683766</p> <p>Using a small flat blade screwdriver, open the hinged secondary lock. Insert the extractor on the front of the connector, over the terminal cavity. Remove the terminal by disengaging the flexible lock tab on the terminal. Gently remove the terminal from the connector by pulling on the wire.</p>
	 <p style="text-align: center;">green JAE</p>	<p>EXTRACTOR/TOOL: Prevost #683766</p> <p>Using a small flat blade screwdriver, open the hinged secondary lock. Insert the extractor on the front of the connector, over the terminal cavity. Remove the terminal by disengaging the flexible lock tab on the terminal. Gently remove the terminal from the connector by pulling on the wire.</p>
 <p style="text-align: center;">VECF</p>	 <p style="text-align: center;"> Orange Black Red Grey Brown Green Yellow BUSSMAN </p>	<p>EXTRACTOR/TOOL: Prevost #682256 (Packard 12094429)</p> <p>Remove the terminal by disengaging the flexible lock tab on the terminal. Gently remove the terminal from the connector by pulling on the wire.</p>

ENTRANCE DOOR AND WIPER CONTROL PANEL

- Remove wire 53B from connector J1, socket number 4 of module A47 and insert into butt splice (562935); insert wire 53B of the new harness into the other end of the butt splice, crimp and heat both ends.
- Remove wire 53G from socket number 30 of relay R23, and insert into butt splice (562935); insert wire 53 of the new harness into the other end of the butt splice, crimp and heat both ends.
- Insert wire 31B of the new harness into socket number 30 of relay R23.

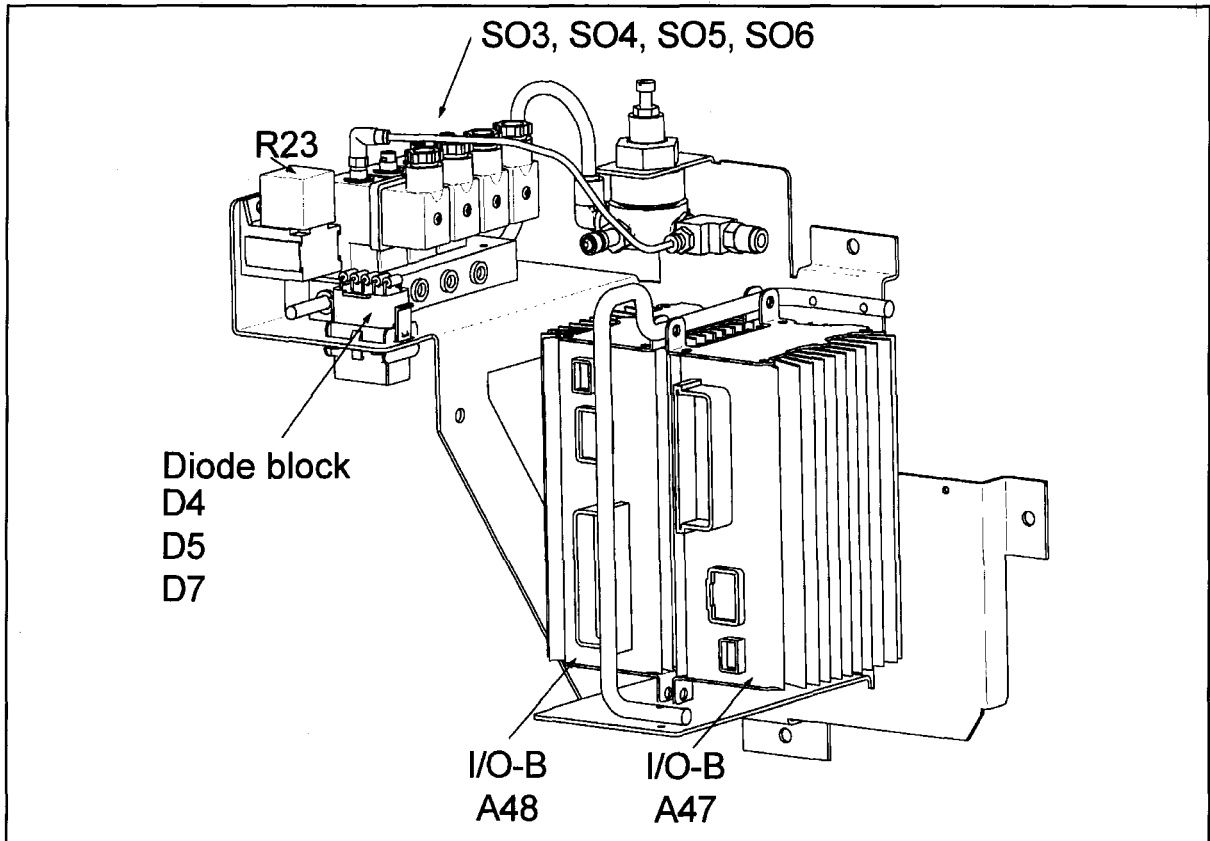

FIGURE 3: ENTRANCE DOOR AND WIPER CONTROL PANEL

Check wiper operation in 1st speed, intermittently and in 2nd speed.

Also check courtesy blinkers operation.

WARRANTY

This modification is covered by Prevost Car's normal warranty. We will reimburse you the parts and two hours (2.0) of labor upon receipt of a completed A.F.A. form on which you must specify as per "Safety Recall 05-14". You also have to fill the "Safety Recall Certification Sheet" provided with this bulletin and return it with your A.F.A. form to be reimbursed.

Parts disposition:

- Discard according to applicable environmental regulations (Municipal/State[Prov.]/ Federal)

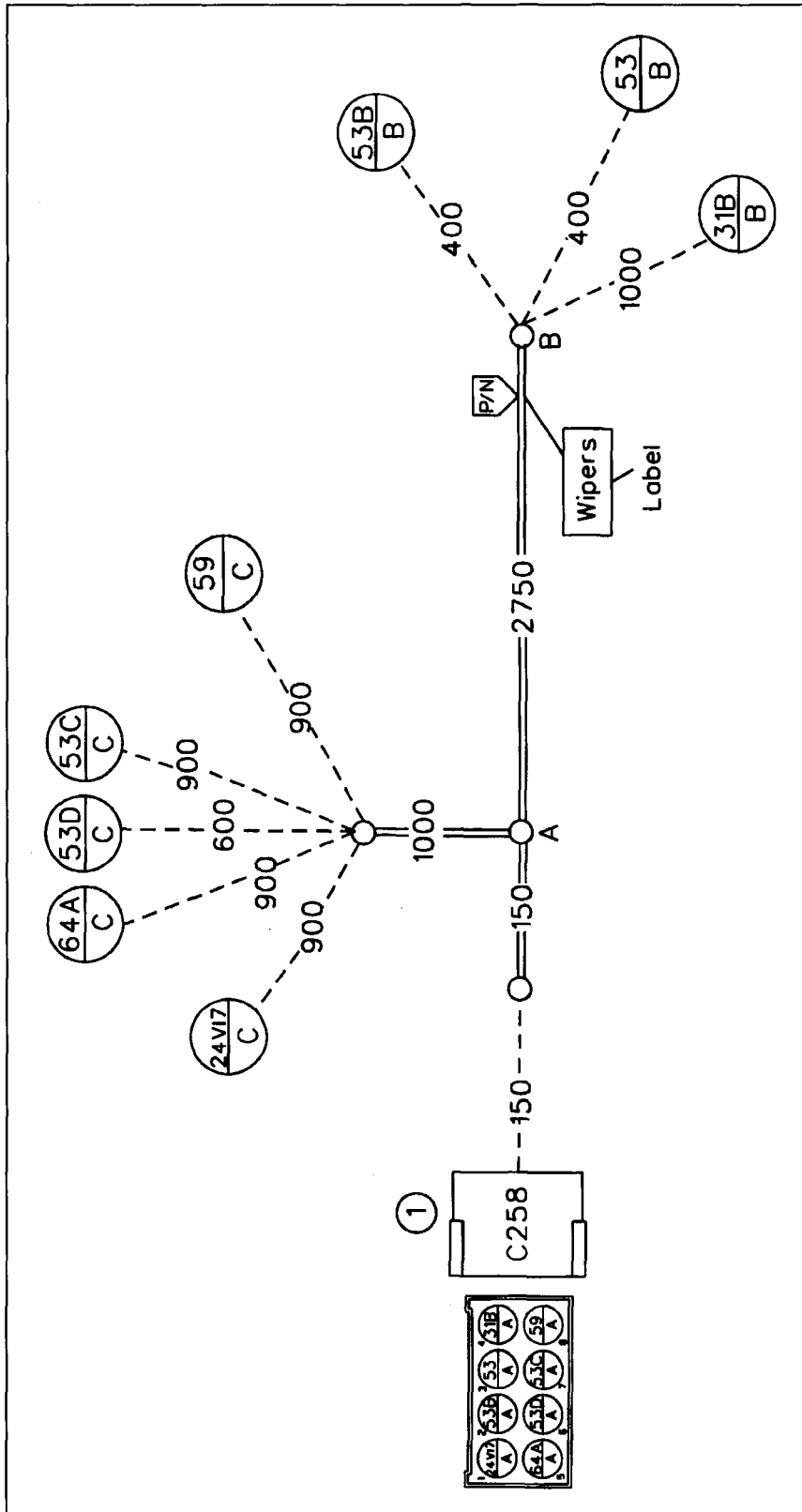
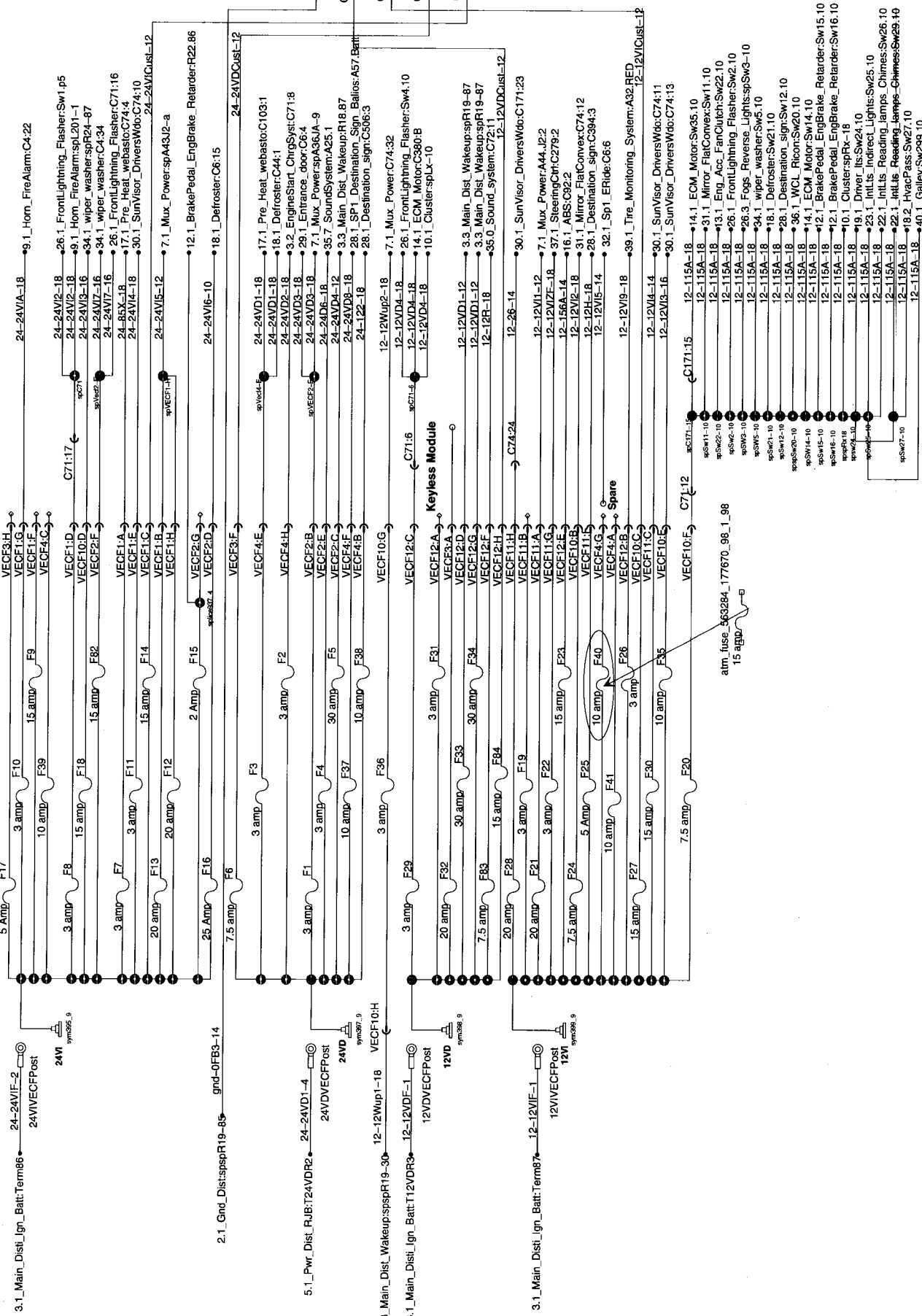
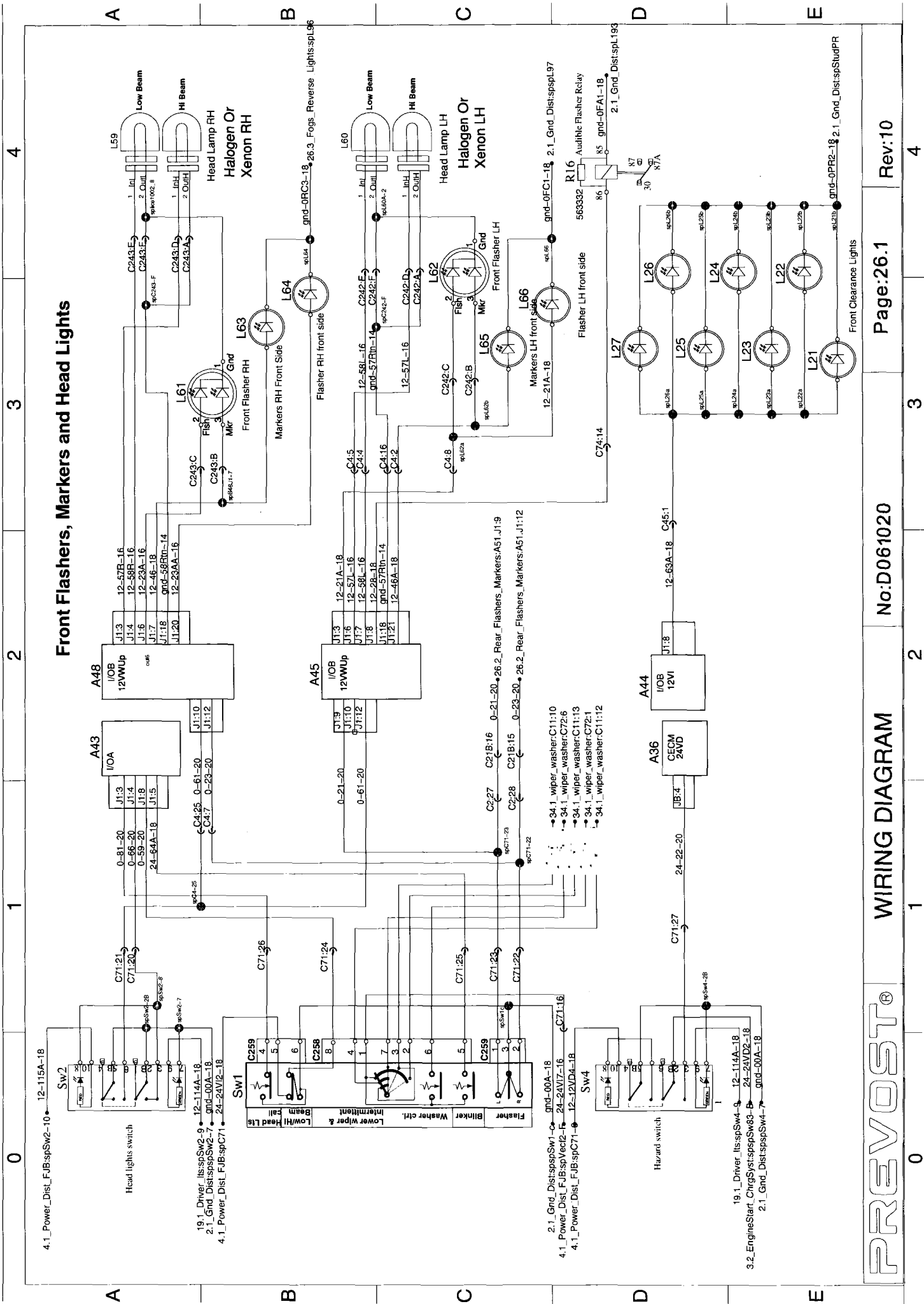

FIGURE 4: CABLE 066734

Power Distribution Front Junction Box



Front Flashers, Markers and Head Lights





PREVOST

ENREGISTRÉ - REGISTERED
ISO 9001 & ISO 14001



Safety Recall Certification Sheet (Ref: Sr05-14A)

SERIAL NUMBER: _____

PERFORMED BY		OWNER/OPERATOR	
We hereby certify that Safety Recall Instructions with regard to Safety Recall #05-14A have been performed.			
Name: _____		Name: _____	
Addr: _____		Addr: _____	
Phone: _____		Phone: _____	
Fax: _____		Fax: _____	
Signature :	_____	Signature :	_____
Date:	_____	Date:	_____

If the information mentioned above is incorrect or you are not the owner of this vehicle anymore, please fill this section and return to sender.

NEW OWNER: _____

BUSINESS: _____

ADDRESS (including County): _____

TELEPHONE: _____ **FAX:** _____

**Please return this completed document with your
A.F.A. form**