



# RECALL CAMPAIGN BULLETIN

Reference:

NTB05-100

Date:

November 1, 2005

## VOLUNTARY RECALL CAMPAIGN 2005 XTERRA TOW HITCH

**CAMPAIGN I.D. # / NHTSA #:** PB009 / 05V-458

**APPLIED VEHICLE:** 2005 Xterra (N50)

**APPLIED VINS:** Vehicles built within: 5N1AN08\*\*5C600000 - 658527

**NOTE:** The above listed VIN's will not be in Service Com. We are not able to identify which vehicles are equipped with a tow hitch, so Service Com will not be used for this Campaign.

### INTRODUCTION

Nissan has determined that some 2005 model year Nissan Xterra vehicles may have a defect which relates to motor vehicle safety. There is a possibility that the Nissan accessory tow hitch may not have been manufactured properly by the supplier, Valley Industries. Using the tow hitch could result in the trailer separating from the vehicle. To prevent this condition from occurring, Nissan is conducting a Voluntary Safety Recall Campaign to replace the hitch with a new one free of charge.

Valley Industries has marketed a small number of hitches under their own label which they have determined are also defective. As an accommodation to Valley, Xterra owners have been advised that Valley hitches are also subject to recall. Valley has authorized Nissan to have Nissan dealers replace hitches using the procedures outlined in this bulletin.

### IDENTIFICATION NUMBER

Nissan has assigned identification number PB009 to this campaign. This number must appear on all communications and documentation of any nature dealing with this Campaign.

### NUMBER OF VEHICLES POTENTIALLY AFFECTED

Approximately 12,500 hitch assemblies installed on 2005 model year Xterra vehicles.

### DEALER RESPONSIBILITY

It is the retailer's responsibility to inspect the Tow Hitch label for either a Nissan P/N 999T5-KR100 or a Valley Industries P/N 2112-00-385 on each vehicle falling within the range of this voluntary safety recall which for any reason enters the service department. Other tow hitches are not involved in this campaign. This includes vehicles purchased from private parties or presented by transient (tourist) owners and vehicles in a dealer's inventory. **Federal law requires that new vehicles in dealer inventory which are the subject of a safety recall must be corrected prior to delivery under a sale or lease. Failure to do so can result in civil penalties by the National Highway Traffic Safety Administration.** While federal law applies only to new vehicles, Nissan strongly encourages dealers to correct any used vehicles in their inventory before they are retailed.

## SERVICE PROCEDURE

This bulletin contains two Service Procedures:

### Procedure A - Vehicles Equipped With Either a Nissan or Valley Industries Tow Hitch:

- Affected Tow Hitches have a label with either Nissan P/N 999T5-KR100 or Valley Industries P/N 2112-00-385 printed on it. See Figure 1.

**NOTE:** If the vehicle is equipped with a tow hitch other than a Nissan or Valley Industries tow hitch, no repair is necessary. Do not replace the tow hitch.

- This procedure shows how to remove the existing Tow Hitch and replace it with a new one.

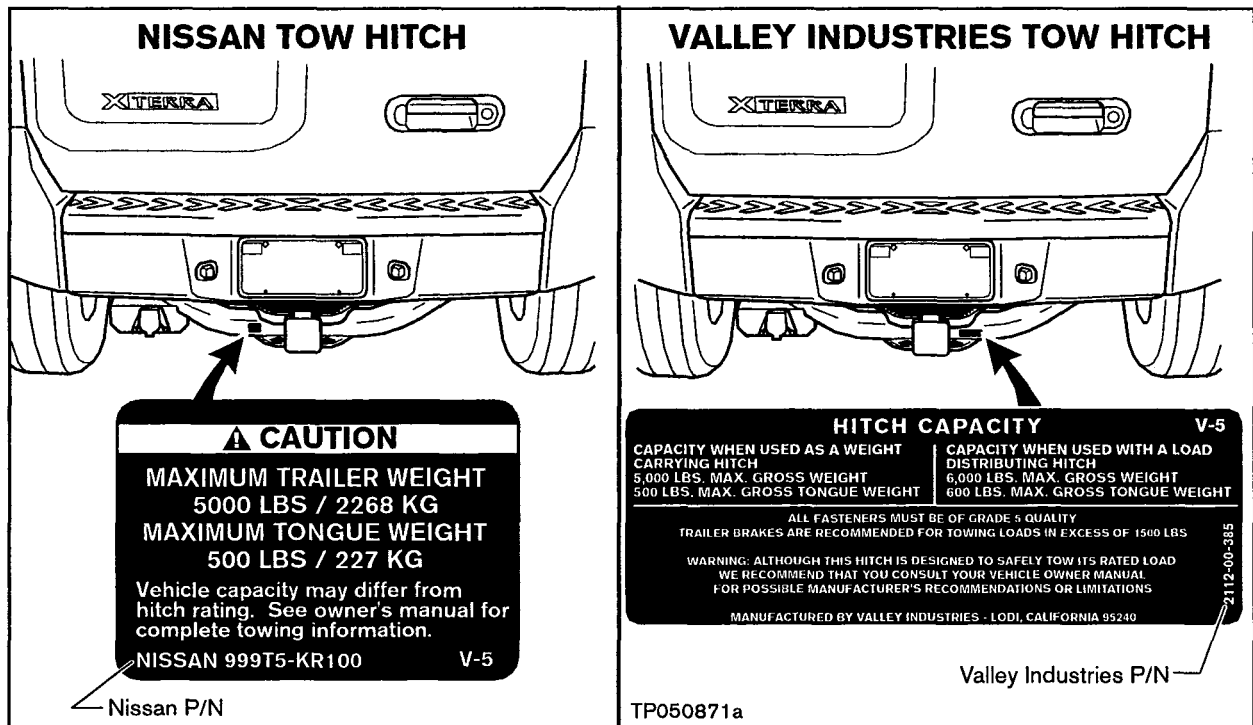

Figure 1

### Procedure B - Vehicles With Previously Removed Nissan Tow Hitch (Limited Number of Vehicles):

- On a limited number of vehicles, the selling dealer removed the Nissan tow hitch prior to first retail sale.
- This procedure shows how to install a new Tow Hitch on vehicles where the original Tow Hitch was removed prior to retail sale of the vehicle.
- In this procedure you'll need to re-unite the Tow Hitch Kit and Trailer Lights Wire Harness (stored at the dealer) to the applicable vehicle.

**NOTE:** If the vehicle was retailed by another dealership, you'll need to retrieve the Tow Hitch Kit and Trailer Lights Wire Harness from the selling dealership (or refer the customer to the selling dealership).

- **This procedure will be performed on a limited number of vehicles.**

## Procedure A - Vehicles Equipped With Either a Nissan or Valley Industries Tow Hitch:

In this procedure, you'll:

- Remove the original Tow Hitch.
- Mark the Tow Hitch as un-useable.
- Discard the Tow Hitch.
- Install a new Tow Hitch.

Refer to the Parts Information section for the new Tow Hitch part number.

Replace the Tow Hitch as follows:

1. Confirm the tow hitch is either a Nissan P/N 999T5-KR100 or a Valley Industries P/N 2112-00-385 (refer to Figure 1 on the previous page).

2. Remove or lower the Spare Tire/Wheel using the Hand Crank tools from the tool kit (see Figure A1).

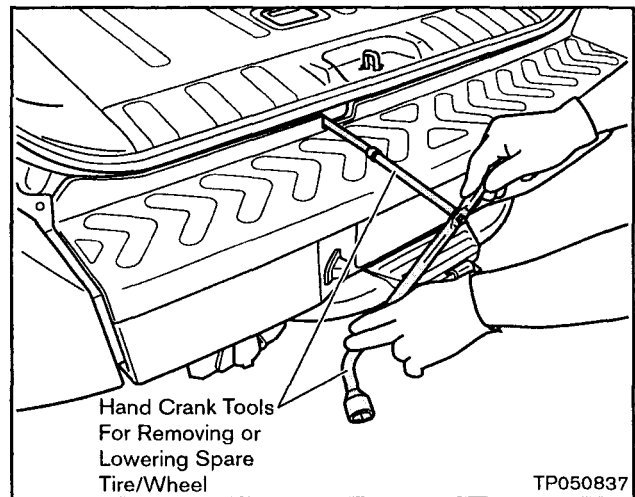

Figure A1

3. Lift the vehicle UP on a hoist.

4. Disconnect the Trailer Lights Wire Harness from the Tow Hitch as follows:

- a. Carefully use needle-nose pliers to release the Harness Tie Wraps from the Tow Hitch. You'll use the Tie Wraps again later (see Figure A2).

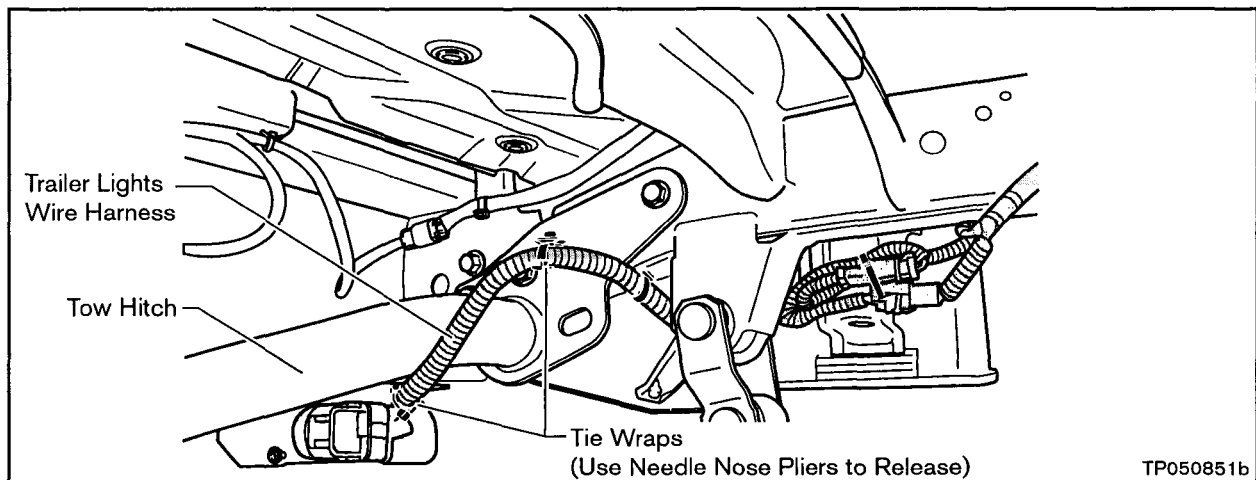

Figure A2

- b. Remove two Bolts/Nuts and remove (slide it DOWN) the Trailer Lights Wire Harness Receptacle from the Tow Hitch (see Figure A3).
- c. You can let the Harness hang from the vehicle frame.

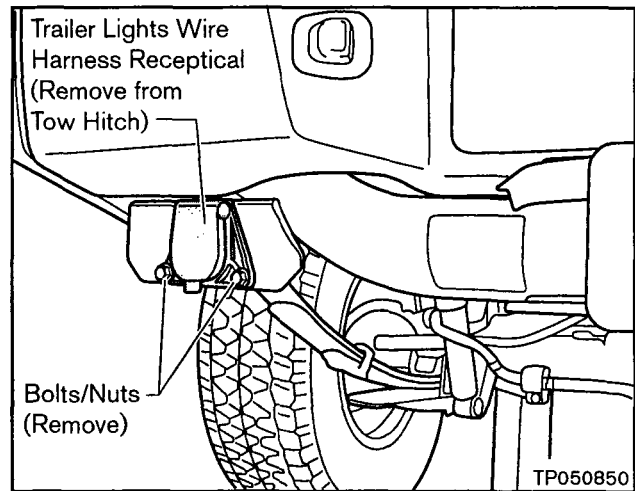

Figure A3

5. Remove three Bolts to disconnect the Rear Exhaust Pipe Hanger from the Frame (see Figure A4).
  - Leave the Hanger attached to the Bracket.

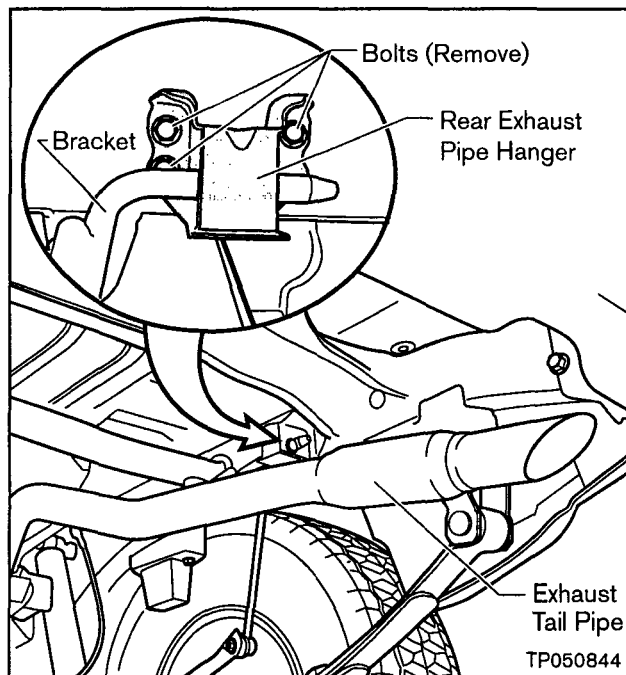

Figure A4

6. Remove the six Bolts that secure the Tow Hitch (see Figure A5).

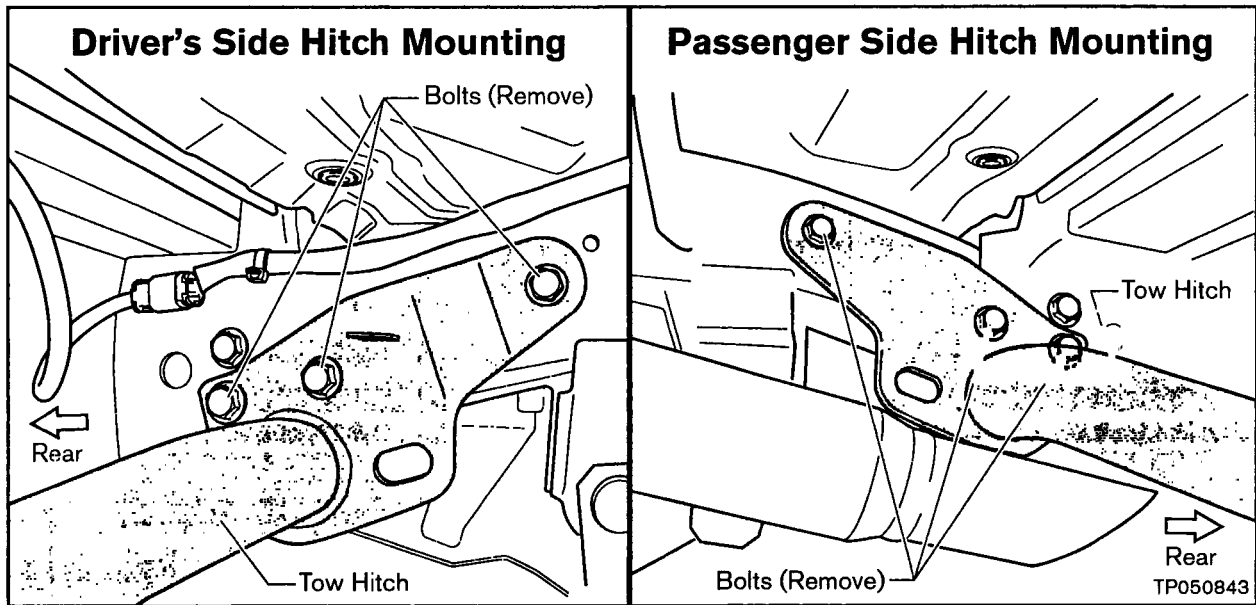

Figure A5

7. Remove the Tow Hitch from the vehicle (see Figure A6).

- When removing, lower the driver's side of the Tow Hitch first.

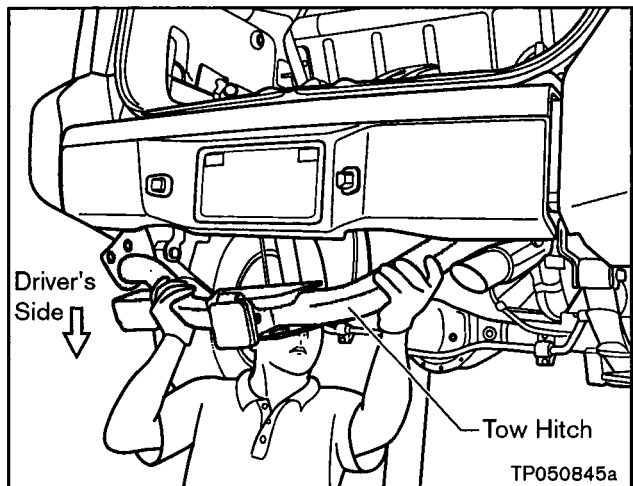

Figure A6

8. Install the new Tow Hitch with six mounting Bolts. Do not tighten the Bolts yet.

**NOTE:** The new Tow Hitch comes with two new mounting Bolts. Install these new Bolts at the locations shown in Figure A7.

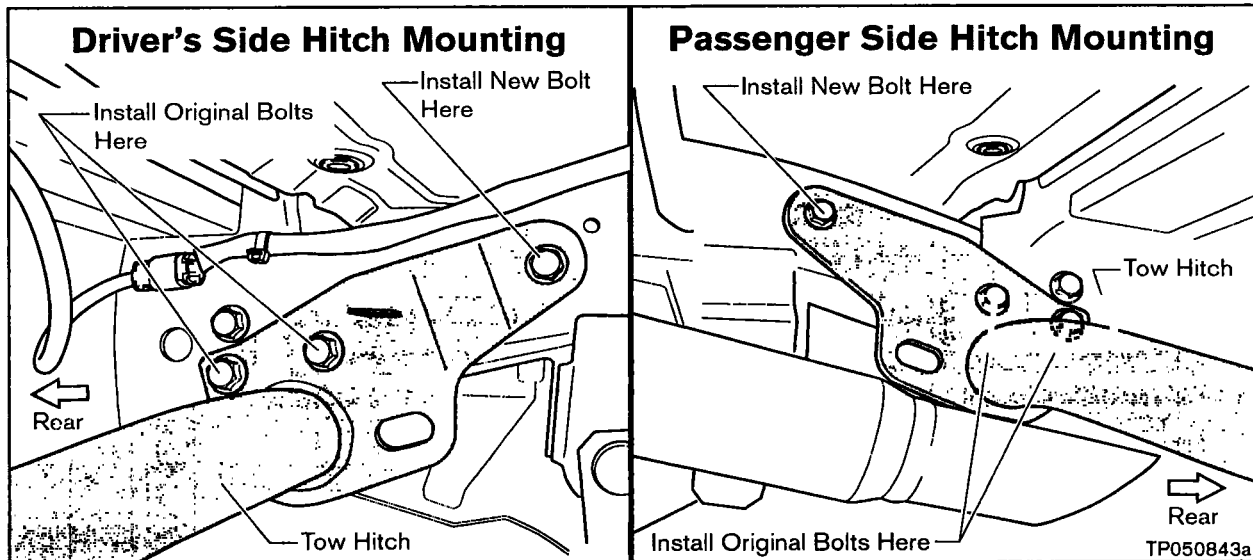

Figure A7

9. Re-install the Rear Exhaust Pipe Hanger and tighten the Bolts to **10 – 15 ft-lb (14 – 20 Nm, 1.38 – 2.07 kg-m)**.

10. Make sure the clearance at the Rear Exhaust Pipe Hanger is at least 4mm (about 5/32 of an inch). See Figure A8.

- If it's less than 4mm, adjust the Exhaust Tail Pipe as needed for proper clearance.

11. Make sure the clearance between the Exhaust Tail Pipe Tip and the Tow Hitch is at least 10mm (about 13/32 of an inch). See Figure A8.

- If it's less than 10mm, adjust the Exhaust Tail Pipe and Tow Hitch as needed for proper clearance.

12. Tighten the Tow Hitch mounting Bolts to: **63 – 85 ft-lb (85–115 Nm, 8.7 – 11.75 kg-m)**.

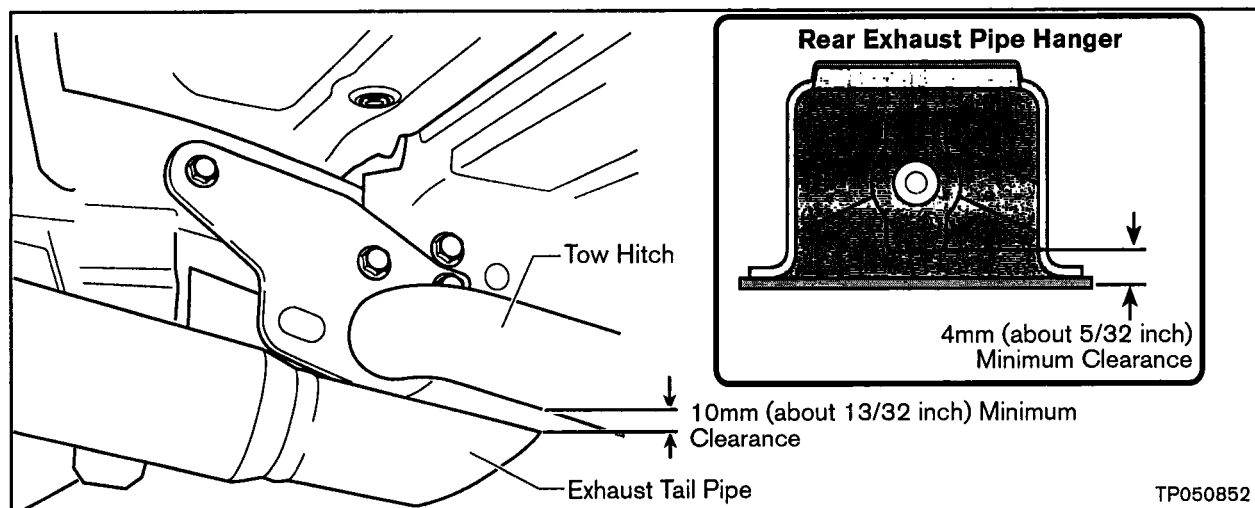

Figure A8

13. Using the two Bolts/Nuts you removed earlier, re-install the Trailer Lights Wire Harness Receptacle to the new Tow Hitch. Then re-insert the harness Tie Wraps into the Tow Hitch.

14. Mark the original Tow Hitch as un-useable per the following procedure:

- a. Using a "cut off wheel" **and suitable hand and eye protection**, remove a section surrounding the Chain Mount Hole as shown in Figure A9. Then cut an "X" in the Tow Hitch surface (about 1/8" deep) as shown in Figure A9.
- b. Spray bright color paint (orange, red, or yellow) over the cut areas (see Figure A9).
- c. Discard the Tow Hitch.

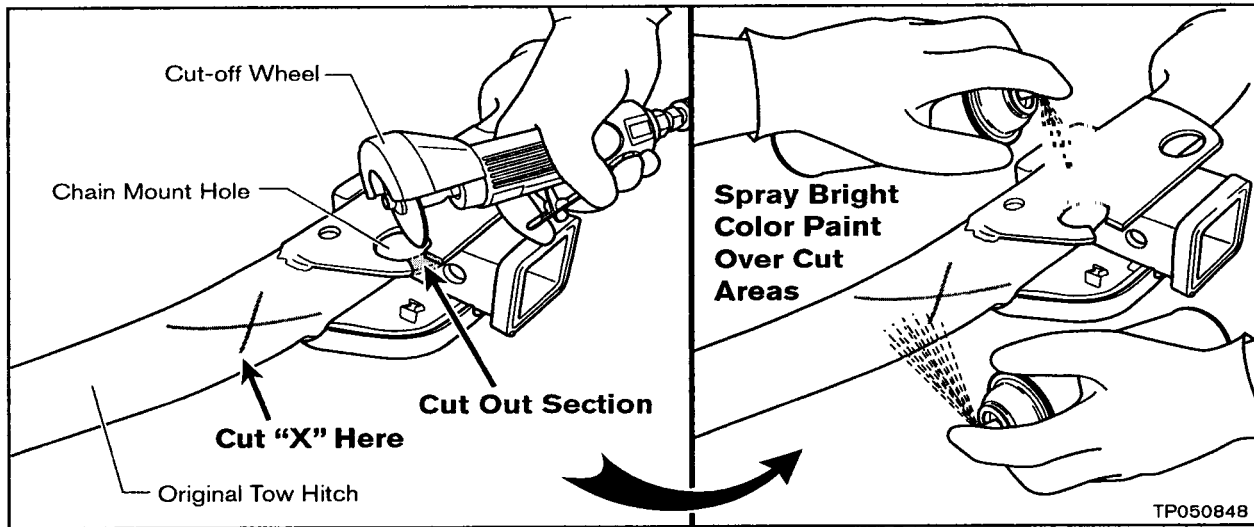

Figure A9

15. Re-install the Spare Tire/Wheel.

## Procedure B - Vehicles With Previously Removed Nissan Tow Hitch (Limited Number of Vehicles):

In this procedure, you'll:

- Obtain the VIN-specific Nissan Tow Hitch Kit components and the Trailer Lights Wire Harness bag that goes with it. These should be stored at the dealership at which the Tow Hitch was removed.

**NOTE:** If you can't find the Tow Hitch Kit and/or the Trailer Lights Wire Harness that were previously removed from the vehicle, you'll need to order new ones:

- ▶ Ball Mount kit P/N 999T5-KL000S1 (includes ball mount/ball mount pin and clip)
- ▶ Trailer Ball P/N 999T7-KN000
- ▶ Hitch Cap P/N 999T5-KN000S2
- ▶ Trailer Lights Wire Harness Kit P/N 999T8-KR000.

Replacement of these parts is the dealer's responsibility. Claims for these parts will not be processed.

- Install a new Tow Hitch.
1. Obtain the components shown in Figure B1.
    - They should be stored in the Parts Department.
    - The applicable VIN for the vehicle you are working on should be written on the outside of the box/bag.

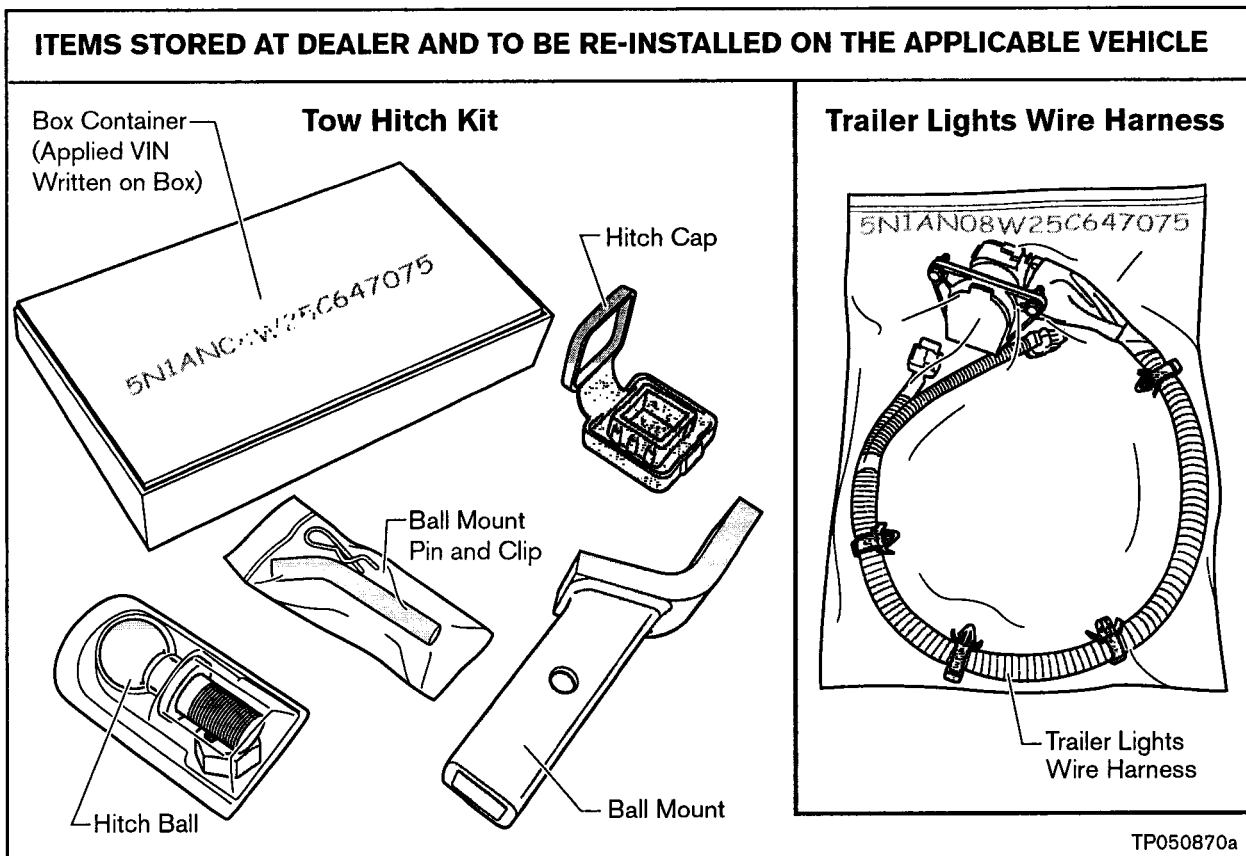

Figure B1



2. Remove or lower the Spare Tire/Wheel using the Hand Crank tools from the tool kit (see Figure B2).

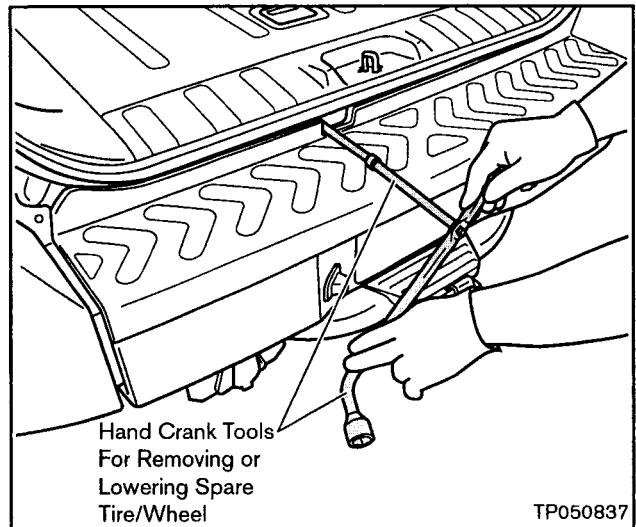

Figure B2

3. Lift the vehicle UP on a hoist.

4. Remove six Bolts from the Frame as shown in Figure B3.

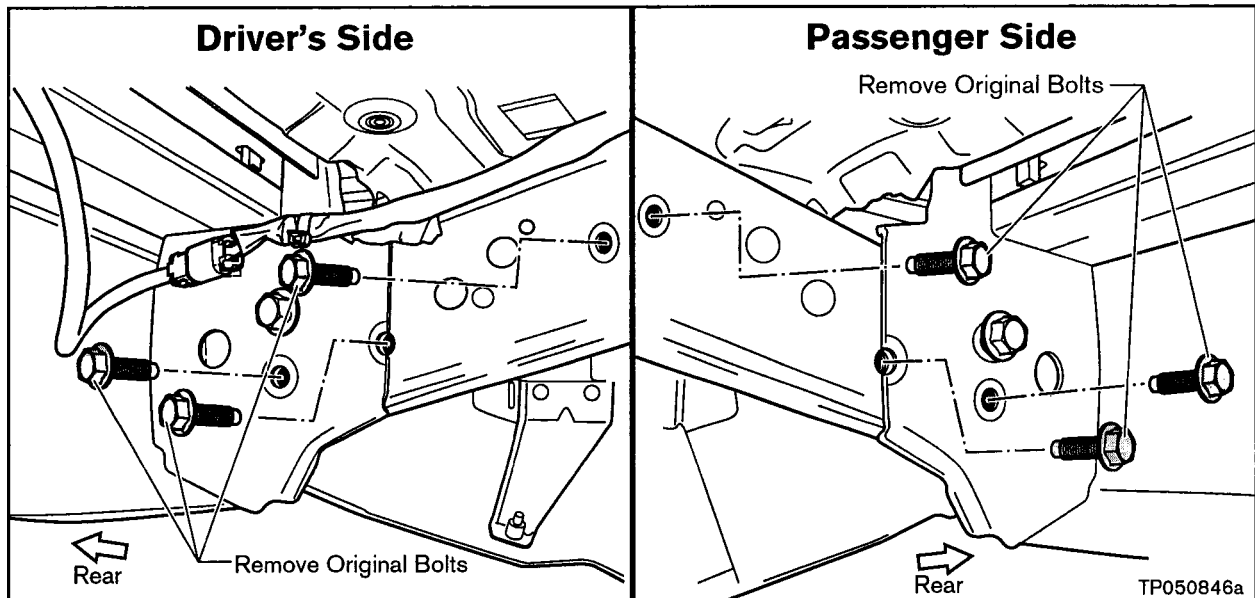

Figure B3

5. Remove three Bolts to disconnect the Rear Exhaust Pipe Hanger from the Frame (see Figure B4).

- Leave the Hanger attached to the Bracket.

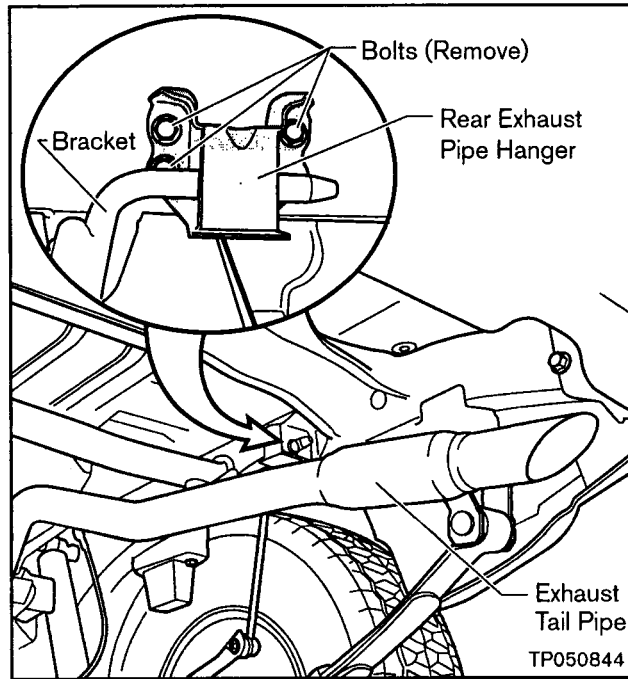

Figure B4

6. Install the new Tow Hitch with six mounting Bolts. Do not tighten the Bolts yet.

**NOTE:** The new Tow Hitch comes with two new mounting Bolts. Install these new Bolts at the locations shown in Figure B5.

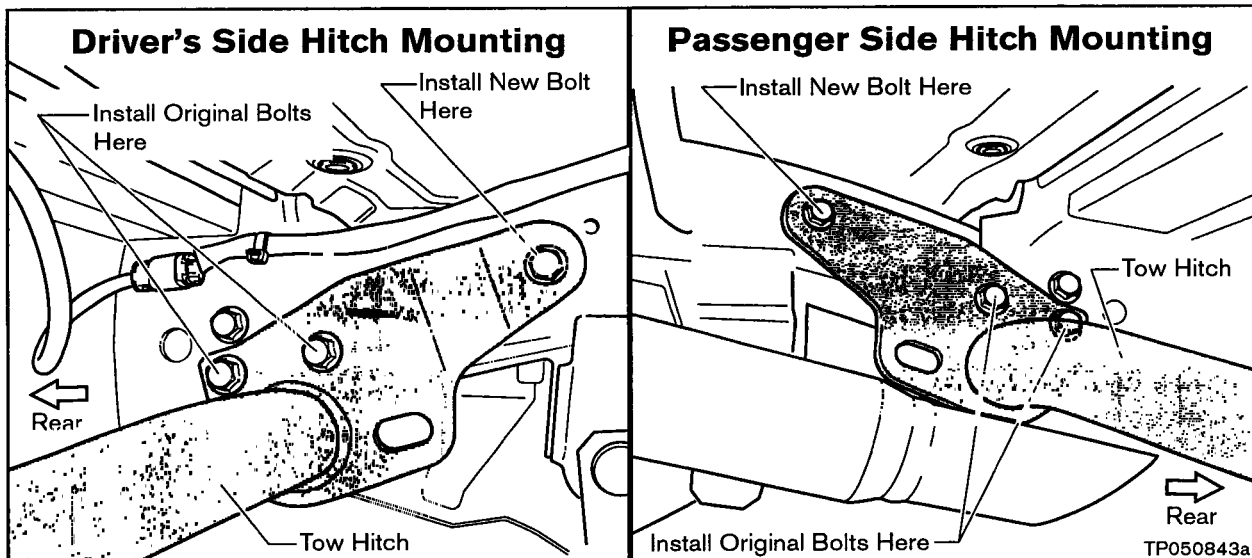

Figure B5

7. Re-install the Rear Exhaust Pipe Hanger and tighten the Bolts to **10 – 15 ft-lb (14 – 20 Nm, 1.38 – 2.07 kg-m)**.
8. Make sure the clearance at the Rear Exhaust Pipe Hanger is at least 4mm (about 5/32 of an inch). See Figure B6.
  - If it's less than 4mm, adjust the Exhaust Tail Pipe as needed for proper clearance.
9. Make sure the clearance between the Exhaust Tail Pipe Tip and the Tow Hitch is at least 10mm (about 13/32 of an inch). See Figure B6.
  - If it's less than 10mm, adjust the Exhaust Tail Pipe and Tow Hitch as needed for proper clearance.
10. Tighten the Tow Hitch mounting Bolts to: **63 – 85 ft-lb (85–115 Nm, 8.7 – 11.75 kg-m)**.

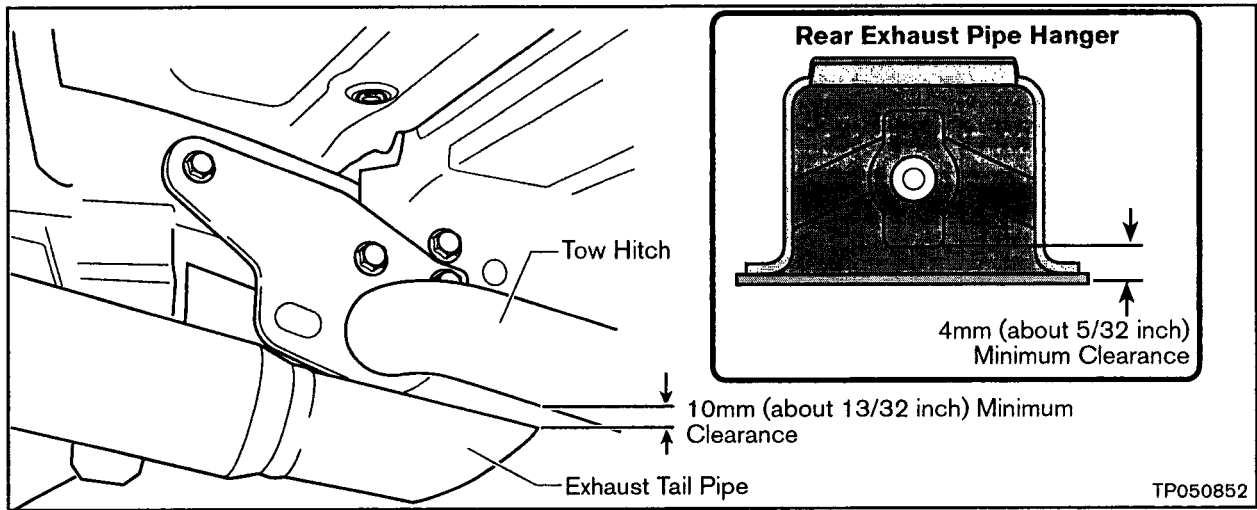

Figure B6

11. Install the Trailer Lights Wire Harness (Tow Hitch side) as follows:

- a. Remove the Connector Plugs from the Trailer Lights Wire Harness (vehicle side). See Figure B7

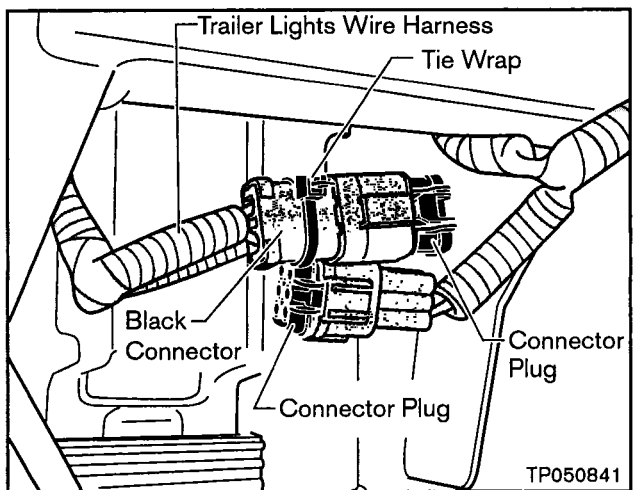

Figure B7

- b. Remove two damaged Tie Wraps from the Trailer Lights Wire Harness (see Figure B8). These were cut when the harness was previously removed from the vehicle. Then install two new Tie Wraps in the exact same locations.

**Tie Wrap P/N: 24225-89960**

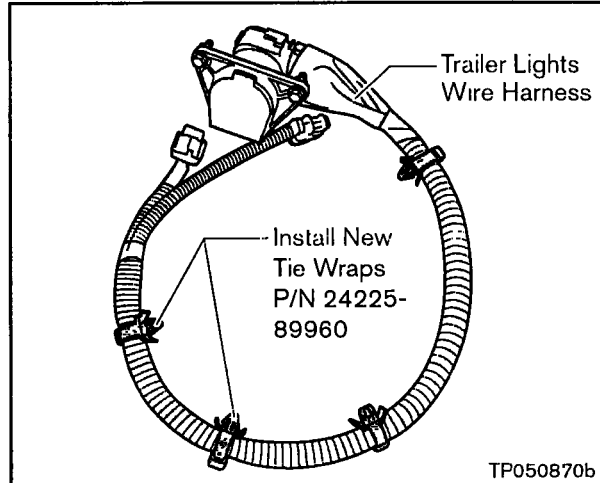

Figure B8

- c. Install the Trailer Lights Wire Harness Receptacle to the Tow Hitch. Use the two Bolts/Nuts already installed in the receptacle (see Figure B9).

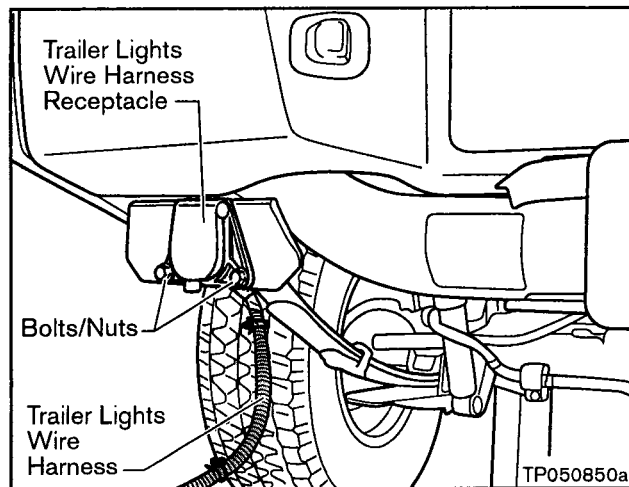

Figure B9

- d. Route and connect the Trailer Lights Wire Harness to the vehicle as shown in Figure B10.

**CAUTION:** Make sure the harness is routed and secured as shown in Figure B10, especially around the leaf spring support.

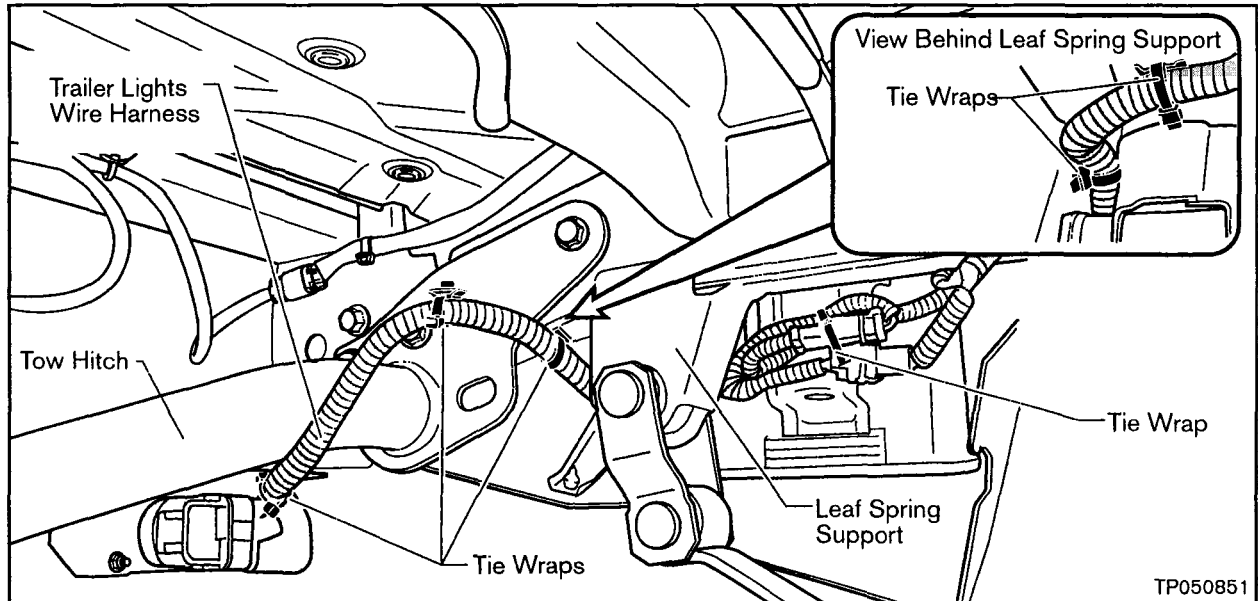

Figure B10

12. Re-install the Spare Tire/Wheel.

13. Make sure the Tow Hitch Kit (shown in Figure B1) is returned to the customer.

## PARTS INFORMATION

DESCRIPTION	PART NUMBER	QUANTITY
Tow Hitch *	999T5-KR200	1
Tie Wrap **	24225-89960	2

\* A Valley Industries Tow Hitch will be replaced with a Nissan Tow Hitch.

\*\* Only needed for Trailer Lights Wire Harnesses that were removed and stored at the dealership (Procedure B).

## CLAIMS INFORMATION

Submit a Campaign (CM) line claim using the following claims coding:

“CM” I.D.: PB009

DESCRIPTION	OP CODE	FRT
RPL or Install Nissan Tow Hitch	PB0090	0.5 hrs

OR:

DESCRIPTION	OP CODE	FRT
RPL Valley Industries Tow Hitch	PB0091	0.5 hrs

**NOTE:** Claim only ONE of the operations listed above.

## OWNER'S LETTER (A)

This letter was mailed to owners of vehicles with factory installed Nissan tow hitches only.

Dear Nissan Owner:

This notice is sent to you in accordance with the requirements of the National Traffic and Motor Vehicle Safety Act. Nissan has decided that a defect that relates to motor vehicle safety exists in some 2005 model year Nissan Xterra vehicles equipped with a Nissan accessory tow hitch.

### Reason for Recall

Our records indicate that your Xterra is equipped with a Nissan accessory tow hitch. This tow hitch may not have been manufactured properly. If you use the tow hitch, this could result in the trailer separating from the vehicle and cause a crash without warning.

### What Nissan Will Do

Nissan is now in the process of having new tow hitches manufactured and anticipates having them available in mid-November. We will notify you when a new hitch is available and your Nissan dealer will replace the hitch with a new one free of charge.

### What You Should Do

**Do not use the tow hitch on your vehicle until it is replaced with the new one.** If you have additional questions you may contact the National Consumer Affairs Office, Nissan North America, Inc. at P.O. Box 191, Gardena, California 90248-0191. The toll free number is (800) 647-7261.

You may also submit a complaint to the Administrator, National Highway Traffic Safety Administration, 400 Seventh Street, SW., Washington, DC 20590; or call the toll-free Vehicle Safety Hotline at 1-888-327-4236 (TTY: 1-800-424-9153); or go to <http://www.safercar.gov>.

Federal law requires that any vehicle lessor receiving this recall notice must forward a copy of this notice to the lessee within ten days.

Thank you for your cooperation. We are indeed sorry for any inconvenience this may cause you.

## OWNER'S LETTER (B)

This letter was mailed to all 2005 Xterra owners, except those who received letter A.

Dear Nissan Owner:

This notice is sent to you in accordance with the requirements of the National Traffic and Motor Vehicle Safety Act. Nissan has decided that a defect that relates to motor vehicle safety exists in some 2005 model year Nissan Xterra vehicles equipped with a Nissan accessory tow hitch manufactured by Valley Industries. Valley Industries has also decided that some tow hitches it distributed for use on the 2005 Xterra are defective.

### Reason for Recall

The tow hitches sold by Nissan dealers or through Valley Industries distributors for installation on 2005 model year Nissan Xterra vehicles may not have been manufactured properly. If you use the tow hitch, this could result in the trailer separating from the vehicle and cause a crash without warning. This recall pertains to you if a Nissan accessory tow hitch, which has a label attached with the Nissan part number 999T5-KR100, or a Valley Industries tow hitch, which has a label attached with the part number 2112-00-385, was installed on your vehicle at the time of vehicle purchase or at a later date.

If your vehicle is not equipped with a Nissan accessory tow hitch or Valley Industries tow hitch with the above noted part numbers, please return the enclosed pre-paid post card that has your name, address and vehicle identification number printed on it.

### What Nissan Will Do

Nissan is now in the process of having new tow hitches manufactured and anticipates having them available in mid-November. If your vehicle is equipped with a Nissan accessory tow hitch or Valley Industries tow hitch, we will notify you when a new hitch is available and your Nissan dealer will replace the hitch with a new one free of charge.

### What You Should Do

**If you have a Nissan accessory tow hitch or Valley Industries tow hitch on your vehicle do not use it until it is replaced with the new one.** If you have additional questions you may contact the National Consumer Affairs Office, Nissan North America, Inc. at P.O. Box 191, Gardena, California 90248-0191. The toll free number is (800) 647-7261.

You may also submit a complaint to the Administrator, National Highway Traffic Safety Administration, 400 Seventh Street, SW., Washington, DC 20590; or call the toll-free Vehicle Safety Hotline at 1-888-327-4236 (TTY: 1-800-424-9153); or go to <http://www.safercar.gov>.

Federal law requires that any vehicle lessor receiving this recall notice must forward a copy of this notice to the lessee within ten days.

Thank you for your cooperation. We are indeed sorry for any inconvenience this may cause you.



## OWNER'S LETTER (C)

This letter is being mailed to all 2005 Xterra owners, except in cases where the tow hitch was already replaced with a new one or if the owner returned a post card indicating the vehicle does not have a Nissan or Valley Industries tow hitch installed.

Dear Nissan Owner:

This letter is a follow-up to one you may have received earlier that was sent to you in accordance with the requirements of the National Traffic and Motor Vehicle Safety Act. Nissan has decided that a defect that relates to motor vehicle safety exists in some 2005 model year Nissan Xterra vehicles equipped with a Nissan accessory tow hitch. Valley Industries has also decided that some tow hitches it distributed for use on the 2005 Xterra are defective. Replacement hitches are now available, and you can contact your Nissan dealer to arrange an appointment to have the replacement installed.

### Reason for Recall

The tow hitches sold by Nissan dealers or through Valley Industries distributors for installation on 2005 model year Nissan Xterra vehicles may not have been manufactured properly. If you use the tow hitch, this could result in the trailer separating from the vehicle and cause a crash without warning. This recall pertains to you if a Nissan accessory tow hitch, which has a label attached with the Nissan part number 999T5-KR100, or a Valley Industries tow hitch, which has a label attached with the part number 2112-00-385, was installed on your vehicle at the time of vehicle purchase or at a later date.

If your vehicle is not equipped with a Nissan accessory tow hitch or Valley Industries tow hitch with the above noted part numbers, this notice does not apply to you, and no further action is required.

### What Nissan Will Do

If your Xterra is equipped with the Nissan accessory or a Valley Industries tow hitch, your Nissan dealer will replace the tow hitch with a new one free of charge. This free service should take about one hour to complete, but your Nissan dealer may require your vehicle for a longer period of time based upon their work schedule.

### What You Should Do

**Do not use the tow hitch on your vehicle until it is replaced with the new one.** Contact your Nissan dealer at your earliest convenience in order to arrange an appointment to have your vehicle repaired. Please bring this notice with you when you keep your service appointment. Instructions have been sent to your Nissan dealer. If you have additional questions you may contact the National Consumer Affairs Office, Nissan North America, Inc. at P.O. Box 191, Gardena, California 90248-0191. The toll free number is (800) 647-7261.

You may also submit a complaint to the Administrator, National Highway Traffic Safety Administration, 400 Seventh Street, SW., Washington, DC 20590; or call the toll-free Vehicle Safety Hotline at 1-888-327-4236 (TTY: 1-800-424-9153); or go to <http://www.safercar.gov>.

Federal law requires that any vehicle lessor receiving this recall notice must forward a copy of this notice to the lessee within ten days.

Thank you for your cooperation. We are indeed sorry for any inconvenience this may cause you.