

**GM SERVICE AND PARTS OPERATIONS
DCS1463
URGENT DISTRIBUTE IMMEDIATELY**

Date: October 6, 2005

Subject: 05086 Product Safety Recall
 Power Steering Hose Fracture

Models: 2006 Buick Rainier
 2006 Cadillac Escalade
 2005 Chevrolet Corvette, Silverado
 2006 Chevrolet Corvette, Express, Silverado, Tahoe,
 TrailBlazer, TrailBlazer EXT
 2005 GMC Sierra
 2006 GMC Envoy, Envoy XL, Savana, Sierra, Yukon
 2006 Hummer H2

To: All Buick, Cadillac, Chevrolet, GMC and Hummer Dealers

Attention: Service Manager, Parts Manager and Warranty Administrator

PRODUCT FIELD ACTION ANNOUNCEMENT

General Motors is announcing Product Safety Recall 05086 today. The total number of vehicles involved is 136,899. Please see the attached bulletin for details.

Mailing Information

Customer notification letter mailing will begin on October 14, 2005.

GM Vehicle Inquiry System (GMVIS)

GMVIS information will be available on October 6, 2005.

Service Information System (SI)

Bulletin 05086 is scheduled to be available on October 7, 2005.

Campaign Initiation Detail Report (CIDR)

The CIDR will be available in GM DealerWorld on October 13, 2005.

PLEASE DOUBLE CLICK ON THE ICON BELOW
THEN SINGLE CLICK ON THE LAUNCH BUTTON
TO VIEW OR PRINT THE BULLETIN

(See attached file: 05086 bulletin.pdf)

END OF MESSAGE
GM SERVICE AND PARTS OPERATIONS



File In Section: Product Recalls
Bulletin No.: 05086
Date: October 2005

Recall Bulletin



PRODUCT SAFETY RECALL

SUBJECT: POWER STEERING HOSE FRACTURE

**MODELS: 2006 BUICK RAINIER
2006 CADILLAC ESCALADE
2005 CHEVROLET CORVETTE, SILVERADO
2006 CHEVROLET CORVETTE, EXPRESS, SILVERADO, TAHOE,
TRAILBLAZER, TRAILBLAZER EXT
2005 GMC SIERRA
2006 GMC ENVOY, ENVOY XL, SAVANA, SIERRA, YUKON
2006 HUMMER H2**

CONDITION

General Motors has decided that a defect, which relates to motor vehicle safety, exists in **certain** 2005 Chevrolet Corvette, Silverado; GMC Sierra; and 2006 Buick Rainier; Cadillac Escalade, Chevrolet Corvette, Express, Silverado, Tahoe, TrailBlazer, TrailBlazer EXT; GMC Envoy, Envoy XL, Savana, Sierra, Yukon; and HUMMER H2 vehicles. Some of these vehicles may have been built with a power steering hose that is not to specification. Under extreme steering maneuvers, such as turning the steering wheel fully to the left or right while braking, the hose may fracture and leak fluid. If this were to occur, power steering assist would be lost and increased steering effort would be required. On vehicles equipped with hydro-boost power brakes, it could also result in loss of power brake assist and increased braking effort would be required. If the power steering fluid spray were to spray onto hot engine parts, an engine compartment fire could occur.

CORRECTION

Dealers are to inspect the power steering hose(s) for two suspect date codes and replace them if required.

VEHICLES INVOLVED

Involved are **certain** 2005 Chevrolet Corvette, Silverado; GMC Sierra; and 2006 Buick Rainier; Cadillac Escalade, Chevrolet Corvette, Express, Silverado, Tahoe, TrailBlazer, TrailBlazer EXT; GMC Envoy, Envoy XL, Savana, Sierra, Yukon; and HUMMER H2 vehicles built within the VIN breakpoints listed below.

Important: Some of the affected hoses were shipped to dealers by GMSPO between July 25, 2005 and August 24, 2005 and could have been used to service 1991 - 2006 vehicles. Affected dealers have already been issued a Special Return Bulletin to return any shelf stock, refer to Administrative Message VSU20050801 - GMP05 -157. An additional message will be sent to dealers by GMSPO to address identifying any vehicles that may have been serviced with an affected hose.

YEAR	DIVISION	MODEL	FROM	THROUGH
2006	Buick	Rainier	62108125	62136350
2006	Cadillac	Escalade	6R104437	6R120470
2005	Chevrolet	Corvette	55132486	55135514
2006	Chevrolet	Corvette	65100198	65100359
2006	Chevrolet	Express	61100118	61124506
2005	Chevrolet	Silverado	5E338138	5E345047
2006	Chevrolet	Silverado	61100191	61138454
			6E100114	6E112187
			6F100087	6F118931
			6M100351	6M102015
2006	Chevrolet	Tahoe	6R104438	6R120469
2006	Chevrolet	TrailBlazer	62105375	62136709
2006	Chevrolet	TrailBlazer EXT	66100171	66112957
2006	GMC	Envoy	62105380	62136702
2006	GMC	Envoy XL	66100172	66112890
2006	GMC	Savana	61100138	61123886
2005	GMC	Sierra	5E338137	5E345050
2006	GMC	Sierra	61100257	61138467
			6E100117	6E112129
			6F101423	6F118925
			6Z104646	6Z126329
2006	GMC	Yukon	6R104469	6R120468
2006	HUMMER	H2	6H100466	6H103284

IMPORTANT: Dealers should confirm vehicle eligibility through **GMVIS** (GM Vehicle Inquiry System) prior to beginning recall repairs. [Not all vehicles within the above breakpoints may be involved.]

For US and Canada: For dealers involved vehicles, a Campaign Initiation Detail Report (CIDR) containing the complete vehicle identification number, customer name and address data has been prepared and will be loaded to the GM DealerWorld (US) Recall Information, GMInfoNet (Canada) Recall Reports. Dealers will not have a report available if they have no involved vehicles currently assigned.

For Export: For dealers with involved vehicles, a Campaign Initiation Detail Report containing the complete vehicle identification number, customer name and address data has been prepared, and is being furnished to involved dealers. Dealers will not receive a report with the recall bulletin if they have no involved vehicles currently assigned.

The Campaign Initiation Detail Report may contain customer names and addresses obtained from Motor Vehicle Registration Records. The use of such motor vehicle registration data for any purpose other than follow-up necessary to complete this recall is a violation of law in several states/provinces/countries. Accordingly, you are urged to limit the use of this report to the follow-up necessary to complete this recall.

PARTS INFORMATION

Less than 10% of the involved vehicles will require hose replacement. If parts are required, order the appropriate hose(s) from General Motors Service Parts Operations (GMSPO). Normal orders should be placed on a DRO = Daily Replenishment Order. In an emergency situation, parts should be ordered on a CSO = Customer Special Order.

SERVICE PROCEDURE

Inspection Procedure

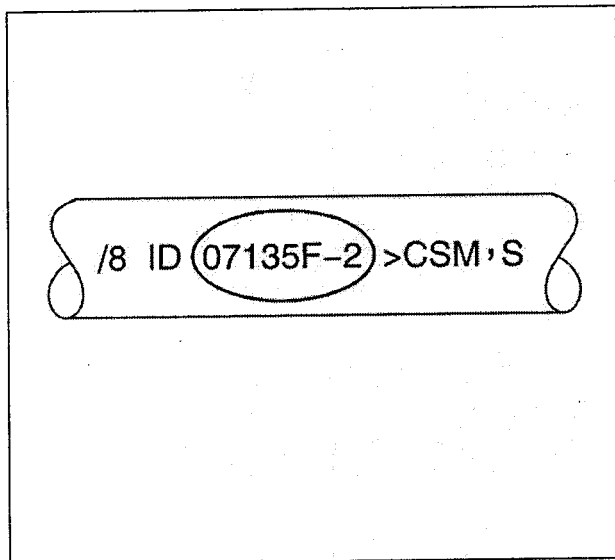

1704027

1. Inspect and record the power steering pressure line for the date code as shown above. The date code is printed on the hose and is repeated approximately every 6 inches (150 mm). Depending on the vehicle configuration, there may be one or two hoses to inspect. Vehicles equipped with the hydro-boost system will have two hoses while others will only have one hose. Removal of conduit may be necessary in order to inspect the date code.

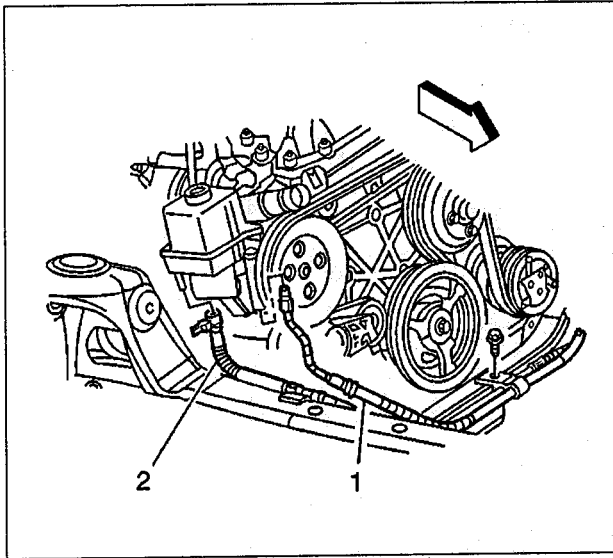

687439

Rainier/TrailBlazer/TrailBlazer EXT/Envoy/Envoy XL with 4.2L Engine Power Steering Pressure Hose (1). This pressure line has two hose sections and both must be inspected. Vehicle may need to be lifted to inspect both.

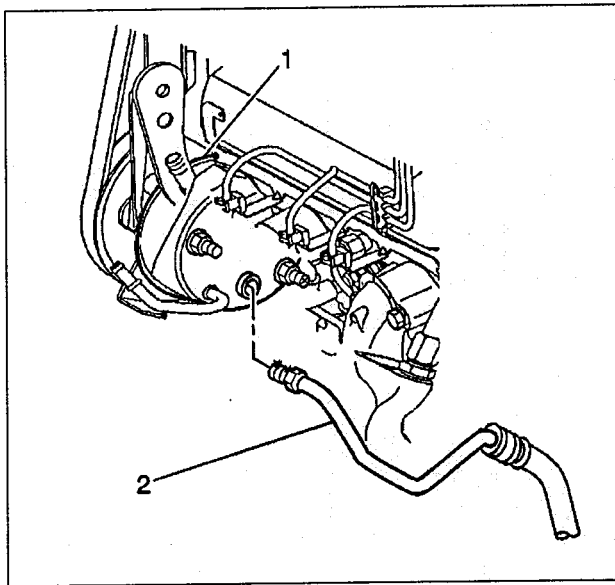

309298

Express/Savana Steering Pump to Hydro-Boost Pressure Line (2)

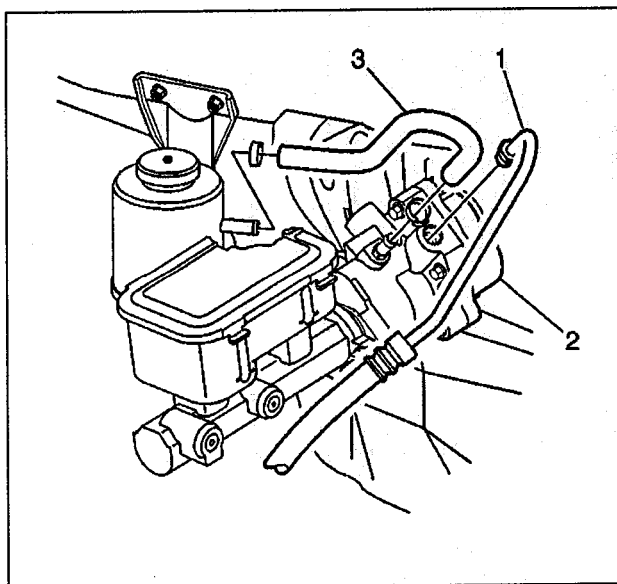

407982

Express/Savana Hydro-Boost to Steering Gear Pressure Line (1).

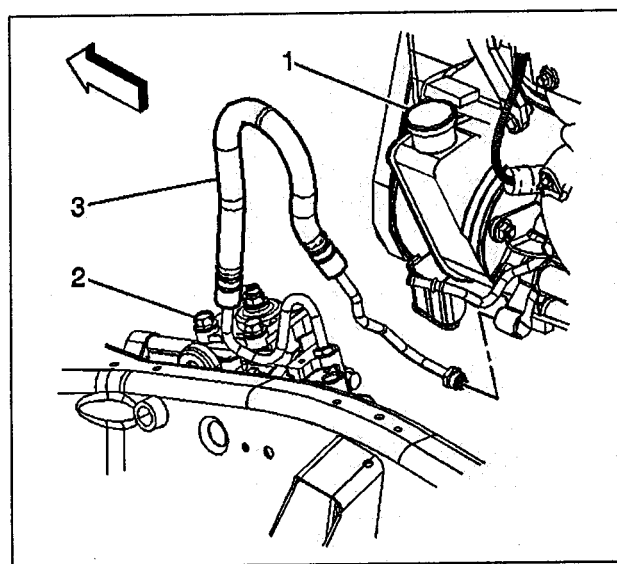

748675

Silverado/Tahoe/Sierra/Yukon/Escalade Non Hydro-Boost Pressure Line (3).

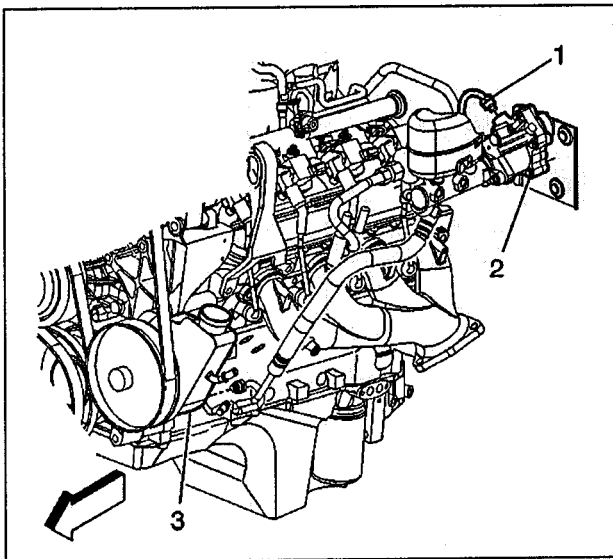

650858

Silverado/Tahoe/Sierra/Yukon/Escalade Power Steering Pump to Hydro-Boost Pressure Line (1).

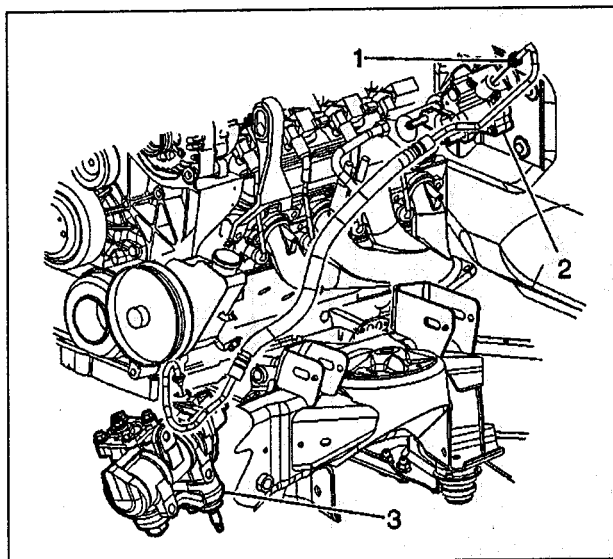

650863

Silverado/Tahoe/Sierra/Yukon/Escalade Hydro-Boost to Steering Gear Pressure Line (1).

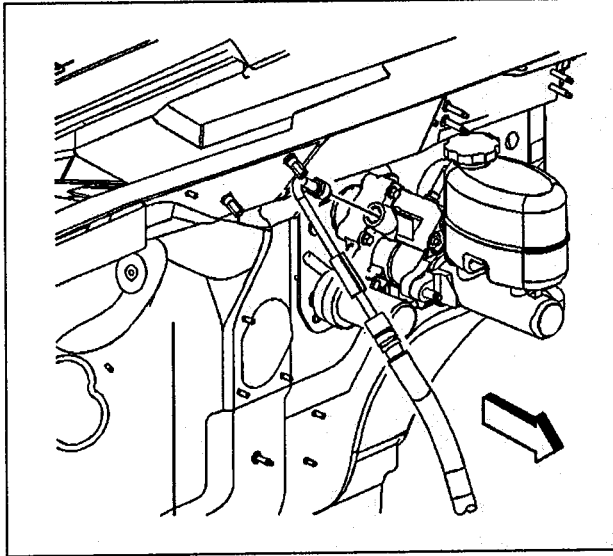

795542

Hummer H2 Power Steering Pump to Hydro-Boost Pressure Line.

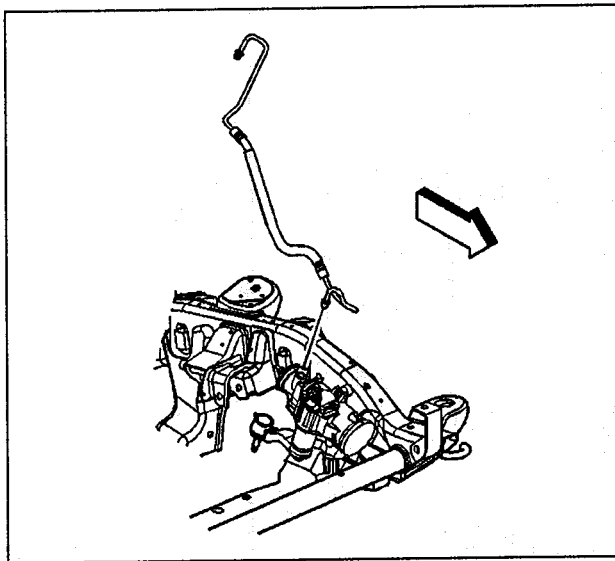

793265

Hummer H2 Hydro-Boost to Steering Gear Pressure Line.

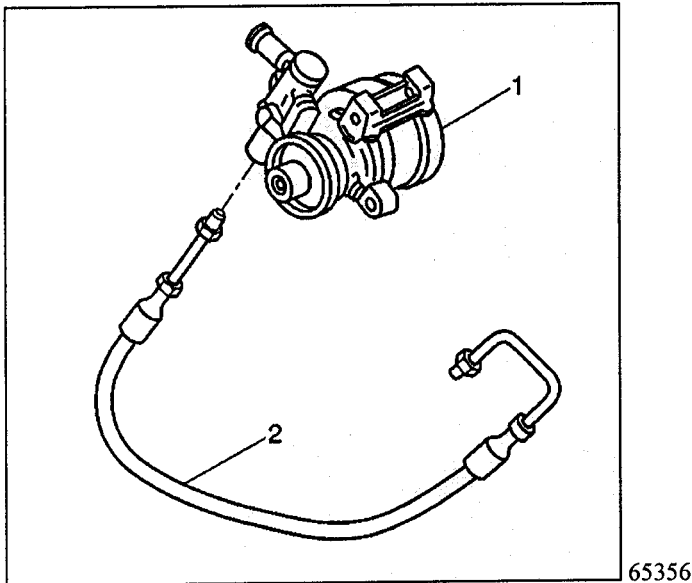

65356

Corvette Power Steering Pressure Hose (2). The vehicle will need to be lifted on a hoist for inspection. Removal of the power steering cooler bolts will give increased access to the pressure hose.

2. Compare the date code on the hose(s) to the suspect date codes below.

Suspect Date Codes	
07135F-2	07145F-2

- If the date code is one of the codes listed above, the hose(s) must be replaced. Proceed to the Hose Replacement Procedure.
- If the date code is not one of the codes listed above, then replace the conduit if applicable and no further action is required.

Hose Replacement Procedure

If the inspection reveals that the hose needs to be replaced, follow the instructions in SI. Referenced below are the SI document numbers.

Vehicle	Hose	SI Document #
Rainier/TrailBlazer/TrailBlazer EXT/Envoy/Envoy XL	Power Steering Pressure Hose	847857 (follow instructions through the removal procedure to remove the power steering hose assembly. Replace the pressure hose in the assembly on the bench. Use due care when opening and closing the line position brackets to avoid damaging them. Proceed with installation instructions.

Vehicle	Hose	SI Document #
Express/Savana	Steering Pump to Hydro-Boost Pressure Line	826927
	Hydro-Boost to Steering Gear Pressure Line	826928
Silverado/Tahoe/Sierra/Yukon /Escalade	Non Hydro-Boost Pressure line	756552
	Power Steering Pump to Hydro-Boost Pressure line	651043
	Hydro-Boost to Steering Gear Pressure Line	651019
	Power Steering Gear Inlet and Outlet Hose Replacement (Non Rack and Pinion)	1261597
	Power Steering Gear Inlet Pipe/Hose Replacement (Rack and Pinion)	736576
Hummer H2	Power Steering Pump to Hydro-Boost Pressure line.	796679
	Hummer H2 Hydro-Boost to Steering Gear Pressure Line.	796621
Corvette	Power Steering Pressure Hose	664664

COURTESY TRANSPORTATION – For US and Canada

The General Motors Courtesy Transportation Program is intended to minimize customer inconvenience when a vehicle requires a repair that is covered by the New Vehicle Limited Warranty. The availability of courtesy transportation to customers whose vehicles are within the warranty coverage period and involved in a product recall is very important in maintaining customer satisfaction. Dealers are to ensure that these customers understand that shuttle service or some other form of courtesy transportation is available and will be provided at no charge. Dealers should refer to the General Motors Service Policies and Procedures Manual for courtesy transportation guidelines.

CLAIM INFORMATION

Submit a Product Recall Claim with the information indicated below:

REPAIR PERFORMED	PART COUNT	PART NO.	PARTS ALLOW	CC-FC	LABOR OP	LABOR HOURS
Inspect Hose(s) Only - No Further Action Required	N/A	N/A	N/A	MA-96	V1415	
• Rainier, Corvette, TrailBlazer, TrailBlazer EXT, Envoy, Envoy XL						0.3
• Escalade, Express, Silverado, Tahoe, Savana, Sierra, Yukon, H2						0.2
Inspect & Replace Hose(s)	1	---	*		V1416	
• Rainier, TrailBlazer, TrailBlazer Ext, Envoy, Envoy XL	1					2.7
• Express, Savana						
- Pump to Hydro-Boost	1					0.9
- Hydro-Boost to Steering Gear	1					0.8
- Both	2					1.0
• Escalade, Silverado, Tahoe, Sierra, Yukon (Non-Hydro-Boost)	1					0.8
• Escalade, Silverado, Tahoe, Sierra, Yukon (Hydro-Boost)						
- Pump to Hydro-Boost	1					0.8
- Hydro-Boost to Steering Gear	1					0.7
- Both	2					0.9
• Corvette	1					2.4
• H2	1					
- Pump to Hydro-Boost	1					0.8
- Hydro-Boost to Steering Gear	1					0.7
- Both	2					0.9
Courtesy Transportation for vehicles within the New Vehicle Limited Warranty (US & Canadian GM Dealers)	N/A	N/A	N/A	MA-96	**	N/A
Inspect or Inspect & Replace hose(s) on vehicles identified by dealer record search as repaired outside of warranty	0-3	---	*	MA-96	T5635	***

* The "Parts Allowance" should be the sum total of the current GMSPD Dealer net price plus applicable Mark-Up or Landed Cost Mark-Up (for Export) for the hose(s) and hydraulic power steering fluid needed to complete the repair.

** Submit courtesy transportation using normal labor operations for courtesy transportation as indicated in the GM Service Policies and Procedures Manual for vehicles within the New Vehicle Limited Warranty.

*** Submit the appropriate labor time as indicated in the table and add 0.3 labor hours for search of owner name & address and costs incurred to mail the owner a letter.

Refer to the General Motors WINS Claims Processing Manual for details on Product Recall Claim Submission.

CUSTOMER NOTIFICATION – For US and Canada

General Motors will notify customers of this recall on their vehicle (see copy of customer letter included with this bulletin). For vehicles with the recalled component installed on their vehicles outside of warranty, dealers are to notify customers of this recall using a copy of the letter contained in this bulletin.

CUSTOMER NOTIFICATION – For Export

Letters will be sent to known owners of record located within areas covered by the US National Traffic and Motor Vehicle Safety Act. For owners outside these areas, dealers should notify customers using the attached sample letter.

DEALER RECALL RESPONSIBILITY – For US and Export (US States, Territories, and Possessions)

The US National Traffic and Motor Vehicle Safety Act provides that each vehicle that is subject to a recall of this type must be adequately repaired within a reasonable time after the customer has tendered it for repair. A failure to repair within sixty days after tender of a vehicle is prima facie evidence of failure to repair within a reasonable time. If the condition is not adequately repaired within a reasonable time, the customer may be entitled to an identical or reasonably equivalent vehicle at no charge or to a refund of the purchase price less a reasonable allowance for depreciation. To avoid having to provide these burdensome remedies, every effort must be made to promptly schedule an appointment with each customer and to repair their vehicle as soon as possible. In the recall notification letters, customers are told how to contact the US National Highway Traffic Safety Administration if the recall is not completed within a reasonable time.

DEALER RECALL RESPONSIBILITY – All

All unsold new vehicles in dealers' possession and subject to this recall must be held and inspected/repaired per the service procedure of this recall bulletin before customers take possession of these vehicles.

Dealers are to service all vehicles subject to this recall at no charge to customers, regardless of mileage, age of vehicle, or ownership, from this time forward.

Customers who have recently purchased vehicles sold from your vehicle inventory, and for which there is no customer information indicated on the dealer listing, are to be contacted by the dealer. Arrangements are to be made to make the required correction according to the instructions contained in this bulletin. A copy of the customer letter is provided in this bulletin for your use in contacting customers. Recall follow-up cards should not be used for this purpose, since the customer may not as yet have received the notification letter.

In summary, whenever a vehicle subject to this recall enters your vehicle inventory, or is in your dealership for service in the future, you must take the steps necessary to be sure the recall correction has been made before selling or releasing the vehicle.



October 2005

Dear General Motors Customer:

This notice is sent to you in accordance with the requirements of the National Traffic and Motor Vehicle Safety Act.

Reason For This Recall: General Motors has decided that a defect, which relates to motor vehicle safety, exists in certain 2005 Chevrolet Corvette, Silverado; GMC Sierra; and 2006 Buick Rainier; Cadillac Escalade, Chevrolet Corvette, Express, Silverado, Tahoe, TrailBlazer, TrailBlazer EXT; GMC Envoy, Envoy XL, Savana, Sierra, Yukon; and HUMMER H2 vehicles. Some of these vehicles may have been built with a power steering hose that is not to specification. Under extreme steering maneuvers, such as turning the steering wheel fully to the left or right while braking, the hose may fracture and leak fluid. If this were to occur, power steering assist would be lost and increased steering effort would be required. On vehicles equipped with hydro-boost power brakes, it could also result in loss of power brake assist and increased braking effort would be required. If the power steering fluid spray were to spray onto hot engine parts, an engine compartment fire could occur.

What Will Be Done: Your GM dealer will inspect the power steering hose(s) for two suspect date codes and replace them if required. This service will be performed for you at **no charge**.

How Long Will The Repair Take? This inspection and service correction will take approximately 15 minutes to 2-1/2 hours, depending on your vehicle model. However, due to service scheduling requirements, your dealer may need your vehicle for a longer period of time.

Contacting Your Dealer: To limit any possible inconvenience, we recommend that you contact your dealer as soon as possible to schedule an appointment for this repair. By scheduling an appointment, your dealer can ensure that the necessary parts will be available on your scheduled appointment date. Should your dealer be unable to schedule a service date within a reasonable time, you should contact the appropriate Customer Assistance Center at the listed number below. The Customer Assistance Center's hours of operation are from 8:00 AM to 11:00 PM, EST, Monday through Friday.

Division	Number	Text Telephones (TTY)
Buick	1-866-608-8080	1-800-832-8425
Cadillac	1-866-982-2339	1-800-833-2622
Chevrolet	1-800-630-2438	1-800-833-2438
GMC	1-866-996-9463	1-800-462-8583
Hummer	1-866-964-8663	
Guam	1-671-648-8650	
Puerto Rico – English	1-800-496-9992	
Puerto Rico – Español	1-800-496-9993	
Virgin Islands	1-800-496-9994	

If, after contacting the appropriate Customer Assistance Center, you are still not satisfied that we have done our best to remedy this condition without charge and within a reasonable time, you may wish to write the Administrator, National Highway Traffic Safety Administration, 400

Seventh Street, SW, Washington, DC 40990; or call the toll-free Vehicle Safety Hotline at 1-888-327-4236 (TTY: 1-800-424-9153); or go to <http://www.safercar.gov>.

Customer Reply Form: The enclosed customer reply form identifies your vehicle. Presentation of this form to your dealer will assist in making the necessary correction in the shortest possible time. If you no longer own this vehicle, please let us know by completing the form and mailing it back to us.

Courtesy Transportation: If your vehicle is within the New Vehicle Limited Warranty your dealer may provide you with shuttle service or some other form of courtesy transportation while your vehicle is at the dealership for this repair. Please refer to your Owner's Manual and your dealer for details on Courtesy Transportation.

Recall Information Online: More information about this recall, including answers to frequently asked questions, can be found at the Owner Center at My GMLink. This free online service offers vehicle and ownership related information along with tools tailored to your specific vehicle. To join, visit www.gm.com/recall and enter your vehicle's 17-character vehicle identification number (VIN), shown on the enclosed customer reply form.

Federal regulation requires that any vehicle lessor receiving this recall notice must forward a copy of this notice to the lessee within ten days.

We are sorry to cause you this inconvenience; however, we have taken this action in the interest of your safety and continued satisfaction with our products.

General Motors Corporation

Enclosure
05086