



Land Rover North America, Inc.

# SERVICE BULLETIN

CIRCULATION:			
Dealer Principal	X	Sales Guide	X
Centre Manager	X	Parts Professional	X
Sales Manager	X	Warranty Admin	X
Business Manager	X	Service Advisor	X
Parts Manager	X	Technician	X
Service Manager	X		

Bulletin: SRE06-07

Section: Recall

Date: 20 December 2006

Model: LR3

Applicable to: USA/CDA

Page: 1 of 7

Attachment P001 Repair Procedure

**Subject: Recall P001 – Quarantine Notification for Affected Vehicles  
Fuel Tank Replacement**

*This Recall is an extension of the Recall B016 VIN range into the 2006 Model Year. It also includes a relatively small number of repaired vehicles in the B016 vehicle population that will require a new tank. The affected vehicles were built or repaired with an "interim" tank configuration that now requires replacement. The new Recall number has been utilized to clearly track and identify all vehicles involved in this expansion of the original B016 Recall. The P0001 repair procedure is the same as the previously issued Recall B016 and covers the following vehicle populations:*

- *Specific 2005 Model Year LR3 vehicles within the VIN ranges 5A000360 to 5A342827 that may have been repaired using an interim specification tank.*
- *2005 and 2006 vehicles not previously repaired with the latest specification tank and built within the VIN range 5A342834 to 6A359153 are affected by the defect prompting this Safety Recall.*

## Vehicle Quarantine Notice

*Land Rover North America has informed the National Highway Transportation Safety Administration (NHTSA) and Transport Canada (TC) of its intent to perform a voluntary Safety Recall on a range of 2005 and 2006 LR3 vehicles imported into the United States and Canadian markets. Information relating to the proposed Recall will be posted on the NHTSA and TC web sites. The Recall action will require replacement of fuel tanks on all affected vehicles.*

*U.S. Federal regulations require that Retailers must be advised of this Recall notification within three working days after government notification. Once notified, Retailers must abide by the regulation that new vehicles in Retailer inventory be HELD and not delivered to customers until they can be repaired as described in the Recall Repair Procedure in [Attachment 1](#).*

***U.S. Federal law requires Retailers to complete any outstanding safety Recall service before a new vehicle is delivered to the buyer or lessee. Violation of this requirement by a Retailer could result in a civil penalty of up to \$6,000 per vehicle.***

*This Quarantine notice serves as notification to all Land Rover Retailers in the United States and Canada that affected vehicles may not be delivered for customer use until the Recall repair is completed. Refer to Attachment 1 for repair instructions for vehicles affected by this quarantine.*

*A limited number of affected vehicles are shown by Land Rover records to remain in Retailer inventory. These specific vehicles are the primary objective of this Quarantine. Refer to the following table for a listing of these vehicles.*

Chassis Number	Current Dealer	Chassis Number	Current Dealer	Chassis Number	Current Dealer	Chassis Number	Current Dealer
6A351900	101	6A351021	148	6A358609	251	6A351605	296
6A354354	101	6A358713	163	6A351548	252	6A356673	296
6A355520	101	6A353493	174	6A351600	252	6A357284	304
6A351323	116	6A353787	174	6A352567	255	6A356953	313
6A357797	116	6A350575	182	6A353745	258	6A352388	319
6A353001	128	6A353495	192	6A354764	258	6A352340	320
6A354687	128	6A358425	192	6A358691	265	6A350420	321
6A357419	128	6A345761	206	6A357938	270	6A356191	321
6A348004	136	6A358010	218	6A351267	273	5A345660	324
6A350596	136	6A358841	220	6A353631	273	6A354947	338
6A359141	136	6A357342	229	6A351272	284	6A351107	355
6A351001	148	6A359035	229	6A356828	292	6A349442	357
		6A357228	232	6A351405	296	6A353532	519

## Recall P001: Fuel tank – Leak from Vapor Recovery System

### Situation

A concern has been identified with a vapor recovery system component in the fuel tank on LR3 vehicles. A breather pipe located inside the fuel tank can become detached allowing fuel to enter the breather system. The vehicle may exhibit check engine light illumination, fuel odor and drivability concerns such as hesitation, misfire, stalling, rough running or difficulty in starting. In extreme conditions a fuel spill from the charcoal canister at the rear of the vehicle can occur. Liquid fuel, in the presence of an ignition source, could result in a fire.

Replacement gas tanks for these vehicles are available for Retailer inventory vehicles. Owner notifications will start in late January as parts supply permits.

### Action to be taken

You are required by U.S. law to Quarantine all affected new vehicles in your control.

Sold vehicles will be subject to the standard Recall notification and Recall bulletin process detailing the action required for vehicles in the hands of customers. These documents will be published following standard procedures in the near future.

Retailers are advised that the use of vehicles within the affected VIN range as demonstrators or loaner vehicles may be considered a violation of Federal legislation. Land Rover recommends against using affected vehicles for demonstrator or loaner purposes. Please consult your own legal counsel if you have questions in this regard.

### Customer Inquiries

In the interim, if you are approached by a customer with questions about this Recall, but the customer has not yet received any formal notification, please inform them that Land Rover will notify them in writing if their vehicle is affected by a campaign.

If a United States customer requires additional information concerning this matter, please direct them to contact the Land Rover Customer Relationship Center at 1 800 637 6837

Canadian customers requiring additional information should be directed to the Canadian Customer Relationship Center at 1 800 346 3493.

Thank you for your co-operation in this matter. .



Attachment 1

P001 – Repair Procedure

SECTION: 310-01B

RECALL: Fuel Tank Replacement

AFFECTED VEHICLE RANGE:

Land Rover LR3 (LA)

VIN: 5A000360 to 5A342827 – Specific Vehicles
5A342834 to 6A359153 – Specific Vehicles\*

\* Some vehicles in this range may have been previously repaired under warranty using the latest specification tanks for symptoms relating to this Recall action. Repaired vehicles will be removed from the population when activated on DDW.

CONDITION SUMMARY:

DISCONNECTED VAPOR RECOVERY SYSTEM TUBE POSES RISK FOR FUEL LEAK

Situation: Land Rover has decided to recall all affected vehicles in the VIN ranges to install a replacement fuel tank. Under certain circumstances a fuel tank internal breather tube can become disconnected. When the fuel level in the tank is above the level of the detached joint, fuel may then enter the breather tube. The vehicle may exhibit Check Engine (MIL) symbol illumination, fuel odor, and drivability concerns such as hesitation, misfire, stalling, rough running or difficulty in starting. If the amount of fuel flowing into the breather tube reaches the vapor canister and exceeds its capacity, the excess fuel may be discharged onto the ground. Liquid fuel, in the presence of an ignition source could result in a fire.

Action: Under the provisions of this Recall action the fuel tank assembly will be replaced.

PARTS:

WHK500220 .....Fuel Tank Qty 1

NOTE: Removed tanks must be safely disposed of following local regulations and established Land Rover policy. Your Aftersales Market Managers (AMM) has been provided with further details on disposal cost reimbursement procedures incurred because of local legislation or high volume. Contact your AMM for additional information.

WARRANTY:

Warranty claims should be submitted quoting program code P001 together with the appropriate option code. As option codes are used, there is no requirement to enter parts or labor. They are provided for information only.

Drive in/drive out can only be claimed if the vehicle is brought back into the workshop for this action alone to be undertaken.

Table with 9 columns: Program Code, Option, Job Description, SRO, Time (Hours), Part Number, Part Description, QTY, Misc Expense. It contains two rows of repair data for P001.

Warranty claims should be submitted in accordance with the current Land Rover Warranty Policy and Procedures Manual and its amendments unless stated otherwise in this Recall Action.



# Attachment 1 P001 – Repair Procedure

## REPAIR PROCEDURE

### REMOVE FUEL TANK



**NOTE:** GTR lookup sequence is as follows:

GTR Home > NAS > Service Information/ LA LR3/2005 > Workshop Manuals > Discovery 3 / LR3 2005 Workshop Manual > Open Bookmarks "Powertrain/Fuel System/310-01B: Fuel Tank and Lines - 4.4L" > Link "Fuel Tank (19.55.01)"



**WARNING:** Always observe Workshop Manual procedures, Warning and Cautions when working with gasoline systems on the vehicle.

- The vehicle must be placed in a well-ventilated, quarantined area. 'No Smoking/Gasoline Fumes' signs should be displayed about the vehicle.
  - Cellular phones pose the risk of person injury when used in the vicinity of any fuel related components. Highly flammable vapors are always present and may ignite.
  - Smoking or carrying lighted tobacco or open flame of any type when working on or near any fuel related components could result in personal injury. Highly flammable vapors are always present and may ignite.
  - The spilling of fuel is unavoidable during this operation. All necessary precautions must be taken to prevent fire and explosion.
  - Before disconnecting or removing components, the area around the joint faces and connections must be clean. Open connections must be plugged to prevent contamination.
1. Disconnect the battery ground cable.
  2. Drain the fuel tank contents into a clean fuel caddy for future refill.



**WARNING:** Always support the vehicle on safety stands when working under it.

3. Raise and support the vehicle.
4. Remove the three bolts and two nuts securing the fuel tank heat shield (Figure 1).

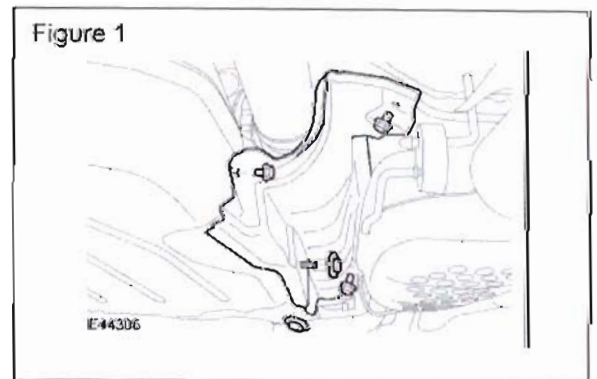



# Attachment 1 P001 – Repair Procedure

**⚠ CAUTION:** Before the disconnection or removal of any components, the area around joint faces and connections must be clean. Open connections should always be plugged to prevent contamination.

5. Disconnect the fuel filler neck from the filler neck hose:
  - Remove the tamper-proof clamp screw cover if fitted.
  - Remove the hose clamp from the filler connector hose. (Figure 2)
6. Disconnect the fuel supply and purge lines quick release connections at the front of the fuel tank. (Figure 3)
7. Disconnect the fuel tank vent line at the rear of the fuel tank, over the integrated body frame. (Figure 4)
8. Release the fuel tank harness.
9. Release the parking brake emergency release cable and the two emergency release cable clips. (Figure 5)

Figure 2

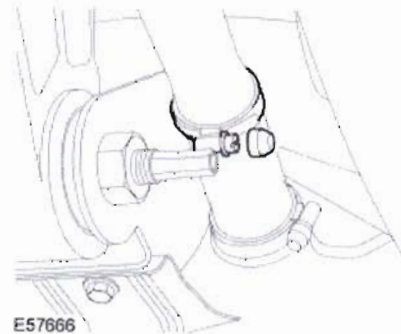

Figure 3



Figure 4



Figure 5

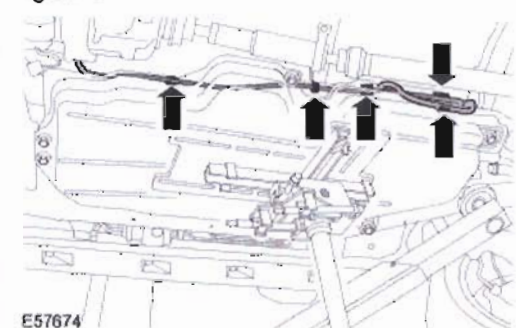



## Attachment 1

# P001 – Repair Procedure

**WARNING:** To ensure stability the fuel tank must be secured to the transmission jack.

**NOTE:** The rear bolt is fitted with 2 washers.

10. Secure the tank to a suitable transmission jack and remove the six fuel tank retaining bolts. (Figure 6)

**CAUTION:** Connectors at the top of the tank permit lowering the fuel tank only 250 mm (9.75 in) in the following step.

11. Lower the fuel tank sufficiently to access the top of the fuel tank – approximately 9 inches.

12. Disconnect the fuel pump module electrical connector. (Figure 7)

13. Release the purge line from the top of the fuel tank (Figure 8):

- Remove the adhesive pad.
- Release from the five clips.

14. Lower the fuel tank.

**CAUTION:** Before the disconnection or removal of any components, ensure the area around joint faces and connections are clean. Plug any open connections to prevent contamination.

15. Remove the fuel tank vent line (Figure 9):

- Disconnect the quick release connector.
- Remove from the 3 clips

16. With assistance, remove the fuel tank from the transmission jack.

Figure 6

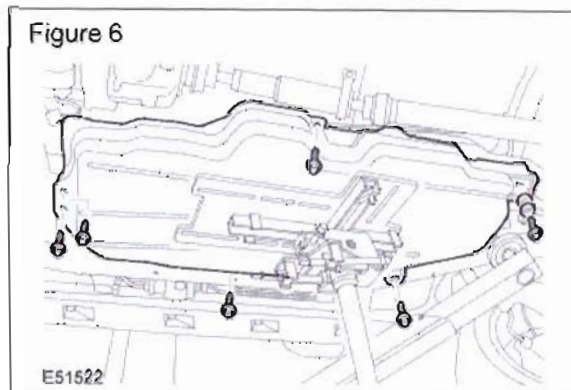

Figure 7

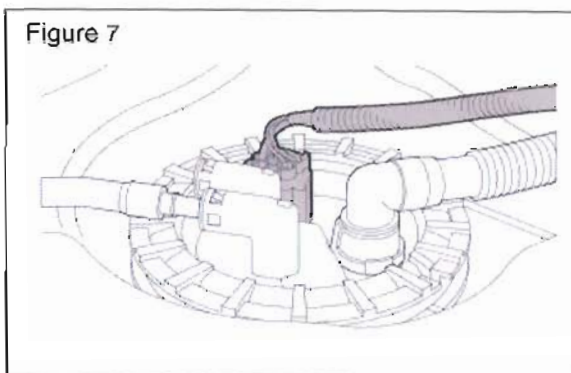

Figure 8

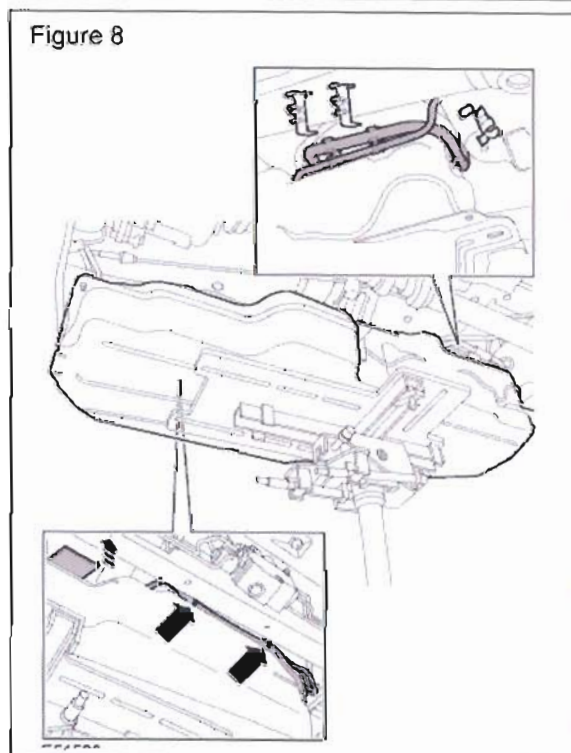
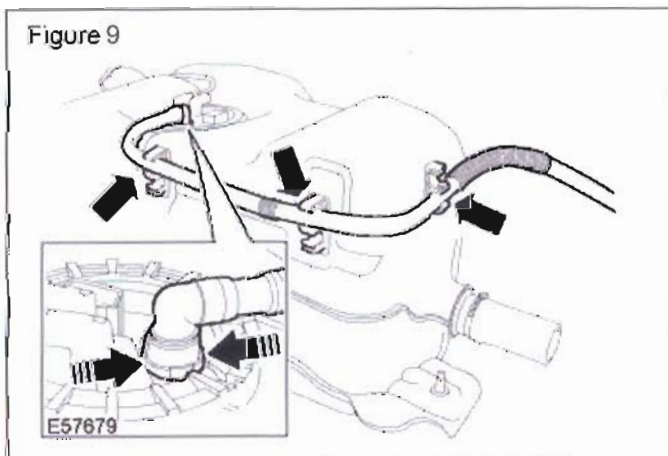

Figure 9





## Attachment 1

# P001 – Repair Procedure

17. Remove the fuel tank bracket (Figure 10):

- Remove the two clips.
- Remove the two bolts.
- Remove the retaining plate.

### INSTALL NEW FUEL TANK WHK500220

1. Install the fuel tank bracket on the new tank assembly:

- Install the retaining plate.
- Install the clips.
- Tighten the bolts to 3.5Nm (2.5 lbf-ft)

2. With assistance, position and secure the replacement fuel tank assembly onto the transmission jack

3. Position the fuel tank under the vehicle, allowing access to the top of the tank.

4. Secure the purge line to the fuel tank:

- Secure with the clips.
- Install the adhesive pad.

5. Connect the electrical connector.



**NOTE:** The rear bolt is fitted with 2 washers.

6. Install the fuel tank and tighten the bolts to 45Nm (33 lbf-ft).

7. Install the two emergency release cable clips.

8. Secure the parking brake emergency release cable and secure the four securing clips.

9. Secure the fuel tank electrical harness.

10. Install the vent line as follows:

- Connect the quick release connector.
- Secure into the 3 clips

11. Connect the fuel supply and purge lines

12. Connect the fuel filler neck as follows:

- Position the removed retaining hose clamp over the tank hose.
- Install the hose over the filler pipe.
- Tighten the hose clamp to 3-4Nm (2-3 lbf-ft).

13. Install the fuel tank heat shield as follows:

- Position the shield to the tank.
- Tighten the bolts to 5 Nm (4 lbf-ft).
- Tighten the nuts to 3 Nm (2 lbf-ft).

14. Refill the fuel tank with removed gasoline.

15. Check for security of fuel, purge and vent lines.

16. Connect battery ground cable.

17. Start and run the engine for a minimum of two minutes.

