



VOLUME

3

GROUP
Campaign

NUMBER
052

MODEL
Sorento

DATE
September 2005

TECHNICAL SERVICE BULLETIN

SUBJECT:
RECALL CAMPAIGN: 2003 SORENTO FUEL LINE REPLACEMENT

This bulletin provides information relating to replacement of fuel lines at the fuel tank assembly. Some 2003MY Sorento vehicles produced between 6/7/02 ~ 8/14/02 may experience a fuel leak near the fuel tank because the fuel line is rubbing against the body and frame. Kia is replacing sections of the fuel lines on all affected vehicles within the production range.

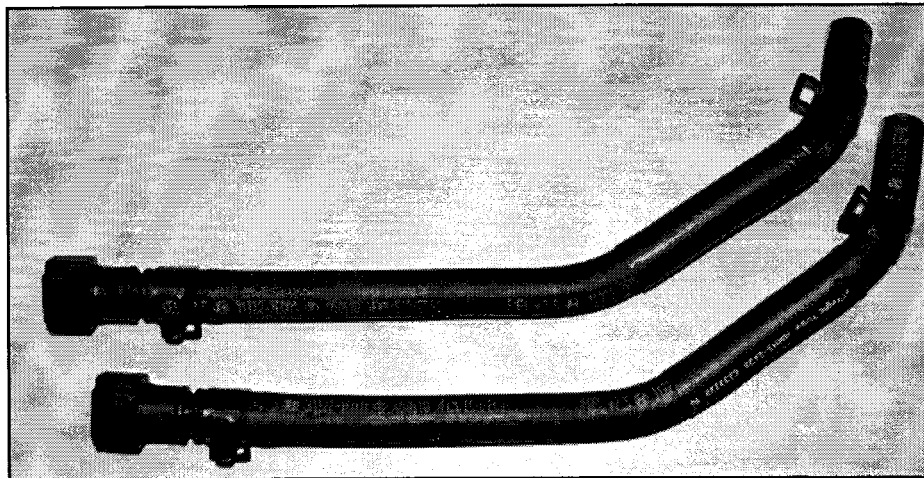

Fuel Hose — (P/N: Q3132 23E000Q Consists of One [1] Fuel Hose) - Two (2) Required Per Vehicle

DANGER

Fuel vapors are flammable. Death or serious injury could result if they are ignited. Make sure there are no open flames or smoking in the area of the repair. Adequate ventilation is necessary to prevent a buildup of fumes which could ignite, causing fire or explosion.

* NOTICE

There is no charge to the vehicle owner for this repair. Under applicable law, you may not sell or otherwise deliver any affected 2003 Sorento until it has been repaired, pursuant to the procedures set forth in this bulletin.

DEFECT INVESTIGATION
2005-09-15
P 3:47

File Under: Campaign

- Circulate To: General Manager Service Manager Parts Manager
 Service Advisor(s) Technician(s) Body Shop Manager Fleet Repair

SUBJECT:

RECALL CAMPAIGN: 2003 SORENTO FUEL LINE REPLACEMENT

INSPECTION PROCEDURE:

1. Open hood and check for SC052 Campaign Completion Label on inner fender above underhood fuse box.
 - If label exists, Campaign SC052 has been completed - NO FURTHER ACTION IS REQUIRED.
 - If Campaign SC052 label DOES NOT EXIST, continue on to FUEL LINE REPLACEMENT.

Note: Campaign completion must be verified on the Warranty Coverage Validation Inquiry screen, prior to performing repairs (Kia Standard System [KSS] Main Menu-Option 3).



FUEL LINE REPLACEMENT:

1. Remove the fuel filler cap and pull fuel pump relay from the underhood fuse box, start the engine and allow it to run until the engine stalls. This will decrease the fuel system pressure in the fuel lines for removal. Turn off ignition, replace the fuel pump relay and fuse box cover.
2. Lift the right rear seat bottom to gain access to the fuel pump module. Remove access cover and disconnect the electrical connectors. Place a shop rag under the fuel line connections before removing them to prevent fuel from spilling onto the top of the fuel tank. Depress the fuel line lock and remove the fuel lines from the fuel pump assembly.

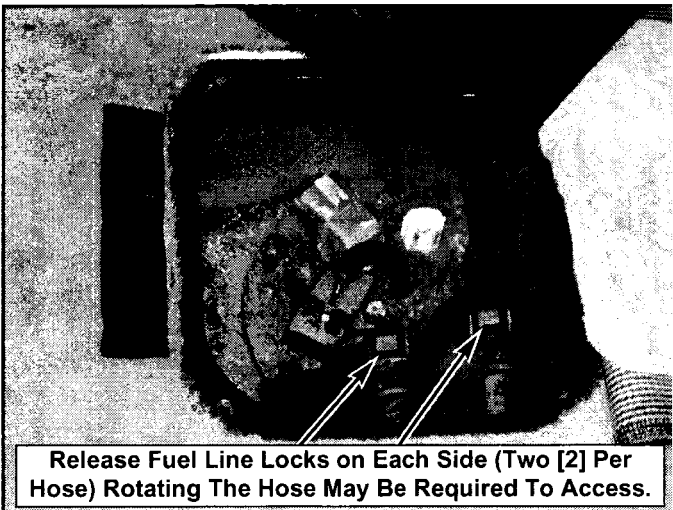
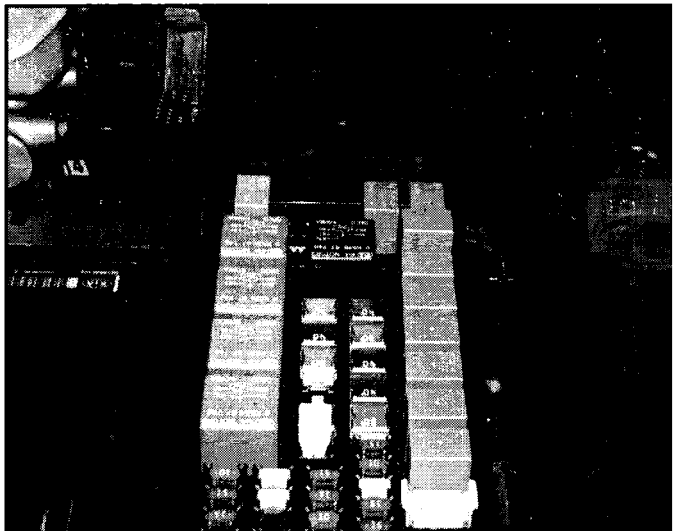

SUBJECT:

RECALL CAMPAIGN: 2003 SORENTO FUEL LINE REPLACEMENT**⚠ DANGER**

Fuel vapors are flammable. Death or serious injury could result if they are ignited. Make sure there are no open flames or smoking in the area of the repair. Adequate ventilation is necessary to prevent a buildup of fumes which could ignite, causing fire or explosion.

3. Raise and properly support the vehicle as required. Remove right rear wheel and tire assembly.
4. Remove the inner fender well shield from the right rear wheel well to access the fuel lines.
5. Disconnect the fuel filler hose from the fuel filler pipe. Tuck the filler hose into the tank area to gain access to the fuel lines, as shown.

Note: Do not allow dirt to enter the filler hose.

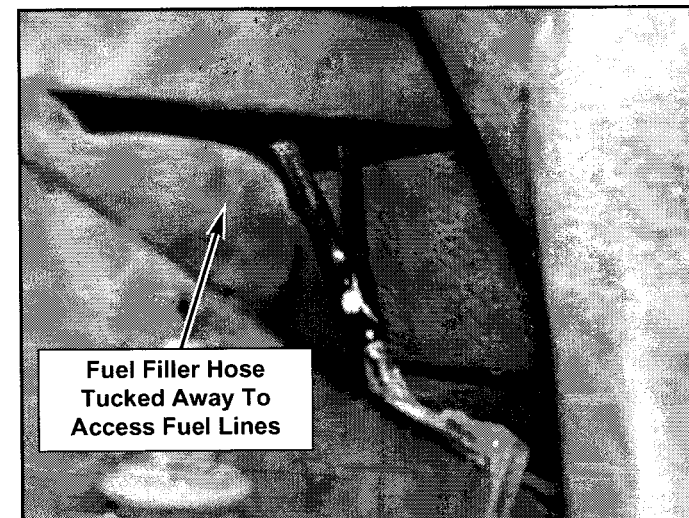
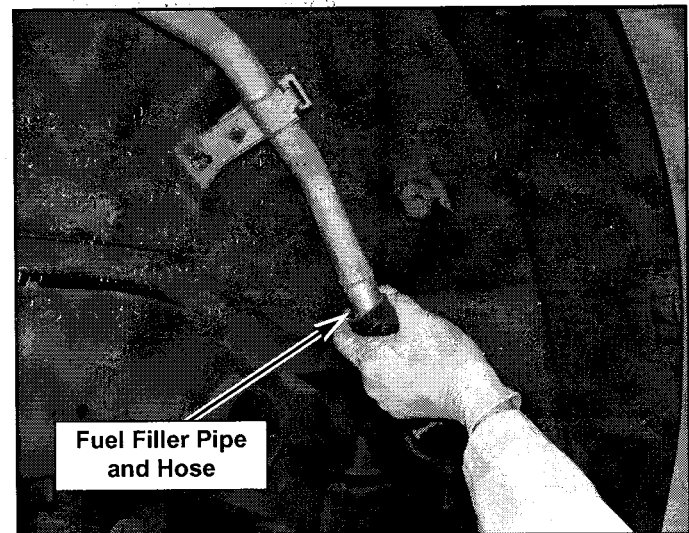

SUBJECT:

RECALL CAMPAIGN: 2003 SORENTO FUEL LINE REPLACEMENT

6. Using a utility knife or suitable tool, carefully cut the plastic fuel line off the steel line on both pressure and return fuel lines.

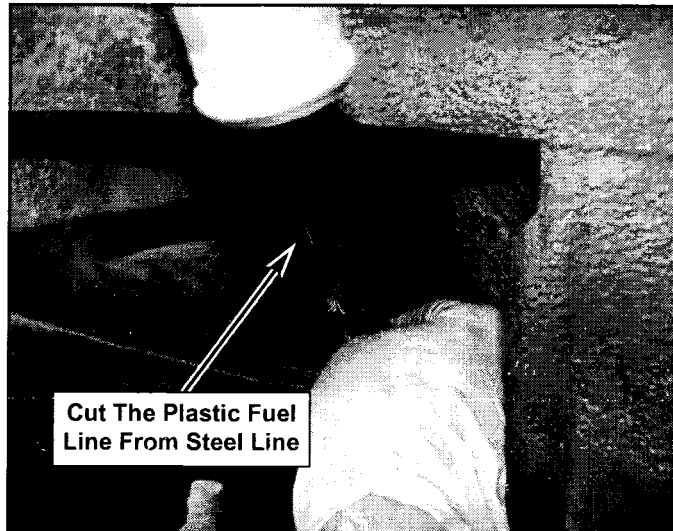

INSTALLATION PROCEDURE:

1. Install the new rubber fuel lines on the steel lines. Ensure that the routing of the fuel lines is correct and that they are not crossed. Install the fuel line hose spring clamps.

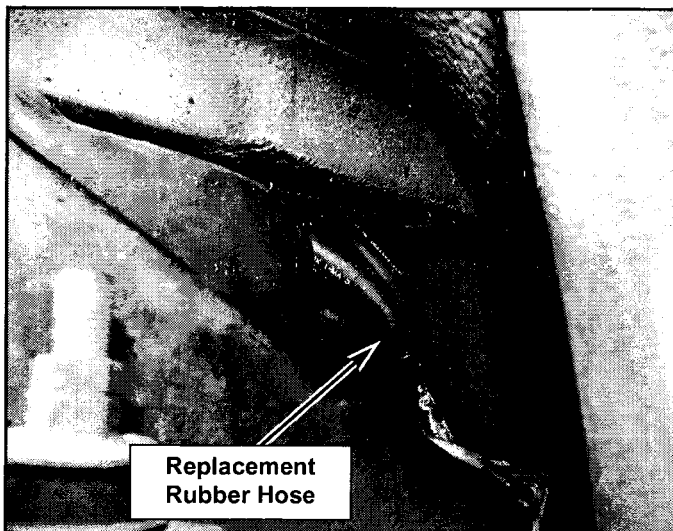

2. Connect the rubber fuel filler hose to the steel filler neck, install and tighten hose clamps.



SUBJECT:

RECALL CAMPAIGN: 2003 SORENTO FUEL LINE REPLACEMENT

- Lower the vehicle, install the fuel lines to the fuel pump module.

*** NOTICE**

With other end of lines properly installed and not crossed, supply and return lines should be facing the correct connection points on the pump.

Connect the electrical connectors to the fuel pump module.

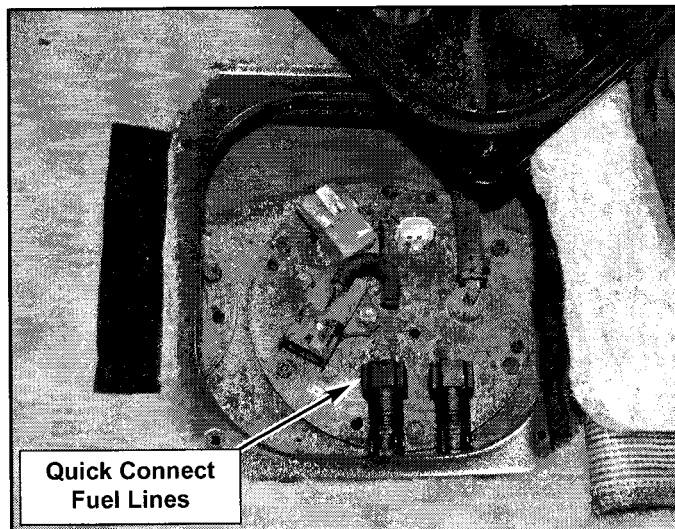

- Start the engine, let it run for 15 seconds and turn the ignition key to the OFF position. Check for fuel leaks, if any are found, repair as necessary.
- Install the fuel pump access cover. Lower the rear seat as required.
- Install the inner wheel guard.

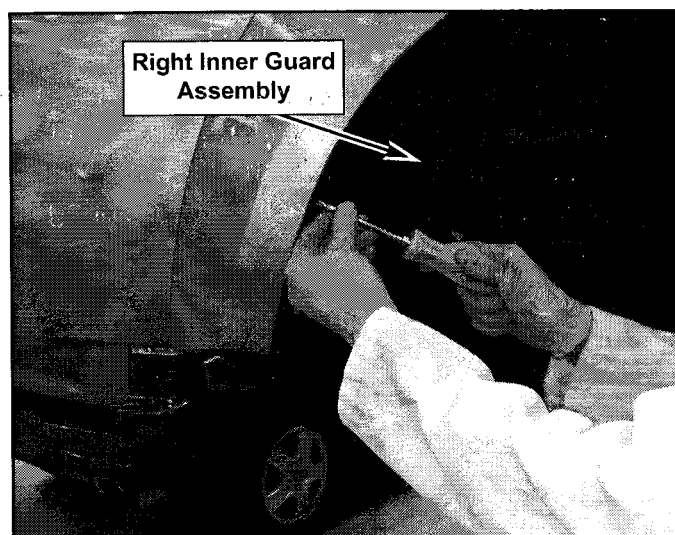

- Install wheel and tire assembly, snug nuts first, then tighten the wheel nuts to 65~86 lb ft. (90~120 Nm) in correct sequence (see illustration).

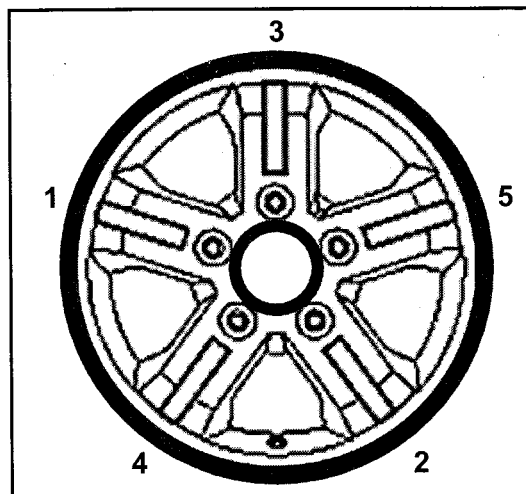

SUBJECT
RECALL CAMPAIGN: 2003 SORENTO FUEL LINE REPLACEMENT

- 8. Install the fuel filler cap and attach the SC052 Campaign Completion Label to the inner fender above underhood fuse box.

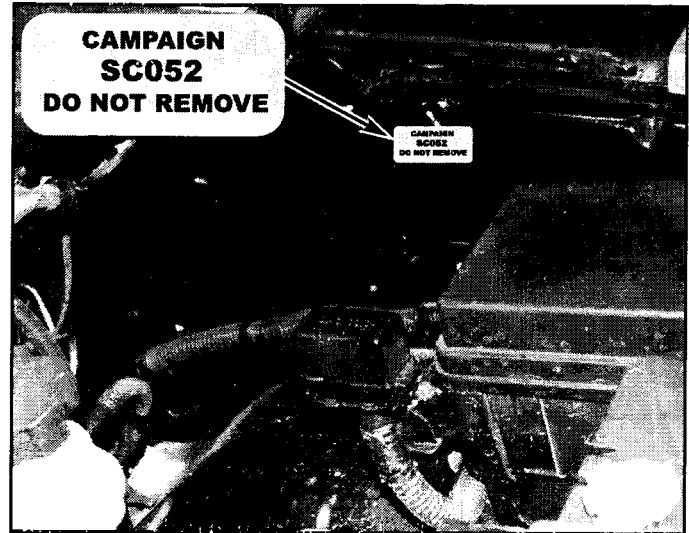

AFFECTED PRODUCTION RANGE:

2003 Sorento vehicles with production dates from 6/7/02 through 8/14/02.

PART NUMBER INFORMATION:

Description	P/N
Hose assy - Fuel	Q3132 23E000Q *
SC052 Campaign Completion Label	UB050 SC052
SC052 Proof of Correction Card	UB051 SC052

Extra SC052 Campaign Completion Labels and/or Proof of Correction Cards are available at no cost through your regional PDC.

*** Two (2) fuel hoses are required per vehicle.**

WARRANTY CLAIM INFORMATION:

Claim Type	Causal P/N	Qty.	Cond. Code	Cause Code	Repair Description	Labor OP Code	Time	Related Parts	Qty.
R	31280 3E200	0	N99	C24	Replacement of Fuel Hoses	051034R1	0.6	Q31322 3E000Q	2

To improve customer satisfaction always remember to refer to the Warranty Coverage Validations Inquiry Screen (Select 3) on your Kia Standard System (KSS) Dealer Main Menu for a list of any additional campaigns that may need to be performed on the vehicle before returning it to the customer.

SUBJECT:

RECALL CAMPAIGN: 2003 SORENTO FUEL LINE REPLACEMENT

FOR CALIFORNIA, MASSACHUSETTS, VERMONT, AND MAINE DEALERS:

VEHICLE EMISSION RECALL - PROOF OF CORRECTION CARD

A Vehicle Emission Recall - Proof of Correction card **must be** filled out for all vehicles registered in California, Massachusetts, Vermont, and Maine.

California, Massachusetts, Vermont, and Maine residents who own an affected vehicle will be required to possess a **Vehicle Emission Recall - Proof of Correction** card as evidence of voluntary service campaign completion when they apply for vehicle registration renewal.

WHAT TO DO WITH THE CARD:

Each customer whose vehicle is registered in California, Massachusetts, Vermont, and Maine must be **given** a completed **Vehicle Emission Recall - Proof of Correction** card after the voluntary service campaign has been completed.

Note: This card MUST be completed by the Dealership's Service Manager using a permanent ink pen. A fine point pen is recommended. When filling in the information, copy the information directly from the vehicle, NOT the repair order. ALL INFORMATION MUST BE PRINTED AND NEAT.

DO NOT COMPLETE THE CARD UNLESS THE VOLUNTARY SERVICE CAMPAIGN WORK IS COMPLETED!

The copy of the card shown below indicates the areas to be filled in. Each area must be filled in.

Vehicle Emission Recall —Proof of Correction

Enter Vehicle's License Number Enter Kia Enter Vehicle's Model Year Enter Vehicle's Model Name (i.e. Rio) Enter Vehicle's VIN No.

License Number Make Year Model Body Type Vehicle Identification Number

Manufacturer: Kia Motors America, Inc. Recall Number: SC052

The above described vehicle has been repaired, modified and/or equipped with new emission control devices to meet applicable California Emission Control Laws and for vehicles sold in Massachusetts, Vermont and Maine.

Dealers Name Address, City, State and Zip

Date Dealership Authorized Signature

X

Return this certificate to DMV only when required — otherwise retain for your records.

Enter Dealership's Name Enter Date of Repair Sign Here Enter Dealership's Physical Address (NOT Mailing Address)