



VEHICLE RECALL

SC300

(Not applicable to Mack Trucks Australia)

Date: 09/13/05 (Supersedes SC300 dated 08/12/05)

To: All MACK Dealers

Subject: Holland AD-123, AD-246 and AD-369 Series Air Suspension Transverse Beams — CV, CX, CL and MR Models (23,000 lb. Single Axles, 46,000 lb. Tandem Axles and 69,000 lb. Tri-Axle Suspensions)

Information:

The Holland Group, Inc., manufacturer of heavy-duty truck suspensions, has determined that a safety defect exists with certain AD-123, AD-246 and AD-369 Air-Ride Suspensions used in MACK CX, CV, CL and MR model chassis manufactured between January 2004 and January 2005. Holland® AD Series Suspensions involved in this campaign were produced with transverse beams (T-beams) manufactured with end castings that do not conform to Holland® material specifications. As a result, the end castings can fracture and fail under normal loads, resulting in casting fragments being thrown from the moving vehicle or the T-beam dropping down and contacting the road surface, with the potential for creating sparks and a resultant fire. Approximately 115 CX, CV, CL and MR models manufactured between January 12, 2004 and January 31, 2005 and equipped with Holland® AD123, AD-246 and AD-369 air suspensions are involved in this campaign. A list of affected vehicles has been sent to all applicable dealers.

Procedures:

The transverse beams on all affected chassis must be replaced.

NOTE

Before proceeding, check the campaign status in the MACKnet system to see if the campaign has already been completed. Campaign status can also be checked by looking at the Campaign Completion Label located on the lower edge of the passenger-side door. If the campaign has been completed, the campaign number (SC300) and the completion date should be written on the label.

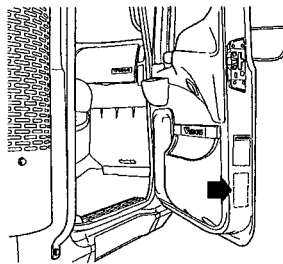

703153a

Figure 1 — Campaign Label Location

SC300 — Page 1 of 9

Procedures for replacing the transverse beams are as follows:

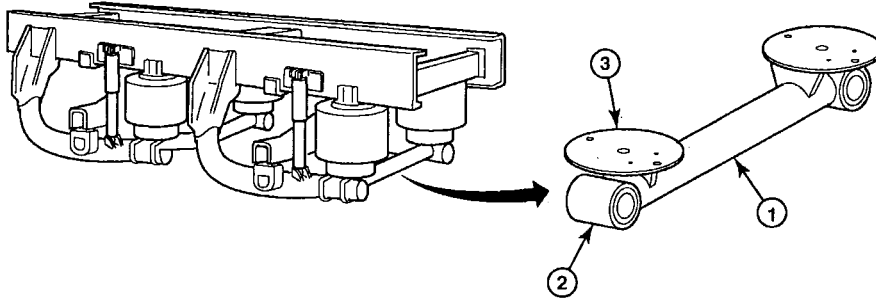

101710a

Figure 2 — Holland® AD Series Air Suspension

1. Transverse Beam (T-Beam)	3. Lower Air Spring Mounting Plates
2. End Castings	

Before proceeding, consult the chassis build records to determine the suspension model so that the correct T-beam replacement kits can be obtained. Suspension models AD-123, AD-246 and AD-369 use T-beam replacement kit part No. 48100436. The replacement kit contains the proper T-beam and the associated mounting hardware (locking spacer assemblies, tab washers and large hex nuts).

1. Secure the chassis for service, block the wheels to prevent the vehicle from moving and apply the parking brakes.

NOTE

It is recommended that the vehicle be unloaded and the wheels properly blocked before proceeding with replacing the T-beam. Also, be sure there is adequate clearance underneath the vehicle to perform the procedure.

2. Clean the pin shafts and the T-beam fasteners prior to disassembly to protect the pin shaft threads.

3. Clean the space between the pin shaft and the large hex nut on both sides of the vehicle to remove dirt and debris. A piece of wire can be used to help loosen trapped debris.

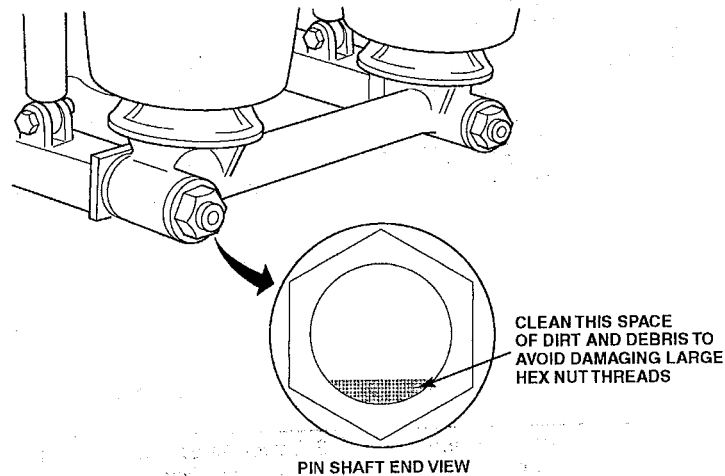

101708a

Figure 3 — Clean Space Between Pin Shaft and Large Hex Nut

⚠ WARNING

Always wear safety glasses when working on the suspension to avoid the possibility of eye injury.

4. Raise the frame 2" (50.8 mm) above normal ride height and support with jackstands of adequate capacity.

⚠ DANGER

Always use jackstands of adequate capacity to support the weight of the vehicle. Failure to do so can allow the vehicle to fall, resulting in severe personal injury.

NOTE

The height control valves can be used to raise the chassis the specified amount.

5. Using the manual dump valve (if so equipped), exhaust the air from the air springs, and then completely drain the air system. If the vehicle is not equipped with a manual dump valve, the height control valve can be used to exhaust the air springs by disconnecting the linkage from the valve(s), and then rotate the control arm down to the exhaust position.

- With the air springs deflated, remove the air springs from the lower air spring mounting plates on both sides of the vehicle by removing the nut and washer located under the mounting plates. Retain the hardware for reinstallation. Also, disconnect the height control valve(s) linkage(s) from the tabs located on the top of the T-beam.

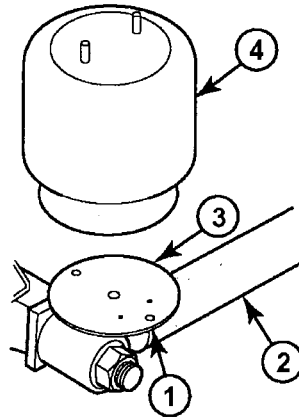

101709a

Figure 4 — Remove Air Springs

1. Nut/Washer Location	3. Lower Mounting Plate
2. T-Beam	4. Air Spring

- After disconnecting the air springs from the lower mounting plates, remove the large hex nuts, tab washers and locking spacers from the pin shafts located at the end of each equalizing beam on both sides of the vehicle.

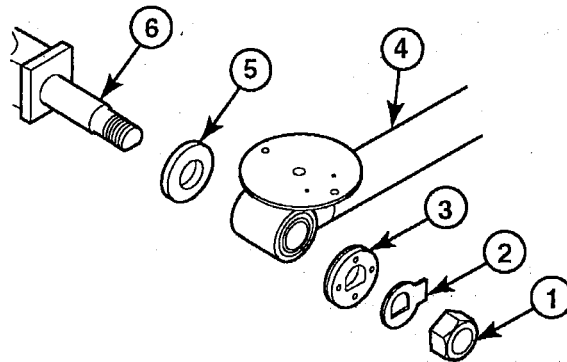

101707a

Figure 5 — Transverse Beam Disassembly

1. Large Hex Nut	4. T-Beam
2. Tab Washer	5. Spacer Washer
3. Locking Spacer	6. Pin Shaft

- Slide the T-beam off the pin shafts. Note the orientation of the linkage tabs welded to the top of the T-beam (either facing forward or rearward, refer to figure below). If the height control valve(s) linkage(s) were connected to these tabs, the tabs must be oriented in the same position when the replacement T-beam is installed.

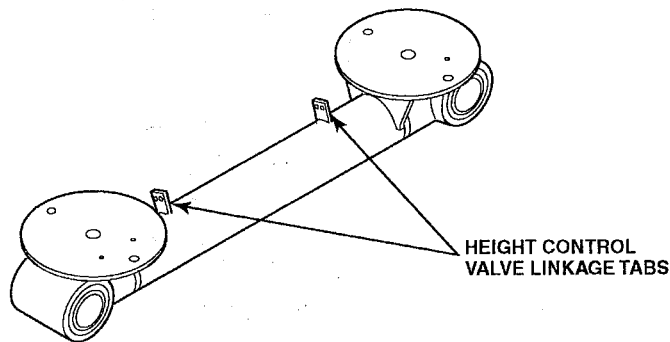

101706a

Figure 6 — T-Beam Height Control Valve Linkage Tabs

- Clean the exposed portions of the pin shafts to remove any rust, dirt and debris. If the bushings remained on the pin shafts, use a screwdriver or small chisel to separate the metal bushing sleeve to facilitate removal. The bushing is a split design for this purpose.

NOTE

Be sure to retain the large spacer washers located on the pin shafts behind the T-beam ends. These washers will be used when the replacement T-beam is installed.

NOTE

The pin shafts and pin shaft threads are coated with Dacromet® during the manufacturing process. Dacromet® is a hard, silver-colored coating that protects the pin shafts from rust. Pin shafts may also be painted. The paint serves no purpose, and is of no concern if the paint is chipped, cracked or removed. The Dacromet® coating serves as the primary protection for the pin shaft.

- After cleaning the pin shafts, install the spacer washers over each shaft.

11. Install the replacement T-beam onto the pin shafts.

NOTE

The replacement T-beam already has new bushings pressed into the ends.

Be sure to orient the height control valve linkage tabs in the proper position when installing the T-beam.

NOTE

Do not discard the box in which the replacement T-beam was received. This box will be used to return the removed T-beam to the Holland Group.

12. Install the new locking spacer assemblies and tab washers over the pin shafts. After ensuring that the pin shaft threads are clean, install the large hex nuts. Install the hex nuts dry, do not lubricate. The Dacromet® coating reduces frictional drag. Using an accurately calibrated torque wrench, tighten the large hex nuts to 550 lb-ft (745 N•m).

NOTE

Do not use an air impact wrench to apply final torque. An accurately calibrated torque wrench must be used.

13. Bend the tab of the tab washer over the hex nut.
14. Using the existing washers and nuts, reinstall the air springs to the lower mounting plates, and tighten the nuts to 30 lb-ft (40 N•m).

NOTE

If the air spring has more than one mounting stud protruding through the mounting plate, install the washer and nut on the rearmost stud only.

15. Perform the above procedures on the remaining axle(s).
16. Paint the transverse beams.
17. Reconnect the height control valve linkages.
18. Start the engine and allow the air system to build pressure until governor cut-out.
19. After the air system has reached full system pressure, stop the engine and adjust proper ride height.

NOTE

Axle alignment is not necessary.

NOTE

To signify that the campaign has been completed, use a permanent-type marker (such as a Sharpie®) to write the campaign number (SC300) and completion date in the spaces provided on the Campaign Completion label located on the lower edge (below the door latch) of the passenger-side door. If a label is not already affixed to the door, apply a label (part No. TS897) and supply the information as required. Campaign Completion labels are available in packs of 50 and can be ordered by faxing a completed BR313 to Pacesetters Business Services at 610-264-9465.

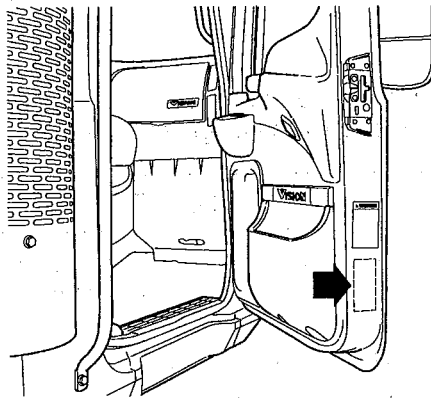

703153a

Figure 7 — Campaign Label Location

Parts Required:

In the U.S., order the replacement kits using the electronic Vendor Direct Ship Program (VDSP) system using the special Holland blanket purchase order No. SMH 3889 99. Kits will be shipped freight prepaid. The blanket purchase order can only be used for the kits involved in this campaign.

REV In Canada, order the replacement kits by using the electronic Vendor Direct Ship Program (VDSP) system using the special Holland blanket purchase order No. CMH388912. Kits will be shipped freight prepaid. The blanket purchase order can only be used for the kits involved in this campaign.

International orders are to be prefixed — V.O.R.

Qty.	Part No.	Description
*	48100436	T-beam replacement kit for Holland® AD-123, AD-246 and AD-369 suspensions (includes transverse beam, two locking spacer assemblies, two tab washers and two large [2-1/4-8] hex nuts)

* Quantity depends upon suspension model. Order one kit for AD-123 suspension, two kits for AD-246 suspension and three kits for AD-369 suspension.

Removed Parts:

The removed T-beams must be returned to the Holland Group, Inc. Shipping is pre-paid, so there is no cost to the dealership. Procedures for returning the T-beams are as follows:

NOTE

Do not discard the boxes in which the replacement T-beams were received. The boxes will be used to return the T-beams to the Holland Group.

1. Remove the red registration tag from the information envelope that was included with the replacement T-beam.

NOTE

For this campaign, eWarranty will not print return shipment labels.

2. Print the requested information in the spaces on the tag, and then firmly attach the tag to the removed T-beam using the wire provided with the tag.
3. Place the tagged T-beam into the box, and then securely tape, staple or strap the box closed.
4. Affix the appropriate return shipment label to the box by removing the paper backing from the label and then placing it over the original shipping label. Use one of the three shipping labels provided in the information envelope as follows:
 - **For return shipments originating in the U.S.**, use the Muskegon, Michigan shipping label.
 - **For return shipments originating in Canada**, there are two shipping labels. Use whichever label for the Canadian return center location (Surrey, BC or Woodstock, Ontario) that is closest to the dealership.
5. Contact Evans Transportation Services at 1-800-886-7799 to arrange for the return shipment. Reference Holland Campaign No. RC321 when making the shipping arrangements with the transportation company. Return shipments are pre-paid by the Holland Group, Inc.

For information or assistance regarding this campaign, contact the Holland Group, Inc. directly between 8 am and 5 pm Eastern Standard Time at the following numbers:

- **For Holland Customer Service** — 1-888-396-6501, extension 8555
- **For Holland Technical Service** — 1-888-396-6501, ask for the Tech Group.

Information regarding this campaign can also be found on the Holland Group, Inc. website at www.thehollandgroupinc.com.

Reimbursement:

Campaign expenses are to be recovered through normal warranty claim procedures. Enter the following information on the warranty claim:

<u>UNDER</u>	<u>ENTER</u>	
Failed Part No.....	SC0300	
Labor Code/Allowance	136 3A KP 95 — 0.2 hr.	Time allowed to take charge of vehicle and determine campaign status by checking the MACKnet system and the campaign completion label.
	136 3B KP 95 — 1.7 hrs.	Time allowed per axle to remove and replace T-beams on chassis involved in this campaign. Includes time to paint replacement beam. Does not include "take-charge" time.

NOTE

As required by Federal Motor Vehicle Safety Standards 49 CFR 573.11, no vehicle subject to an open safety campaign shall be delivered to the customer until such time as the defect or noncompliance is remedied.

05V -312



VEHICLE RECALL

SC301

(Not applicable to Mack Trucks Australia)

Date: 09/13/05 (Supersedes SC301 dated 08/12/05)

To: All MACK Dealers

Subject: Holland AD-252 Series Air Suspension Transverse Beams — CV, CL, RD and MR Models with 52,000 lb. Suspension

Information:

The Holland Group, Inc., manufacturer of heavy-duty truck suspensions, has determined that a safety defect exists with certain AD-252 Air-Ride Suspensions used in MACK CV, CL, MR and RD model chassis having 52,000 lb. suspensions and manufactured between March 4, 2004 and March 18, 2005. Holland® AD Series Suspensions involved in this campaign were produced with transverse beams (T-beams) manufactured with end castings that do not conform to Holland® material specifications. As a result, the end castings can fracture and fail under normal loads, resulting in casting fragments being thrown from the moving vehicle or the T-beam dropping down and contacting the road surface, with the potential for creating sparks and a resultant fire. Approximately 28 CV, CL, MR and RD models equipped with 52,000 lb. rear suspensions and manufactured between March 4, 2004 and March 18, 2005 are involved in this campaign. A list of affected vehicles has been sent to all applicable dealers.

Procedures:

The transverse beams on all affected chassis must be replaced.

NOTE

Before proceeding, check the campaign status in the MACKnet system to see if the campaign has already been completed. Campaign status can also be checked by looking at the Campaign Completion Label located on the lower edge of the passenger-side door. If the campaign has been completed, the campaign number (SC301) and the completion date should be written on the label.

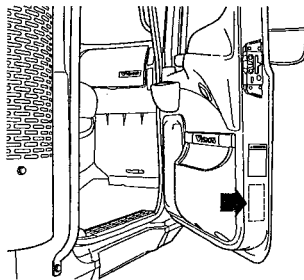

703153a

Figure 1 — Campaign Label Location

SC301 — Page 1 of 9

Procedures for replacing the transverse beams are as follows:

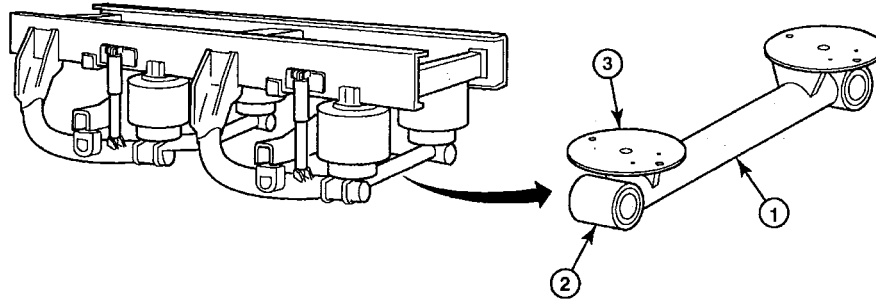

101710a

Figure 2 — Holland® AD Series Air Suspension

1. Transverse Beam (T-Beam)	3. Lower Air Spring Mounting Plates
2. End Castings	

Before proceeding, consult the chassis build records to determine the suspension model so that the correct T-beam replacement kits can be obtained. Suspension model AD-252 uses T-beam replacement kit part No. 48100437. The replacement kit contains the proper T-beam and the associated mounting hardware (locking spacer assemblies, tab washers and large hex nuts).

1. Secure the chassis for service, block the wheels to prevent the vehicle from moving and apply the parking brakes.

NOTE

It is recommended that the vehicle be unloaded and the wheels properly blocked before proceeding with replacing the T-beam. Also, be sure there is adequate clearance underneath the vehicle to perform the procedure.

2. Clean the pin shafts and the T-beam fasteners prior to disassembly to protect the pin shaft threads.

3. Clean the space between the pin shaft and the large hex nut on both sides of the vehicle to remove dirt and debris. A piece of wire can be used to help loosen trapped debris.

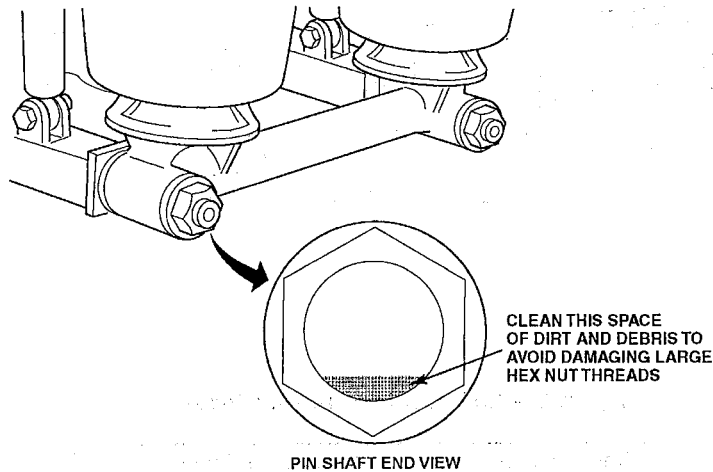

101708a

Figure 3 — Clean Space Between Pin Shaft and Large Hex Nut

⚠ WARNING

Always wear safety glasses when working on the suspension to avoid the possibility of eye injury.

4. Raise the frame 2" (50.8 mm) above normal ride height and support with jackstands of adequate capacity.

⚠ DANGER

Always use jackstands of adequate capacity to support the weight of the vehicle. Failure to do so can allow the vehicle to fall, resulting in severe personal injury.

NOTE

The height control valves can be used to raise the chassis the specified amount.

5. Using the manual dump valve (if so equipped), exhaust the air from the air springs, and then completely drain the air system. If the vehicle is not equipped with a manual dump valve, the height control valve can be used to exhaust the air springs by disconnecting the linkage from the valve(s), and then rotate the control arm down to the exhaust position.

- With the air springs deflated, remove the air springs from the lower air spring mounting plates on both sides of the chassis by removing the nut and washer located under the mounting plates. Retain the hardware for reinstallation. Also, disconnect the height control valve(s) linkage(s) from the tabs located on the top of the T-beam.

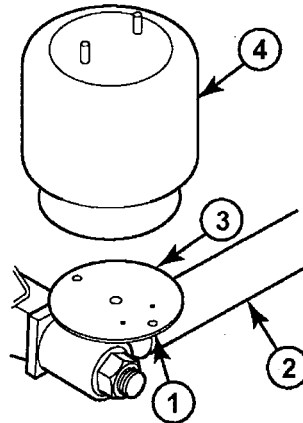

101709a

Figure 4 — Remove Air Springs

1. Nut/Washer Location	3. Lower Mounting Plate
2. T-Beam	4. Air Spring

- After disconnecting the air springs from the lower mounting plates, remove the large hex nuts, tab washers and locking spacers from the pin shafts located at the end of each equalizing beam on both sides of the vehicle.

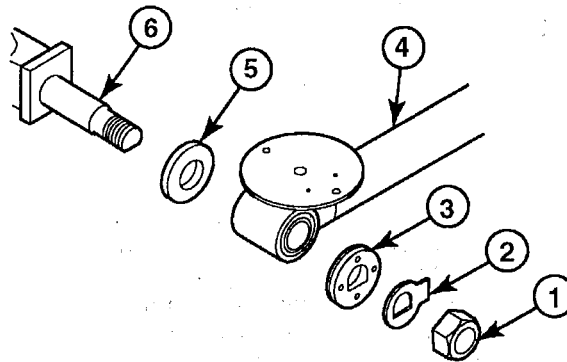

101707a

Figure 5 — Transverse Beam Disassembly

1. Large Hex Nut	4. T-Beam
2. Tab Washer	5. Spacer Washer
3. Locking Spacer	6. Pin Shaft

- Slide the T-beam off the pin shafts. Note the orientation of the linkage tabs welded to the top of the T-beam (either facing forward or rearward, refer to figure below). If the height control valve(s) linkage(s) were connected to these tabs, the tabs must be oriented in the same position when the replacement T-beam is installed.

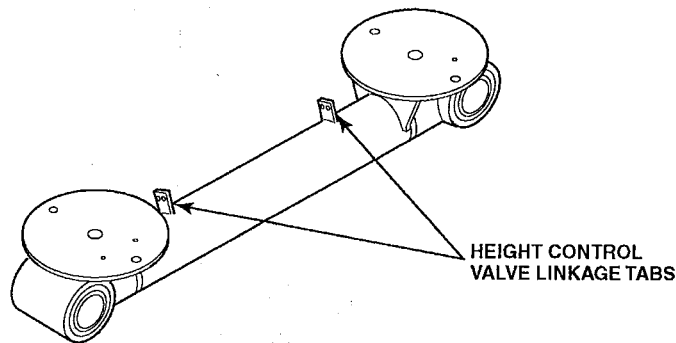

101706a

Figure 6 — T-Beam Height Control Valve Linkage Tabs

- Clean the exposed portions of the pin shafts to remove any rust, dirt and debris. If the bushings remained on the pin shafts, use a screwdriver or small chisel to separate the metal bushing sleeve to facilitate removal. The bushing is a split design for this purpose.

NOTE

Be sure to retain the large spacer washers located on the pin shafts behind the T-beam ends. These washers will be used when the replacement T-beam is installed.

NOTE

The pin shafts and pin shaft threads are coated with Dacromet® during the manufacturing process. Dacromet® is a hard, silver-colored coating that protects the pin shafts from rust. Pin shafts may also be painted. The paint serves no purpose, and is of no concern if the paint is chipped, cracked or removed. The Dacromet® coating serves as the primary protection for the pin shaft.

- After cleaning the pin shafts, install the spacer washers over each shaft.

11. Install the replacement T-beam onto the pin shafts.

NOTE

The replacement T-beam already has new bushings pressed into the ends.

Be sure to orient the height control valve linkage taps in the proper position when installing the T-beam.

NOTE

Do not discard the box in which the replacement T-beam was received. This box will be used to return the removed T-beam to the Holland Group.

12. Install the new locking spacer assemblies and tab washers over the pin shafts. After ensuring that the pin shaft threads are clean, install the large hex nuts. Install the hex nuts dry, do not lubricate. The Dacromet® coating reduces frictional drag. Using an accurately calibrated torque wrench, tighten the large hex nuts to 550 lb-ft (745 N•m).

NOTE

Do not use an air impact wrench to apply final torque. An accurately calibrated torque wrench must be used.

13. Bend the tab of the tab washer over the hex nut.
14. Using the existing washers and nuts, reinstall the air springs to the lower mounting plates, and tighten the nuts to 30 lb-ft (40 N•m).

NOTE

If the air spring has more than one mounting stud protruding through the mounting plate, install the washer and nut on the rearmost stud only.

15. Perform the above procedures on the remaining axle.
16. Reconnect the height control valve linkages.
17. Paint the transverse beams.
18. Start the engine and allow the air system to build pressure until governor cut-out.
19. After the air system has reached full system pressure, stop the engine and adjust proper ride height.

NOTE

Axle alignment is not necessary.

NOTE

To signify that the campaign has been completed, use a permanent-type marker (such as a Sharpie®) to write the campaign number (SC301) and completion date in the spaces provided on the Campaign Completion label located on the lower edge (below the door latch) of the passenger-side door. If a label is not already affixed to the door, apply a label (part No. TS897) and supply the information as required. Campaign Completion labels are available in packs of 50 and can be ordered by faxing a completed BR313 to Pacesetters Business Services at 610-264-9465.

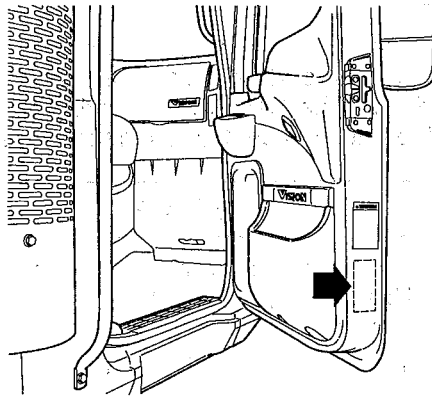

703153a

Figure 7 — Campaign Label Location

Parts Required:

In the U.S., order replacement kits using the electronic Vendor Direct Ship Program (VDSP) system using the special Holland blanket purchase order No. SMH 3889 99. Kits will be shipped freight prepaid. The blanket purchase order can only be used for the kits involved in this campaign.

REV In Canada, order the replacement kits by using the electronic Vendor Direct Ship Program (VDSP) system using the special Holland blanket purchase order No. CMH388912. Kits will be shipped freight prepaid. The blanket purchase order can only be used for the kits involved in this campaign.

International orders are to be prefixed — V.O.R.

Qty.	Part No.	Description
2	48100437	T-beam replacement kit for Holland® AD-252 (52,000 lb. tandem axle) suspension (includes transverse beam, two locking spacer assemblies, two tab washers and two large [2-1/4-8] hex nuts)

Removed Parts:

The removed T-beams must be returned to the Holland Group, Inc. Shipping is pre-paid, so there is no cost to the dealership. Procedures for returning the T-beams are as follows:

NOTE

Do not discard the boxes in which the replacement T-beams were received. The boxes will be used to return the T-beams to the Holland Group.

1. Remove the red registration tag from the information envelope that was included with the replacement T-beam.

NOTE

For this campaign, eWarranty will not print return shipment labels.

2. Print the requested information in the spaces on the tag, and then firmly attach the tag to the removed T-beam using the wire provided with the tag.
3. Place the tagged T-beam into the box, and then securely tape, staple or strap the box closed.
4. Affix the appropriate return shipment label to the box by removing the paper backing from the label and then placing it over the original shipping label. Use one of the three shipping labels provided in the information envelope as follows:
 - **For return shipments originating in the U.S.**, use the Muskegon, Michigan shipping label.
 - **For return shipments originating in Canada**, there are two labels. Use whichever label for the Canadian return center location (Surrey, BC or Woodstock, Ontario) that is closest to the dealership.
5. Contact Evans Transportation Services at 1-800-886-7799 to arrange for the return shipment. Reference Holland Campaign No. RC321 when making the shipping arrangements with the transportation company. Return shipments are pre-paid by the Holland Group, Inc.

For information or assistance regarding this campaign, contact the Holland Group, Inc. directly between 8 am and 5 pm Eastern Standard Time at the following numbers:

- **For Holland Customer Service** — 1-888-396-6501, extension 8555
- **For Holland Technical Service** — 1-888-396-6501, ask for the Tech Group.

Information regarding this campaign can also be found on the Holland Group, Inc. website at www.thehollandgroupinc.com.

Reimbursement:

Campaign expenses are to be recovered through normal warranty claim procedures. Enter the following information on the warranty claim:

UNDER	ENTER	
Failed Part No.....	SC0301	
Labor Code/Allowance	136 3C KP 95 — 0.2 hr.	Time allowed to take charge of vehicle and determine campaign status by checking the MACKnet system and the campaign completion label.
	136 3D KP 95 — 1.7 hrs.	Time allowed per axle to remove and replace T-beams on both front-rear and rear-rear axles. Includes time to paint T-beams. Does not include "take-charge" time.

NOTE

As required by Federal Motor Vehicle Safety Standards 49 CFR 573.11, no vehicle subject to an open safety campaign shall be delivered to the customer until such time as the defect or noncompliance is remedied.