

SERVICE BULLETIN



B-060

May 02, 2005

SAFETY RECALL CODE 0830 - SIDESTAND PIVOT BOLT FOR 2005 FIREBOLT XB12R AND LIGHTNING XB12S, XB9SX

Purpose

Buell Motorcycle Company has decided that there is a potential safety defect with the sidestand bracket assemblies on certain 2005 XB12R, XB12S, XB9SX model motorcycles.

Motorcycles Affected

This campaign involves a small number of 2005 domestic and international Buell motorcycles manufactured from January 11th through January 17th, 2005. The sidestand may not retract 5 degrees as designed when the vehicle is lifted off the sidestand. This situation may not allow the sidestand to retract automatically if contact is made with the ground when the vehicle is in motion. This could in turn disrupt the stability of the motorcycle leading to a crash thereby, causing death or injury to the rider.

Replacement Sidestand Pivot Bolts

See Figure 1. Correcting the potential safety defect requires replacement of the sidestand pivot bolt, Part No. L0174.1AA. The replacement pivot bolt, Part No. L0174.1AAB, is 0.100 in. (2.5 mm) longer in the spring plate pin area and has a gold hue plating. **The recall kit Part No. is 94394Y.**

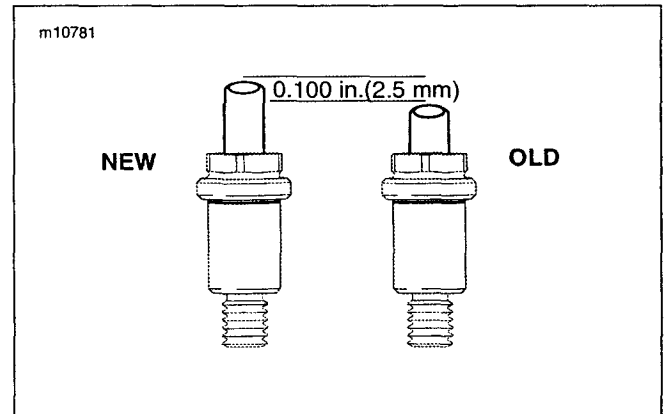

Figure 1. Correct Pivot Bolt with Springplate Pin

IMPORTANT NOTE

In the interest of preserving customer safety and satisfaction, always check for outstanding recalls whenever any motorcycle is brought into your dealership for either maintenance or service.

ROUTING	SERVICE MANAGER	SALES MANAGER	PARTS MANAGER	LEAD TECHNICIAN	TECHNICIAN NO.1	TECHNICIAN NO. 2	TECHNICIAN NO. 3	TECHNICIAN NO. 4	RETURN THIS TO
INITIAL HERE									

Customer Notification

If any vehicles involved in this recall campaign have been shipped to your dealership, a VIN list will be attached to this bulletin. To ensure the safety of our riders, it is your responsibility to perform the required service on all affected vehicles, even if the motorcycle was not purchased from your dealership. You also are required to perform the recall service on all affected vehicles in your dealership inventory, prior to delivering or leasing those vehicles.

If you are not sure that the safety recall service has been completed on a particular motorcycle, recall information is available on TALON and h-dnet.com.

IMPORTANT NOTE

Because only registered owners as shown on the attached list will receive notification from us, we request that you contact any owners of vehicles still listed as unregistered. Advise them of the safety recall and make arrangements for them to come in for recall service. We also require that you provide us with their names, addresses and VIN's as soon as possible to enable us to mail them an owner's letter, as required by the National Traffic and Motor Vehicle Safety Act (as amended).

A single shipment of Safety Recall Code 0830 kits, Part No. 94394Y, will contain 100% of your total estimated kit requirements. Shipments will begin the week of May 2nd, 2005.

All kits will be shipped no charge, transportation paid. If additional kits are needed, fill in the attached order form and fax it to the Warranty Department at 414-343-8346.

Because we have shipped you your total kit requirements, a VIN will be required to obtain any additional no charge pivot bolt recall kits.

NOTE

*Do not send in orders for additional kits **until** you have received your initial shipment and have determined your remaining kit requirements. Orders received before the initial shipment is complete will be discarded. Buell Motorcycle Company reserves the right to conduct wave shipments in lieu of processing individual orders and/or adjusting order quantities, depending on the availability of replacement parts.*

To avoid an excess of unneeded kits in the field, please order responsibly.

Required Dealer Action

The sidestand is located on the left side of the motorcycle. The sidestand swings outward to support the motorcycle for parking.

Sidestand Disassembly

NOTES

- Vehicle should be placed onto the lift with front or rear tire placed in the wheel vise in order to successfully perform this procedure.
- Sidestand assembly does not have to be removed from motorcycle in order to remove sidestand pivot bolt.

1. Remove two fasteners from left side of chin fairing.
2. See Figure 2. Remove sidestand pivot bolt (4).
 - a. Retract sidestand leg.
 - b. Remove sidestand spring (5) and spring extension plate (3) using SNAP-ON SPRING TOOL (Part No. HE-52B).
 - c. Remove sidestand pivot bolt (4).

Sidestand Assembly

1. Install **new** longer sidestand pivot bolt (4).
 - a. See Figure 3. Lubricate sidestand pivot bolt and mating portions on sidestand bracket with WHEEL BEARING GREASE (Part No. 99855-89) on shaded areas only.
 - b. See Figure 4. Apply LOCTITE 272 (Red) to threaded area (clevis) of sidestand leg.

NOTE

Applying LOCTITE to threaded area of clevis on sidestand leg, instead of threads on the pivot bolt, will eliminate build-up between clevis and sidestand bracket which can interfere with the applied lubricant.

- c. See Figure 2. Install sidestand pivot bolt (4) tightening to 18-20 ft-lbs (24-27 Nm).
- d. Retract sidestand leg.
- e. Install spring extension plate (3) and sidestand spring (5) using SNAP-ON SPRING TOOL (Part No. HE-52B).

2. Apply LOCTITE 272 (Red) and install the two left side chin fairing fasteners and tighten to 36-48 in. lbs (Nm).

NOTE

Extension plate should curve below primary chain adjustment screw to allow for clearance around adjustment screw.

3. Inspect sidestand for correct operation.

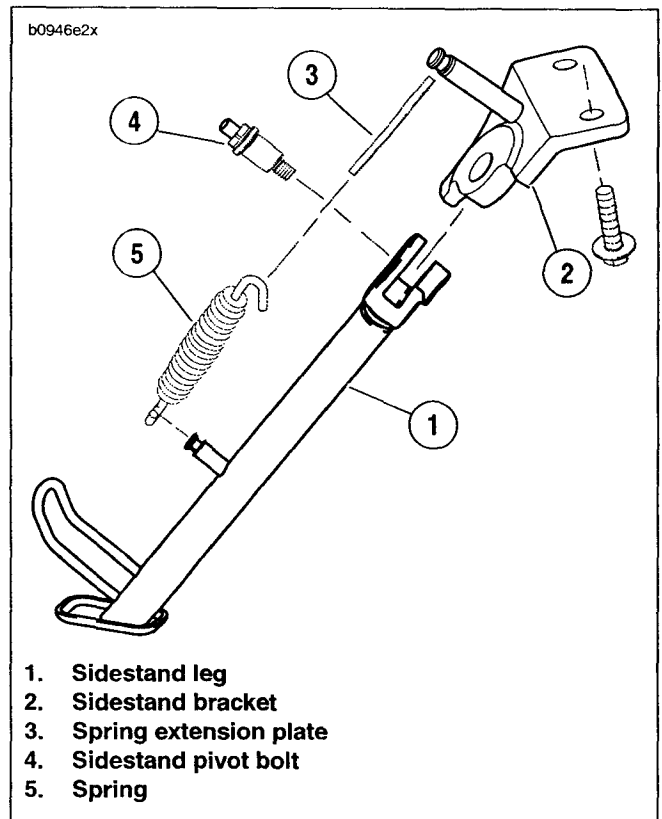

Figure 2. Sidestand Assembly

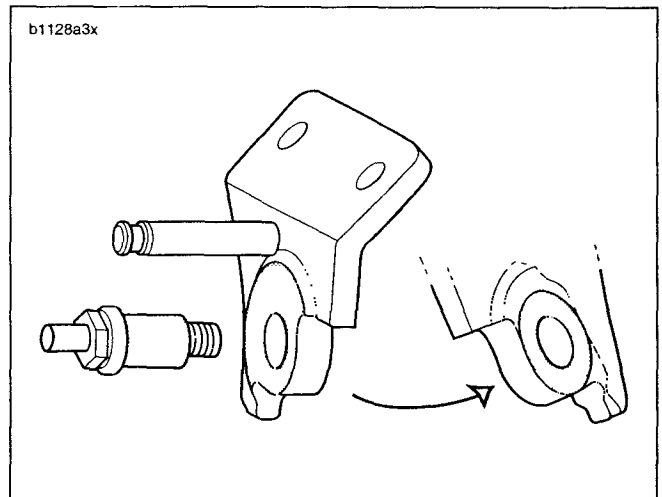

Figure 3. Lubricating Points (Shaded Areas)

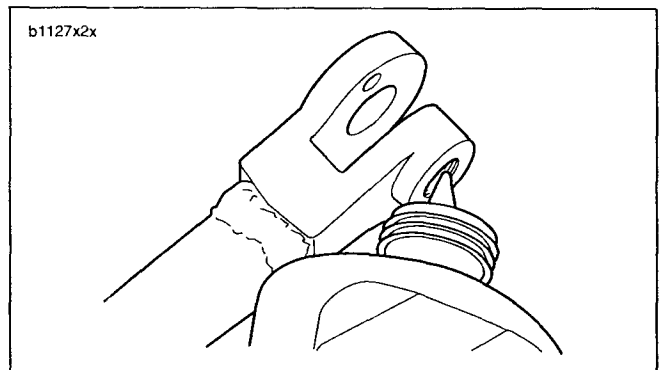

Figure 4. Threaded Area for Loctite Application

Credit Procedure- Vehicle Repair

For each vehicle serviced, place a "C" in the letter box on the Buell Dealer Service Card. Package the original pivot bolt and the properly completed Buell Dealer Service Card and send to Buell Motorcycle Company, 3700 W. Juneau Ave., Milwaukee, WI 53208.

Upon receipt of each replaced pivot bolt and the properly completed Buell Dealer Service Card, you will be credited 0.5 hrs. labor. This credit also covers administrative time, return postage, grease and LOCTITE. No credit will be issued for parts as replacement parts were sent no charge, transportation paid.

NOTE

The actual time for replacement of the pivot bolt, including 0.1 hr. for administration time, has been determined to be a total of 0.2 hr. Because of the disruption to your service operation caused by this situation, and as a small incentive to help achieve a high percentage of completion, the dealership will be compensated 0.5 hr. for this task.

Credit Procedure- Parts In Dealer Stock

Remove all affected pivot bolts (Part No. L0174.1AA) from your inventory. To receive credit, complete a regular warranty claim referencing Service Bulletin B-060 in the "Description of Repair" section. Fill in the rest of the claim as follows:

Table 1. Credit for Parts in Dealer Stock

Claim Type	BDS
QTY. EVENT 1	See Note Below
Event 1, Problem Part No.	L0174.1AA
Part Description	sidestand pivot bolt
Customer Concern Code	9205
Condition Code	2107

NOTE

"Quantity" will vary depending upon what you have in stock.

Upon receipt of properly completed claim for parts in dealer stock, you will receive a bar coded label to return the recalled pivot bolts. To receive the appropriate credit for parts and return postage, you must return the pivot bolts by the due date on the bar coded label.

IMPORTANT NOTE

It is very important that you return the replaced parts to receive appropriate credit and so we can update our records appropriately.



DEALER COMMUNICATIONS

Buell Motorcycle Company

Dealer Department Routing				
<input checked="" type="checkbox"/>	Dealer Principal	<input type="checkbox"/>	General Merchandise	<input type="checkbox"/> Parts
<input checked="" type="checkbox"/>	General Manager	<input type="checkbox"/>	BRAG	_____
<input type="checkbox"/>	Office Manager	<input type="checkbox"/>	F&I Manager	_____
<input checked="" type="checkbox"/>	Vehicle Sales Manager	<input checked="" type="checkbox"/>	Service	_____

April 20, 2005

Subject: Safety Recall Campaign 0830

Dear Buell Dealer:

Buell Distribution Company, LLC has learned that a condition affecting safety exists on certain 2005 Buell model year XB12S, XB12R and XB9SX Motorcycles built from January 11, 2005 through January 17, 2005. This condition involves the sidestand. The sidestand may not retract 5 degrees as designed when the vehicle is lifted off the sidestand. This situation may not allow the sidestand to retract automatically if contact is made with the ground when the vehicle is in motion. This could in turn disrupt the stability of the motorcycle leading to a crash thereby, causing death or injury to the rider.

We have voluntarily declared this a defect related to motor vehicle safety (Campaign 0830) to allow us to formally recall all affected motorcycles and parts. The remedy of this issue is to replace the sidestand pivot bolt, part number L0174.1AA, with a similar bolt that is .100 inch longer.

In the interest of the safety of our mutual customers and as required by law, you may sell but NOT DELIVER any affected motorcycles to your customers. A service bulletin outlining the repair and credit procedure, along with the list of affected VINs will follow within two weeks. This bulletin will also contain the credit procedures required to handle the sidestand bolt replacement.

In accordance with Federal regulations administered by NHTSA, Buell Distribution Company, LLC will provide notice to all owners of record of affected products with direction to bring the vehicle in for the recall service.

Sincerely,

Buell Distribution Company, LLC



BUELL MOTORCYCLE COMPANY
3700 WEST JUNEAU AVE. MILWAUKEE, WI 53201
414.342.4680 | buell.com

SAMPLE COPY

April 27, 2005

Dear Buell Motorcycle Owner:

This notice is being sent to you in accordance with the requirements of the National Traffic and Motor Vehicle Safety Act.

Buell Distribution Company, LLC has decided that a defect which relates to motor vehicle safety exists in certain 2005 Buell model XB12S, XB12R and XB9SX motorcycles built from January 11, 2005 through January 17, 2005. The defect may not allow the sidestand to automatically retract as designed if contact is made with the ground when the vehicle is in motion. This could in turn disrupt the stability of the motorcycle leading to a crash thereby, causing death or injury to the rider.

Our records indicate that you are the owner of one of the above listed motorcycles involved in this safety recall as identified by the VIN (Vehicle Identification Number) shown on the enclosed Dealer Service Card.

We strongly urge you to take your motorcycle to your dealer to have the appropriate service performed as soon as possible. If you had this repair before you received this letter, you may be eligible to receive reimbursement for the cost of obtaining a pre-notification remedy of the problem associated with this recall. For more information contact Buell Distribution Company, LLC at 1-414-343-8400. Should you choose to ride your motorcycle prior to this service, we urge you to be aware of this condition.

Please contact your Buell motorcycle dealer immediately and arrange an appointment to have your sidestand repaired. The dealer labor time to perform this service takes approximately 30 minutes or less and the parts and labor will be free of charge to you. Parts should be available at your dealership the week of April 25th, 2005.

To verify that the service has been completed your Dealer will ask you to sign a recall claim. If you have sold your motorcycle, please forward the appropriate information about your purchaser. This will enable us to contact him/her and advise that person of

this recall. Also, Federal regulation requires that any vehicle lessor receiving this recall notice must forward a copy of this notice to the lessee within ten days.

If you take your motorcycle to your dealer on a mutually agreed-upon date and he does not perform the required service to your satisfaction, please contact Buell Distribution Company, LLC for immediate assistance at the address or telephone number listed on this letterhead. If your dealer or Buell Distribution Company, LLC fails or is unable to remedy your motorcycle without charge within a reasonable time, you may wish to inform the Administrator, the National Highway Traffic Safety Administration, 400 Seventh Street, SW, Washington, DC 25090, or call the toll free Auto Safety Hotline at 1-888-DASH-2DOT or contact NHTSA at www.NHTSA.DOT.GOV.

We regret any inconvenience this may cause you, but we are initiating this action in the interest of your personal safety and satisfaction with our products. Thank you for your cooperation.

Sincerely,

Buell Distribution Company, LLC

**Buell Pre-Notification
Remedy Reimbursement Program**

Recall Summary

(1) Buell Distribution Company, LLC is recalling certain 2005 Model Year XB12S, XB12R and XB9SX motorcycles built between, January 11, 2005 through January 17, 2005. Our records indicate that you purchased one of these motorcycles covered in this recall campaign. The defect in this recall condition involves the sidestand, which was designed to retract 5 degrees when the vehicle is lifted off the sidestand. This condition may not allow the sidestand to retract automatically if contact is made with the ground when the vehicle is in motion. This could in turn disrupt the stability of the motorcycle leading to a crash, thereby causing death or injury to the rider.

Reimbursement Program

(2) Our program for reimbursing a claimant who incurred costs prior to this recall for a remedy involving the defect which is the subject of this recall is as follows: subject to the limitations and qualifications noted below, we will reimburse the lesser of the dollar amount you paid for the remedy or your cost of remedy parts [at the Buell list price for related, authorized parts], labor at local rates, and associated costs such as taxes and disposal fees.

Our remedy in this recall involves replacing the sidestand pivot bolt, part number L0174.1AA, with a similar bolt that is .100 inch longer. If this bolt, the entire

sidestand assembly, or the sidestand bracket has been replaced previously to remedy this situation, you may be eligible for reimbursement. These are the only type of pre-notification remedy eligible for reimbursement consideration.

Time Limitation

(3) The covered pre-recall remedy of your motorcycle must have occurred no later than May 13, 2005.

Exclusions

(4) Buell's Pre-Notification Remedy Reimbursement Program does not include reimbursement:

(a) for costs incurred while our original warranty, or an extended warranty as to which we gave written notice in either case, was in effect and would have provided a free remedy (without any consumer payment) of the problem involved in the recall, unless our authorized dealer or representative denied warranty coverage to you or the warranty repair did not remedy the problem involved in the recall;

(b) for a pre-notification remedy which was not of the same type as the Buell recall remedy, which is replacing the sidestand pivot bolt, the sidestand assembly, or the bracket.

(c) for a pre-notification remedy that did not address the defect involved in the recall;

(d) for a pre-notification remedy that was not reasonably necessary to correct the defect involved in the recall;

(e) for a pre-notification remedy involving a motorcycle first purchased more than 10 calendar years before the recall notice letter in this recall campaign was provided to owners or purchasers by Buell; or

(f) for insufficient documentation of your claim for pre-notification reimbursement, as specified immediately below. If this is the case, you will be given an opportunity to resubmit the claim with the complete information.

Required Claim Documentation

(5) To process your claim, Buell must have:

(a) your name and mailing address;

(b) the make, model, model year and vehicle identification number (VIN) of your motorcycle;

(c) the recall campaign number (you may provide either the NHTSA or Buell recall number);

(d) name of the owner or purchaser of the motorcycle with the recall at the time the pre-notification remedy was obtained;

(e) a copy of the receipt for the pre-notification remedy, which, in the case of a replacement of a motorcycle part or component, a copy of the receipt identifying the part, etc. involved and stating the total amount paid for the part, etc. which replaced the defective item; and

(f) if the pre-notification remedy was obtained when your motorcycle could have been remedied at no charge under a Buell original or extended warranty,

documentation indicating that our authorized dealer or facility either refused or failed to remedy the recall problem under our warranty program.

Where to File a Claim

(6) Claims for reimbursement, with the requisite documentation as itemized above, should be mailed to:

Buell Distribution Company, LLC
Attn: Customer Service
3900 W. Juneau Avenue
Milwaukee, WI 53208

Call Us With Your Questions

(7) It is as important to us as it is to you that you understand the terms of our pre-notification reimbursement program. If you have any questions about the program or its possible application to you, please call us at 1-414-343-8400.

As always, Buell stands behind its products and wants to assure your continued satisfaction with your Buell motorcycle.

Buell Distribution Company, LLC