

FILE: SERVICE: GROUP 00 OF SERVICE INFORMATION BINDER
PARTS: GROUP I OF INFORMATION – PARTS & ACCESSORIES BINDER

Campaign No. 2005070007

August 2005

TO: ALL MERCEDES-BENZ CENTERS

SUBJECT: **MODELS 211, 230**
MODEL YEAR 2004
INSPECT SBC HYDRAULIC UNIT, REPLACE AS DIRECTED

This Recall Campaign has been initiated because DCAG has determined that on the affected vehicles (see VIN range below) the SBC brake system may prematurely shift to the hydraulic back up mode due to the loosening of the ground wire harness connection over time, or due to premature failure of the hydraulic pump. On Model 211, dealers will install a bracket and replace the ground wire, and if required, replace the hydraulic pump and suction hose. On Model 230, dealers will install a bracket and replace the ground wire, replace the suction hose, and if required replace the hydraulic pump.

Note:

This recall campaign has been divided into two parts:

- I **MODEL 211**
INSPECT SBC HYDRAULIC UNIT, REPLACE AS DIRECTED (PAGES 1-17)
- II **MODEL 230**
INSPECT SBC HYDRAULIC UNIT, REPLACE AS DIRECTED (PAGES 18-32)

Note:

With the launch of this campaign, 211 and 230 vehicles subject to last years SBC Recall Campaign No. 2004050014 that have not been repaired to date have been excluded from last years campaign and will no longer appear in VMI as an "Open" campaign. All vehicles subject to last years SBC recall, both "Open" and "Closed" will be campaigned under this years SBC campaigns.

Please review the Effective Serial Number Chart located below.

Attached is a sample copy of a letter which owners of the affected vehicles will receive.

Prior to performing this Recall Campaign:

- Please check VMI to insure the vehicle is involved and to determine if the vehicle has been previously repaired.
- Please review the entire Recall Campaign bulletin.

Approximately 15,979 vehicles are involved.

Order No. P-RC-2005070007

This bulletin has been created and maintained in accordance with MBUSA-SLP S423QH001, Document and Data Control, and MBUSA-SLP S424HH001, Control of Quality Records.

Effective Serial Number Range

Models	Chassis End Number	
	From	To
211.006	A470365	A475255
211.026	A470992	A508719
211.061	A461620	A461620
211.065	A457431	A511132
211.070	A457447	A511135
211.076	A457425	A510794
211.082	X119124	X123272
211.083	X119111	X123267
211.206	A465748	A465748
211.265	A457426	A510952
211.282	X119113	X123268
211.283	X119110	X123264
230.474	F070784	F077518
230.475	F070783	F077529
230.476	F070797	F077483

**I MODEL 211
INSPECT SBC HYDRAULIC UNIT, REPLACE AS DIRECTED**

Procedure

A. INSPECTION OF SBC HYDRAULIC UNIT

1. Check if part number (A, Figure 1) is listed in the table below:
 - If the part number (A) **is** listed, proceed to step 2.
 - If the part number (A) is **not** listed proceed to step 3.

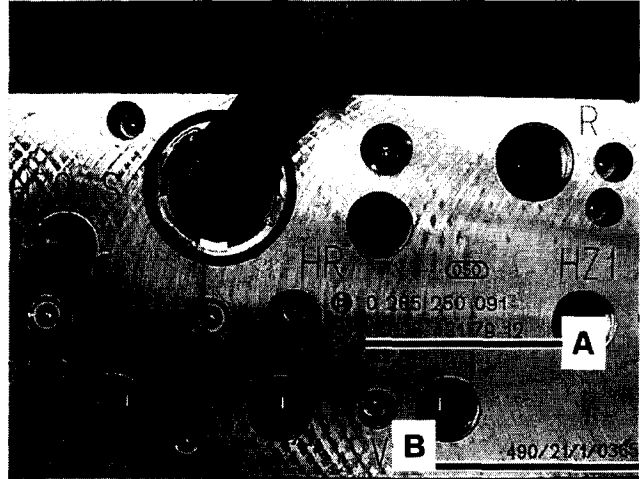

Figure 1

2. Check (refer to table below) if the production number (B, Figure 1) is within the listed production number range for the relevant part number (A):
 - If the production number (B) is **not** within the production number range proceed to step 3.
 - If the production number (B) **is** within the production number range compared to the relevant part number; proceed to Subject **B**, Replacement of SBC Hydraulic unit.
(E.g., for SBC hydraulic unit part number: A 005 431 68 12. The production number 392/08/1/0500 is not within the number range - campaign completed. The production number 392/11/1/0700 is within the number range – proceed to Subject B, Replacement of SBC Hydraulic unit).
3. Do **not** replace SBC Hydraulic unit or the suction hose. Only perform the installation of ground wires and bracket to the SBC wiring harness. Proceed to Subject B and perform the following steps **only**: 1-4, 11-23, 26-30, and 32.

Table

Part number	Production number	
	From	To
A 005 431 68 12	392/09/1/0496	392/12/1/0641
A 005 431 05 12	391/24/1/0680	481/08/1/0290
A 004 431 82 12	392/10/1/0244	392/18/1/1198
A 005 431 06 12	392/01/1/1152	481/08/1/0165
A 004 431 83 12	392/08/1/0525	392/08/1/0534

Note:

When reading the production number (B, Figure 1) on the SBC hydraulic pump, disregard the slashes.

The production number should be read as a whole number:
e.g., 392/08/1/0534 = 3,920,810,534

B. REPLACEMENT OF SBC HYDRAULIC UNIT (MODEL 211)

WARNING!

Risk of injury caused by body parts being pinched or crushed. Risk of injury to skin and eyes caused by brake fluid spraying out at high pressure when working on the SBC brake system.

Risk of poisoning from swallowing brake fluid.

Pour brake fluid only into suitable and appropriately marked containers. Wear protective clothing and eye protection when handling brake fluid.

1. Deactivate SBC using Star Diagnosis.
2. Disconnect SBC hydraulic unit harness connector (C, Figure 2).
3. Remove mounting strap (A, Figure 2) and reposition hose and strap (A) to create more working space.
4. Detach SBC hydraulic unit ground wire (arrow, Figure 2) at terminal stud (B).
5. Position harness connector (C, Figure 2) away from SBC hydraulic lines to prevent brake fluid from dripping on SBC harness connector and SBC wiring harness.
6. Remove SBC hydraulic unit (D); refer to WIS: AR42.46-P-0010R, steps 1 – 11.
7. Remove combination filter housing, refer to WIS: AP83.00-P-8384TA (do not replace combination filter).
8. Remove suction hose (A, Figure 3):
 - Remove and discard hose clamp (arrow) where suction hose is connected to suction line (B).

CAUTION:

Do not use sharp-edged tools (e.g., screwdriver) to remove suction hose (A, Figure 3) from SBC suction line (B), this may cause damage to the suction line (B) and possible SBC brake system malfunctions.

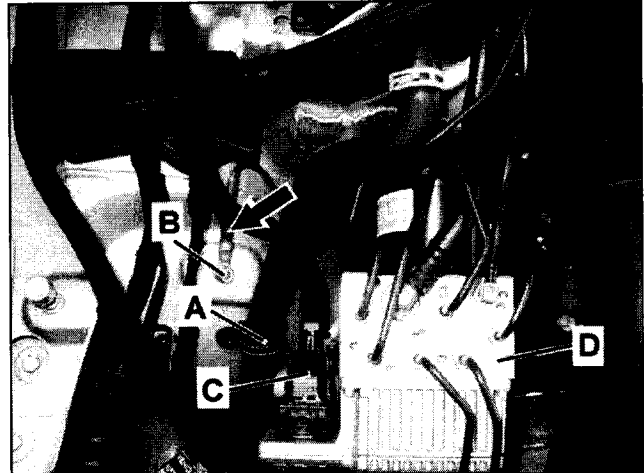

Figure 2

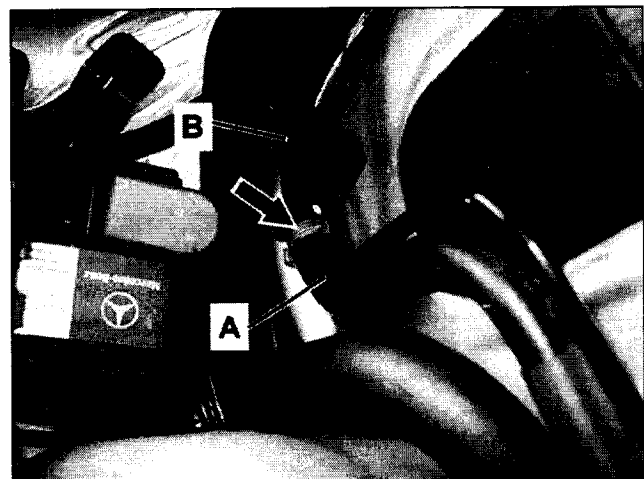

Figure 3

- Carefully detach suction hose (A, Figure 3) from the suction line (B) using a plastic wedge (Example: Special Tool: W110 589 03 59 00).

Note:

- When removing suction hose (A, Figure 3), do not bend suction line.
- To prevent brake fluid from running out and to prevent contamination in the brake system, the suction hose (A, Figure 3) and line (B) are to be plugged using suitable plugs from the stop plug kit (Special Tool: W129 589 00 91 00).
- Discard old suction hose (A) and clamp (arrow) after removal.

**Figure 4**

9. Check if a pulsation damper (B, Figure 4) was installed on suction hose:

- If pulsation damper (B) was **not** installed: Install new standard suction hose (A) to suction line, secure with new hose clamps (arrows).
- If pulsation damper (B) **was** installed: Install new suction hose (A) with double pulsation damper to suction line, secure with new hose clamps (arrows).

10. Reinstall combination filter housing in reverse order.

11. Remove cable tie (arrow, Figure 5) securing SBC wire harness (A) to SBC connector housing (B).

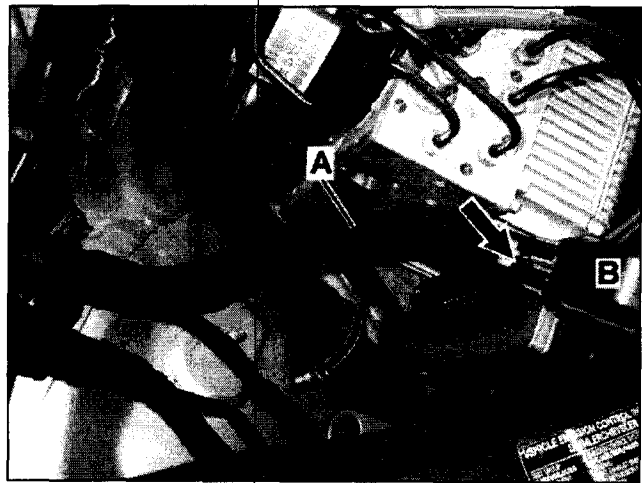
**Figure 5**

12. Remove fabric tape (arrows, Figure 6) from wire harness (A) up to rubber grommet (B).

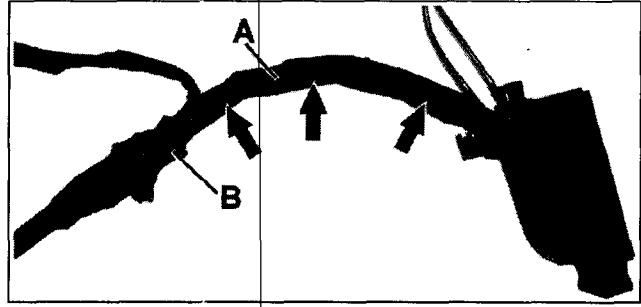

Figure 6

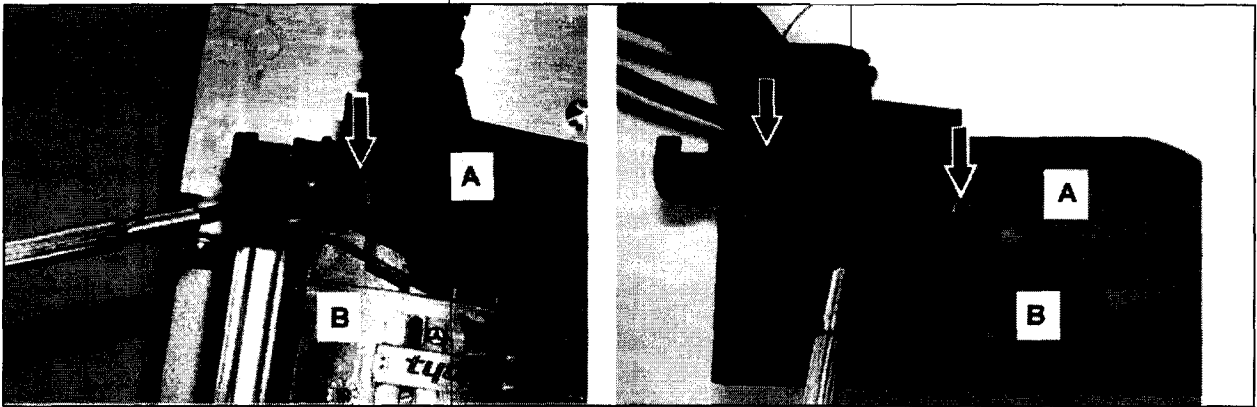

Figure 7

13. Remove SBC connector housing (A, Figure 7) cover:

- Using a small screwdriver, carefully pry cover (A) away from locking lugs (arrow) until it disengages.
- Repeat the process on opposite side.
- Remove the cover (A) from the housing (B).

Note:

There are two different versions of the SBC wiring harness connector (Figure 8a, b) installed in vehicles involved with this campaign.



Figure 8a (Connector Type A)

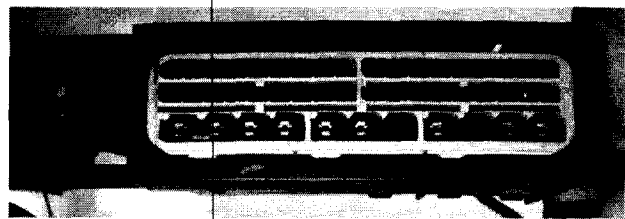

Figure 8b (Connector Type B)

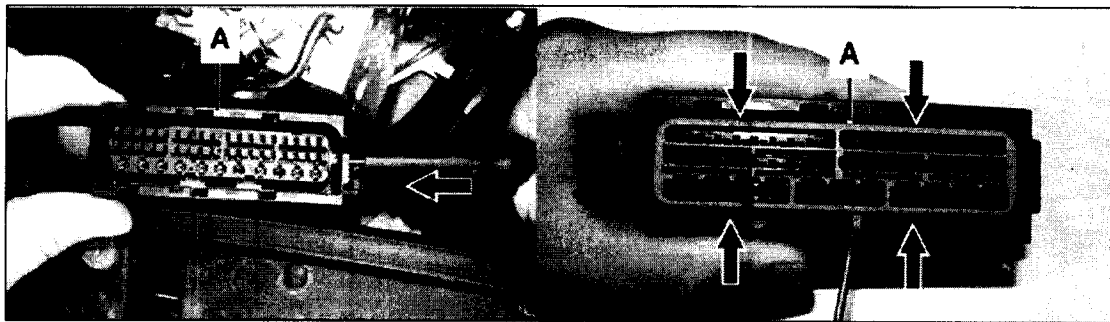

Figure 9a (Connector Type A)

Figure 9b (Connector Type B)

14. Open (gray) secondary lock in the SBC connector housing (A, Figure 9):

Connector Type A:

Slide the secondary lock in the direction indicated by the arrow (Figure 9a) using a small screwdriver to release lock.

Connector Type B:

Pry upwards using a small screwdriver as indicated by arrow (Figure 9b) to disengage the secondary lock.

15. Remove ground wires (arrows, Figure 10) from SBC harness connector (A):

- Unpin SBC ground wire connectors (position 37 and 44, Figure 10) using cable release tool and remove from SBC connector housing (A) (Special Tools: W 000 589 13 99 30 and W 220 589 01 99 50).
- Discard old ground wire harness, it is no longer needed.

16. Insert the new ground wiring harness (arrows Figure 10) into the SBC connector housing (A):

- Insert **longer** ground wire into position 44.
- Insert **shorter** ground wire into position 37.

Note:

Ensure ground wire connectors are **properly** locked into place.

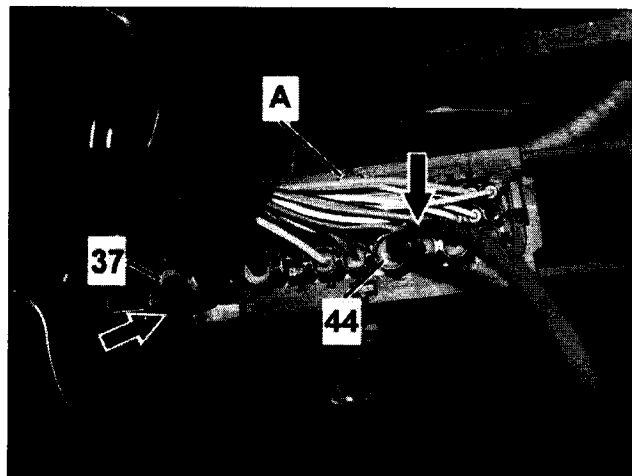

Figure 10

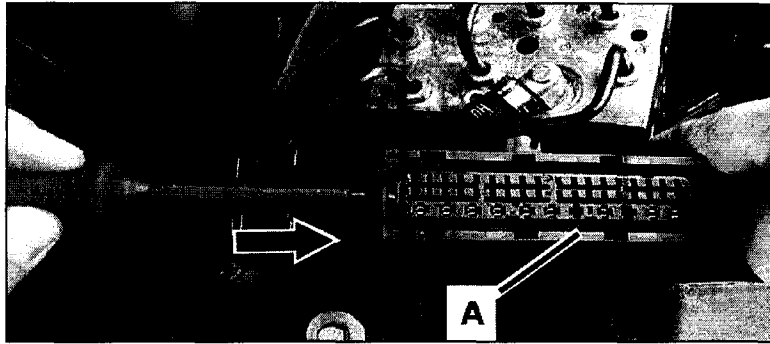

Figure 11a (Connector Type A)

17. Close the (gray) secondary lock of the SBC connector housing (A, Figure 11):

Connector Type A:

Slide the secondary lock in the direction indicated by the arrow (Figure 11) using a small screwdriver until it locks into place.

Connector Type B:

Place secondary lock on top of connector and snap back into place.

18. Loosely wrap the exposed SBC wire harness using fabric tape (arrows).
Do not wrap the ground wiring harness (A, Figure 12) into the SBC wire harness.

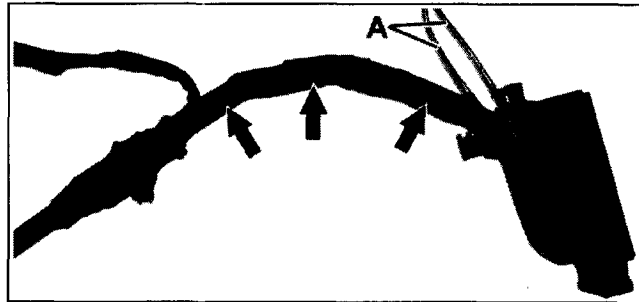

Figure 12

19. Reinstall the SBC wire harness connector cover (A, Figure 13) in reverse order.

Note:

Ensure the locking lugs (arrows) on the harness connector (B) are properly engaged into the harness connector cover (A).

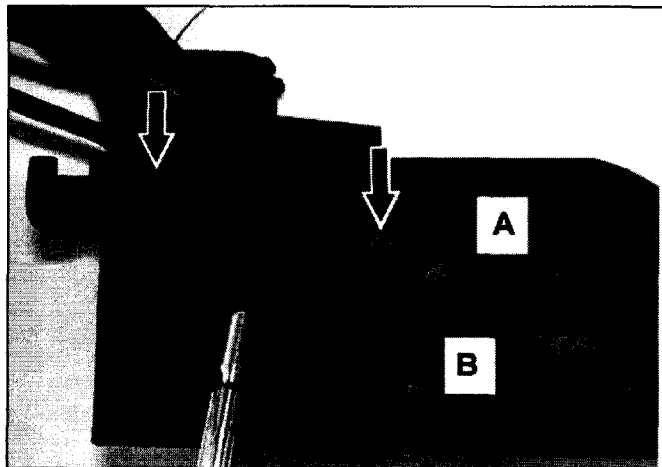

Figure 13

20. Secure the SBC wiring harness (A, Figure 14) (**excluding** ground wiring harness) to the SBC connector cover harness receptacle (D) using a new cable tie (arrow).

Note:

- Ensure that the SBC wiring harness (A) is properly routed so that it is free of tension in the SBC connector housing.
- The cable tie "buckle" (C) **must be located on the side of the connector cap harness receptacle (D) as depicted.**

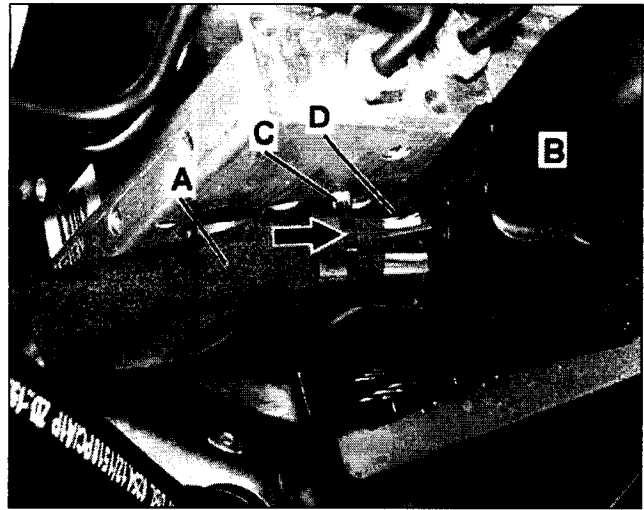

Figure 14

21. Secure ground wiring harness (arrow, Figure 15) to SBC wire harness (A) using two layers of fabric tape (B). Tape should be affixed 35 mm (X = 35 mm, Figure 15) from end of connector cover receptacle (C).

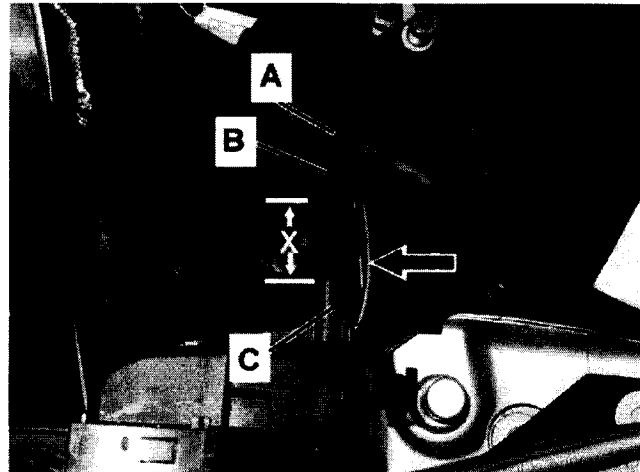

Figure 15

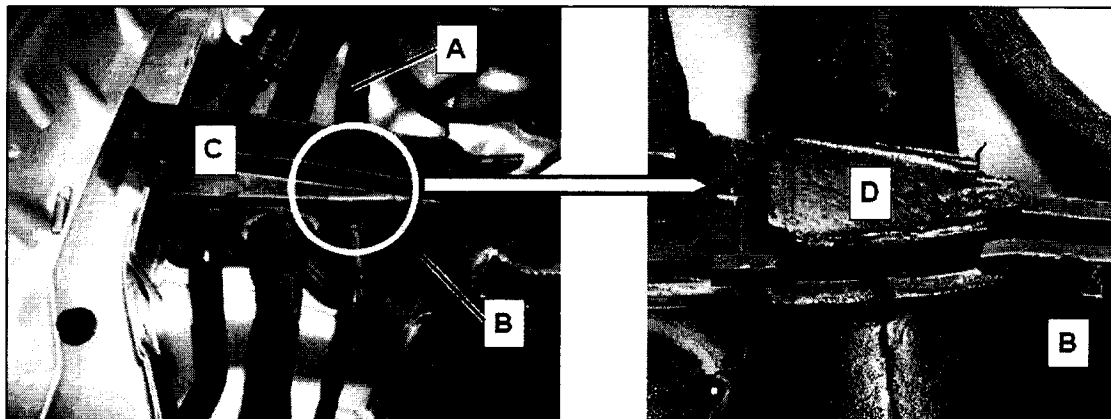

Figure 16

22. Remount the SBC wiring harness (A, Figure 16) in the wire harness guide (B):
- Remove wire harness guide cover (C) and remove SBC wiring harness with grommet (D) from harness guide (B).

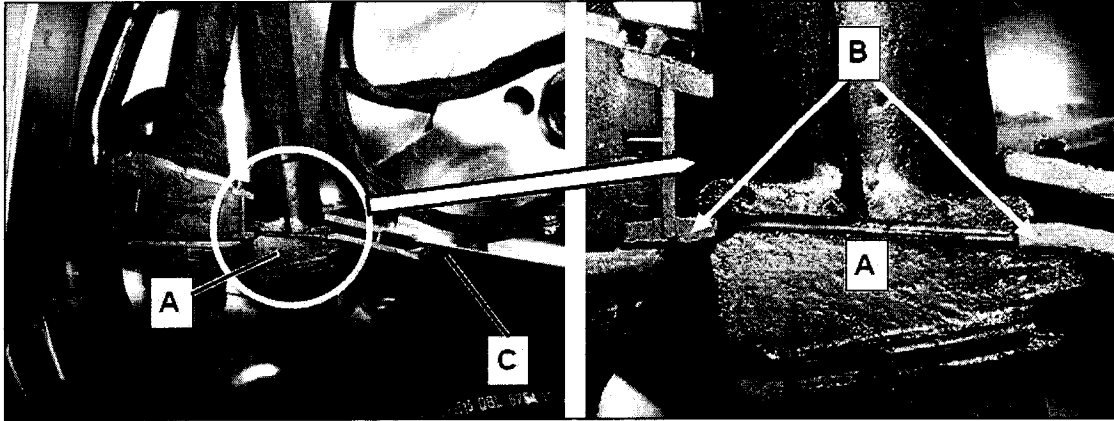

Figure 17

- Reposition SBC wiring harness with grommet (A, Figure 17) into the forward wall opening (B) in the wire harness guide (C).

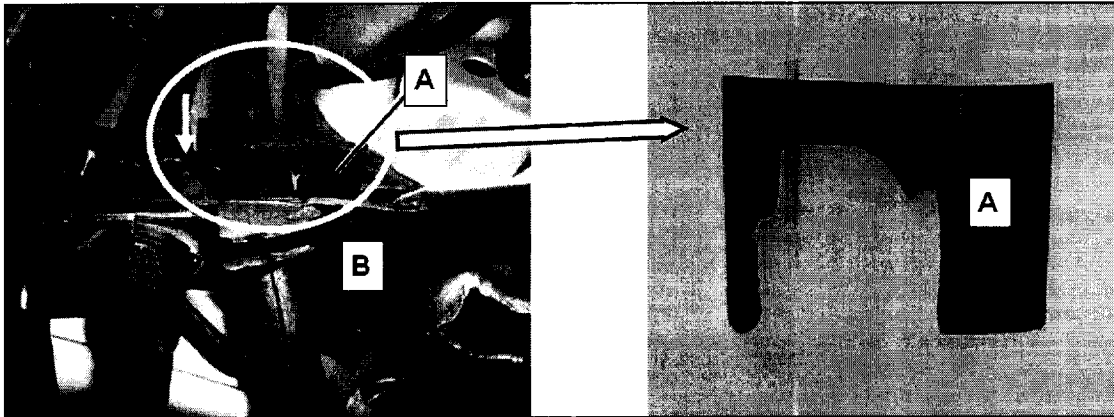

Figure 18

- Insert new routing clip (A, Figure 18) into wire harness guide (B) until top of clip (A) is flush with top of wire harness guide (B).
- Reinstall top of wire harness guide (C, Figure 16).

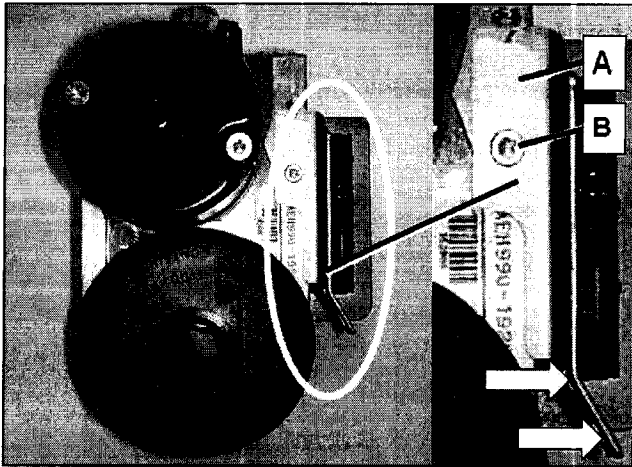

Figure 19

23. Attach bracket (A, Figure 19) to the SBC hydraulic unit:

- Using hand tools, tap threads into SBC hydraulic unit bores by running self tapping screw (B) into lower bore **without** mounting bracket positioned on SBC unit.

Note:

- In order to avoid breaking the self-tapping screw (B) during installation, the screw (B) must be **positioned absolutely straight**
- Do not use power tools to install self tapping screw.
- Remove self tapping screw (B).
- Position bracket (A) on SBC hydraulic unit, reinstall self tapping screw (B) and **torque to 7 Nm**.

24. Install new SBC hydraulic unit (B, Figure 20) into SBC body mounting grommets.

25. Connect hydraulic lines and SBC suction hose (A) to SBC hydraulic unit (B); refer also to WIS: AR42.46-P-0010R steps 12 – 16.

Note:

Ensure new hose clamp (C) is installed.

26. Insert a cable tie through slot (arrows, Figure 19) in bracket, **do not** close cable tie.

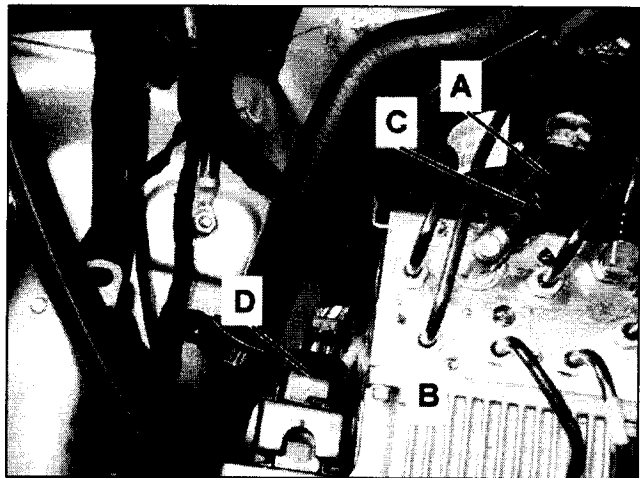

Figure 20

27. Connect the SBC wire harness connector (D, Figure 20) to the SBC hydraulic unit (B) and secure by engaging locking mechanism.

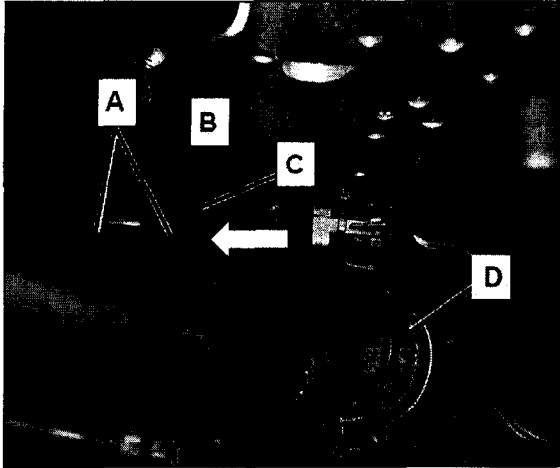

Figure 21

28. Secure ground wiring harness and SBC wiring harness (A, Figure 21) to SBC hydraulic unit bracket (B) with cable tie (arrow). Torque cable tie (arrow) with cable tie pliers (Special Tool) to **150 – 170 Nm** (torque setting 4 on the cable tie pliers) (Special Tool: W 352 589 02 37 00).

Note:

- The cable tie buckle (C) must not touch the bracket (B).
- When mounting the wiring harness set (A) to the bracket (B), ensure that the wiring harness set (A) touches the bracket (B) and is mounted there tension free.
- After the SBC wire harness set (A) is secured, it must not be able to move in the longitudinal direction toward the bracket.

29. Attach hose mounting strap (D, Figure 21) to mounting stud, secure with nut.

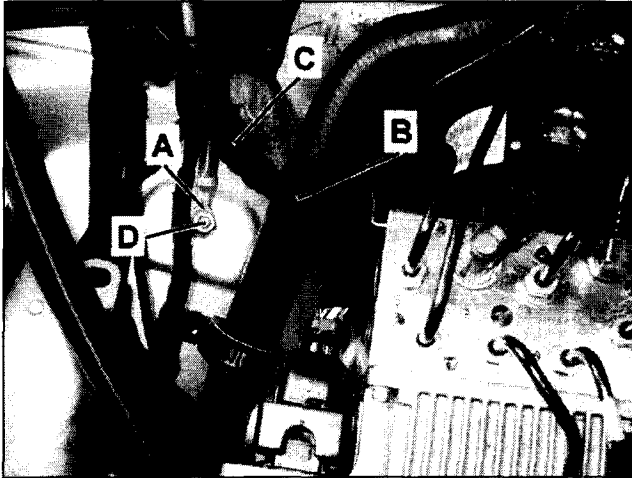

Figure 22

30. Position ground wiring harness parallel to the vehicle longitudinal axis (X-axis) on the body ground terminal. Torque the M6 nut to 10 Nm.

Note:

- Ring connector (A, Figure 22) **must** be positioned as shown to avoid contact with water hose (B) and chafing the wire harness (C).
- This ground terminal (D) is to be used **only** for mounting the SBC ground wire.

31. Complete the installation of the SBC hydraulic unit; check for leaks and bleed SBC system (refer to WIS: AR42.46-P-0010R), (Refer to SDS instructions).

Note (regarding above WIS instructions):

Step 18: When checking for leaks, maximum pressure for brake bleeder is **2.5 bar**.

32. Check software release of the SBC by navigating through the following menu items in DAS and update if necessary:

"Control units/Chassis/SBC/Sensotronic Brake Control/Control unit adaptations"

Ensure to follow the on-screen instructions in DAS.

Special Tools

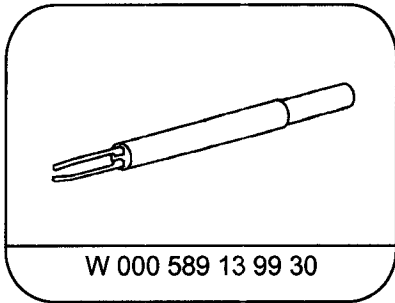

W 000 589 13 99 30

Blade

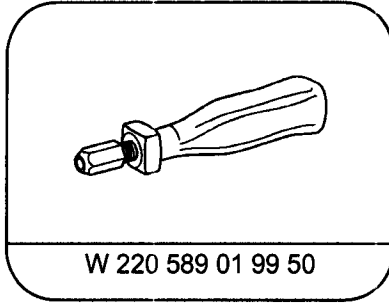

W 220 589 01 99 50

Handle

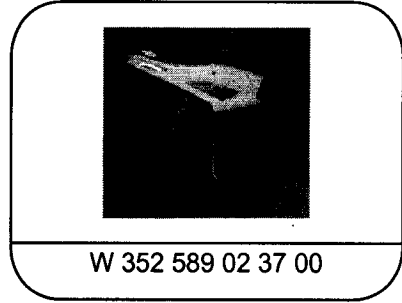

W 352 589 02 37 00

Cable tie pliers

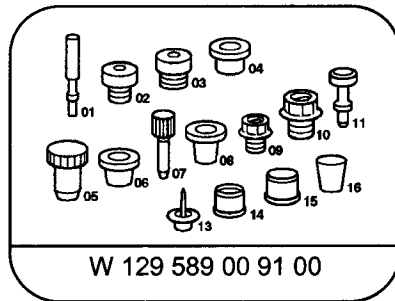

W 129 589 00 91 00

Stop Plug Kit

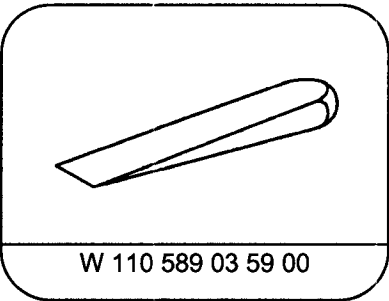

W 110 589 03 59 00

Plastic Wedge

Special Tools Information

Special Tool Number	Group/ Category	Description	Dir Net
W 000 589 13 99 30 ¹⁾	00/ B	Blade; MCP/ JPT/ SPT	\$ 41.00
W 220 589 01 99 50 ¹⁾	00/ B	Blade Holder	\$ 9.00
W 352 589 02 37 00 ²⁾	54/ C	Tension Tool; Cable Tie	\$ 296.00
W 129 589 00 91 00 ³⁾	77/ K	Plug Set; Hydraulic	\$ 98.00
W 110 589 03 59 00 ⁴⁾	72/ K	Mounting Wedge	\$ 19.50

Note:

¹⁾ Special Tool W 000 589 13 99 30 is interchangeable with W 220 589 01 99 61. Special Tool W 000 589 13 99 30 is the latest replacement for an existing Special Tool W 220 589 01 99 61, released and automatically delivered to all MBUSA dealers in the Wiring Harness Repair Kit: Special Tool W 220 589 01 99 00 (and later as W 220 589 02 99 00).

²⁾ Special Tool W 352 589 02 37 00 will be released and automatically delivered to each MBUSA dealer.

³⁾ This required Special Tool should already be in stock at each MBUSA dealer location.

⁴⁾ This is a sample Special Tool number provided for your reference.

Required Equipment Information

Equipment Part Number	Description	MFR.
275-ST-BBE-2.5 ¹⁾	Brake Bleeder, Stierius	Bodo Stier
521-1021 ²⁾	Brake Bleeder, Mouse	Romess-Rogg

Note:

Both items are available via the MBUSA Standard Service Equipment Program (SSEP) at 1-888-458-4040.

¹⁾ This item was released and automatically delivered to all MBUSA dealers who did not procure the unit via the MBUSA Standard Service Equipment Program. As a Special Tool, this unit is identified with the MBUSA Special Tool Number: W 900 589 01 71 00.

²⁾ Added to SSEP Q2 2005.

Parts Information

Qty.	Part Name	Part Number
1	Suction hose	A 211 420 90 26 05
1	Suction hose (with double pulsation damper)	A 211 420 88 26 05
2	Hose clamps	A 001 997 69 90
1	SBC hydraulic unit	A 005 431 79 12 05
1	Ground wiring harness	A 211 440 35 08
3	Cable tie	A 001 997 83 90
1	Bracket	A 211 545 00 47 28
1	Guide bracket	A 211 546 74 43
1	Screw (self-tapping)	A 000 990 37 11
1	Interwoven adhesive tape ¹⁾	A 006 989 84 85 10
2.25 l	Brake fluid ²⁾	A 000 989 08 07 01
	(observe container size)	17 = (0.75 l)/18 = (5 l)

Note:

¹⁾ Submit as local purchase "TPE00013" quantity of 1. (handling is included).

²⁾ Submit as local purchase "BRAKEFL01653" quantity of 1. (handling is included).

Note:

- Please be aware that only the part number(s) referenced in the Campaign Bulletin is/are approved for use to repair the vehicle. Repairs performed using any other part(s) will not have been performed in accordance with the campaign. Accordingly, warranty claims submitted with reference to an improper part number(s) will be denied.
- The following allowable labor operation should be used when submitting a warranty claim for this repair:

Warranty Information (MODEL 211)**Repair 1 (Check hydraulic unit, mount ground wire and bracket)**

Operation: Diagnosis assistance system (DAS), connect & disconnect (02-4762)

SBC hydraulic unit – number range, check (02-4821)

Ground wire & bracket-SBC wiring harness, install (02-4846)

Damage Code	Operation Number	Labor Time (hrs.)	Model Indicator(s)
43 911 01 7	02-4762	0.2 hrs.	T1, T2, T3, T4, T5, T6, U1, U3, U4
	02-4821	0.1 hrs.	T1, T2, T3, T4, T5, T6, U1, U3, U4
	02-4846	0.4 hrs.	T1, T2, T3, T4, T5, T6, U1, U3, U4

Repair 2 (Check hydraulic unit, mount ground wire and bracket, perform software update)

Operation: Diagnosis assistance system (DAS), connect & disconnect (02-4762)

SBC hydraulic unit – number range, check (02-4821)

Ground wire & bracket-SBC wiring harness, install (02-4846)

Software - (DAS connected), install (02-4886)

Damage Code	Operation Number	Labor Time (hrs.)	Model Indicator(s)
43 911 01 7	02-4762	0.2 hrs.	T1, T2, T3, T4, T5, T6, U1, U3, U4
	02-4821	0.1 hrs.	T1, T2, T3, T4, T5, T6, U1, U3, U4
	02-4846	0.4 hrs.	T1, T2, T3, T4, T5, T6, U1, U3, U4
	02-4886	0.4 hrs.	T1, T2, T3, T4, T5, T6, U1, U3, U4

Repair 3 (Check, replace hydraulic unit, mount ground wire and bracket, replace suction hose)

Operation: Diagnosis assistance system (DAS), connect & disconnect (02-4762)

SBC hydraulic unit – number range, check (02-4821)

SBC hydraulic unit (DAS connected), replace (02-4822)

(Note: 02-4822 Includes suction hose replacement)

Ground wire&bracket-SBC wire harn.(hyd.unit rem.),mount (02-4831)

Damage Code	Operation Number	Labor Time (hrs.)	Model Indicator(s)
43 911 01 7	02-4762	0.2 hrs.	T1, T2, T3, T4, T5, T6, U1, U3, U4
	02-4821	0.1 hrs.	T1, T2, T3, T4, T5, T6, U1, U3, U4
	02-4822	2.8 hrs.	T1, T2, T4, T5, T6, U1, U3, U4
	02-4822	2.9 hrs.	T3
	02-4831	0.3 hrs.	T1, T2, T3, T4, T5, T6, U1, U3, U4

Repair 4 (Check, replace hydraulic unit, mount ground wire and bracket, replace suction hose, perform software update)

Operation: Diagnosis assistance system (DAS), connect & disconnect (02-4762)
 SBC hydraulic unit – number range, check (02-4821)
 SBC hydraulic unit (DAS connected), replace (02-4822)
 (Note: 02-4822 Includes suction hose replacement)
 Ground wire&bracket-SBC wire harn.(hyd.unit rem.),mount (02-4831)
 Software - (DAS connected), install (02-4886)

Damage Code	Operation Number	Labor Time (hrs.)	Model Indicator(s)
43 911 01 7	02-4762	0.2 hrs.	T1, T2, T3, T4, T5, T6, U1, U3, U4
	02-4821	0.1 hrs.	T1, T2, T3, T4, T5, T6, U1, U3, U4
	02-4822	2.8 hrs.	T1, T2, T4, T5, T6, U1, U3, U4
	02-4822	2.9 hrs.	T3
	02-4831	0.3 hrs.	T1, T2, T3, T4, T5, T6, U1, U3, U4
	02-4886	0.4 hrs.	T1, T2, T3, T4, T5, T6, U1, U3, U4

NOTE:

All replaced SBC hydraulic units **must** be returned to the Quality Evaluation Center (QEC) as indicated by NetStar parts disposition.

NOTE REGARDING CUSTOMER REIMBURSEMENT

Reimbursement to customers for repairs performed prior to this recall:

If the customer already paid to have this recall campaign condition repaired and provides adequate documentation to support their claim of a non-warranty repair of this item, they may be eligible to receive reimbursement.

Requests for reimbursement may include parts, labor, fees and taxes.

Reimbursement is limited to the amount the repair of the SBC hydraulic Unit, suction hose, ground wire and bracket, and related parts associated to these replacements (ex. screws, clamps, brake fluid) would have cost if completed by an authorized Mercedes-Benz dealer under this campaign.

Submit a warranty claim, utilizing Damage Code 43911018 as a sublet, utilizing the sublet code of "SUB." Sublet repairs require dealer text as stated in the Warranty Policies and Procedures Manual. Repair date should be the date that the customer paid for the repair.

Note:

Please note the claim submitted for customer reimbursement will **not** close the campaign (if still open).If the customer is still in possession of the vehicle with an open campaign, please arrange to close the campaign in the usual manner as described in this bulletin.

**II MODEL 230
INSPECT SBC HYDRAULIC UNIT, REPLACE AS DIRECTED**

Procedure

A. INSPECTION OF SBC HYDRAULIC UNIT

1. Check if SBC hydraulic unit part number (A, Figure 1) is listed in the table below:
 - If the part number (A) is **not** listed, proceed to step 3.
 - If the part number (A) is listed, proceed to step 2.

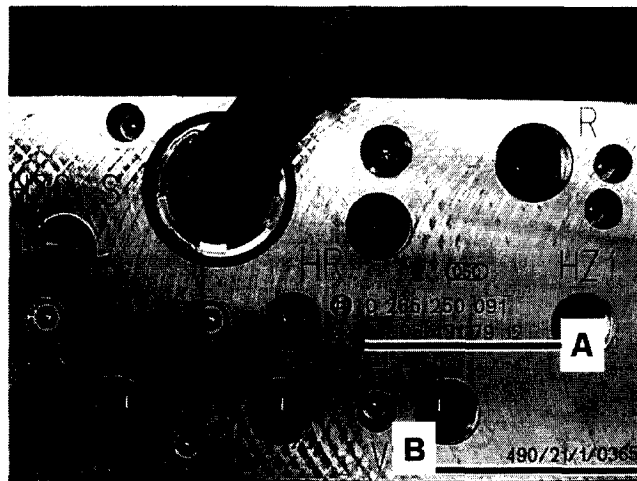

Figure 1

2. Check (refer to table below) if the production number (B, Figure 1) is within the listed production number range for the relevant part number (A):
 - If the production number (B) is **not** within the production number range, proceed to step 3.
 - If the production number (B) is within the production number range compared to the relevant part number; proceed to Subject B, Replacement of SBC Hydraulic unit.
(E.g., for SBC hydraulic unit part number: A 005 431 68 12. The production number 392/08/1/0500 is not within the number range - campaign completed. The production number 392/11/1/0700 is within the number range – proceed to Subject B, Replacement of SBC Hydraulic unit).
3. Do **not** replace SBC Hydraulic unit. Only perform the replacement of the suction hose, and the installation of ground wires and bracket to the SBC wiring harness. Proceed to Subject B and perform the following steps **only**: 1-6, 8-19, 22-27, 29-30.

Table

Part number	Production number	
	From	To
A 005 431 68 12	392/09/1/0496	392/12/1/0641
A 005 431 05 12	391/24/1/0680	481/08/1/0290
A 004 431 82 12	392/10/1/0244	392/18/1/1198
A 005 431 06 12	392/01/1/1152	481/08/1/0165
A 004 431 83 12	392/08/1/0525	392/08/1/0534

Note:

When reading the production number (B, Figure 1) on the SBC hydraulic pump, disregard the slashes. The production number should be read as a whole number:
e.g., 392/08/1/0534 = 3,920,810,534

B. REPLACEMENT OF SBC HYDRAULIC UNIT (MODEL 230)

WARNING!

Risk of injury caused by body parts being pinched or crushed. Risk of injury to skin and eyes caused by brake fluid spraying out at high pressure when working on the SBC brake system

Risk of poisoning from swallowing brake fluid.

Pour brake fluid only into suitable and appropriately marked containers. Wear protective clothing and eye protection when handling brake fluid.

1. Deactivate SBC system using Star Diagnosis (DAS).
2. Remove intake duct (arrow, Figure 2) on right side of engine.

Note:

For models with 12 cylinder engines also remove right air cleaner, refer to WIS: AR09.10-P-1150LA.

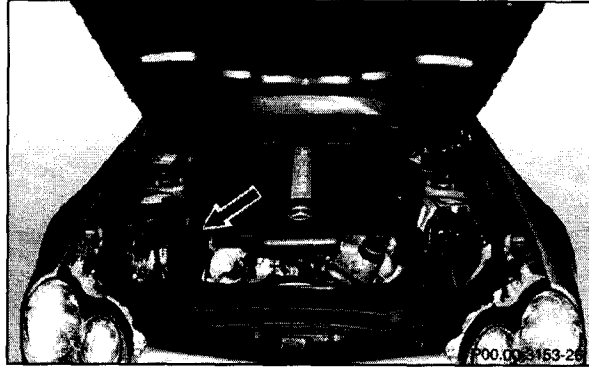

Figure 2

3. Disconnect SBC hydraulic unit harness connector (arrow, Figure 2a) from SBC hydraulic unit (A) and remove cable tie (B, Figure 3).

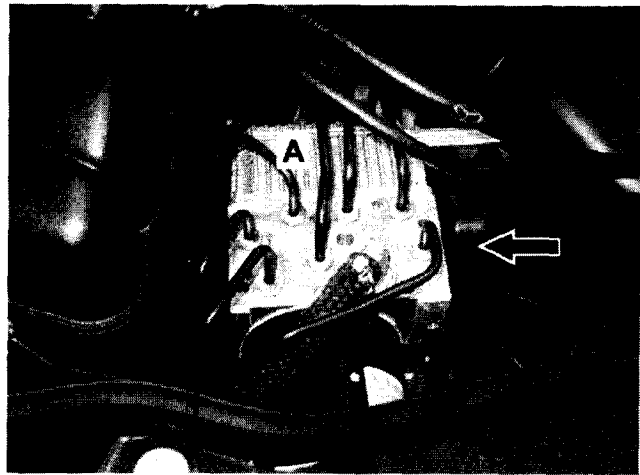

Figure 2a

4. Detach the SBC hydraulic unit ground wire harness (arrow, Figure 3) at ground terminal stud (A).
5. Position SBC harness connector (arrow, Figure 2a) away from SBC hydraulic lines to prevent brake fluid from dripping on SBC harness connector and SBC wiring harness.

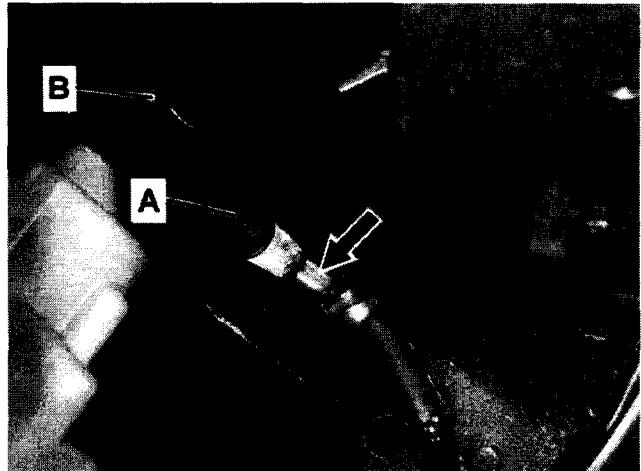

Figure 3

6. Remove omega (arrows, Figure 4) hose clips from SBC hydraulic unit bracket (A).
7. Remove SBC hydraulic unit refer to WIS: AR42.46-P-0010R, steps 1 - 11.

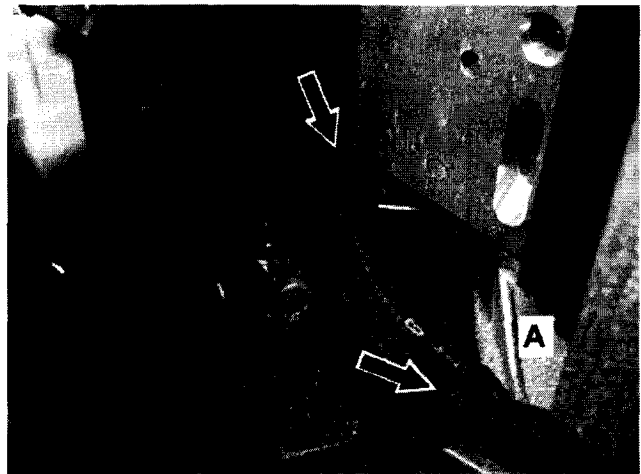

Figure 4

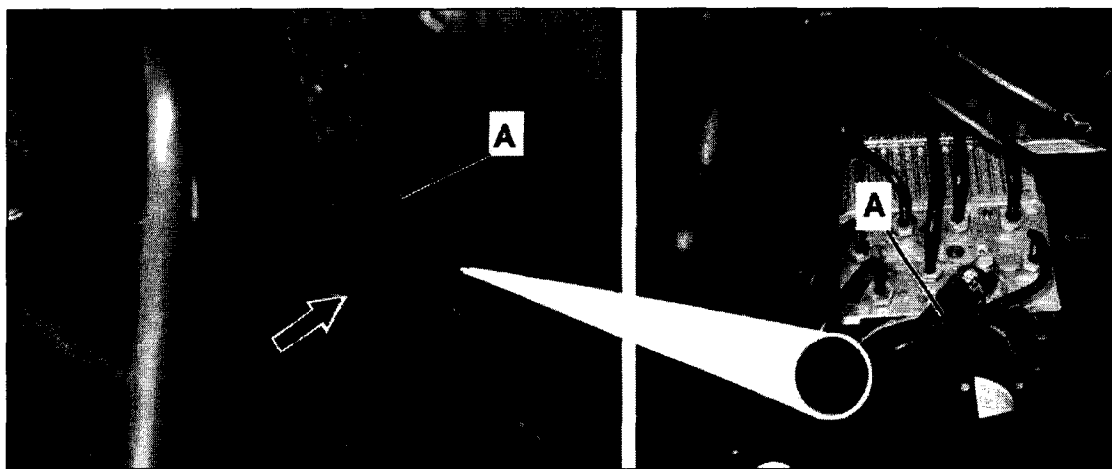

Figure 5

8. Replace suction hose (A, Figure 5):
 - Open the suction hose mounting clip (arrow) and remove suction hose (A) from bracket.
 - Remove mounting clip (arrow) from threaded stud and discard.

- Remove hose clamp (A, Figure 6) then remove suction hose (arrow) from suction line (B) using a plastic wedge (Example: Special Tool: W110 589 03 59 00).

⚠ CAUTION!

- Do not use sharp-edged tools (e.g., screwdriver) to remove suction hose (arrows, Figure 6) from suction line (B), as this may cause damage to the SBC brake system.

Note:

- When removing suction hose (arrow), do not bend suction line (B).
- To prevent brake fluid from running out and to prevent contamination in the brake system, the suction hose (arrows, Figure 6) and line (B) are to be plugged using suitable plugs from the stop plug kit (Special Tool: W129 589 00 91 00).
- Discard old suction hose (arrow) and clamp (A) after removal.

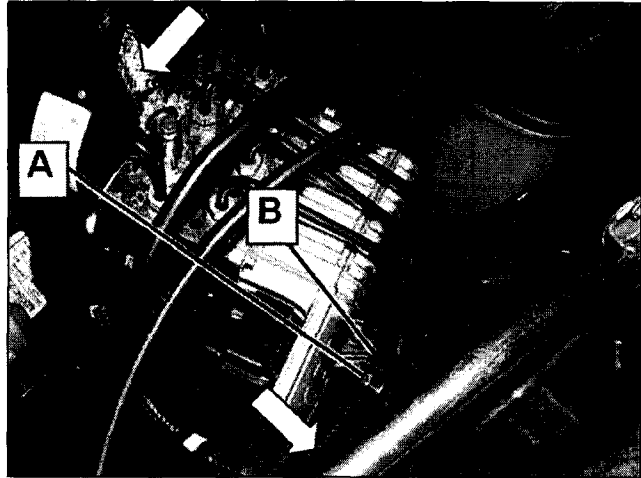

Figure 6 (Shown with SBC hydraulic unit installed)

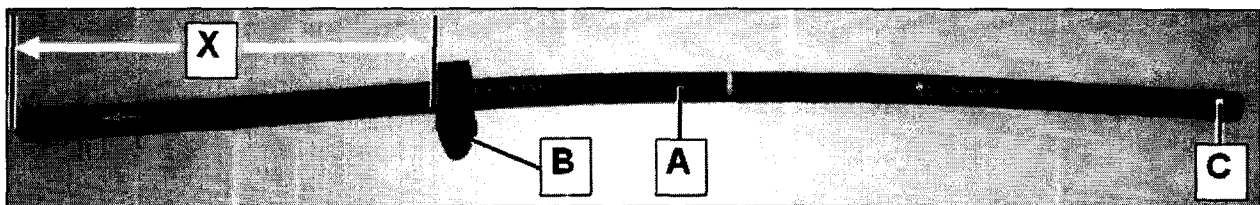

Figure 7 Dimension X = 20 cm

- Verify that the dimension X (Figure 7) on the **new** SBC suction hose (A) equals 20 cm. Adjust (if necessary) by repositioning the mounting clip (B) on the SBC suction hose (A).
- Place new hose clamp onto unmarked side of suction hose (C, Figure 7).
- Connect the unmarked end of the suction hose (C, Figure 7) onto the suction line (A Figure 8) and secure hose with a **new** hose clamp (arrow, Figure 8).

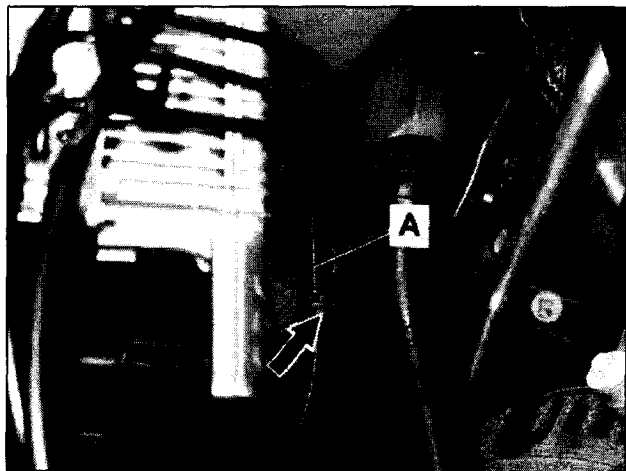

Figure 8

- Install the new SBC suction hose mounting clip (arrow, Figure 9) onto the mounting stud.

Note:

To gain better access to mounting clip (during installation); remove the plastic cover over the right head lamp; then tap the bracket into place using a socket extension and plastic mallet.

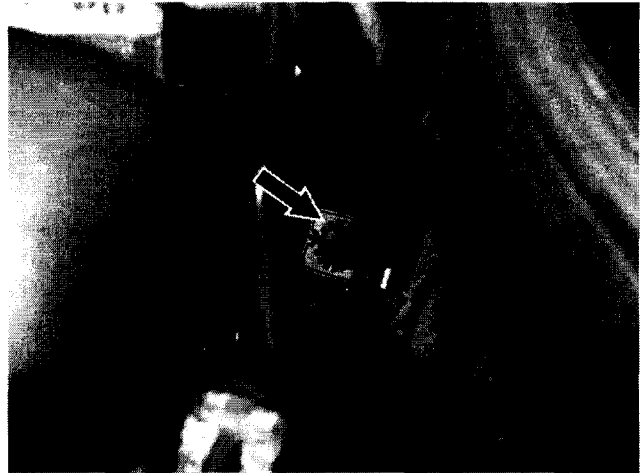

Figure 9

9. Remove cable tie (arrow, Figure 10) securing SBC wire harness (A) to SBC connector housing (B).

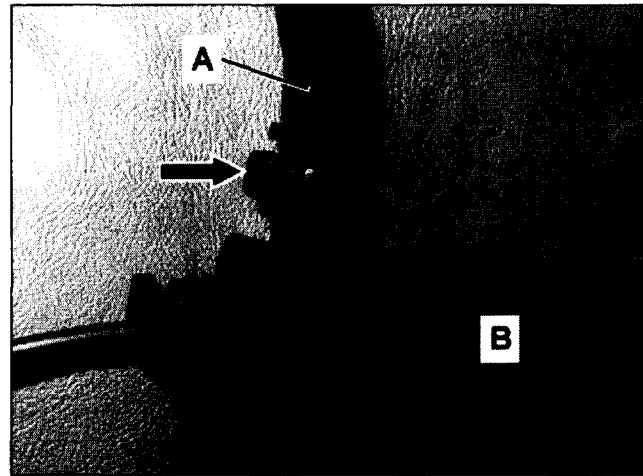

Figure 10

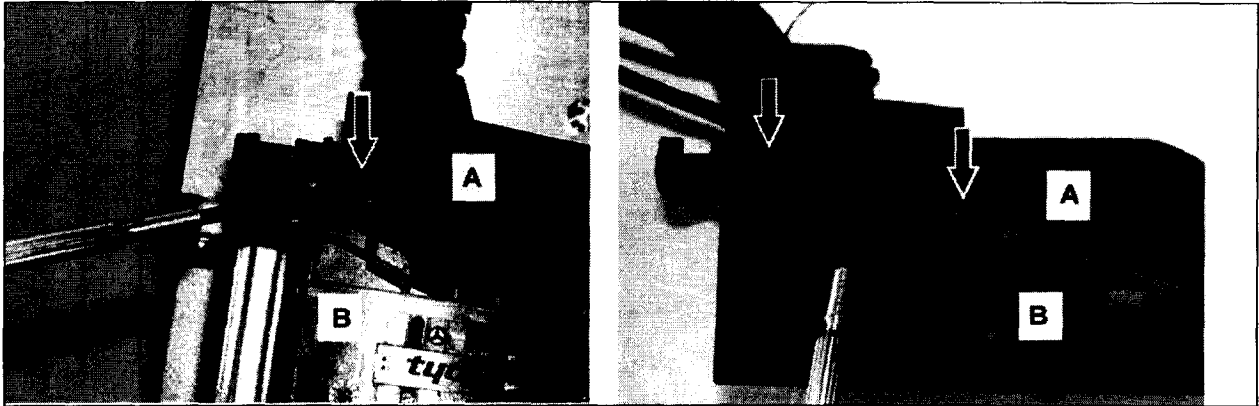

Figure 11

10. Remove SBC connector housing cover (A, Figure 11):

- Using a small screw driver, carefully pry cover (A) away from locking lugs (arrows) until cover (A) disengages.
- Repeat the process on opposite side.
- Remove the cover (A) from the housing (B).

Note:

There are two different versions of the SBC wiring harness connector (Figures 12 a, b) installed in vehicles involved with this campaign.



Figure 12a

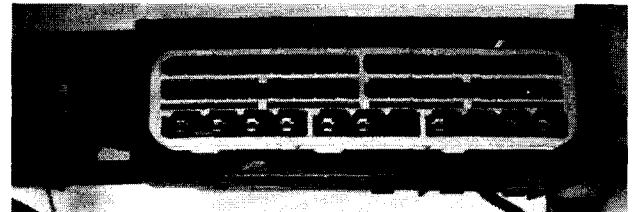

Figure 12b

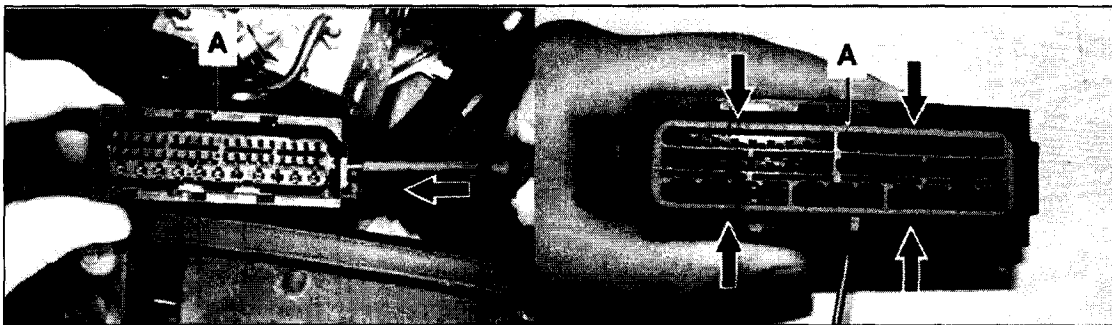

Figure 13a (Connector Type A)

Figure 13b (Connector Type B)

11. Open (gray) secondary lock in the SBC connector housing (A, Figure 13):

Connector Type A:

Slide the secondary lock in the direction indicated by the arrow (Figure 13a) using a small screwdriver to release lock.

Connector Type B:

Pry upwards using a small screwdriver as indicated by arrow (Figure 13b) to disengage the secondary lock.

12. Remove cable tie (arrow, Figure 14) securing ground wires (A) to SBC connector housing (B).

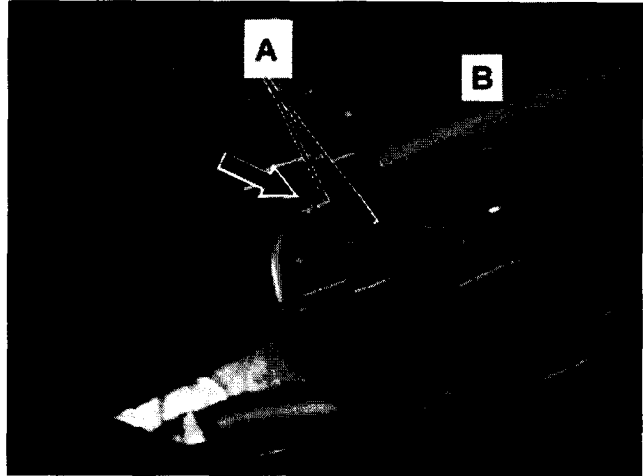

Figure 14

13. Remove SBC ground wires (arrows, Figure 15) from SBC harness connector (A):
- Unpin SBC ground wire connectors (position 37 and 44) using cable release (Special Tools: W 000 589 13 99 30 and W 220 589 01 99 50) and remove ground wires (arrows) from SBC connector housing (A).
 - Discard old ground wire harness, it is no longer needed.
14. Insert the new ground wire harness (arrows Figure 15) into the SBC connector housing (A):
- Insert **longer** ground wire into position 44.
 - Insert **shorter** ground wire into position 37.

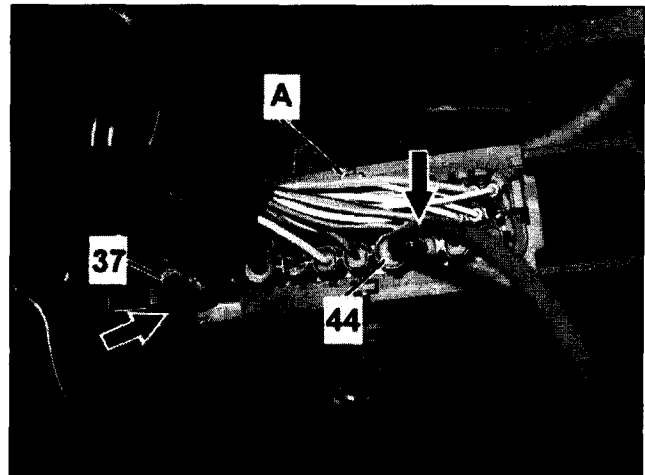

Figure 15

Note:

Ensure ground wire connectors are **properly** locked into place.

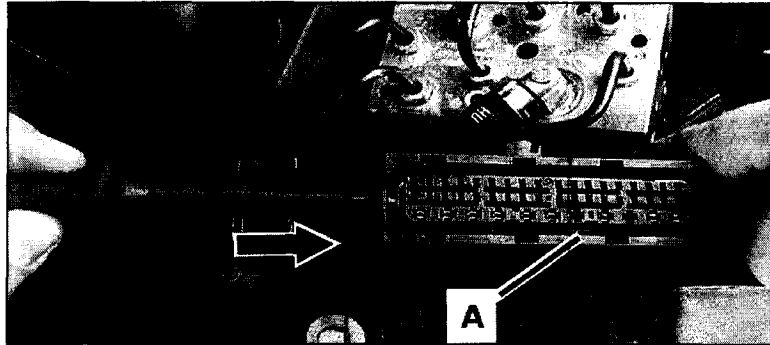

Figure 16a (Connector Type A)

15. Close the (gray) secondary lock of the SBC connector housing (A, Figure 16):

Connector Type A:

Slide the secondary lock in the direction indicated by the arrow (Figure 16) using a small screwdriver until it locks into place.

Connector Type B:

Place secondary lock on top of connector and snap back into place.

16. Reinstall connector cover (A, Figure 11) in reverse order.

17. Secure SBC wiring harness (A, Figure 17) (excluding ground wires) to the SBC connector cover receptacle (arrow) using a new cable tie (B).

Note:

- Ensure that the SBC wiring harness (A) is properly routed so that it is free of tension in the SBC connector housing.
- The cable tie "buckle" (D) **must be located at the side of the connector cover receptacle (arrow) as depicted.**

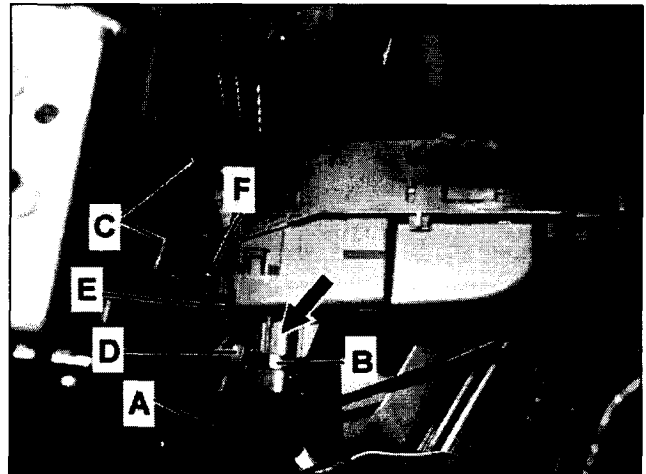

Figure 17

18. Secure ground wiring harness (C) to the SBC connector housing receptacle (F) using a new cable tie (E).

19. Attach bracket (A, Figure 18) to the SBC hydraulic unit:

- Using hand tools, tap threads into SBC hydraulic unit bores by running self tapping screw (arrow) into lower bore **without** mounting bracket positioned on SBC unit.

Note:

- In order to avoid breaking the M5 self-tapping screw (arrow) during installation, the screw (arrow) must be **positioned absolutely straight**
- Do not use power tools to install self tapping screw.

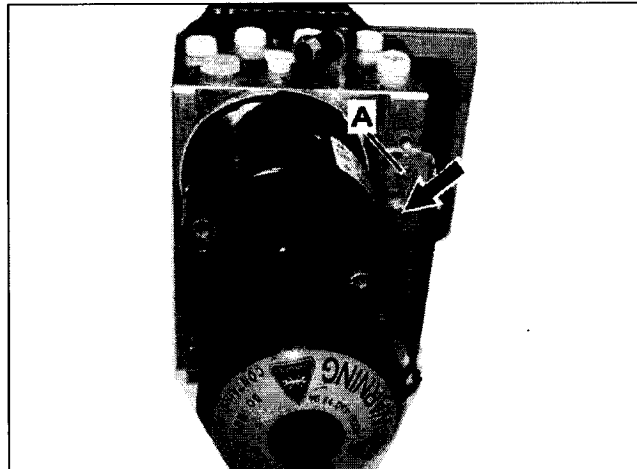

Figure 18

- Remove self tapping screw (arrow).
- Position bracket (A) on SBC hydraulic unit, reinstall self tapping screw (arrow) and **torque to 7 Nm**.

20. Install new SBC hydraulic unit into SBC body mounting grommets.

21. Connect hydraulic lines to SBC unit; refer also to WIS: AR42.46-P-0010R steps 12 – 16.

22. Connect SBC suction hose (A, Figure 19) to SBC hydraulic unit fitting (B); refer also to WIS: AR42.46-P-0010R steps 12 – 16.

Note:

Ensure new hose clamp (arrow) is installed.

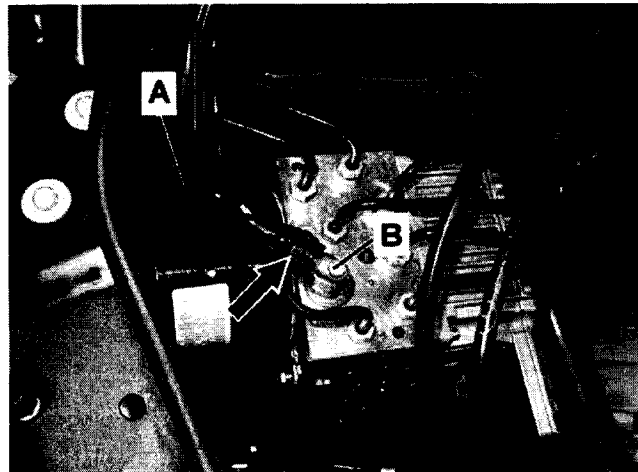

Figure 19

23. Secure new SBC suction hose (A, Figure 20) to SBC hydraulic unit mounting bracket (B) using **new** ("omega" type) mounting clips (arrows).

24. Insert a cable tie through slots (C, Figure 20) in bracket (D), **do not** close cable tie

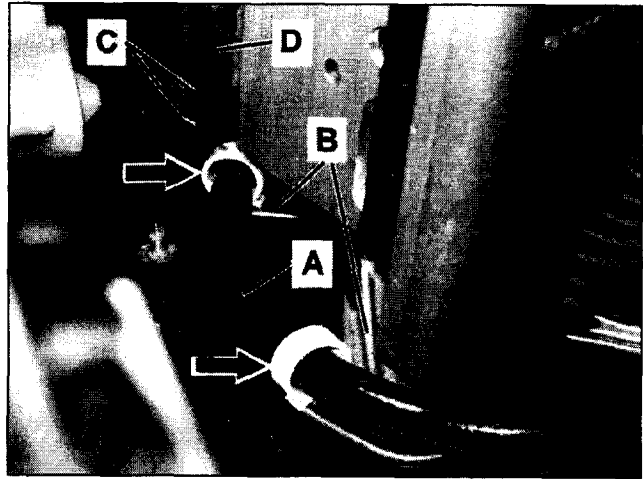

Figure 20

25. Connect SBC harness connector (A, Figure 21) to SBC hydraulic unit and secure by engaging locking mechanism.

26. Secure SBC wiring harness (B, Figure 21) to SBC hydraulic unit bracket (C) with cable tie (arrow). Torque cable tie (arrow) using cable tie pliers (Special Tool W 352 589 02 37 00) to **150 - 170 Nm** (use torque setting 4 on cable tie pliers).

Note

- The cable tie buckle (D) must not touch the bracket (C).
- When attaching SBC wire harness (B) to the bracket (C), ensure that the wire harness (B) touches the bracket (C) and is mounted there tension free.
- After the SBC wire harness (B) is secured, it must not be able to move in the longitudinal direction toward the bracket.

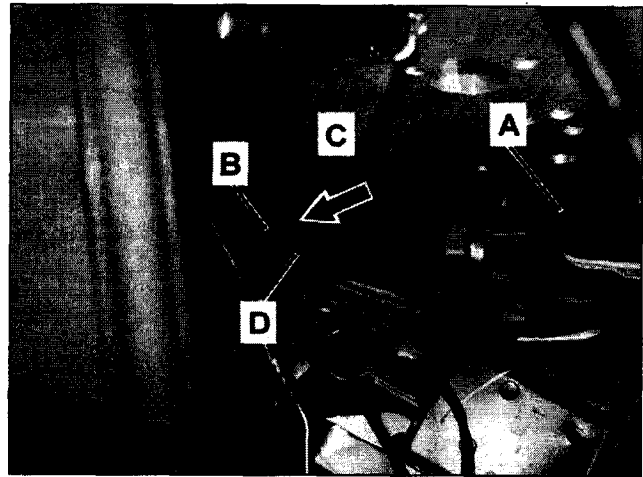
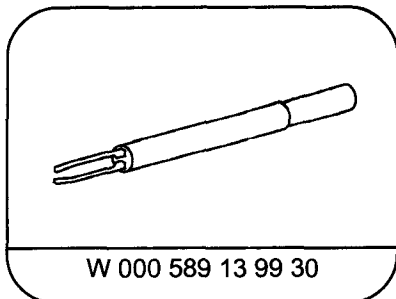

Figure 21

27. Attach the ground wire harness ring connector (A, Figure 22) to the body ground terminal (B) with M6 nut. Torque the M6 nut to 10 Nm.

Note:

- The ground wire harness (arrow) must be routed under the SBC suction hose (C). The ring connector (A) **must** be positioned as shown in Figure 22.

Special Tools

W 000 589 13 99 30

Blade

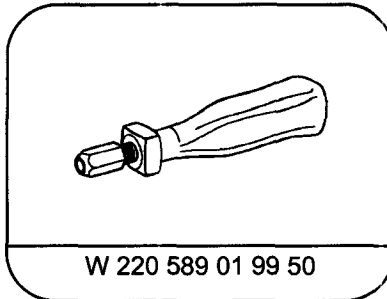

W 220 589 01 99 50

Handle

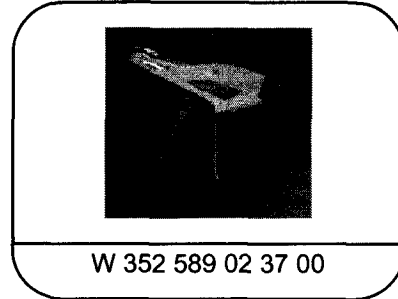

W 352 589 02 37 00

Cable tie pliers

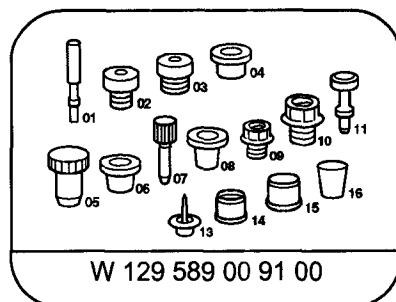

W 129 589 00 91 00

Stop Plug Kit

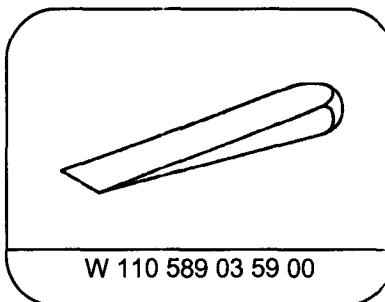

W 110 589 03 59 00

Plastic Wedge

Special Tools Information

Special Tool Number	Group/ Category	Description	Dir Net
W 000 589 13 99 30 ¹⁾	00/ B	Blade; MCP/ JPT/ SPT	\$ 41.00
W 220 589 01 99 50 ¹⁾	00/ B	Blade Holder	\$ 9.00
W 352 589 02 37 00 ²⁾	54/ C	Tension Tool; Cable Tie	\$ 296.00
W 129 589 00 91 00 ³⁾	77/ K	Plug Set; Hydraulic	\$ 98.00
W 110 589 03 59 00 ⁴⁾	72/ K	Mounting Wedge	\$ 19.50

Note:

¹⁾ Special Tool W 000 589 13 99 30 is interchangeable with W 220 589 01 99 61. Special Tool W 000 589 13 99 30 is the latest replacement for an existing Special Tool W 220 589 01 99 61, released and automatically delivered to all MBUSA dealers in the Wiring Harness Repair Kit: Special Tool W 220 589 01 99 00 (and later as W 220 589 02 99 00).

²⁾ Special Tool W 352 589 02 37 00 will be released and automatically delivered to each MBUSA dealer.

³⁾ This required Special Tool should already be in stock at each MBUSA dealer location.

⁴⁾ This is a sample Special Tool number provided for your reference.

Required Equipment Information

Equipment Part Number	Description	MFR.
275-ST-BBE-2.5 ¹⁾	Brake Bleeder, Stierius	Bodo Stier
521-1021 ²⁾	Brake Bleeder, Mouse	Romess-Rogg

Note:

Both items are available via the MBUSA Standard Service Equipment Program (SSEP) at 1-888-458-4040.

¹⁾ This item was released and automatically delivered to all MBUSA dealers who did not procure the unit via the MBUSA Standard Service Equipment Program. As a Special Tool, this unit is identified with the MBUSA Special Tool Number: W 900 589 01 71 00.

²⁾ Added to SSEP Q2 2005.

Parts Information

Qty.	Part Name	Part Number
1	Suction hose	A230 420 04 48 05
2	Hose clamp	A001 997 69 90
2	Cable clamp (Omega attachment clip)	A000 995 52 44
1	SBC hydraulic unit	A005 431 79 12 05
1	Ground wiring harness	A230 540 92 10 05
3	Cable tie	A 001 997 83 90
1	Bracket	A230 545 00 47 05
1	Screw (self-tapping)	N 007516 005106
2.25 l	Brake fluid ¹⁾ (observe container size)	A 000 989 08 07 01 17 = (0.75 l)/18 = (5 l)

Note:

¹⁾ Submit as local purchase "BRAKEFL01653" quantity of 1. (handling is included).

Note:

- Please be aware that only the part number(s) referenced in the Campaign Bulletin is/are approved for use to repair the vehicle. Repairs performed using any other part(s) will not have been performed in accordance with the campaign. Accordingly, warranty claims submitted with reference to an improper part number(s) will be denied.
- The following allowable labor operation should be used when submitting a warranty claim for this repair:

Warranty Information (MODEL 230)**Repair 1 (Check hydraulic unit, mount ground wire and bracket, replace suction hose)**

Operation: Diagnosis assistance system (DAS), connect & disconnect (02-4762)
 SBC hydraulic unit – number range, check (02-4821)
 Suction line-SBC system (DAS connected), replace (02-4845)
 Ground wire & bracket-SBC wiring harness, install (02-4846)

Damage Code	Operation Number	Labor Time (hrs.)	Model Indicator(s)
43 911 01 7	02-4762	0.2 hrs.	R1, R2, R3
	02-4821	0.1 hrs.	R1, R2, R3
	02-4845	2.3 hrs.	R1
	02-4845	2.4 hrs.	R2, R3
	02-4846	0.4 hrs.	R1, R2, R3

Repair 2 (Check hydraulic unit, mount ground wire and bracket, replace suction hose, perform software update)

Operation: Diagnosis assistance system (DAS), connect & disconnect (02-4762)
 SBC hydraulic unit – number range, check (02-4821)
 Suction line-SBC system (DAS connected), replace (02-4845)
 Ground wire & bracket-SBC wiring harness, install (02-4846)
 Software – (DAS connected), install (02-4886)

Damage Code	Operation Number	Labor Time (hrs.)	Model Indicator(s)
43 911 01 7	02-4762	0.2 hrs.	R1, R2, R3
	02-4821	0.1 hrs.	R1, R2, R3
	02-4845	2.3 hrs.	R1
	02-4845	2.4 hrs.	R2, R3
	02-4846	0.4 hrs.	R1, R2, R3
	02-4886	0.4 hrs.	R1, R2, R3

Repair 3 (Check, replace hydraulic unit, mount ground wire and bracket, replace suction hose)

Operation: Diagnosis assistance system (DAS), connect & disconnect (02-4762)
 SBC hydraulic unit – number range, check (02-4821)
 SBC hydraulic unit (DAS connected), replace (02-4822)
 (**Note:** 02-4822 Includes suction hose replacement)
 Ground wire&bracket-SBC wire harn.(hyd.unit rem.),mount (02-4831)

Damage Code	Operation Number	Labor Time (hrs.)	Model Indicator(s)
43 911 01 7	02-4762	0.2 hrs.	R1, R2, R3
	02-4821	0.1 hrs.	R1, R2, R3
	02-4822	3.3 hrs.	R1
	02-4822	3.4 hrs.	R2, R3
	02-4831	0.3 hrs.	R1, R2, R3

Repair 4 (Check, replace hydraulic unit, mount ground wire and bracket, replace suction hose, perform software update)

Operation: Diagnosis assistance system (DAS), connect & disconnect (02-4762)
 SBC hydraulic unit – number range, check (02-4821)
 SBC hydraulic unit (DAS connected), replace (02-4822)
 (Note: 02-4822 Includes suction hose replacement)
 Ground wire&bracket-SBC wire harn.(hyd.unit rem.),mount (02-4831)
 Software – (DAS connected), install (02-4886)

Damage Code	Operation Number	Labor Time (hrs.)	Model Indicator(s)
43 911 01 7	02-4762	0.2 hrs.	R1, R2, R3
	02-4821	0.1 hrs.	R1, R2, R3
	02-4822	3.3 hrs.	R1
	02-4822	3.4 hrs.	R2, R3
	02-4831	0.3 hrs.	R1, R2, R3
	02-4886	0.4 hrs.	R1, R2, R3

NOTE:

All replaced SBC hydraulic units **must** be returned to the Quality Evaluation Center (QEC) as indicated by NetStar parts disposition.

NOTE REGARDING CUSTOMER REIMBURSEMENT

Reimbursement to customers for repairs performed prior to this recall:

If the customer already paid to have this recall campaign condition repaired and provides adequate documentation to support their claim of a non-warranty repair of this item, they may be eligible to receive reimbursement.

Requests for reimbursement may include parts, labor, fees and taxes.

Reimbursement is limited to the amount the repair of the SBC hydraulic Unit, suction hose, ground wire and bracket, and related parts associated to these replacements (ex. screws, clamps, brake fluid) would have cost if completed by an authorized Mercedes-Benz dealer under this campaign.

Submit a warranty claim, utilizing Damage Code 43911018 as a sublet, utilizing the sublet code of "SUB." Sublet repairs require dealer text as stated in the Warranty Policies and Procedures Manual. Repair date should be the date that the customer paid for the repair.

Note:

Please note the claim submitted for customer reimbursement will **not** close the campaign (if still open).If the customer is still in possession of the vehicle with an open campaign, please arrange to close the campaign in the usual manner as described in this bulletin.

Safety Recall #2005070007

August, 2005

Dear Mercedes-Benz Owner

This notice is sent to you in accordance with the requirements of the National Traffic and Motor Vehicle Safety Act. WE SENT YOU THIS NOTICE BECAUSE WE ARE CONCERNED ABOUT YOUR SAFETY.

DaimlerChrysler AG (DCAG), the manufacturer of Mercedes-Benz vehicles, has decided that a defect which relates to motor vehicle safety exists in certain Model Year 2004 E-Class and SL-Class vehicles equipped with Sensotronic Brake Control (SBC). Mercedes-Benz USA, LLC (MBUSA) therefore has initiated a recall of these vehicles. Our records indicate that your vehicle is included in the affected population of vehicles.

The SBC brake system in certain E-Class and SL-Class vehicles, in certain instances, may prematurely shift to the hydraulic back up mode due to a loosening of the ground wire harness connection over time, or due to premature failure of the hydraulic pump. In the hydraulic back up mode, the driver has braking power sufficient to stop the vehicle, although greater brake pedal pressure is required and the brake pedal travel will be noticeably longer which could lead to a vehicle crash.

Your authorized Mercedes-Benz dealer has available a bracket and replacement ground wire that it will install on your vehicle's SBC pump unit to correct the situation described above by preventing loosening of the new ground wire harness connection. Additionally dealers will check a production date range on the SBC hydraulic pump and if required replace the pump. This service will be provided free of charge. The working time required is approximately 4 hours. Your authorized Mercedes-Benz dealer will also check for other needed repair measures applicable to your vehicle which may increase the required working time. Please contact your authorized Mercedes-Benz dealer for additional information and to schedule an appointment at your earliest convenience. Please mention Recall Campaign #2005 070007.

If you are no longer the vehicle owner, or have a change of address, please complete the reverse side of this letter and return the complete letter in the enclosed envelope. If this is a leased vehicle and the lessor and registered owner receive this notice, please forward this information by first class mail to the lessee. If you have paid to have this recall condition corrected prior to this notice you may be eligible to receive reimbursement. Please see the reverse side of this notice for details.

Please contact your authorized Mercedes-Benz dealer should you have any questions or encounter any difficulty regarding this recall. If your dealer is unable to remedy your situation please contact us at 1-(800) FOR-MERCEdes (1-800-367-6372).

If an authorized Mercedes-Benz dealer or Mercedes-Benz USA, LLC, fails or is unable to perform this service without charge within 60 days, pursuant to law 49 U.S.C. Chapter 301, you may submit a complaint to the Administrator, National Highway Traffic Safety Administration, 400 Seventh Street, S.W., Washington, D.C. 20590 or call the toll-free Auto Safety Hotline at 1-888-327-4236 (TTY 1-800-424-9153); or go to <http://www.safercar.gov>.

We apologize for any inconvenience this situation may cause you.

Sincerely

Klaus Ulkann
Vice President, Customer Services