

05V-118



# VEHICLE RECALL

## SC295

(Not applicable to Mack Trucks Australia)

**Date:** 05/05/05 (Supersedes SC295 dated 04/28/05)

**To:** All MACK Dealers

**Subject:** Steering Shaft Pinch Bolt Torque — CV, CT, RB and DM Models

### Information:

It has been determined that on certain CV, CT, RB and DM model chassis manufactured between December 10, 2004 and December 14, 2004, the steering shaft pinch bolts located at the bottom of the steering column inside the cab, and at the bottom of the intermediate steering shaft just before the bearing, may not have been tightened sufficiently at assembly. If the pinch bolts are loose, the steering shaft could separate while the vehicle is in operation, resulting in a loss of control. Approximately 115 CV, CT, RB and DM models are involved in this campaign. A list of affected vehicles has been sent to all applicable dealers.

### Procedures:

The steering shafts on all affected chassis must be inspected to ensure the pinch bolts are in place and tightened sufficiently.

### NOTE

Before proceeding, check campaign status in the MACKnet system to see if the campaign has already been completed. Campaign status can also be checked by looking at the Campaign Completion Label located on the lower edge of the passenger-side door. If the campaign has been completed, the campaign number (SC295) and the completion date should be written on the label.

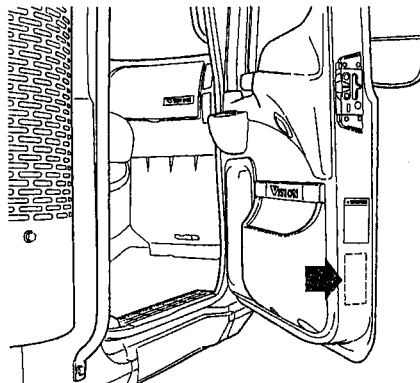

703153a

Figure 1 — Campaign Label Location

Torque specifications for the pinch bolts are as follows:

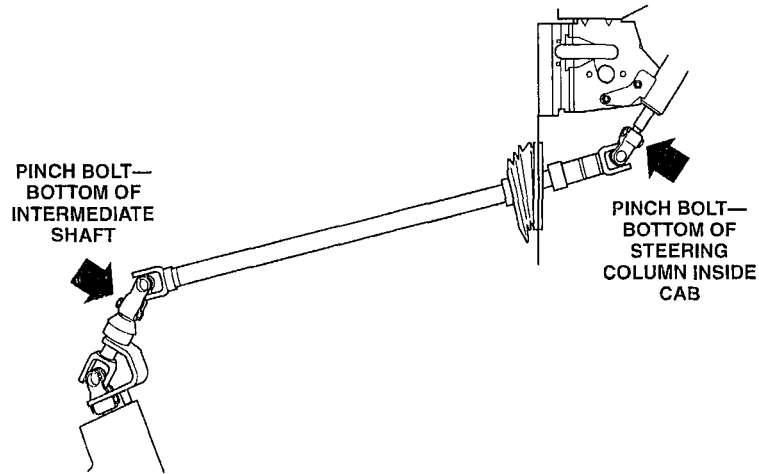

403597a

**Figure 2 — Steering Shaft Pinch Bolt Locations**



- 7/16" fastener (CV and CT models, upper and lower) — 65–75 lb-ft (88–102 N•m)
- 3/8" fastener (RB and DM models, upper and lower) — 45–50 lb-ft (61–68 N•m)

**NOTE**

Do not lubricate the pinch bolt threads.

Apply a yellow paint mark to the head of each pinch bolt to signify that the campaign has been completed.

If pinch bolts are damaged or missing, part numbers for replacement fasteners are as follows:

Part No.	Description
3AX1812	Bolt, grade 8, 3/8-24 UNF x 2" long
21AX801	Nut, 3/8-24 UNF
3AX1876	Bolt, grade 8, 7/16-20 UNF x 2" long
21AX789	Nut, 7/16-20 UNF

## NOTE

To signify that the campaign has been completed, use a permanent-type marker (such as a Sharpie®) to write the campaign number (SC295) and completion date in the spaces provided on the Campaign Completion label located on the lower edge (below the door latch) of the passenger-side door. If a label is not already affixed to the door, apply a label (part No. TS897) and supply the information as required. Campaign Completion labels are available in packs of 50 and can be ordered by faxing a completed BR313 to Pacesetters Business Services at 610-264-9465.

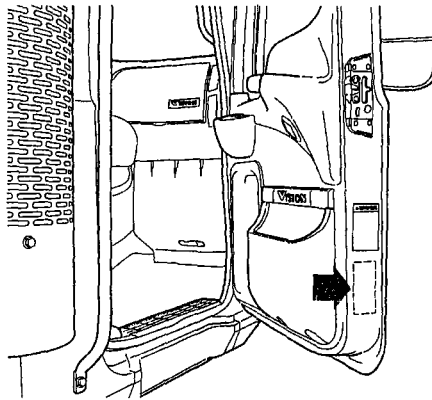

703153a

Figure 3 — Campaign Label Location

### Parts Required:

New pinch bolts and nuts are required only if the originals are missing. Refer to the table on page 2 for the fastener part numbers.

Order vehicle recall parts on a separate stock order and process through the parts distribution center normally serving your area. Do not include parts on this requisition that are not required for this recall campaign.

International orders are to be prefixed — V.O.R.

**Reimbursement:**

Campaign expenses are to be recovered through normal warranty claim procedures. Enter the following information on the warranty claim:

<b>UNDER</b>	<b>ENTER</b>	
Failed Part No.....	SC0295	
Labor Code/Allowance .....	412 3D AE 95 — 0.2 hr.	Time allowed to take charge of vehicle and check MACKnet system and campaign completion label to determine campaign status.
	412 3B ZE 95 — 0.3 hr.	Time allowed to check torque of fasteners at both steering shaft universal joints on CV, CT, RB and DM model vehicles. Does not include "take-charge" time.
	412 3C ZE 95 — 0.3 hr.	Time allowed to install pinch bolt as required and tighten to proper specifications at both steering shaft universal joints on CV, CT, RB and DM model vehicles. Does not include "take-charge" time.

**NOTE**

As required by Federal Motor Vehicle Safety Standards 49 CFR 573.11, no vehicle subject to an open safety campaign shall be delivered to the customer until such time as the defect or noncompliance is remedied.