



Recall Bulletin



FMVSS NONCOMPLIANCE RECALL

SUBJECT: REAR SEAT CHILD RESTRAINT ANCHORAGE OWNER MANUAL UPDATE

MODELS: 2005 PONTIAC G6

CONDITION

General Motors has decided that certain 2005 Pontiac G6 vehicles fail to conform to Federal Motor Vehicle Safety Standard 225 requirements for child restraint lower anchorage location and owner manual information for the rear center seat. Without additional owner manual information, an owner may encounter difficulty in installing child restraints with rigid attachments in the center position.

If difficulty is encountered when trying to secure a child restraint in the rear center seating position, the restraint should be moved to either outboard seating positions.

CORRECTION

An owner manual update will be sent to owners of record that describes the location and proper use of the anchorages in all three rear seating positions. Dealers are to place an update in the owner manual of vehicles in their inventory.

VEHICLES INVOLVED

Involved are **certain** 2005 Pontiac G6 vehicles built within these VIN breakpoints:

YEAR	DIVISION	MODEL	FROM	THROUGH
2005	Pontiac	G6	54106669	54154212

IMPORTANT: Dealers should confirm vehicle eligibility through **GMVIS** (GM Vehicle Inquiry System) prior to beginning recall repairs. [Not all vehicles within the above breakpoints may be involved.]

For dealers with involved vehicles, a Campaign Initiation Detail Report containing the complete Vehicle Identification Number, customer name and address data has been prepared and will be loaded to the GM DealerWorld, Recall Information website. Dealers that have no involved vehicles currently assigned will not have a report available in GM DealerWorld.

The Campaign Initiation Detail Report may contain customer names and addresses obtained from Motor Vehicle Registration Records. The use of such motor vehicle registration data for

any purpose other than follow-up necessary to complete this recall is a violation of law in several states/provinces/countries. Accordingly, you are urged to limit the use of this report to the follow-up necessary to complete this recall.

PARTS INFORMATION

No parts are required for this recall.

SERVICE PROCEDURE

1. Make a copy of the 6 page owner manual update found in this bulletin and place it in the owner manual.

This information replaces the information found in your owner manual under the headings *Where to Put the Restraint, Top Strap Anchor Location, Lower Anchorages and Top Tethers for Children (LATCH System), and Securing a Child Restraint Designed for the LATCH System.*

Where to Put the Restraint

Accident statistics show that children are safer if they are restrained in the rear rather than the front seat. General Motors recommends that child restraints be secured in a rear seat, including an infant riding in a rear-facing infant seat, a child riding in a forward-facing child seat and an older child riding in a booster seat.

Your vehicle has a rear seat that will accommodate a rear-facing child restraint. A label on your sun visor says, "Never put a rear-facing child seat in the front." This is because the risk to the rear-facing child is so great, if the airbag deploys.

Caution: A child in a rear-facing child restraint can be seriously injured or killed if the right front passenger's airbag inflates. This is because the back of the rear-facing child restraint would be very close to the inflating airbag.

Even though the passenger sensing system is designed to turn off the passenger's frontal airbag if the system detects a rear-facing child restraint, no system is fail-safe, and no one can guarantee that an airbag will not deploy under some unusual circumstance, even though it is turned off. General Motors recommends that rear-facing child restraints be secured in the rear seat, even if the airbag is off.

If you need to secure a forward-facing child restraint in the right front seat, always move the front passenger seat as far back as it will go. It is better to secure the child restraint in a rear seat.

If you need to secure more than one child restraint in the rear seat, review the following illustrations. Depending on where you place the child restraint, you may not be able to access certain safety belt assemblies or LATCH anchors for additional passengers or child restraints.

Configurations for Use of Child Restraints

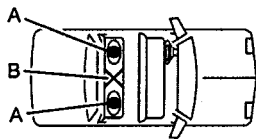

- A. Child restraint using LATCH
- B. Child restraint or occupant using safety belt

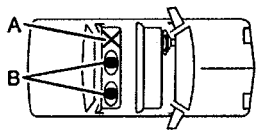

- A. Occupant prohibited
- B. Child restraint using LATCH

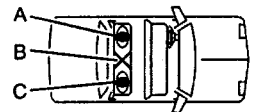

- A. Child restraint using LATCH
- B. Child restraint or occupant using safety belt
- C. Child restraint using safety belt or LATCH or occupant using safety belt

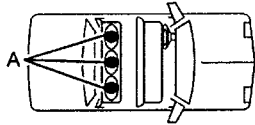

A. Child restraint or occupant using safety belt

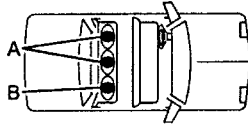

A. Child restraint or occupant using safety belt

B. Child restraint using LATCH

Wherever you install a child restraint, be sure to secure the child restraint properly.

Keep in mind that an unsecured child restraint can move around in a collision or sudden stop and injure people in the vehicle. Be sure to properly secure any child restraint in your vehicle — even when no child is in it.

Top Strap Anchor Location

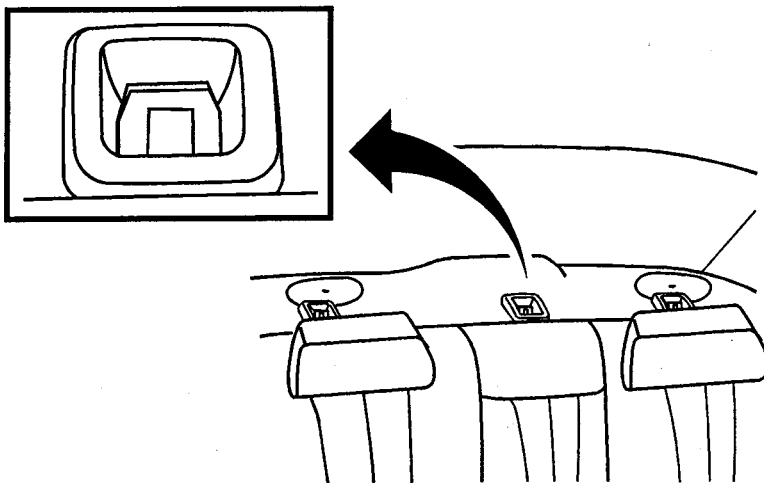

Your vehicle has top strap anchors for the rear seating positions. The anchors are located on the filler panel behind the rear seat head restraints.

If your vehicle has adjustable head restraints, pull up the head restraint to access the anchors. The straps from the child restraint must be threaded between the poles of the head restraint on the seat. The strap must not go around the head restraint.

Do not secure a child restraint in the right front passenger's position if a national or local law requires that the top strap be anchored, or if the instructions that come with the child restraint say that the top strap must be anchored. There is no place to anchor the top strap in this position.

Lower Anchorages and Top Tethers for Children (LATCH System)

Your vehicle has the LATCH system. There are anchors for all three rear seating positions. The anchors are located between the seatback and the seat cushion. There is a specific way to attach a child restraint to the anchors in the three possible positions.

If you need to secure more than one child restraint in the rear seat see *Where to Put the Restraint*. Depending on where you place the child restraint, you may not be able to access certain safety belt assemblies or LATCH anchors for additional passengers or child restraints.

You cannot secure three child restraints using the LATCH anchors in the rear seat at the same time, but you can install two of them. If you want to do this, install one LATCH child restraint in the passenger-side position, and install the other one either in the driver's-side position or in the center position. Refer to the following illustration to learn which anchors to use.

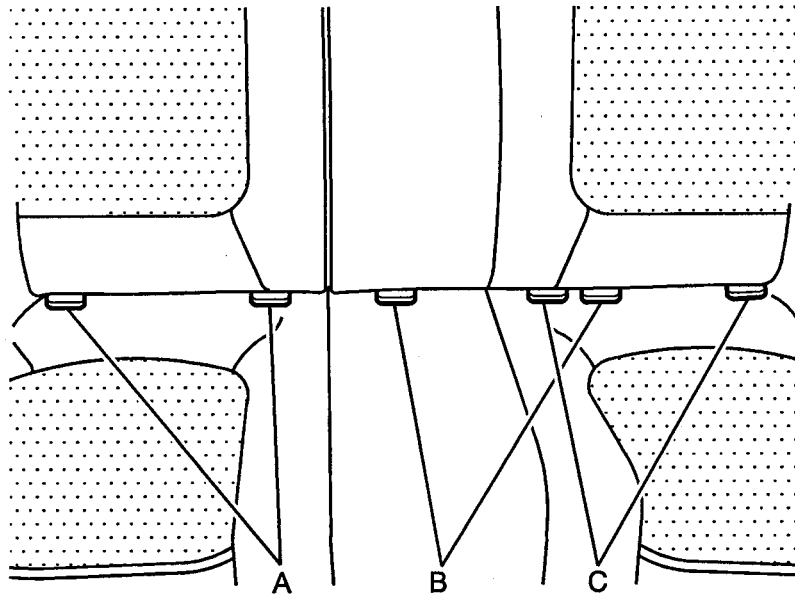

- A. Passenger's-side Rear Seat Lower Anchorages
- B. Center Rear Seat Lower Anchorages
- C. Driver's-side Rear Seat Lower Anchorages

Make sure to attach the child restraint at the proper anchor location.

This system, designed to make installation of child restraints easier, does not use the vehicle's safety belts. Instead, it uses vehicle anchors and child restraint attachments to secure the restraints. Some restraints also use another vehicle anchor to secure a top strap.

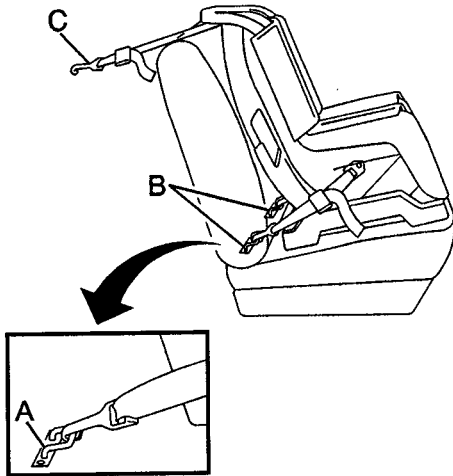

- A. Lower Anchorage
- B. Lower Anchorage
- C. Top Strap

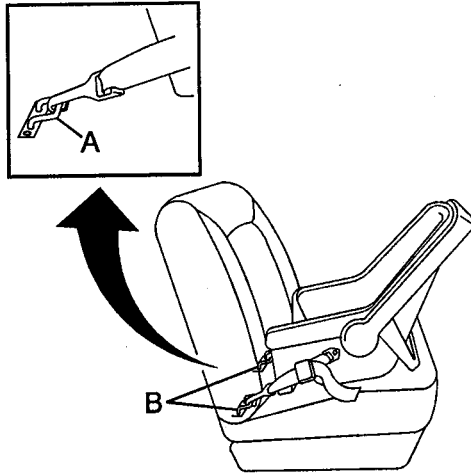

- A. Lower Anchorage
- B. Lower Anchorage

In order to use the LATCH system in your vehicle, you need a child restraint designed for that system.

To assist you in locating the lower anchors for this child restraint system, each seating position with the LATCH system has a label on the seatback at each lower anchor position.



The labels are located near the base of all three rear seating positions.

Caution

If a LATCH-type child restraint is not attached to its anchorage points, the restraint will not be able to protect the child correctly. In a crash, the child could be seriously injured or killed. Make sure that a LATCH-type child restraint is properly installed using the anchorage points, or use the vehicle's safety belts to secure the restraint, following the instructions that came with that restraint, and also the instructions in this manual.

Securing a Child Restraint Designed for the LATCH System

1. Find the LATCH anchorages for the seating position you want to use, where the bottom of the seatback meets the back of the seat cushion. See *Lower Anchorages and Top Tethers for Children (LATCH System)*.
2. Put the child restraint on the seat.
3. Your child seat may be equipped with either rigid or flexible attachments. Flexible attachments are usually attached to material similar to seat belt webbing. Rigid attachments are built into the base of the child restraint. If your child restraint has flexible attachments, attach and tighten the LATCH attachments on the child restraint to the LATCH anchorages in the vehicle. The child restraint instructions will show you how. If your child restraint has rigid attachments, attach them to the LATCH anchors in the vehicle per the manufacturer's instructions. In the center position, you may attach one anchor and then rotate the child restraint to attach the second anchor. If this is too difficult, you may install the child restraint at either of the rear outboard positions or use the vehicle's safety belts to attach the child restraint in the rear center position. See the following section for *Securing a Child Restraint in a Rear Seat Position* in your owner manual.
4. If the child restraint is forward-facing, attach and tighten the top strap, if equipped, to the top strap anchor. Refer to the child restraint instructions and the following steps:
 - 4.1 Find the top strap anchor.
 - 4.2 Route and tighten the top strap according to your child restraint instructions and the following instructions:

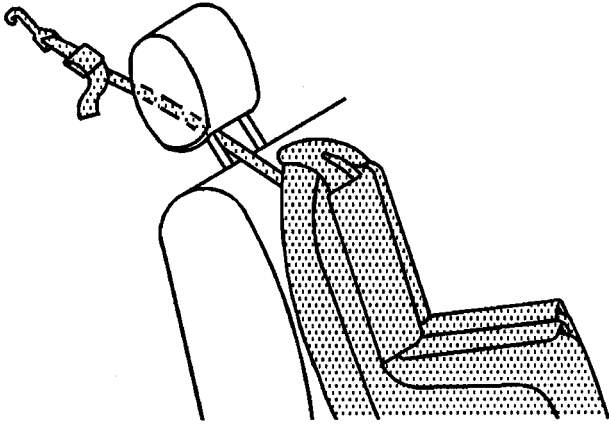

If the position you are using has a head restraint and you are using a single tether, route the tether under the head restraint and in between the head restraint posts.

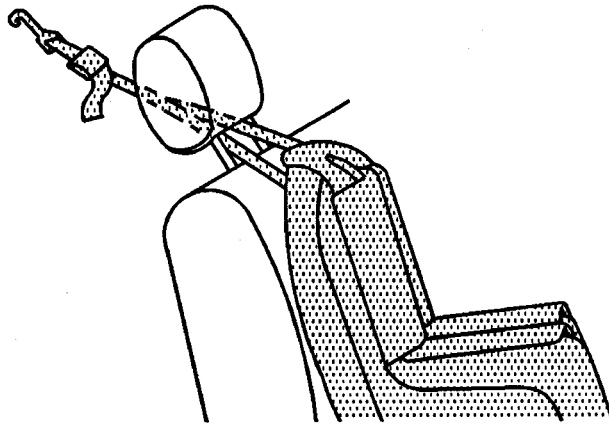

If the position you are using has a head restraint and you are using a dual tether, route the tether under the head restraint and in between the head restraint posts.

4.3 You may have to raise the head restraint to route and tighten the top strap. Be sure to lower the head restraint once the child restraint is secure.

5. Push and pull the child restraint in different directions to be sure it is secure.

To remove the child restraint, simply unhook the top strap from the top strap anchorage and then disconnect the LATCH attachments from the LATCH anchorages.

CLAIM INFORMATION

Submit a Product Recall Claim with the information indicated below:

REPAIR PERFORMED	PART COUNT	PART NO.	PARTS ALLOW	CC-FC	LABOR OP	LABOR HOURS
Update Owner Manual	N/A	N/A	N/A	MA-96	V1327	0.2

Refer to the General Motors WINS Claims Processing Manual for details on Product Recall Claim Submission.

CUSTOMER NOTIFICATION

General Motors will notify customers of this recall on their vehicle (see copy of customer letter included with this bulletin).

DEALER RECALL RESPONSIBILITY

The US National Traffic and Motor Vehicle Safety Act provides that each vehicle that is subject to a recall of this type must be adequately repaired within a reasonable time after the customer has tendered it for repair. A failure to repair within sixty days after tender of a vehicle is prima facie evidence of failure to repair within a reasonable time. If the condition is not adequately repaired within a reasonable time, the customer may be entitled to an identical or reasonably equivalent vehicle at no charge or to a refund of the purchase price less a reasonable allowance for depreciation. To avoid having to provide these burdensome remedies, every effort must be made to promptly schedule an appointment with each customer and to repair their vehicle as soon as possible. In the recall notification letters, customers are told how to contact the US National Highway Traffic Safety Administration if the recall is not completed within a reasonable time.

This bulletin is notice to you that the new motor vehicles included in this recall may not comply with the standard identified above. Under Title 49, Section 30112 of the United States Code, it is illegal for a dealer to sell a new motor vehicle which the dealer knows does not comply with an applicable Federal Motor Vehicle Safety Standard. As a consequence, if you sell any of these motor vehicles without first performing the recall correction, your dealership may be subject to a civil penalty for each such sale.

All unsold new vehicles in dealers' possession and subject to this recall must be held and inspected/repared per the service procedure of this recall bulletin before customers take possession of these vehicles.

Dealers are to service all vehicles subject to this recall at no charge to customers, regardless of mileage, age of vehicle, or ownership, from this time forward.

Customers who have recently purchased vehicles sold from your vehicle inventory, and for which there is no customer information indicated on the dealer listing, are to be contacted by the dealer. Arrangements are to be made to make the required correction according to the instructions contained in this bulletin. A copy of the customer letter is provided in this bulletin for your use in contacting customers. Recall follow-up cards should not be used for this purpose, since the customer may not as yet have received the notification letter.

In summary, whenever a vehicle subject to this recall enters your vehicle inventory, or is in your dealership for service in the future, you must take the steps necessary to be sure the recall correction has been made before selling or releasing the vehicle.

GM bulletins are intended for use by professional technicians, NOT a "do-it-yourselfer". They are written to inform these technicians of conditions that may occur on some vehicles, or to provide information that could assist in the proper service of a vehicle. Properly trained technicians have the tools, equipment, safety instructions, and know-how to do a job properly and safely. If a condition is described, **DO NOT** assume that the bulletin applies to your vehicle, or that your vehicle will have that condition. See your dealer/retailer for information on whether your vehicle may benefit from the information.



**We Support
Voluntary
Technician
Certification**

April 2005

Dear General Motors Customer:

This notice is sent to you in accordance with the requirements of the National Traffic and Motor Vehicle Safety Act.

Reason For This Recall: General Motors has decided that certain 2005 Pontiac G6 vehicles fail to conform to Federal Motor Vehicle Safety Standard 225 requirements for child restraint lower anchorage location and owner manual information for the rear center seat. Without additional owner manual information, an owner may encounter difficulty in installing child restraints with rigid attachments in the center position.

If difficulty is encountered when trying to secure a child restraint in the rear center seating position, the restraint should be moved to either outboard seating positions.

What Will Be Done: We have enclosed an owner manual update that describes the location and proper use of the anchorages in all three rear seating positions. Please review this information and then place it in your owner manual for future reference.

Contacting Your Dealer: If you have any questions, contact your dealer or the appropriate Customer Assistance Center at the listed number below. The Customer Assistance Center's hours of operation are from 8:00 AM to 11:00 PM, EST, Monday through Friday.

Division	Number	Text Telephones (TTY)
Pontiac	1-800-620-7668	1-800-833-7668
Puerto Rico – English	1-800-496-9992	
Puerto Rico – Español	1-800-496-9993	
Virgin Islands	1-800-496-9994	
Guam	1-671-648-8650	

If, after contacting your dealer or the appropriate Customer Assistance Center, you are still not satisfied that we have done our best to remedy this condition without charge and within a reasonable time, you may wish to write the Administrator, National Highway Traffic Safety Administration, 400 Seventh Street, SW, Washington, DC 20590 or call 1-888-327-4236.

Owner Center Online: This free online service offers vehicle and ownership related information and tools tailored to your specific vehicle. To get the most personalized information for your vehicle, visit www.mygmink.com, and enter your vehicle's 17-character vehicle identification number (VIN) shown on the enclosed customer reply form.

Federal regulation requires that any vehicle lessor receiving this recall notice must forward a copy of this notice to the lessee within ten days.

We are sorry to cause you this inconvenience; however, we have taken this action in the interest of your safety and continued satisfaction with our products.

General Motors Corporation

Enclosure
05005