

ISUZU

Campaign Service BULLETIN

IMPORTANT SERVICE INFORMATION FOR:

- ✓ SERVICE MANAGER
- ✓ SERVICE ADVISOR
- ✓ TECHNICIAN
- ✓ PARTS DEPARTMENT
- ✓ WARRANTY PERSONNEL

BULLETIN NUMBER:
SB05-11-S007

ISSUE DATE:
MARCH 2005

GROUP:
BODY

WINDSHIELD URETHANE ADHESION FMVSS NONCOMPLIANCE RECALL 05V-035



CAMPAIGN IDENTIFICATION NUMBER

Number 05V-035 has been assigned to this campaign by the National Highway Traffic Safety Administration (NHTSA). This number will appear on all communications and documentation of any nature dealing with the campaign.

AFFECTED VEHICLES

2005 Isuzu Ascender (UT)

Involved are **certain** 2005 model year Isuzu Ascender (UT) vehicles. Refer to the attached VIN listing and validate vehicle's VIN through Isuzu Communication System (ICS) Vehicle Inquiry or IsuzuONE.com Vehicle Inquiry.

SERVICE INFORMATION

Condition:

The manufacturer General Motors has decided that certain 2005 model year Isuzu Ascender fail to conform to Federal Motor Vehicle Safety Standard 212, Windshield Mounting. The windshield urethane bead on some of these vehicles may not have adhered to the body in certain areas during the cure process. In the event of a crash, the windshield may not be retained,

increasing the risk of personal injuries to the vehicle occupants.

Correction:

Dealers are to replace the windshield.

DEALER RESPONSIBILITY

Isuzu dealers are required to service all eligible vehicles at no charge to the owner, regardless of mileage, age of vehicle or ownership.

Whenever a vehicle subject to this campaign is in a dealer's vehicle inventory, or arrives at the dealership for service, the dealer must take the necessary steps to ensure that this campaign correction has been made before selling or releasing the vehicle.

Each Isuzu dealer will be supplied a copy of the AIMI Campaign Report (AWS-123-1A) listing affected vehicles assigned to that dealership. The report contains VIN and detailed owner information obtained from state motor vehicle registration records. The use of such motor vehicle registration data for any other purpose is a violation of the law in several states. Accordingly, dealers are urged to limit the use of this listing to the follow-up necessary to complete this campaign. If none of the affected vehicles

are assigned to a dealership, no campaign report will be sent.

OWNER NOTIFICATION

Isuzu Motors America, Inc. will send a notification letter to owners of affected vehicles already retailed (see enclosed copy). Dealers should follow up with vehicle owners by sending a Campaign Reminder Notice (AIMI SVCF-1052) to all vehicle owners listed in the AIMI Campaign Report (AWS-123-1A). Dealers may obtain these postcards from their Regional Office.

SERVICE PROCEDURE

Tools Required

- J 24404-A Glass Sealant Remover (Cold Knife)
- J 39032 Stationary Glass Removal Tool
- Urethane Adhesive Kit P/N 8-12346-392-0 or Equivalent
- Isopropyl Alcohol or Equivalent
- Cartridge-type Caulking Gun
- Commercial-type Utility Knife
- Razor Blade Scraper
- Suction Cups
- Plastic Paddle

IMPORTANT: Before cutting out a stationary window, apply a double layer of masking tape around the perimeter of the painted surfaces and the interior trim.

1. Open the hood.

CAUTION: If broken glass falls into the defroster outlets, it can be blown into the passenger compartment and cause personal injury.

2. Cover and protect the following parts from broken glass:
 - a) Upper dash pad

- b) Defroster outlets and A/C outlets
- c) Seats and carpeting

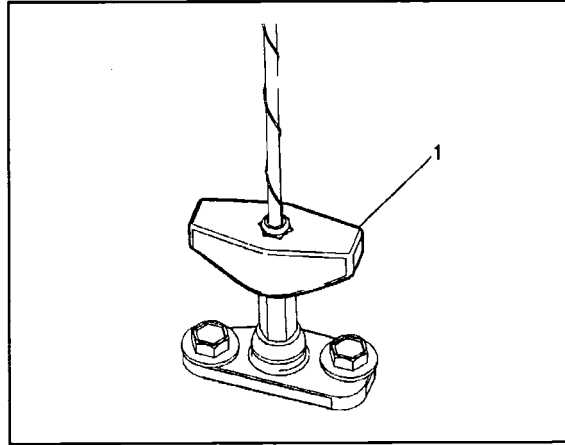

3. Use the tool (1) provided with the vehicle to unscrew the antenna mast, if equipped.

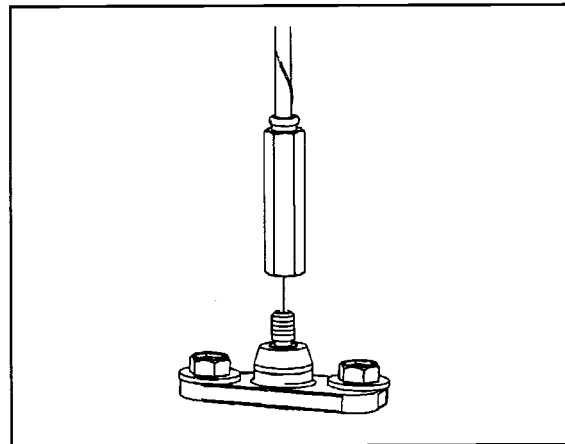

4. Remove the antenna mast from the antenna base, if equipped.
5. Remove the cover from the nut on the wiper arm.
6. Hold the wiper arm and remove the nut from the wiper arm.

IMPORTANT: Use a battery terminal puller to remove the wiper arm if rocking the wiper arm fails to loosen it from the driver shaft.

SB05-11-S007

7. Push inward at the wiper arm pivot in order to loosen it from the drive shaft.

8. Remove the wiper arm from the pivot shaft.

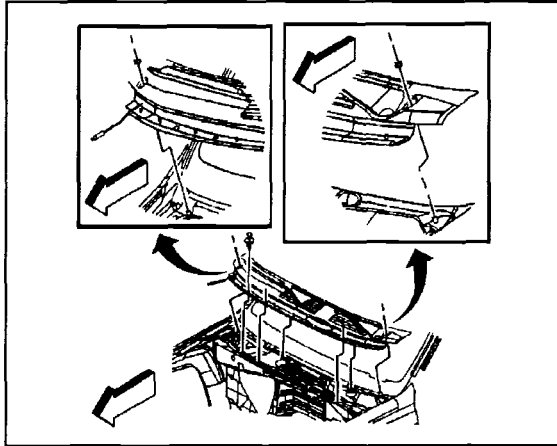

9. Remove the air inlet grille panel retaining nuts.

10. Remove the air inlet grille panel retainers.

11. Disconnect the washer hose.

12. Remove the air inlet grille panel from the vehicle by pulling upwards and to the rear in order to disengage the retaining clips.

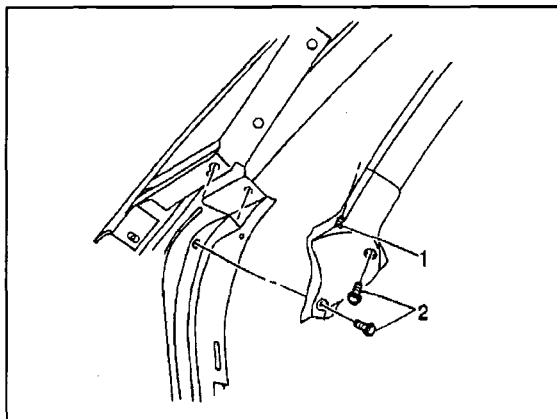

13. Remove the push-pins (2) from the front door sealing weatherstrips (1) located at the base of the pillar.

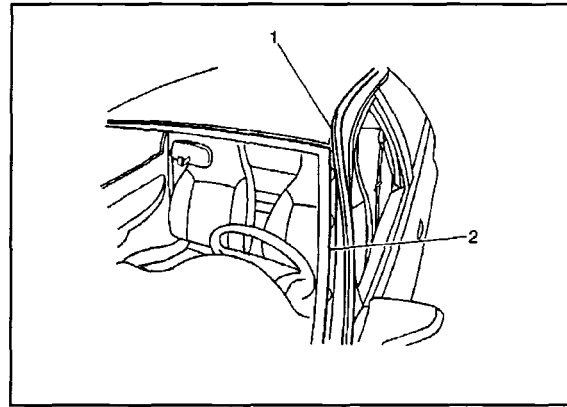

14. Reposition the front door sealing weatherstrips (1) in order to access the side reveal molding screws. It is not necessary to remove the front door sealing weatherstrip completely from the vehicle.

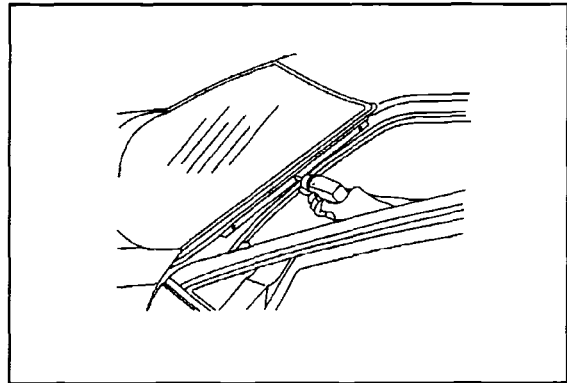

15. Remove the side reveal molding screws.

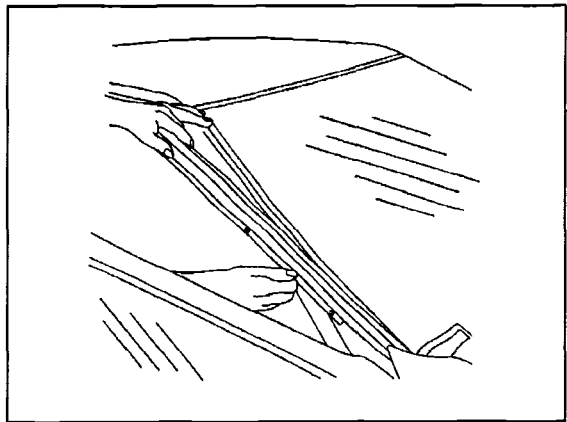

16. Remove the side of the reveal moldings.

17. Disconnect the wire cover from the upper mirror base.

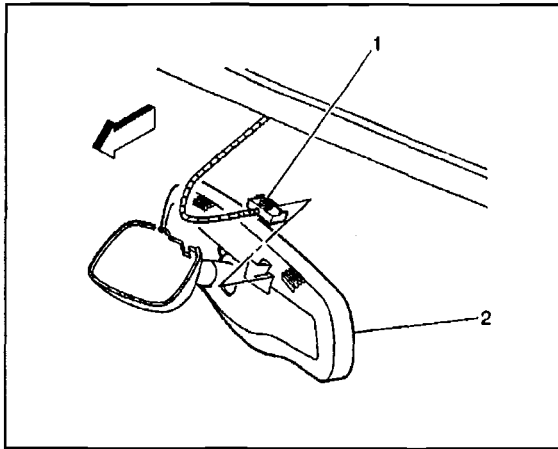

18. Use a flat-bladed tool in order to disconnect the electrical connector (1) from the mirror (2), if equipped.
19. Using a TORX® screwdriver, loosen the set screw that holds the mirror base to the windshield button.

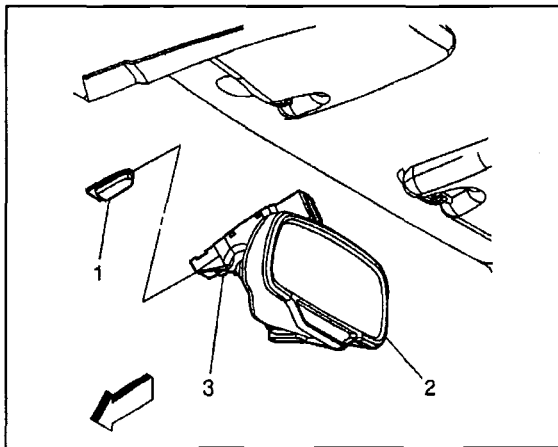

20. Slide the mirror upward off of the rear-view mirror button (1).
21. Remove the rain sensor, if equipped.

IMPORTANT: The rain sensor-retaining ring is permanently mounted to the windshield and is not serviceable. Damage to the windshield or the retaining ring will occur if removed.

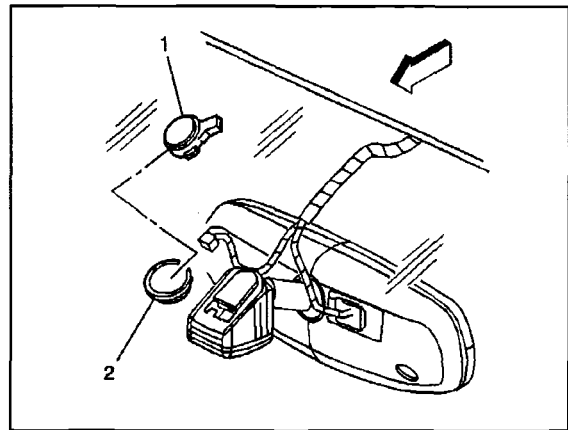

22. Disconnect the electrical connector from the rain sensor (1).
23. Carefully pull downward on the sensor (1) to release it from the retaining ring (2).

IMPORTANT: Do not touch the surface of the sensor when it is removed from the glass.

24. Remove the sensor from the vehicle.

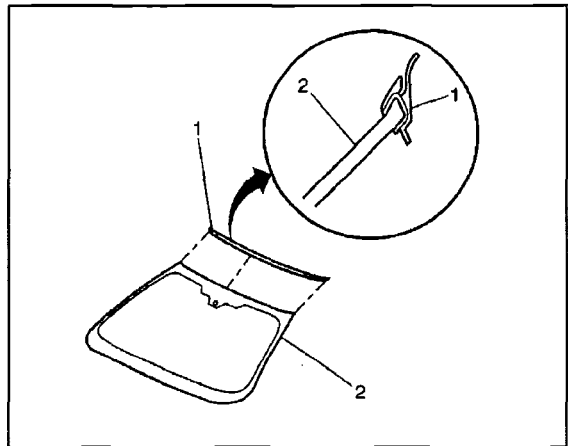

CAUTION: When working with any type of glass or sheet metal with exposed or rough edges, wear approved safety glasses and gloves in order to reduce the chance of personal injury.

IMPORTANT: The upper windshield reveal molding (1) fills the cavities between the body and windshield.

25. If the reveal molding is stretched or damaged, it cannot be reused. It must be replaced.

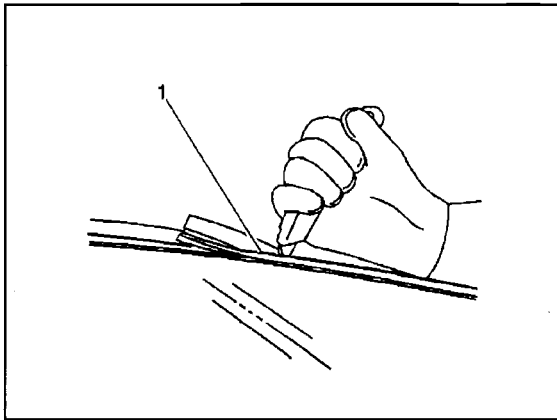

26. Remove the upper windshield reveal molding (1). Grasp the lower control of the windshield reveal molding by hand and slowly pull the reveal molding away from the windshield.

27. If the upper windshield reveal molding will not release, use a utility knife in order to cut around the windshield to remove the windshield reveal molding.

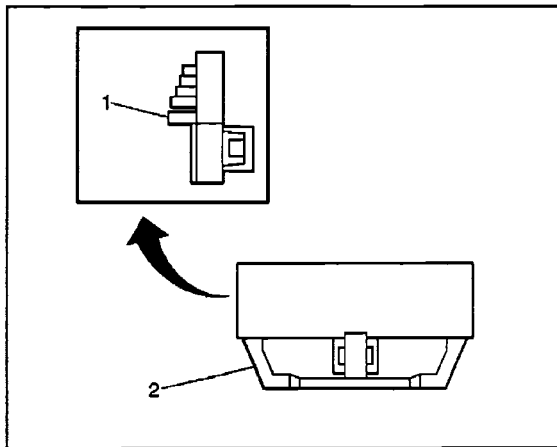

IMPORTANT: The windshield lower supports (1) have molded in locks with an adhesive strip (2) on the backside. If the windshield lower stops have been removed, they must be replaced.

28. Remove the windshield lower supports (1) by using a flat-bladed tool, lightly prying upward in the middle until it releases, if damaged.

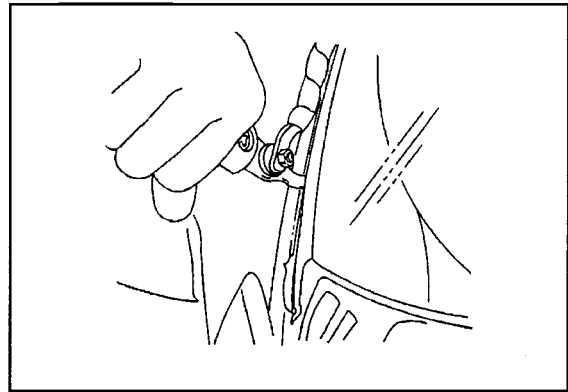

IMPORTANT: Keep the cutting edge of the tool against the window.

29. This will allow the urethane adhesive to be separated from the window.

- Leave a base of urethane on the pinch-weld flange.
- The only suitable lubrication is clear water.
- Use J 24402-A, J 39032 or equivalent in order to remove the window.

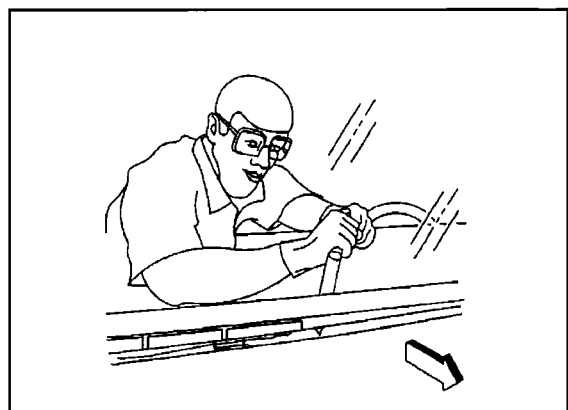

30. Remove the bottom of the windshield from the urethane adhesive using a long utility knife or similar tool. Keep the cutting edge of the utility knife against the glass. Do this from inside the vehicle.

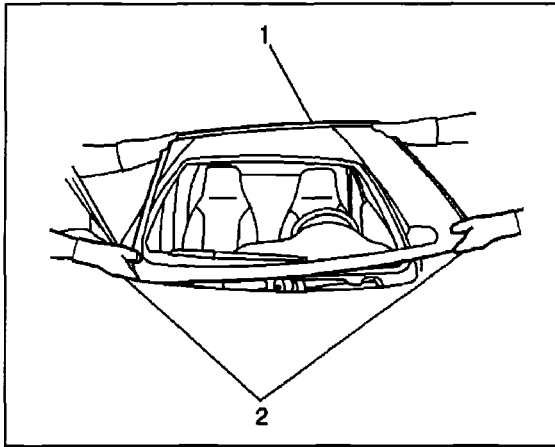

31. With the aid of an assistant, remove the windshield (1) from the vehicle.

CAUTION: When working with any type of glass or sheet metal with exposed or rough edges, wear approved safety glasses and gloves in order to reduce the chance of personal injury.

32. Remove all pieces of urethane adhesive from the pinch-weld area.
33. Inspect for any of the following problems in order to help prevent future breakage of the window.
- High weld
 - Solder spots on the pinch-weld
 - Hardened sealer
 - Any other obstruction or irregularity in the pinch-weld flange.

IMPORTANT: If corrosion of the pinch-weld flange is present or if sheet metal repairs or replacements are required, the pinch-weld flange must be refinished in order to restore the bonding area strength. If paint repairs are required, mask the flange bonding area prior to applying the color coat in order to provide a clean primer only surface. Materials such as BASF DE15®, DuPont 2610®, Sherwin-Williams PSE 4600 and NP70® and Martin-Semour 5120 and 5130® PPG DP90LF SPIES/HECKER 3688/8590 - 3688/5150 - 4070/5090 STANDOX

11158/13320 - 14653/14980 products are approved for this application.

NOTE: Please contact your ZSPM or Regional Office if any pinch-weld flange or sheet metal repairs or replacement as noted above are required.

34. After repairing the opening as indicated, perform the following steps:
- Remove all traces of broken glass from the outer cowl panel, seats, floor, and defroster ducts.
 - Clean around the edge of the inside surface of the window with a 50/50 mixture of isopropyl alcohol and water by volume on a dampened lint free cloth.

CAUTION: When replacing stationary windows, use Urethane Adhesive Kit P/N 8-12346-392-0, or a urethane adhesive system meeting the manufacturer General Motors GM Specification GM3651G, to maintain original installation integrity. Failure to use the urethane adhesive kit will result in poor retention of the window, which may allow unrestrained occupants to be ejected from the vehicle resulting in personal injury.

35. Verify all primers and urethane adhesive are within expiration dates.

CAUTION: Failure to prep the area prior to the application of primer may cause insufficient bonding of urethane adhesive. Insufficient bonding of urethane adhesive may allow unrestrained occupants to be ejected from the vehicle resulting in personal injury.

IMPORTANT: Apply the primer only to the primed surfaces.

36. Shake the pinch-weld primer black #3 for at least 1 minute.

37. Use a new dauber in order to apply the primer to the surface of the pinch-weld flange.
38. Allow the pinch-weld primer to dry for approximately 10 minutes.

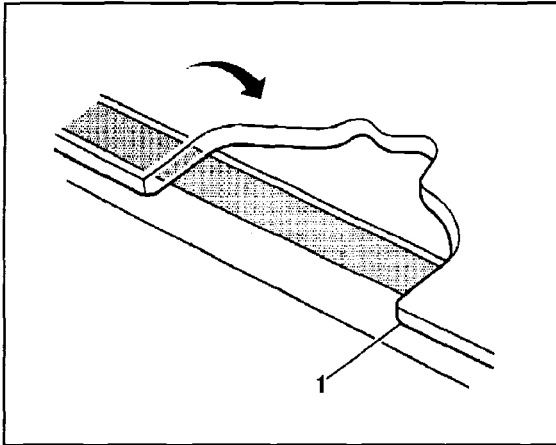

NOTICE: Do not use spacers when installing a windshield. The stress caused by the spacers may damage the windshield.

39. Install the windshield (1) and the VIN plate filler strip, if equipped.
40. Install the window to the vehicle.

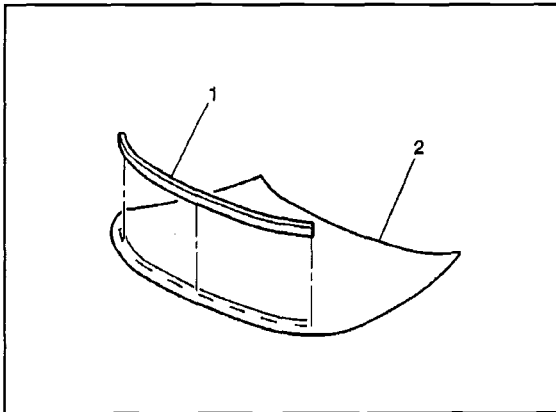

41. Install the new windshield acoustic strip (1) to the windshield (2), if equipped or damaged. The acoustic strip aids in reducing noise.

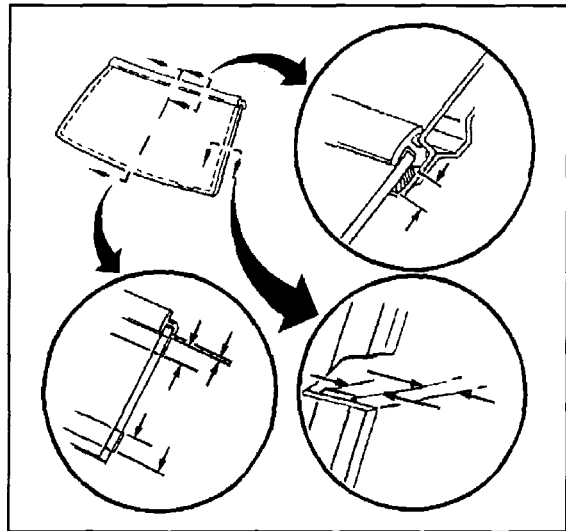

42. If installing a new window reveal molding, start in the center and work toward each end pressing firmly into place.

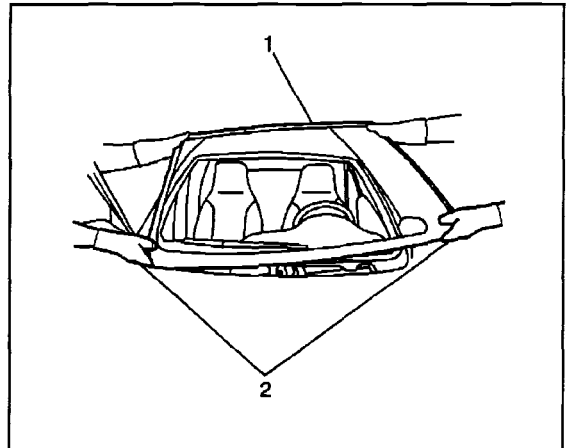

43. With the aid of an assistant, dry fit the window (1) to the opening in order to determine the correct position.

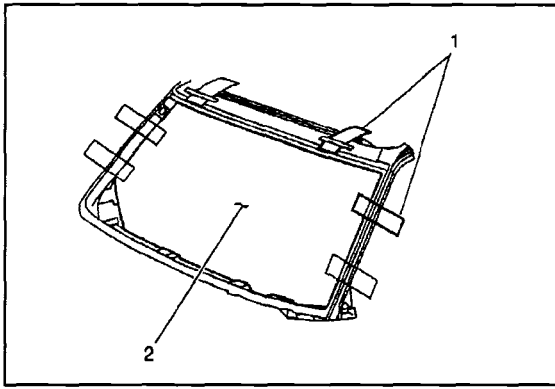

44. Use masking tape in order to mark the locations (1) of the window (2) in the opening.
45. Cut the masking tape in the center and remove the window from the opening.

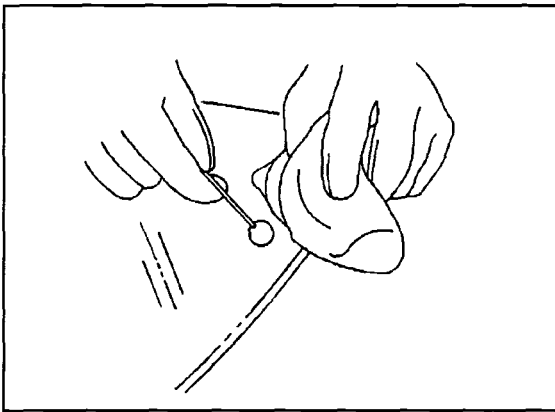

IMPORTANT: Use care when applying glass prep clear #1 on the window. This primer dries almost instantly, and may stain the viewing area of the window if not applied evenly.

46. Use a new dauber in order to apply glass prep clear #1 to the area approximately 10-16 mm (3/8-5/8 in) around the entire perimeter of the window inner surface. Immediately wipe the glass primed area using a clean, lint-free cloth.

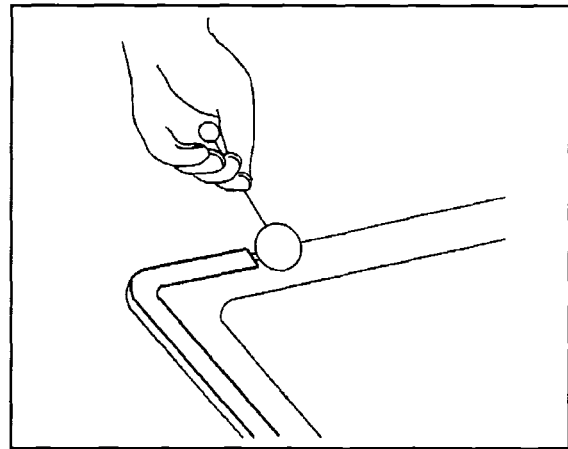

47. Apply a second coat of the glass prep clear #1 to the same area of the glass.

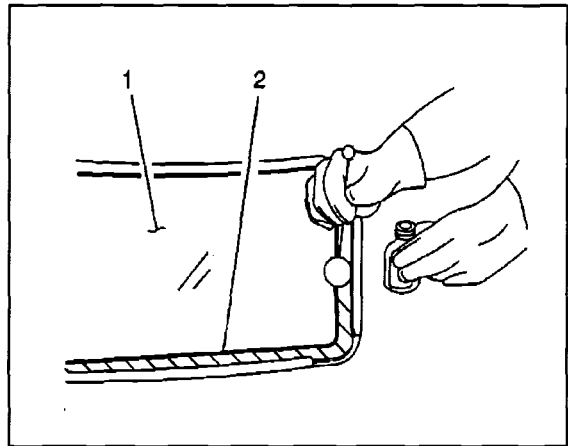

IMPORTANT: The glass primer black #2 is effective up to 8 hours after applying it to the glass. The primed surface of the glass must be kept clean.

48. Shake the glass primer black #2 for at least 1 minute.
49. Use a new dauber in order to apply the glass primer black #2 to the same areas (2) that glass prep clear #1 was applied.
50. Allow the glass primer to dry for approximately 10 minutes.

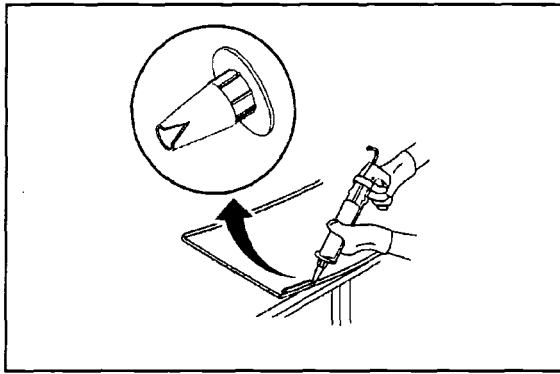

51. Cut the applicator nozzle in order to provide a bead of 12.7 mm (1/2 in) wide and 12.7 mm (1/2 in) high.

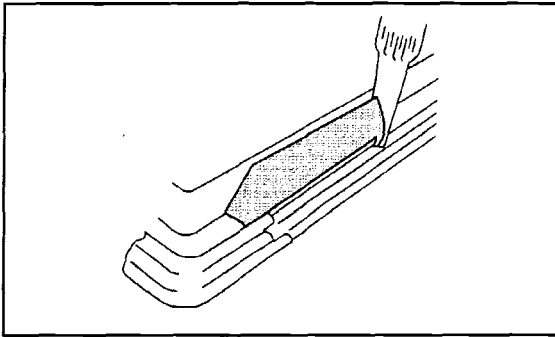

52. Use a cartridge-type caulking gun in order to apply a smooth, continuous bead of urethane adhesive.

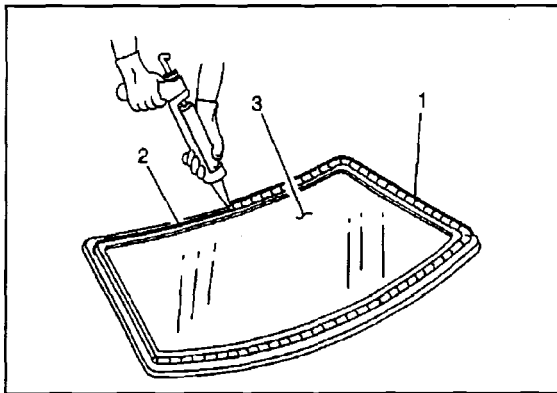

53. Use the edge of the window or the inside edge of the reveal molding as a guide for the nozzle in order to apply the urethane adhesive (1) to the inner surface of the window (3).

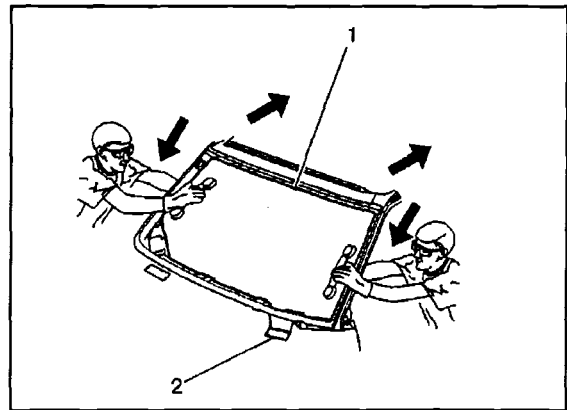

54. With the aid of an assistant, place the window in the opening. Place the windshield on the lower supports (2), if equipped.

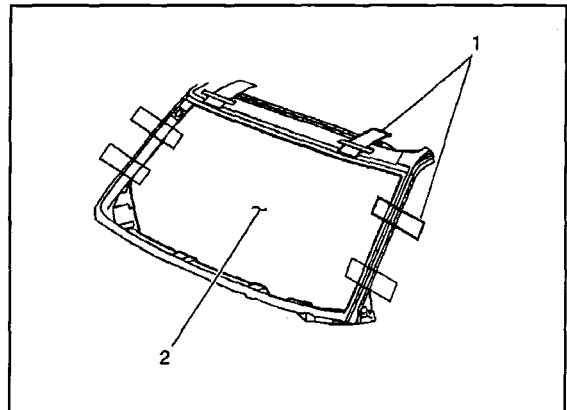

55. Align the masking tape (1) lines on the window (2) and the body.

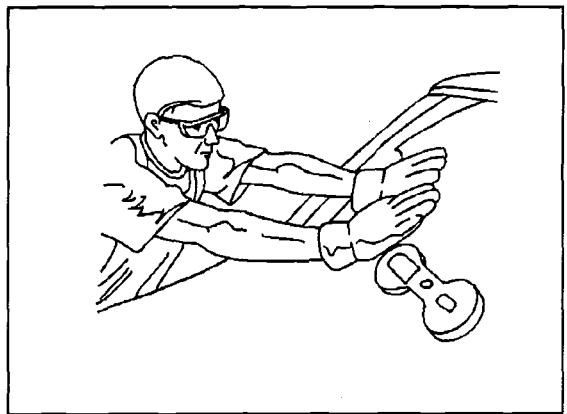

56. Press the window firmly into place.

SB05-11-S007

57. Tape the window to the body in order to minimize movement until the urethane adhesive cures.

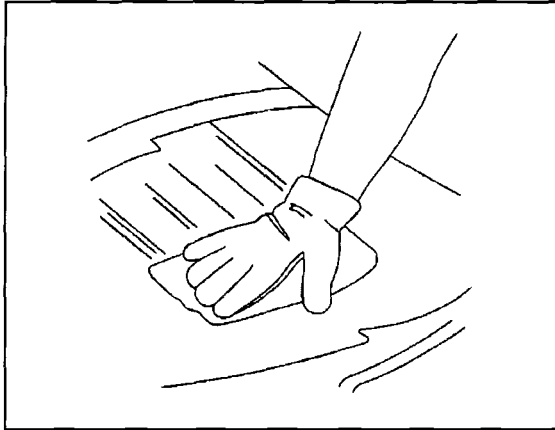

58. Clean any excess urethane adhesive from the body.

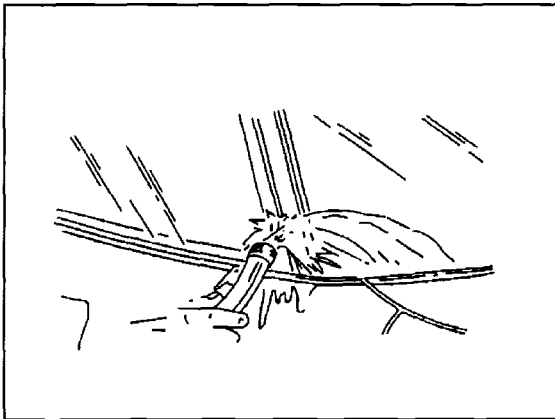

IMPORTANT: Do not direct a hard stream of high pressure water to the freshly applied urethane adhesive.

59. Use a soft spray of warm water in order to immediately water test the window.

60. Inspect the window for leaks.

61. If any leaks are found, use a plastic paddle in order to apply extra urethane adhesive at the leak point.

62. Retest the window for leaks.

CAUTION: Insufficient curing of urethane adhesive may allow unrestrained occupants to be ejected from the vehicle resulting in personal injury.

- For the moisture-curing type of urethane adhesive, allow a minimum of 6 hours at 21°C (70°F) or greater and with at least 30 percent relative humidity. Allow at least 24 hours for the complete curing of the urethane adhesive.
- For the chemical-curing type of urethane adhesive, allow a minimum of 1 hour.

Do NOT physically disturb the repair area until after these minimum times have elapsed.

63. Maintain the following conditions in order to properly cure the urethane adhesive:

- Partially lower a door window in order to prevent pressure buildups when closing doors before the urethane adhesive cures.
- Do not drive the vehicle until the urethane adhesive is cured. Refer to the above curing times.
- Do not use compressed air in order to dry the urethane adhesive.

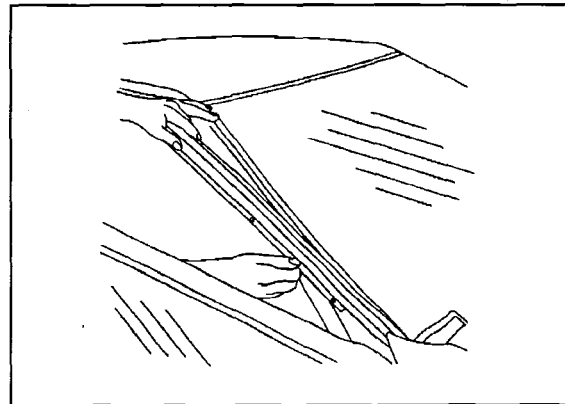

64. Install the windshield side reveal moldings.

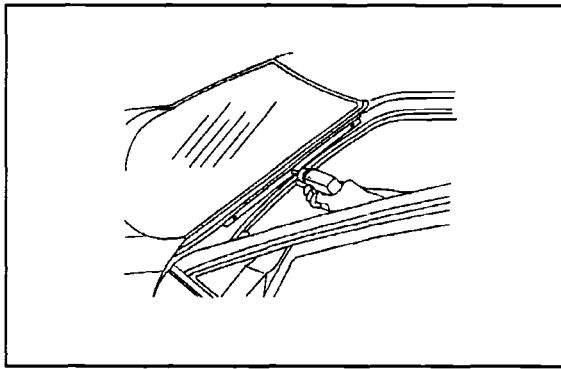

65. Install the windshield side reveal moldings screws. **Tighten**

Tighten the windshield side reveal moldings screws to 2 N·m (18 lb in).

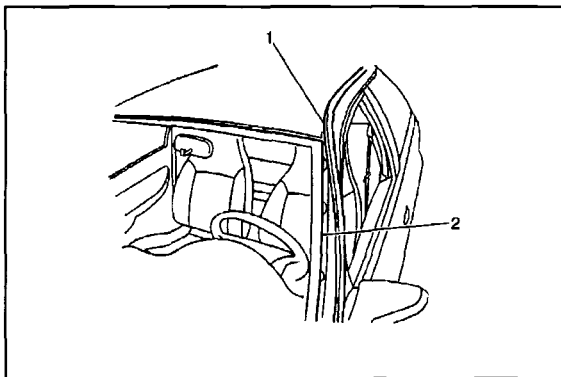

66. Reposition the front door sealing weatherstrips (1) to the pinch-weld flange.

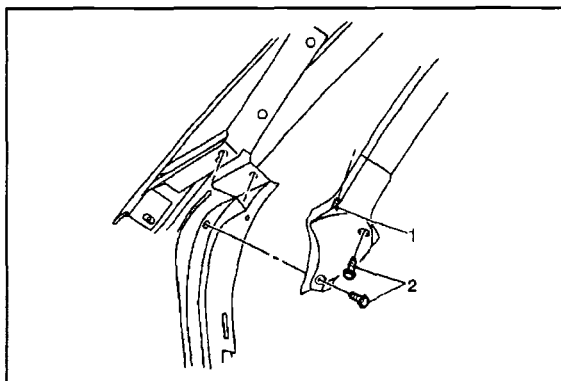

67. Install the push-pin retainers (2) to the front door sealing weatherstrips located at the base of the windshield pillar.

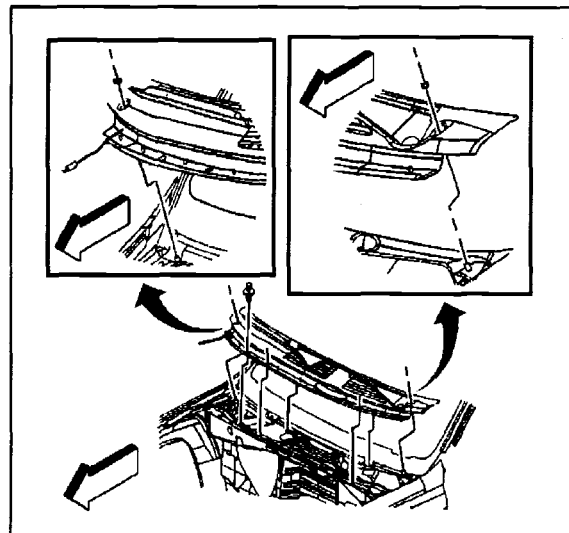

68. Position the air inlet grille panel to the rear edge of the hood.

69. Push downward on the air inlet grille panel to seat the retaining clips.

70. Connect the washer hose.

71. Install the retainers and secure.

72. Install the air inlet grille retaining nuts. **Tighten**

Tighten the air inlet grille nuts to 4 N·m (35 lb in).

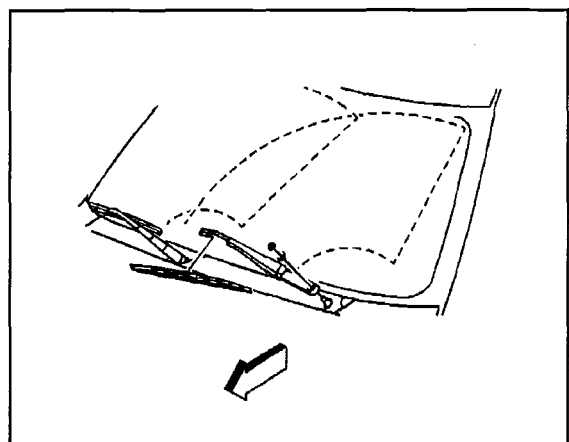

73. Install the wiper arm onto the drive shaft.

SB05-11-S007

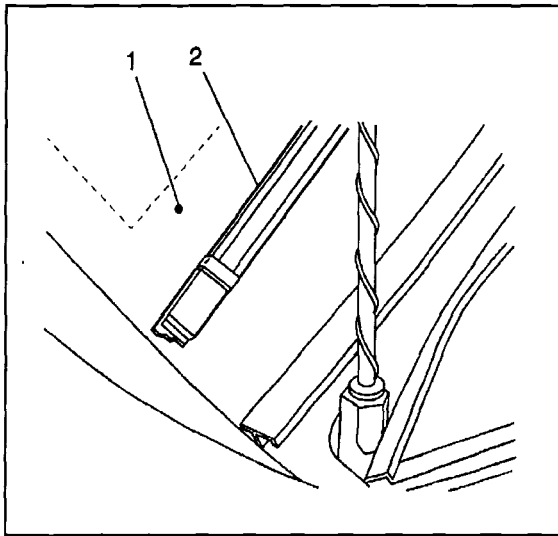

74. Hold the wiper arm blade (2) in position to the dots (1) in the windshield blackout area.

75. Install the nut on the drive shaft.
Tighten

Tighten the nut to 30 N·m (22 lb ft).

76. Install the cover on the nut.

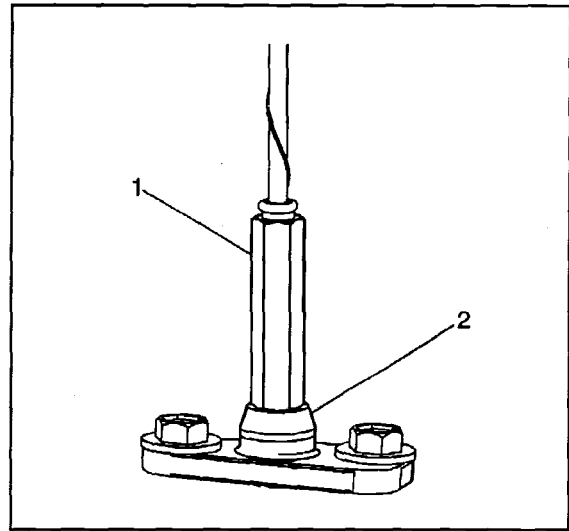

IMPORTANT: Install the antenna mast using the mast tool. Ensure the antenna mast is fully seated to the antenna base.

78. Using the mast tool, tighten the antenna mast (1) until fully seated to the antenna base (2), if equipped. Return the tool to the vehicle.

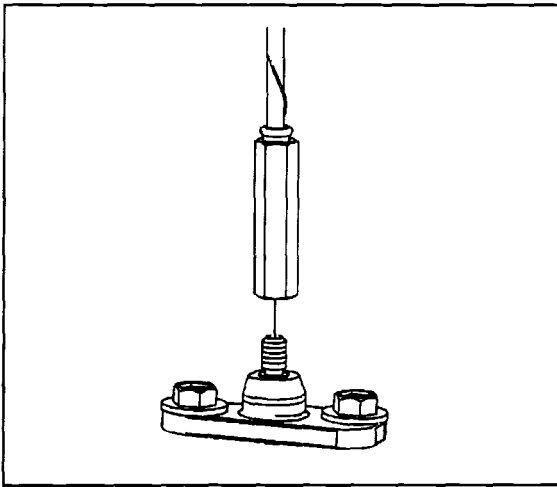

77. Install the antenna mast to the antenna base, if equipped.

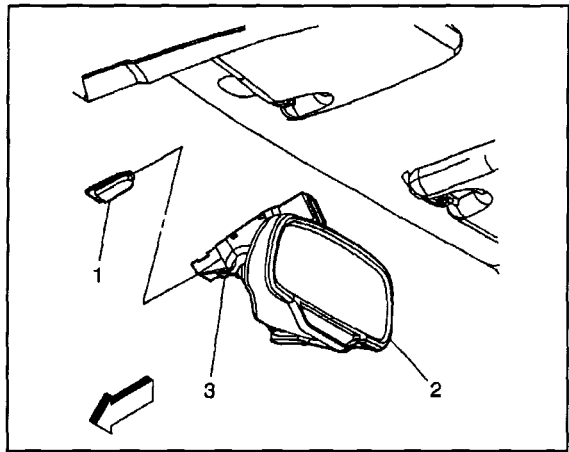

79. Slide the mirror (2) onto the support button (1).

80. Install the set screw. **Tighten**

Tighten the set screw to 2 N·m (18 lb in).

81. Connect the wire cover to the upper mirror base.

SB05-11-S007

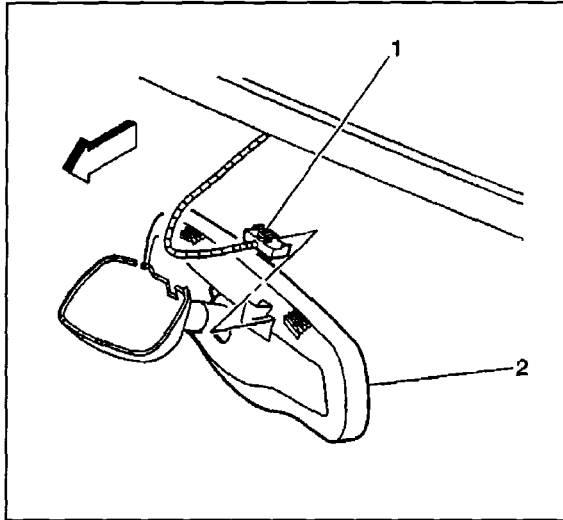

82. Connect the electrical connector (1), if equipped.

83. Reposition the mirror.

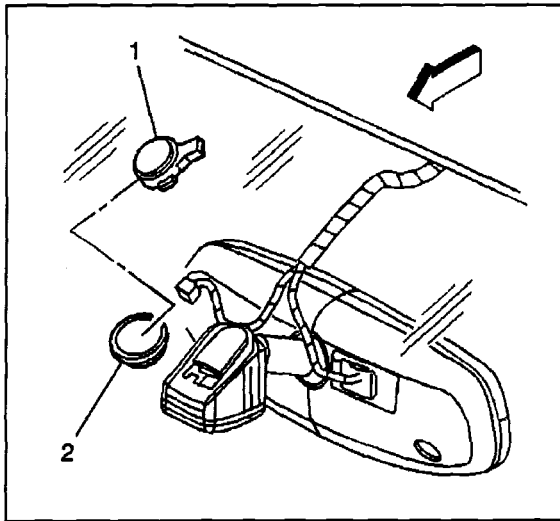

84. Clean the mounting location for the moisture sensor (2) on the windshield using a clean lint free cloth with isopropyl alcohol.

85. Install the rain sensor (1) to the windshield.

86. Connect the electrical connector to the rain sensor (1).

87. Close the hood.

88. Remove the double layer of masking tape around the perimeter of the painted surfaces and the interior trim.

COURTESY TRANSPORTATION

If needed, dealers are to provide customers affected by Campaign 05V-035 with a shuttle service or ensure that some other form of courtesy transportation is available and will be provided to the customer at no charge.

APPLYING THE CAMPAIGN LABEL

Affix the campaign label Part Number 2-90028-700-0 adjacent to the manufacturer's identification label located inside the driver's door. Using a ballpoint pen, fill in the label with campaign number 05V-035, Isuzu dealer code and repair date.

ISUZU	
CAMPAIGN NUMBER	

DEALER CODE:	_____
REPAIR DATE:	_____
P/N 2-90028-700-0	

PARTS INFORMATION

Parts required to complete this recall are to be obtained from American Isuzu Parts Distribution Network (AIPDN). Please refer to your "involved vehicles listing" before ordering parts. Normal orders should be placed on a "D" = Daily Order. In an emergency situation, parts should be ordered on a "V" = Vehicle Off Road Order.

IMPORTANT: You must use GM glass supplied by AIPDN for this repair. Dealers who sublet this repair, please inform your supplier of this information.

Part Number	Description	Quantity/Vehicle
8-10367-692-0	Windshield (w/Rainsense™)	1
8-10367-694-0	Windshield (w/o Rainsense™)	1
8-12346-392-0	Adhesive Kit, Gls Urethane (or equivalent)	1
8-15095-432-0	Molding, W/S Upr Rvl	1 (If Required)
8-15061-964-0	Support, W/S	As Required.
8-89044-634-0	Retainer Kit, WSW Blade	As Required.
8-11589-183-0	Nut	As Required.
8-21075-686-0	Retainer	As Required.
8-11609-411-0	Nut	As Required.

WARRANTY CLAIM INFORMATION

Use the following labor operation:

Operation	Operation No.	Task	Special Inst.	Time	Additional Inst.	Failed P/N	Trouble Code	Sublet Code	Sublet Allowance
Install Windshield	11V1316	Replace		1.2hr	Includes: Water test and extra technician's assistance.	8-10367-692-0 or 8-10367-694-0	07	N/A	N/A
			Courtesy Transportation • Shuttle Service • Rental Car					S1 R1	\$5.00 Each Way \$35.00 per day, Maximum 2 Days W/O Prior Authorization
Install Windshield	11V1317	Sublet Repair Shop		0.0hr		8-10367-692-0 or 8-10367-694-0	07	WR	
			Courtesy Transportation • Shuttle Service • Rental Car					S1 R1	\$5.00 Each Way \$35.00 per day, Maximum 2 Days W/O Prior Authorization
			Dealer provisions for movement of vehicle to and from sublet location					*T1	*\$40.00

****Sublet Code T1 and dollar allowance is to provide transportation and administration of sublet repair. This code applies only to this Campaign (05V-035).***

NOTE:

1. Labor Time **includes** administrative time allowance.
2. Information released on paper and electronic format prior to bulletin release cannot be updated. For the most current and up to date information refer to **IsuzuONE.com**
3. Always refer to the Isuzu Service Policy Procedure Manual for specific details on warranty coverage and policies.

NATIONAL SERVICE DEPARTMENT

SB05-11-S007

X52700655	X52700980	X52700684	052700549	052700826	052701245
X52700901	X52701028	X52700698	052700552	052700838	052701247
X52701107	X52701059	X52700703	052700566	052700841	052701250
X52700493	X52701062	X52700748	052700583	052700857	052701698
X52700509	X52701076	X52700779	052700597	052700860	052701703
X52700512	X52701112	X52700829	052700602	052700869	052701715
X52700526	X52701143	X52700877	052700616	052700886	052701717
X52700543	X52701157	X52700880	052700628	052700888	052701720
X52700557	X52701160	X52700894	052700631	052700941	052701734
X52700560	X52701174	X52700913	052700633	052700967	052701746
X52700574	X52701188	X52700927	052700650	052700970	052701763
X52700588	X52701191	X52700958	052700662	052700972	052701779
X52700591	X52701210	X52700961	052700664	052701004	052701782
X52700607	X52701224	X52700975	052700681	052701018	052701794
X52700610	X52701238	X52700989	052700693	052701021	052701796
X52700638	X52701241	X52701012	052700695	052701054	052701801
X52700641	X52701255	X52701043	052700700	052701066	052701827
X52700669	X52701692	X52701172	052700712	052701068	052701846
X52700686	X52701739	X52701219	052700714	052701085	052701861
X52700705	X52701756	X52701222	052700726	052701104	052701877
X52700722	X52701773	X52701690	052700728	052701121	052701892
X52700767	X52701790	X52701740	052700745	052701135	052701894
X52700798	X52701840	X52701785	052700760	052701149	052701961
X52700848	X52701868	X52701902	052700774	052701166	152700494
X52700851	X52701899	052700497	052700793	052701183	152700508
X52700879	X52701918	052700499	052700807	052701197	152700513
X52700882	X52701935	052700504	052700809	052701200	152700530
X52700896	X52701952	052700521	052700810	052701216	152700539
X52700932	X52702048	052700535	052700812	052701233	152700544

152700558	152700895	152701709	252700648	252701010	252701802
152700561	152700897	152701710	252700665	252701019	252701833
152700575	152700900	152701757	252700680	252701024	252701876
152700589	152700916	152701774	252700682	252701055	252701928
152700592	152700931	152701788	252700694	252701069	252701931
152700608	152700945	152701810	252700715	252701072	252701960
152700611	152700950	152701824	252700727	252701086	252702139
152700625	152700981	152701836	252700729	252701105	352700500
152700642	152700993	152701855	252700758	252701117	352700514
152700654	152701001	152701869	252700792	252701119	352700528
152700656	152701027	152701870	252700811	252701122	352700531
152700671	152701029	152701872	252700825	252701151	352700559
152700723	152701032	152701905	252700827	252701184	352700562
152700737	152701044	152701922	252700830	252701198	352700576
152700740	152701058	152701936	252700839	252701201	352700609
152700752	152701061	152702150	252700844	252701203	352700624
152700754	152701077	252700486	252700856	252701215	352700626
152700783	152701080	252700505	252700858	252701217	352700657
152700785	152701125	252700519	252700873	252701220	352700660
152700797	152701130	252700536	252700889	252701234	352700672
152700799	152701156	252700548	252700890	252701251	352700691
152700816	152701161	252700553	252700892	252701697	352700719
152700818	152701175	252700567	252700906	252701704	352700736
152700833	152701187	252700570	252700937	252701721	352700738
152700835	152701189	252700584	252700954	252701733	352700741
152700849	152701190	252700598	252700973	252701735	352700753
152700864	152701206	252700601	252700990	252701749	352700769
152700866	152701223	252700603	252700999	252701766	352700770
152700881	152701242	252700634	252701005	252701797	352700772

352700784	352701131	352702022	452700862	452701202	552700563
352700803	352701159	452700487	452700874	452701204	552700577
352700817	352701162	452700490	452700907	452701218	552700580
352700819	352701176	452700506	452700910	452701221	552700594
352700820	352701207	452700518	452700924	452701249	552700613
352700834	352701209	452700537	452700926	452701252	552700627
352700865	352701212	452700585	452700938	452701705	552700630
352700870	352701226	452700604	452700943	452701719	552700639
352700898	352701243	452700618	452700955	452701722	552700644
352700903	352701689	452700621	452700969	452701736	552700658
352700915	352701694	452700635	452700986	452701767	552700675
352700920	352701708	452700647	452701006	452701784	552700690
352700929	352701711	452700649	452701011	452701815	552700706
352700946	352701725	452700652	452701025	452701820	552700725
352700977	352701727	452700666	452701037	452701832	552700739
352700979	352701730	452700678	452701040	452701851	552700742
352700982	352701742	452700683	452701042	452701865	552700771
352700994	352701744	452700697	452701071	452701896	552700773
352701000	352701758	452700702	452701087	452701901	552700790
352701014	352701761	452700731	452701099	452701913	552700804
352701031	352701775	452700733	452701106	452701915	552700806
352701050	352701789	452700759	452701118	452701932	552700821
352701064	352701792	452700762	452701137	452701946	552700852
352701078	352701806	452700764	452701152	552700496	552700854
352701093	352701808	452700776	452701154	552700515	552700883
352701109	352701825	452700778	452701168	552700527	552700933
352701114	352701837	452700781	452701171	552700529	552700947
352701126	352701871	452700843	452701185	552700532	552700952
352701128	352701890	452700859	452701199	552700546	552700966

552700978	552701695	652700572	652700813	652701136	652701883
552700983	552701712	652700586	652700815	652701138	652701897
552700995	552701714	652700605	652700832	652701141	652701947
552701015	552701728	652700617	652700846	652701153	652701950
552701017	552701731	652700619	652700861	652701155	752700495
552701020	552701743	652700620	652700863	652701167	752700502
552701046	552701759	652700622	652700875	652701169	752700516
552701063	552701776	652700636	652700908	652701170	752700533
552701065	552701791	652700651	652700911	652701186	752700547
552701079	552701793	652700653	652700925	652701205	752700550
552701082	552701812	652700667	652700930	652701236	752700564
552701094	552701826	652700670	652700939	652701248	752700578
552701096	552701841	652700679	652700942	652701253	752700581
552701113	552701886	652700696	652700944	652701687	752700593
552701115	552701888	652700701	652700956	652701706	752700595
552701129	552701891	652700717	652700987	652701723	752700600
552701144	552701910	652700720	652700992	652701737	752700612
552701158	552701924	652700732	652701007	652701752	752700614
552701177	552701953	652700734	652701009	652701754	752700643
552701180	652700488	652700746	652701026	652701768	752700645
552701192	652700491	652700751	652701038	652701771	752700659
552701194	652700507	652700763	652701041	652701783	752700674
552701208	652700510	652700765	652701057	652701799	752700676
552701211	652700522	652700777	652701060	652701816	752700688
552701213	652700524	652700780	652701074	652701818	752700707
552701225	652700538	652700782	652701088	652701821	752700709
552701230	652700541	652700794	652701091	652701835	752700710
552701239	652700555	652700796	652701110	652701849	752700724
552701256	652700569	652700801	652701124	652701852	752700743

752700755	752701052	752701889	852700747	852701073	852701917
752700757	752701081	752701925	852700749	852701075	952700498
752700786	752701083	752701942	852700750	852701089	952700501
752700788	752701095	852700489	852700766	852701090	952700503
752700791	752701097	852700492	852700795	852701092	952700517
752700805	752701100	852700511	852700800	852701108	952700520
752700822	752701102	852700523	852700802	852701111	952700534
752700824	752701116	852700525	852700814	852701139	952700551
752700836	752701133	852700540	852700828	852701140	952700565
752700853	752701145	852700542	852700831	852701142	952700579
752700855	752701147	852700554	852700847	852701173	952700582
752700867	752701150	852700556	852700850	852701235	952700596
752700872	752701164	852700571	852700878	852701237	952700615
752700905	752701178	852700573	852700893	852701240	952700629
752700917	752701181	852700587	852700909	852701254	952700632
752700919	752701193	852700590	852700914	852701688	952700646
752700934	752701195	852700599	852700928	852701691	952700661
752700936	752701214	852700606	852700957	852701707	952700663
752700948	752701228	852700623	852700959	852701724	952700677
752700951	752701231	852700637	852700960	852701753	952700689
752700965	752701696	852700640	852700974	852701755	952700692
752700984	752701701	852700668	852700976	852701769	952700708
752700996	752701713	852700685	852700988	852701786	952700711
752700998	752701732	852700699	852700991	852701803	952700713
752701002	752701777	852700704	852701008	852701817	952700730
752701016	752701780	852700716	852701013	852701819	952700744
752701033	752701813	852700718	852701030	852701822	952700761
752701035	752701844	852700721	852701039	852701834	952700787
752701047	752701856	852700735	852701056	852701884	952700789

952700808	952701101	952701893
952700823	952701103	952701909
952700837	952701120	
952700840	952701132	
952700842	952701134	
952700868	952701146	
952700871	952701148	
952700885	952701163	
952700887	952701179	
952700899	952701182	
952700904	952701196	
952700935	952701229	
952700940	952701232	
952700949	952701244	
952700968	952701700	
952700971	952701702	
952700985	952701716	
952700997	952701745	
952701003	952701747	
952701022	952701750	
952701034	952701764	
952701036	952701778	
952701048	952701781	
952701051	952701795	
952701053	952701800	
952701067	952701809	
952701070	952701814	
952701084	952701828	
952701098	952701831	

March 10, 2005
Campaign No.: 05V-035

Dear Isuzu Ascender Owner:

This notice is sent to you in accordance with the requirements of the National Traffic and Motor Vehicle Safety Act.

WHAT IS THE CONDITION?

General Motors has decided that certain 2005 Isuzu Ascender vehicles fail to conform to Federal Motor Vehicle Safety Standard 212, Windshield Mounting. The windshield urethane bead on some of these vehicles may not have adhered to the body in certain areas during the cure process. In the event of a crash, the windshield may not be retained, increasing the risk of personal injuries to the vehicle occupants.

WHAT WE WILL DO

To correct this condition, your Isuzu dealer will replace the windshield. This service will be performed for you at **no charge**.

HOW LONG WILL THE REPAIR TAKE?

This service correction will take approximately 7-1/2 hours. However, due to service scheduling requirements, your dealer may need your vehicle for a longer period of time.

WHAT YOU SHOULD DO

To limit any possible inconvenience, we recommend that you contact your Isuzu dealer as soon as possible to schedule an appointment for this repair. By scheduling an appointment, your dealer can ensure that the necessary parts will be available on your scheduled appointment date. Should your dealer be unable to schedule a service date within a reasonable time, you should contact the National Owner Relations Department between the hours of 6:00 AM and 5:00 PM, PST, Monday through Friday. They can be reached at (800)255-6727. In addition, to locate the nearest Isuzu dealer you can visit our website at www.isuzu.com, click on the dealer locator icon and enter your zip code or state.

If after contacting your Isuzu dealer or the National Office with any problems, you still are not satisfied that we have done our best to remedy this condition without charge and within a reasonable time, you may wish to write the Administrator, National Highway Traffic Safety Administration, 400 Seventh Street S.W., Washington, D.C. 20590 or call 1-888-327-4236.

Your dealer will assist you in making the necessary transportation arrangements while your vehicle is at the dealership for this repair. Please contact your dealer for details on courtesy transportation.

We are sorry to cause you this inconvenience; however, we have taken this action in the interest of your safety and continued satisfaction with our products.

Sincerely,
ISUZU MOTORS AMERICA, INC.

IMPORTANT: *If you have sold or traded your Isuzu vehicle, please enter the owner's name and address, if known, on the attached "Change of Information" postcard, tear off at both perforations, and drop it in the mail. Postage has already been paid. We will contact the new owner.*

Federal law requires that any vehicle lessor receiving this recall notice must forward a copy of this notice to the lessee within ten days. Lessor means a person or entity that is the owner, as reflected on the vehicle title, of any five or more leased vehicles.

SB05-11-S007