

**GM SERVICE AND PARTS OPERATIONS
DCS1404
URGENT - DISTRIBUTE IMMEDIATELY**

DATE: May 13, 2005

SUBJECT: 05004 / Product Safety Recall
Inadvertent Driver Airbag Deploy
When Ignition Key Turned To On Position

MODELS: 2004 Cadillac CTS, CTS-V, SRX

TO: All Cadillac Dealers

ATTENTION: Service Manager, Parts Manager and
Warranty Administrator

PRODUCT FIELD ACTION ANNOUNCEMENT

General Motors is announcing Product Safety Recall 05004 today. The total number of vehicles involved is 92,627. Please see the attached bulletin for details.

Mailing Information

Customer notification letter mailing will begin on May 20, 2005.

GM Vehicle Inquiry System (GMVIS)

GMVIS information will be available on May 14, 2005.

Service Information System (SI)

Bulletin 05004 is currently available in SI.

Campaign Initiation Detail Report (CIDR)

The CIDR will be available in GM DealerWorld on May 13, 2005.

PLEASE DOUBLE CLICK ON THE ICON BELOW
THEN SINGLE CLICK ON THE LAUNCH BUTTON
TO VIEW OR PRINT THE BULLETIN

(See attached file: 05004 bulletin.pdf)

END OF MESSAGE
GM SERVICE AND PARTS OPERATIONS



File In Section: Product Recalls

Bulletin No.: 05004

Date: April 2005

Recall Bulletin



PRODUCT SAFETY RECALL

SUBJECT: INADVERTENT DRIVER AIRBAG DEPLOY WHEN IGNITION KEY TURNED TO ON POSITION

MODELS: 2004 CADILLAC CTS, CTS-V, SRX

DUE TO PART AVAILABILITY, THIS BULLETIN IS BEING RELEASED IN TWO PHASES. THE FIRST PHASE WILL INCLUDE ALL CANADIAN VEHICLES. THE SECOND PHASE WILL INCLUDE ALL U.S. AND EXPORT VEHICLES.

CONDITION

General Motors has decided that a defect, which relates to motor vehicle safety, exists in **certain** 2004 model year Cadillac CTS, CTS-V, and SRX vehicles. An interaction between the sensing and diagnostic module (SDM) and the vehicle's electrical system in these vehicles may cause the driver's frontal airbag and/or roof-mounted side impact airbag to deploy when the ignition key is turned to the ON position. A person positioned for driving may receive minor injuries such as abrasions from contact with a deploying airbag.

CORRECTION

Dealers are to replace the SDM.

VEHICLES INVOLVED

Involved are **certain** 2004 model year Cadillac CTS, CTS-V, and SRX vehicles built within these VIN breakpoints:

| YEAR | DIVISION | MODEL | FROM | THROUGH |
|------|----------|-------|----------|----------|
| 2004 | Cadillac | CTS | 40100001 | 40192626 |
| 2004 | Cadillac | CTS-V | 40120823 | 40192556 |
| 2004 | Cadillac | SRX | 40100026 | 40192629 |

IMPORTANT: Dealers should confirm vehicle eligibility through **GMVIS** (GM Vehicle Inquiry System) prior to beginning recall repairs. [Not all vehicles within the above breakpoints may be involved.]

For US and Canada: For dealers with involved vehicles, a Campaign Initiation Detail Report containing the complete Vehicle Identification Number, customer name and address data has been prepared and will be loaded to the GM DealerWorld (US) Recall Information, GMinfoNet

(Canada) Recall Reports. Dealers will not have a report available if they have no involved vehicles currently assigned.

For Export: For dealers with involved vehicles, a Campaign Initiation Detail Report containing the complete Vehicle Identification Number, customer name and address data has been prepared, and is being furnished to involved dealers. Dealers that have no involved vehicles currently assigned will not receive a report with the recall bulletin.

The Campaign Initiation Detail Report may contain customer names and addresses obtained from Motor Vehicle Registration Records. The use of such motor vehicle registration data for any purpose other than follow-up necessary to complete this recall is a violation of law in several states/provinces/countries. Accordingly, you are urged to limit the use of this report to the follow-up necessary to complete this recall.

PARTS INFORMATION

Parts required to complete this recall are to be obtained from General Motors Service Parts Operations (GMSPO). Please refer to your "involved vehicles listing" before ordering parts. Normal orders should be placed on a DRO = Daily Replenishment Order. In an emergency situation, parts should be ordered on a CSO = Customer Special Order.

| Part Number | Description | Quantity/Vehicle |
|-------------|-----------------------------------|------------------|
| 19115245 | Module, Infl Rst Sen & Diag (CTS) | 1 |
| 15247500 | Module, Infl Rst Sen & Diag (SRX) | 1 |

SERVICE PROCEDURE

CTS

Removal

1. Turn the steering wheel so that the vehicle's wheels are pointing straight ahead.
2. Turn the ignition switch to the OFF position.
3. Remove the key from the ignition switch.

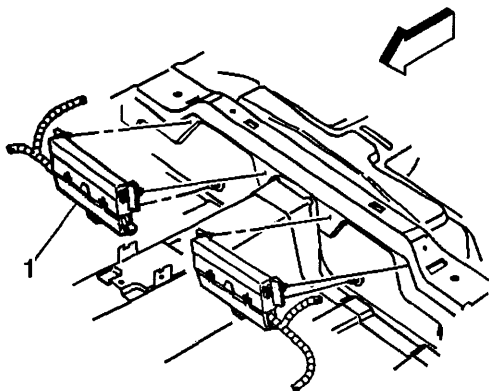

816858

4. Push in and pull up on the front of the rear seat cushion.
5. Lift up and out on the seat cushion.
6. Remove the rear seat cushion from the vehicle.

7. Locate the right rear fuse center (1) under the rear seat, and then remove the fuse center top cover.

Important: With the SIR fuse removed and the ignition switch in the ON position, the AIR BAG warning indicator illuminates. This is normal operation and does not indicate an SIR system malfunction.

8. Locate and remove the SIR fuse from the right rear fuse center.

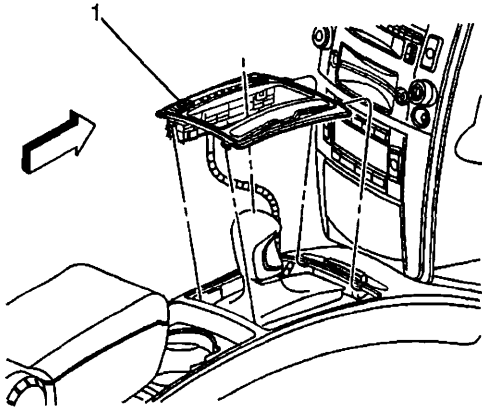

706055

9. Remove the shifter trim cover (1).

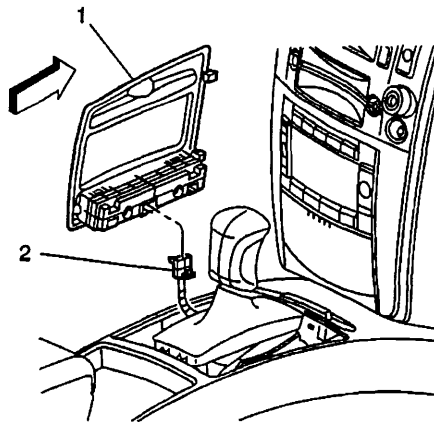

706048

10. Disconnect the electrical connector (2) from the shifter trim cover (1).

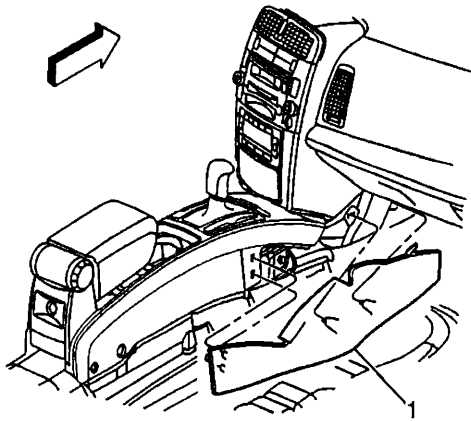

706058

11. Remove the console side trim panels (1) from the console.

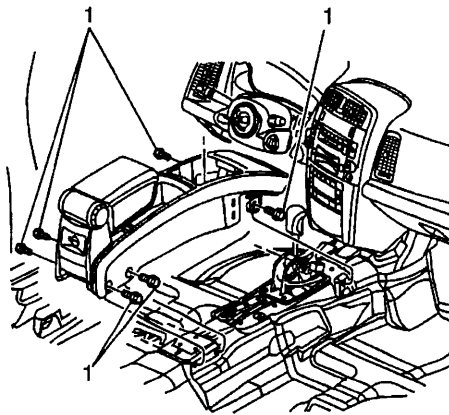

706062

12. Remove the 6 screws (1) securing the console to the floor.
13. Remove the console from the vehicle.

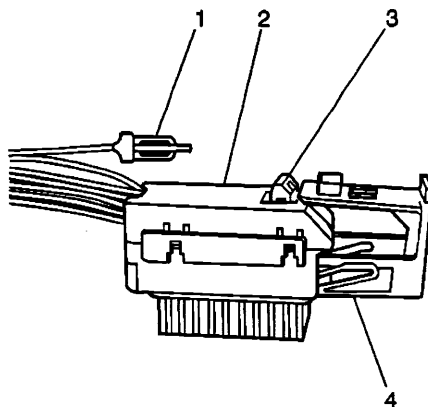

466123

14. Remove the connector position assurance (CPA) (1) from the wiring harness connector (2) to the inflatable restraint sensing and diagnostic module (SDM).
15. Push the flex lock button (3) down and move the sliding connector locking cover (4) to the OPEN position.

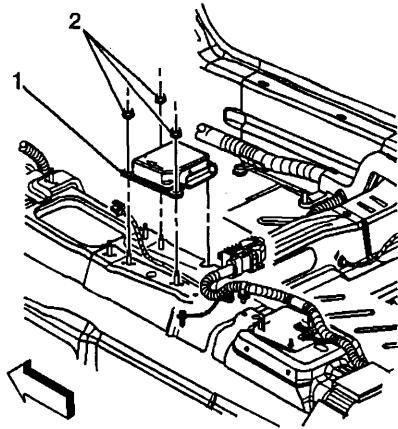

751942

Important: The SDM is shown with the carpet removed for illustration purposes only. Removal of the front carpet or the front seats is not necessary to service the SDM.

16. Disconnect the wiring harness connector from the SDM (1).
17. Remove the SDM mounting fasteners (2).
18. Remove the SDM from the console floor.

Installation

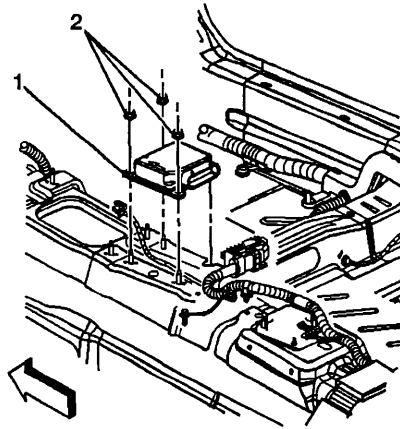

751942

1. Remove any dirt, grease, or other impurities from the mounting surface.
2. Install the SDM (1) horizontally to the console floor.
3. Point the arrow on the SDM toward the front of the vehicle.
4. Install the SDM mounting fasteners (2).

Tighten

Tighten the fasteners to 9 N·m (80 lb in).

5. Connect the wiring harness connector (1) to the SDM.

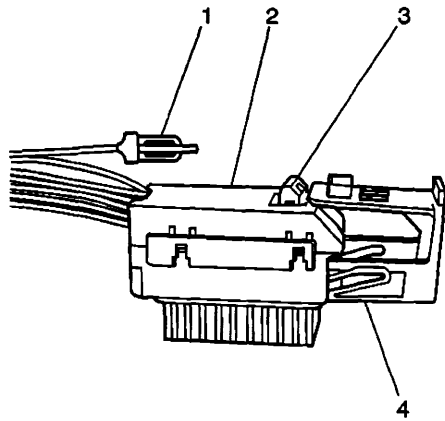

466123

6. Push the flex lock button (3) down and move the sliding connector locking cover (4) to the CLOSE position.
7. Install the CPA (1) to the wiring harness connector (2) to the inflatable restraint SDM.

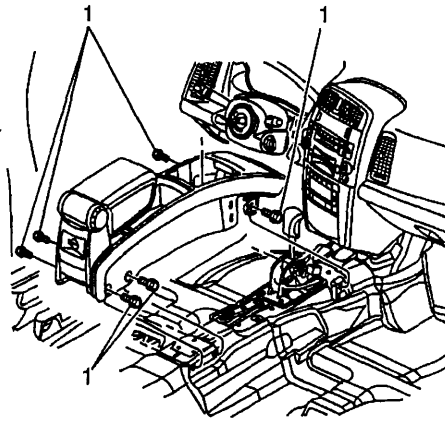

706062

8. Position the console on the floor of the vehicle.
9. Install the screws (1) securing the console to the floor.

Tighten

Tighten the fasteners to 25 N·m (18 lb ft).

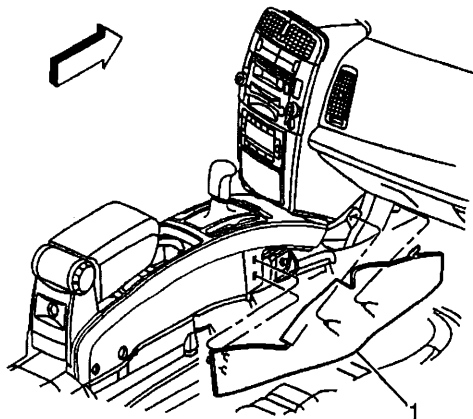

706058

10. Install the console side trim panels (1) to the console.

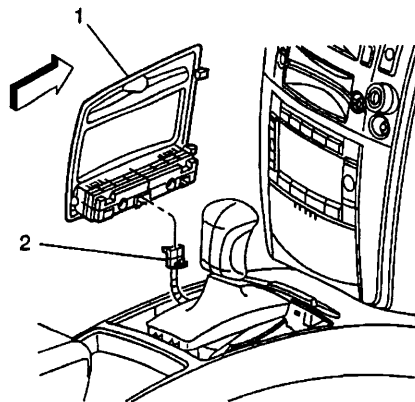

706048

11. Install the shift indicator lamp electrical connector (2).

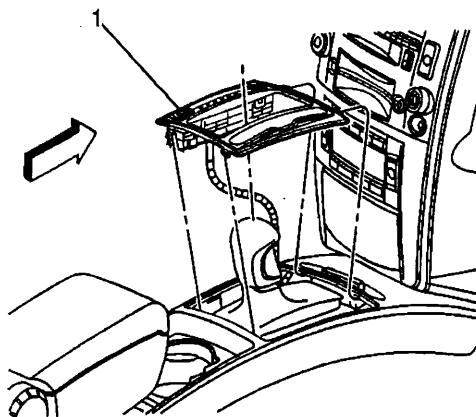

706055

12. Install the shifter trim cover (1).

13. Install the driver and the passenger seats to the original position.

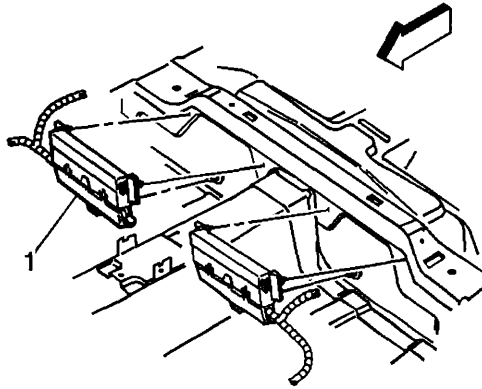

816858

14. Install the SIR fuse into the right rear fuse center (1).
15. Install the right rear fuse center cover.

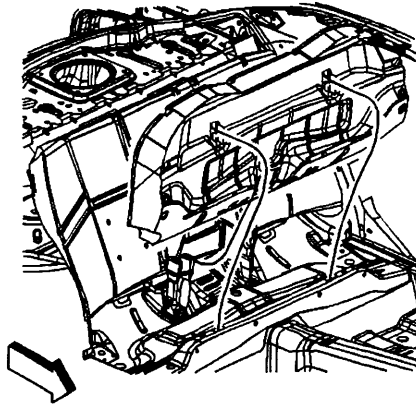

729840

16. Install the rear seat cushion into the vehicle.
17. Engage the center wire hook, on the back of the seat cushion, under the seat back frame.
18. Position the rear seat buckles in the slots of the rear seat cushion.
19. Push down and rearward to seat the rear seat cushion into the latches in the number 4 bar.

Important: Pull up on the front of the rear seat cushion to ensure that the cushion is secure.

20. Use caution while reaching in and turn the ignition switch to the ON position. The AIR BAG indicator will flash and then turn OFF.
21. Perform the SIR diagnostic system check if the AIR BAG warning indicator does not operate as described.

SRX**Removal**

1. Turn the steering wheel so that the vehicle's wheels are pointing straight ahead.
2. Turn the ignition switch to the OFF position.
3. Remove the key from the ignition switch.

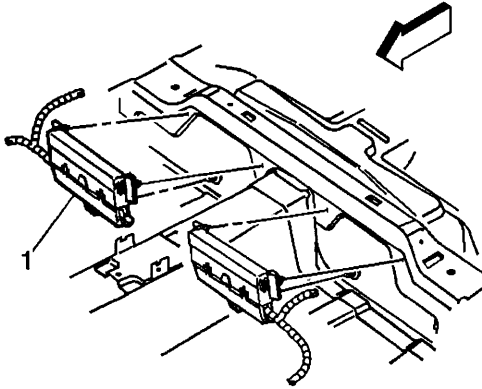

816858

4. Adjust the right rear seat to the rear of the vehicle.
5. Remove the right rear sill plate.
6. Pull the carpet away from under the right side of the rear seat.
7. When the carpet is pulled away from the rear seat, the right rear fuse center (1) will be exposed, then remove the fuse center top cover.

Important: With the SIR fuse removed and the ignition switch in the ON position, the AIR BAG warning indicator illuminates. This is normal operation and does not indicate an SIR system malfunction.

8. Locate and remove the SIR fuse from the right rear fuse center.

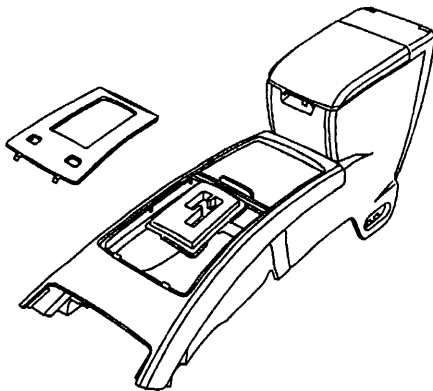

1233706

9. Pry the rear of the shifter trim plate up with a blunt tool to release the trim from the console.
10. Pull upward on the trim plate.

11. Disconnect the traction control electrical connector.
12. Remove the trim plate.

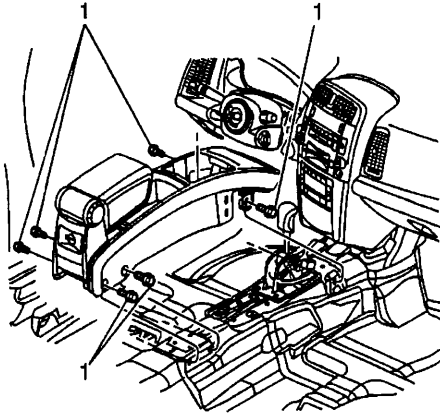

706062

13. Remove the 6 screws (1) securing the console to the floor.

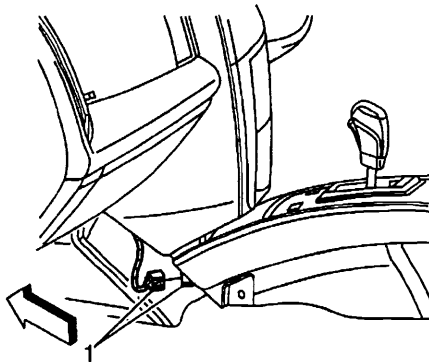

1234124

14. Disconnect the right and left console harness connectors (1).
15. Remove the console from the vehicle.

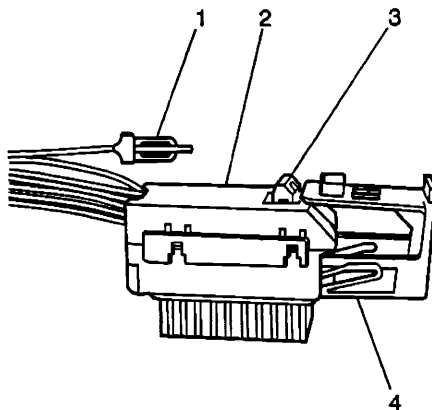

466123

16. Remove the connector position assurance (CPA) (1) from the wiring harness connector (2) to the inflatable restraint sensing and diagnostic module (SDM).

17. Push the flex lock button (3) down and move the sliding connector locking cover (4) to the OPEN position.

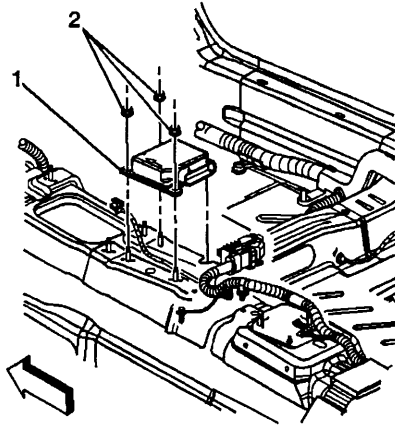

751942

Important: The SDM is shown with the carpet removed for illustration purposes only. Removal of the front carpet or the front seats is not necessary to service the SDM.

18. Disconnect the wiring harness connector from the SDM (1).
19. Remove the SDM mounting fasteners (2).
20. Remove the SDM from the console floor.

Installation

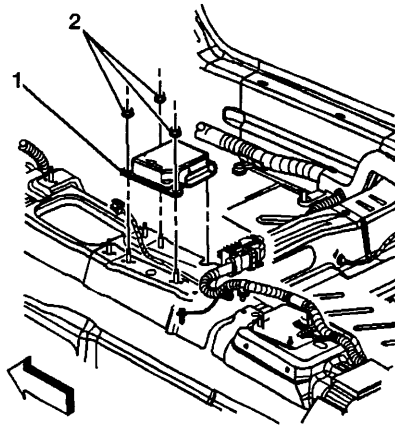

751942

1. Remove any dirt, grease, or other impurities from the mounting surface.
2. Install the SDM (1) horizontally to the console floor.
3. Point the arrow on the SDM toward the front of the vehicle.
4. Install the SDM mounting fasteners (2).

Tighten

Tighten the fasteners to 9 N·m (80 lb in).

5. Connect the wiring harness connector (1) to the SDM.

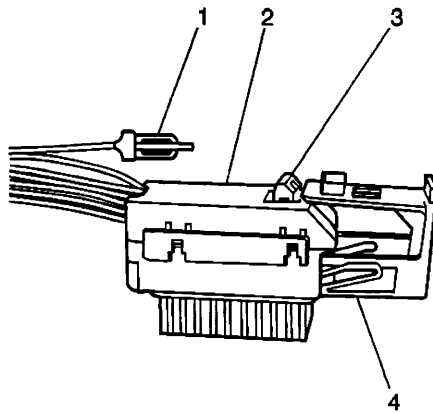

466123

6. Push the flex lock button (3) down and move the sliding connector locking cover (4) to the CLOSE position.
7. Install the CPA (1) to the wiring harness connector (2) to the inflatable restraint SDM.

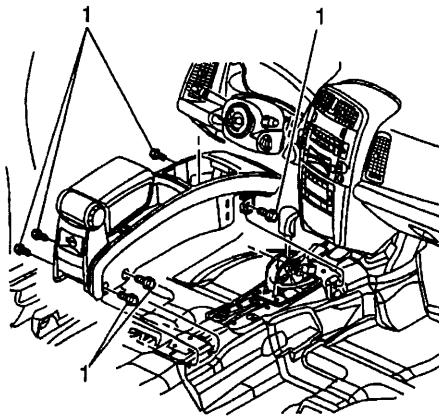

706062

8. Position the console on the floor of the vehicle.

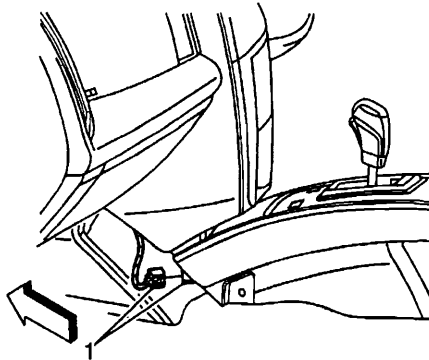

1234124

9. Connect the right and left console harness connectors (1).

10. Install the screws (1) securing the console to the floor.

Tighten

Tighten the fasteners to 25 N·m (18 lb ft).

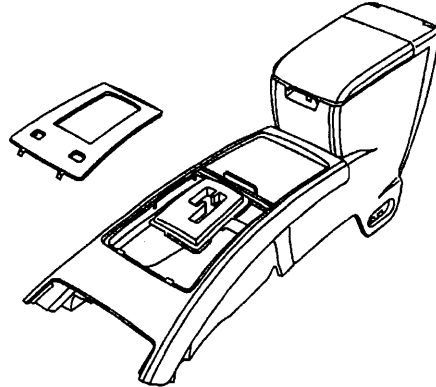

1233706

11. Connect the traction control electrical connector.
12. Install the trim plate to the console with the front tabs.
13. Push down on the rear of the trim plate to lock it onto the console.
14. Install the driver and the passenger seats to the original position.

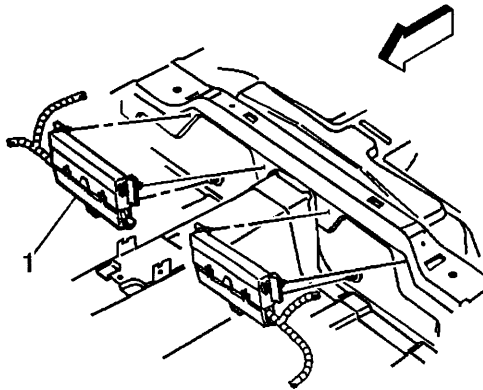

816858

15. Install the SIR fuse into the right rear fuse center (1).
16. Install the right rear fuse center cover.
17. Position the carpet back under the right rear seat.
18. Install the right rear sill plate.
19. Use caution while reaching in and turn the ignition switch to the ON position. The AIR BAG indicator will flash and then turn OFF.
20. Perform the SIR Diagnostic System Check if the AIR BAG warning indicator does not operate as described.

COURTESY TRANSPORTATION

The General Motors Courtesy Transportation Program is intended to minimize customer inconvenience when a vehicle requires a repair that is covered by the New Vehicle Limited Warranty. The availability of courtesy transportation to customers whose vehicles are within the warranty coverage period and involved in a product recall is very important in maintaining customer satisfaction. Dealers are to ensure that these customers understand that shuttle service or some other form of courtesy transportation is available and will be provided at no charge. Dealers should refer to the General Motors Service Policies and Procedures Manual for courtesy transportation guidelines.

CLAIM INFORMATION

Submit a Product Recall Claim with the information indicated below:

| REPAIR PERFORMED | PART COUNT | PART NO. | PARTS ALLOW | CC-FC | LABOR OP | LABOR HOURS |
|--------------------------------------------------------------------------------------------------------|------------|----------|-------------|-------|----------|-------------|
| Replace SDM | 1 | --- | * | MA-96 | V1302 | |
| - CTS Auto | | | | | | 0.6 |
| - CTS Manual | | | | | | 0.5 |
| - SRX | | | | | | 0.6 |
| ----- | | | | | | ----- |
| Add: SIR Diagnostic Check | | | | | | 0.2 |
| Courtesy Transportation for vehicles within the New Vehicle Limited Warranty (U.S. & Canadian Dealers) | N/A | N/A | N/A | MA-96 | ** | N/A |

* The "Parts Allowance" should be the sum total of the current GMSPO Dealer net price plus applicable Mark-Up or Landed Cost Mark-Up (for Export) for the module needed to complete the repair.

** Submit courtesy transportation using normal labor operations for courtesy transportation as indicated in the GM Service Policies and Procedures Manual for vehicles within the New Vehicle Limited Warranty.

Refer to the General Motors WINS Claims Processing Manual for details on Product Recall Claim Submission.

CUSTOMER NOTIFICATION – For US and CANADA

General Motors will notify customers of this recall on their vehicle (see copy of customer letter included with this bulletin).

CUSTOMER NOTIFICATION – For Export

Letters will be sent to known owners of record located within areas covered by the US National Traffic and Motor Vehicle Safety Act. For owners outside these areas, dealers should notify customers using the attached sample letter.

DEALER RECALL RESPONSIBILITY – For US and Export (US States, Territories, and Possessions)

The US National Traffic and Motor Vehicle Safety Act provides that each vehicle that is subject to a recall of this type must be adequately repaired within a reasonable time after the customer has tendered it for repair. A failure to repair within sixty days after tender of a vehicle is prima facie evidence of failure to repair within a reasonable time. If the condition is not adequately repaired within a reasonable time, the customer may be entitled to an identical or reasonably equivalent vehicle at no charge or to a refund of the purchase price less a reasonable allowance for depreciation. To avoid having to provide these burdensome remedies, every effort must be made to promptly schedule an appointment with each customer and to repair their vehicle as soon as possible. In the recall notification letters, customers are told how to contact the US National Highway Traffic Safety Administration if the recall is not completed within a reasonable time.

DEALER RECALL RESPONSIBILITY - ALL

All unsold new vehicles in dealers' possession and subject to this recall must be held and inspected/repaired per the service procedure of this recall bulletin before customers take possession of these vehicles.

Dealers are to service all vehicles subject to this recall at no charge to customers, regardless of mileage, age of vehicle, or ownership, from this time forward.

Customers who have recently purchased vehicles sold from your vehicle inventory, and for which there is no customer information indicated on the dealer listing, are to be contacted by the dealer. Arrangements are to be made to make the required correction according to the instructions contained in this bulletin. A copy of the customer letter is provided in this bulletin for your use in contacting customers. Recall follow-up cards should not be used for this purpose, since the customer may not as yet have received the notification letter.

In summary, whenever a vehicle subject to this recall enters your vehicle inventory, or is in your dealership for service in the future, you must take the steps necessary to be sure the recall correction has been made before selling or releasing the vehicle.



May 2005

Dear General Motors Customer:

This notice is sent to you in accordance with the requirements of the National Traffic and Motor Vehicle Safety Act.

Reason For This Recall: General Motors has decided that a defect, which relates to motor vehicle safety, exists in certain 2004 model year Cadillac CTS, CTS-V, and SRX vehicles. An interaction between the sensing and diagnostic module (SDM) and the vehicle's electrical system in these vehicles may cause the driver's frontal airbag and/or roof-mounted side impact airbag to deploy when the ignition key is turned to the ON position. A person positioned for driving may receive minor injuries such as abrasions from contact with a deploying airbag.

What Will Be Done: Your GM dealer will replace the SDM. This service will be performed for you at **no charge**.

How Long Will The Repair Take? This service correction will take approximately 30 to 50 minutes. However, due to service scheduling requirements, your dealer may need your vehicle for a longer period of time.

Contacting Your Dealer: To limit any possible inconvenience, we recommend that you contact your dealer as soon as possible to schedule an appointment for this repair. By scheduling an appointment, your dealer can ensure that the necessary parts will be available on your scheduled appointment date. Should your dealer be unable to schedule a service date within a reasonable time, you should contact the appropriate Customer Assistance Center at the listed number below. The Customer Assistance Center's hours of operation are from 8:00 AM to 11:00 PM, EST, Monday through Friday.

| Division | Number | Text Telephones (TTY) |
|-----------------------|----------------|-----------------------|
| Cadillac | 1-866-982-2339 | 1-800-833-2622 |
| Puerto Rico – English | 1-800-496-9992 | |
| Puerto Rico – Español | 1-800-496-9993 | |
| Virgin Islands | 1-800-496-9994 | |
| Guam | 1-671-648-8650 | |

If, after contacting the appropriate Customer Assistance Center, you are still not satisfied that we have done our best to remedy this condition without charge and within a reasonable time, you may wish to write the Administrator, National Highway Traffic Safety Administration, 400 Seventh Street, SW, Washington, DC 20590 or call 1-888-327-4236.

Customer Reply Form: The enclosed customer reply form identifies your vehicle. Presentation of this form to your dealer will assist in making the necessary correction in the shortest possible time. If you no longer own this vehicle, please let us know by completing the form and mailing it back to us.

Courtesy Transportation: If your vehicle is within the New Vehicle Limited Warranty your dealer may provide you with shuttle service or some other form of courtesy transportation while your vehicle is at the dealership for this repair. Please refer to your Owner's Manual and your dealer for details on Courtesy Transportation.

My GMLink Online: This free online service offers vehicle and ownership related information and tools tailored to your specific vehicle. To join, visit www.mygmlink.com, and enter your vehicle's 17-character vehicle identification number (VIN) shown on the enclosed customer reply form to get the most personalized information for your vehicle.

Federal regulation requires that any vehicle lessor receiving this recall notice must forward a copy of this notice to the lessee within ten days.

We are sorry to cause you this inconvenience; however, we have taken this action in the interest of your safety and continued satisfaction with our products.

General Motors Corporation

Enclosure
05004