

May 20, 2005

OSE-035

Dear Service Manager:

Honda Motor Co., LTD has announced a safety recall campaign for a limited number of 2005 Elements equipped with an accessory trailer hitch.

The wire harness of the trailer hitch kit has an incorrectly wired connector. As a result, the trailer brake lights and turn signal lights could operate incorrectly, or a fuse could blow, causing a sudden loss of brake light and turn signal light function. Improper signaling or a loss of trailer warning light function without warning could cause a crash.

Customer Notification

Notifications to all owners will be mailed May 23–24.

Affected Vehicles

For the affected VINs, refer to Service Bulletin 05-024, *Safety Recall: Accessory Trailer Hitch Is Incorrectly Wired*. Only about 450 vehicles within the VIN range are potentially affected. Before beginning work on a vehicle, verify its eligibility by checking at least one of these items:

- The customer has a notification letter.
- The vehicle is shown as eligible on an iN VIN status inquiry.

Some vehicles affected by this recall are in your new vehicle inventory. **According to federal law, these vehicles cannot be sold or leased until they are repaired.** To see if a vehicle is potentially affected by this recall, do a VIN status inquiry before selling it.

Repair Strategy

If the vehicle is equipped with an accessory trailer hitch, the repair is to reposition the terminals in the trailer hitch wire harness connector, and reseal the connector with EPT Sealer 5T. If the vehicle is **not** equipped with an accessory trailer hitch, either you or your customer must fill out and return a postage-paid *Safety Recall Response Card* to remove the vehicle from this recall. We supplied your dealership with a small quantity of these response cards; the cards were also sent to customers along with the recall notification.

For repair and warranty information, refer to S/B 05-024.

Parts Information

No parts are needed to complete this recall. The EPT sealer tape used in the repair is available through normal channels.

Sincerely,

**American Honda Motor Co., Inc.
Honda Automobile Division**



Applies To: 2005 Element – From VIN 5J6YH...5L000001 thru 5J6YH...5L016013

May 20, 2005

Safety Recall: Accessory Trailer Hitch Is Incorrectly Wired

BACKGROUND

The wire harness of the accessory trailer hitch kit has an incorrectly wired connector. As a result, the trailer brake and turn signal lights could operate incorrectly, or a fuse could blow, causing a sudden loss of brake and turn signal lights. Improper signaling or a loss of trailer brake light function without warning could cause a crash.

CUSTOMER NOTIFICATION

All owners of potentially affected vehicles will be sent a notification of this campaign. An example of the customer notification is at the end of this service bulletin.

Only about 450 vehicles within the VIN range are affected. To verify vehicle eligibility, check at least one of these items:

- The customer has a notification letter.
- The vehicle is shown as eligible on an iN VIN status inquiry.

Some vehicles affected by this campaign are in your new vehicle inventory. **According to federal law, these vehicles cannot be sold or leased until they are repaired.** To see if a vehicle is potentially affected by this campaign, do a VIN status inquiry before selling it.

CORRECTIVE ACTION

If the vehicle is equipped with a Genuine Honda trailer hitch, reposition the terminals in the trailer hitch wire harness connector (see **REPAIR PROCEDURE**).

If the vehicle is **not** equipped with a Genuine Honda trailer hitch, either you or your customer must fill out and return a postage-paid *Safety Recall Response Card* to remove the vehicle from this recall. We supplied your dealership with a small quantity of these response cards; the cards were also sent to customers along with the recall notification.

TOOL INFORMATION

Terminal Pin Tool Set: T/N 07JAZ-002000A

REQUIRED MATERIALS

EPT Sealer 5T: P/N 06991-SA5-000, H/C 2086650
(One roll repairs about 12 vehicles)

WARRANTY CLAIM INFORMATION

OP#	Description	FRT	TemplateID
7370A4	Vehicle with a Genuine Honda trailer hitch: Reposition the terminals in the trailer hitch wire harness connector	0.2	05-024A
	Vehicle without a Genuine Honda trailer hitch: Return Safety Recall Response card		05-024B

Failed Part: P/N 08L91-SCV-102
H/C 7948169

Defect Code: 5ET00

Symptom Code: P7800

Skill Level: Repair Technician

REPAIR PROCEDURE

1. Open the hatch and the tailgate.
2. Remove the cargo area floor.
3. Peel off any EPT sealer tape from the vehicle/trailer wire harness 4P connector, then disconnect the connector.

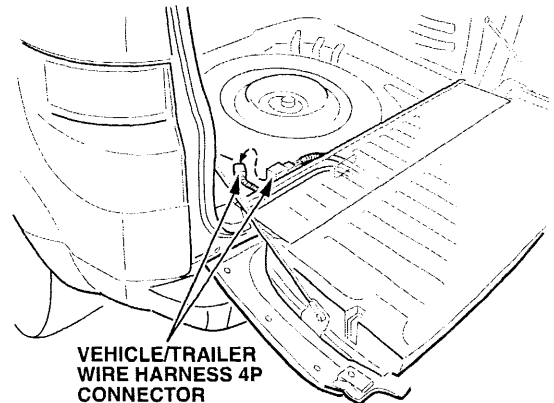

- Detach the trailer side of the connector (male terminal side), then remove the connector lock from the connector using needle-nose pliers.

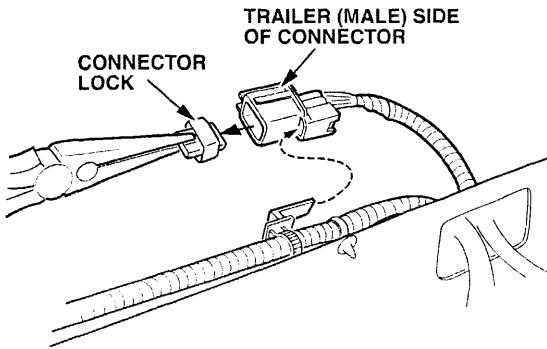

- Using a terminal pin tool or a narrow blade flat-tip screwdriver, remove the four terminals from the connector.

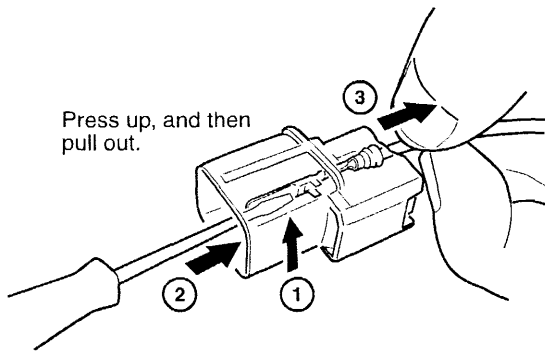

- Reinsert the terminals in these positions in the connector:
 - White wire*: Top left
 - Brown wire*: Top right
 - Yellow wire*: Bottom left
 - Green wire*: Bottom right

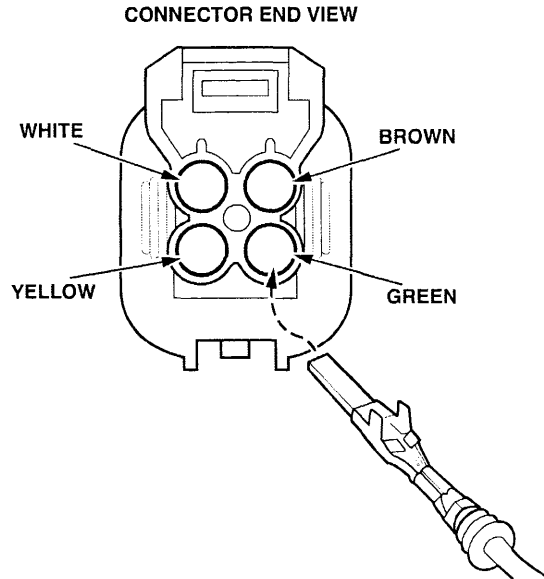

- Gently pull on each wire to make sure the terminals are secure. Reinstall the connector lock, and reconnect the connector.
- Using a test light or a multimeter, check for these readings at the terminals on the trailer-end of the wire harness:
 - White wire*: Ground
 - Brown wire*: Battery voltage with headlights on.
 - Yellow wire*: Battery voltage with left turn signal on or brake pedal pressed.
 - Green wire*: Battery voltage with right turn signal on or brake pedal pressed.
- Reinstall the harness, and replace any wire ties you may have cut.
- Wrap the connector with a 50 mm x 150 mm piece of EPT sealer tape.

Example of Customer Letter

May 2005

**Safety Recall: Accessory Trailer Hitch is
Incorrectly Wired**

Dear Element Owner:

This notice is sent to you in accordance with the requirements of the National Traffic and Motor Vehicle Safety Act.

What is the reason for this notice?

Honda Motor Co., Ltd., has decided that a defect relating to motor vehicle safety exists in certain Honda accessory trailer hitch kits sold for 2005 model year Elements. The wire harness of the trailer hitch kit has an incorrectly wired connector. As a result, the trailer brake and turn signal lights could operate incorrectly, or a fuse could blow, causing a sudden loss of brake and turn signal lights. Improper signaling or a loss of trailer brake light function without warning could cause a crash.

What should you do?

If your Element is equipped with a Genuine Honda trailer hitch:

Call any authorized Honda dealer, and make an appointment to have your trailer hitch wire harness inspected. The dealer will confirm that the trailer hitch is a Honda accessory and correct the connector wiring, *free of charge*. Please plan to leave your vehicle for half a day to allow the dealer flexibility in scheduling.

*If your Element is **not** equipped with a Genuine Honda trailer hitch:*

Your vehicle is not affected by this recall. Please fill out and return the enclosed, postage-paid *Customer Response Card*. If you do not return the response card, you will continue to receive reminders of this recall in the mail.

Who to contact if you experience problems.

If you are not satisfied with the service you receive from your Honda dealer, you may write to:

American Honda Motor Co., Inc.
Honda Automobile Customer Service
Mail Stop 500-2N-7A
1919 Torrance Blvd.
Torrance, CA 90501-2746

If you believe that American Honda or the dealer has failed or is unable to remedy the defect in your vehicle, without charge, within a reasonable period of time (60 days from the date you first contact the dealer for a repair appointment), you may submit a complaint to:

Administrator
National Highway Traffic Safety Administration
400 Seventh Street, SW
Washington, DC 20590

Or call the toll-free Safety Hotline at (888) 327-4236.

What to do if you feel this notice is in error.

Our records show that you are the current owner or lessee of a 2005 Element involved in this campaign. If this is not the case, or the name/address information is not correct, please fill out and return the enclosed, postage-paid *Information Change Card*. We will then update our records.

Lessor Information.

Federal law requires that any vehicle lessor receiving this recall notice must forward a copy of this notice to the lessee within 10 days.

If you have questions.

If you have any questions about this notice, or need assistance with locating a Honda dealer, please call Honda Automobile Customer Service at (800) 999-1009.

We apologize for any inconvenience this campaign may cause you.

Sincerely,

**American Honda Motor Co., Inc.
Honda Automobile Division**