



MITSUBISHI FUSO

TRUCK OF AMERICA, Inc.

2015 Center Square Road

Logan Twp., NJ 08085

(856) 467-4500

(856) 467-4695 Fax

June 28, 2005

Christina Morgan, Chief
Early Warning Division
Office of Defects Investigation, Safety Assurance
U.S. Department of Transportation
National Highway Traffic Safety Administration, Room 5219
400 Seventh Street, S.W.
Washington, DC 20590

**Subject: Mitsubishi Fuso Truck & Bus Corporation Foreign Recall Notification
(Substantially Similar Vehicle)**

Dear Ms. Morgan:

On June 21, 2005, Mitsubishi Fuso Truck and Bus Corporation (MFTBC), Japan advised Mitsubishi Fuso Truck of America, Inc. (MFTA) that MFTBC has decided to conduct a safety recall campaign in foreign countries involving vehicles that are substantially similar to vehicles offered for sale in the United States. Please see the details of the foreign recall below:

1. Manufacturer's Name
Mitsubishi Fuso Truck & Bus Corporation (MFTBC), Japan
2. Identification of Vehicles/Production Period
 - FE639, FE640, FE649, FE659, FG639, FH210
 - Production period: Japan: February 27, 1998 to January 20, 2004
3. Number of Vehicles Involved:
15,901 units (Japan: 0; Export: 15,901)

4. Defect Description

On affected vehicles, rust build-up on the A/T shift linkage, due to an insufficient corrosion inhibiting ability, may cause the linkage to bind. Rust build-up is accelerated in geographic locations that are situated near large bodies of salt water, or in regions with heavy snow/ice melting compound usage in winter months. The effort required to operate the A/T shift control lever may increase if the linkage binds due to rust build-up. In the worst case, the shift control lever may become inoperative, or the transmission gear position indicated on the instrument panel may not match the actual gear selection at the transmission.

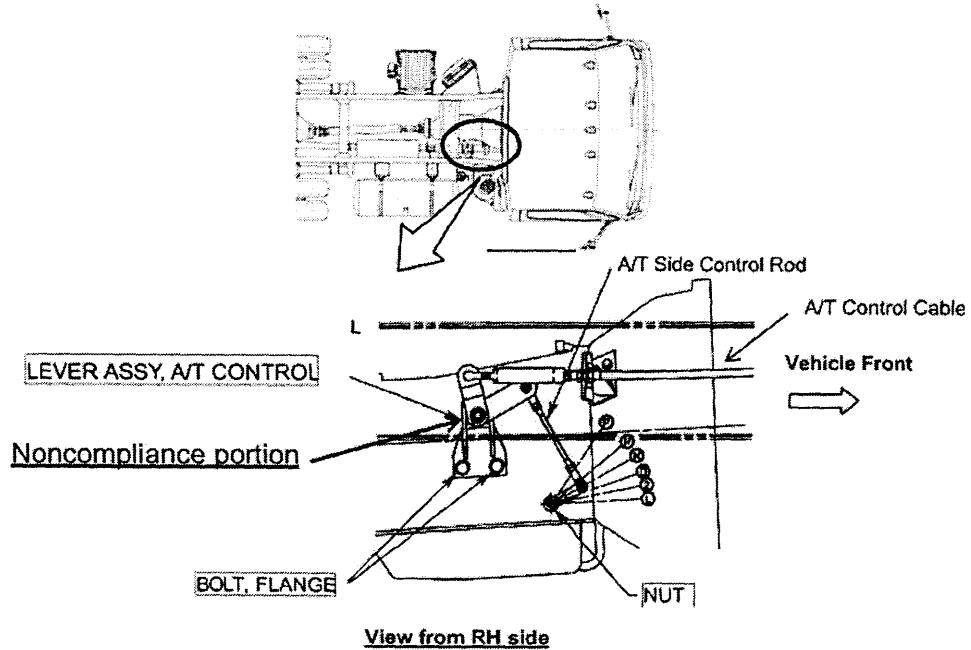

5. Foreign countries where safety recall will be launched:

Country	Units
USA	15,895
TAIWAN	5
EGYPT	1
Total	15,901

6. Safety Recall or other Safety Campaign:

Recall Campaign

7. Recall determination, government or manufacturer:

Manufacturer

8. Remedy

Replacement of the A/T shift control lever with a modified assembly.

9. Date Campaign will start:

As no vehicles in the Japan market are affected by this recall, MFTBC is not required to file this recall campaign with the MLIT. The campaign start date has not yet been fixed. MFTA is preparing to conduct a safety recall in the U.S.

10. Substantially Similar Vehicles:

In the Japan domestic truck market, the truck model year is not used to identify the vehicle. The trucks are referenced by production date and chassis number only. The trucks do not have a "VIN" number as we do in the U.S. Instead, the chassis number includes the engine serial number, the vehicle model code, and the production date.

The Truck models offered for sale in the U.S. by MFTA that are substantially similar to the trucks involved in this campaign are the 1996-2004 FE639, 2001-2004 FE640, 1996-2004 FE649, 1998-2004 FG639, and the 2003-2004 FH210. **Please Note: MFTBC trucks manufactured in Japan and offered for sale by MFTA in the U.S. use the same A/T shift control linkage, and are affected by this recall. MFTA currently is preparing to conduct a safety recall in the U.S.**

If you have any questions or concerns, please do not hesitate to contact me at the number listed below.

Sincerely,



William P. Mohr
Director, Service Operations
Mitsubishi Fuso Truck of America, Inc.
Phone: (856) 467-3917 Fax: (856) 467-4665

c: K. Idota (MFTBC)
Y. Sato (MFTBC)
N. Nakajima (MFTBC)