

April 2005

Dear General Motors Customer:

This notice is sent to you in accordance with the requirements of the National Traffic and Motor Vehicle Safety Act.

Reason For This Recall: General Motors has decided that certain 2005 Pontiac G6 vehicles fail to conform to Federal Motor Vehicle Safety Standard 225 requirements for child restraint lower anchorage location and owner manual information for the rear center seat. Without additional owner manual information, an owner may encounter difficulty in installing child restraints with rigid attachments in the center position.

If difficulty is encountered when trying to secure a child restraint in the rear center seating position, the restraint should be moved to either outboard seating positions.

What Will Be Done: We have enclosed an owner manual update that describes the location and proper use of the anchorages in all three rear seating positions. Please review this information and then place it in your owner manual for future reference.

Contacting Your Dealer: If you have any questions, contact your dealer or the appropriate Customer Assistance Center at the listed number below. The Customer Assistance Center's hours of operation are from 8:00 AM to 11:00 PM, EST, Monday through Friday.

Division	Number	Text Telephones (TTY)
Pontiac	1-800-620-7668	1-800-833-7668
Puerto Rico – English	1-800-496-9992	
Puerto Rico – Español	1-800-496-9993	
Virgin Islands	1-800-496-9994	
Guam	1-671-648-8650	

If, after contacting your dealer or the appropriate Customer Assistance Center, you are still not satisfied that we have done our best to remedy this condition without charge and within a reasonable time, you may wish to write the Administrator, National Highway Traffic Safety Administration, 400 Seventh Street, SW, Washington, DC 20590 or call 1-888-327-4236.

Owner Center Online: This free online service offers vehicle and ownership related information and tools tailored to your specific vehicle. To get the most personalized information for your vehicle, visit www.mygmink.com, and enter your vehicle's 17-character vehicle identification number (VIN) shown on the enclosed customer reply form.

Federal regulation requires that any vehicle lessor receiving this recall notice must forward a copy of this notice to the lessee within ten days.

We are sorry to cause you this inconvenience; however, we have taken this action in the interest of your safety and continued satisfaction with our products.

General Motors Corporation

Enclosure
05005

This information replaces the information found in your owner manual under the headings *Where to Put the Restraint, Top Strap Anchor Location, Lower Anchorages and Top Tethers for Children (LATCH System), and Securing a Child Restraint Designed for the LATCH System.*

Where to Put the Restraint

Accident statistics show that children are safer if they are restrained in the rear rather than the front seat. General Motors recommends that child restraints be secured in a rear seat, including an infant riding in a rear-facing infant seat, a child riding in a forward-facing child seat and an older child riding in a booster seat.

Your vehicle has a rear seat that will accommodate a rear-facing child restraint. A label on your sun visor says, "Never put a rear-facing child seat in the front." This is because the risk to the rear-facing child is so great, if the airbag deploys.

Caution: A child in a rear-facing child restraint can be seriously injured or killed if the right front passenger's airbag inflates. This is because the back of the rear-facing child restraint would be very close to the inflating airbag.

Even though the passenger sensing system is designed to turn off the passenger's frontal airbag if the system detects a rear-facing child restraint, no system is fail-safe, and no one can guarantee that an airbag will not deploy under some unusual circumstance, even though it is turned off. General Motors recommends that rear-facing child restraints be secured in the rear seat, even if the airbag is off.

If you need to secure a forward-facing child restraint in the right front seat, always move the front passenger seat as far back as it will go. It is better to secure the child restraint in a rear seat.

If you need to secure more than one child restraint in the rear seat, review the following illustrations. Depending on where you place the child restraint, you may not be able to access certain safety belt assemblies or LATCH anchors for additional passengers or child restraints.

Configurations for Use of Child Restraints

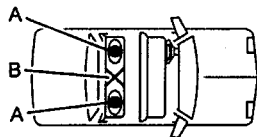

- A. Child restraint using LATCH
- B. Child restraint or occupant using safety belt

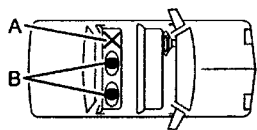

- A. Occupant prohibited
- B. Child restraint using LATCH

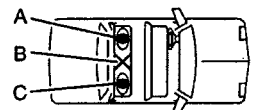

- A. Child restraint using LATCH
- B. Child restraint or occupant using safety belt
- C. Child restraint using safety belt or LATCH or occupant using safety belt

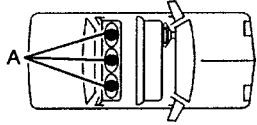

A. Child restraint or occupant using safety belt

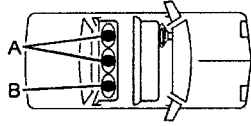

A. Child restraint or occupant using safety belt

B. Child restraint using LATCH

Wherever you install a child restraint, be sure to secure the child restraint properly.

Keep in mind that an unsecured child restraint can move around in a collision or sudden stop and injure people in the vehicle. Be sure to properly secure any child restraint in your vehicle — even when no child is in it.

Top Strap Anchor Location

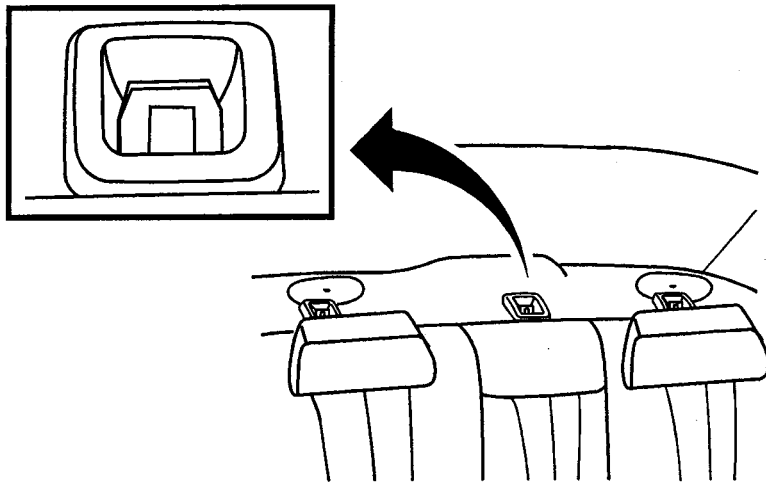

Your vehicle has top strap anchors for the rear seating positions. The anchors are located on the filler panel behind the rear seat head restraints.

If your vehicle has adjustable head restraints, pull up the head restraint to access the anchors. The straps from the child restraint must be threaded between the poles of the head restraint on the seat. The strap must not go around the head restraint.

Do not secure a child restraint in the right front passenger's position if a national or local law requires that the top strap be anchored, or if the instructions that come with the child restraint say that the top strap must be anchored. There is no place to anchor the top strap in this position.

Lower Anchorages and Top Tethers for Children (LATCH System)

Your vehicle has the LATCH system. There are anchors for all three rear seating positions. The anchors are located between the seatback and the seat cushion. There is a specific way to attach a child restraint to the anchors in the three possible positions.

If you need to secure more than one child restraint in the rear seat see *Where to Put the Restraint*. Depending on where you place the child restraint, you may not be able to access certain safety belt assemblies or LATCH anchors for additional passengers or child restraints.

You cannot secure three child restraints using the LATCH anchors in the rear seat at the same time, but you can install two of them. If you want to do this, install one LATCH child restraint in the passenger-side position, and install the other one either in the driver's-side position or in the center position. Refer to the following illustration to learn which anchors to use.

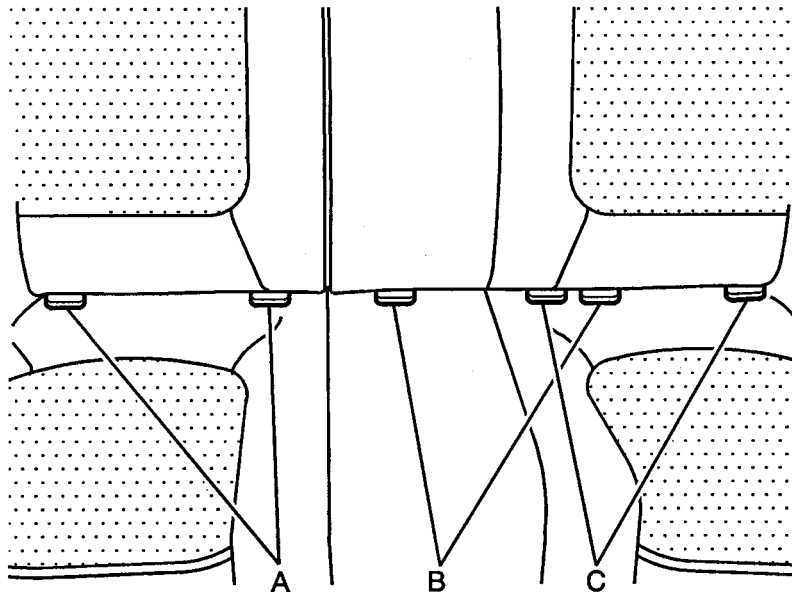

- A. Passenger's-side Rear Seat Lower Anchorages
- B. Center Rear Seat Lower Anchorages
- C. Driver's-side Rear Seat Lower Anchorages

Make sure to attach the child restraint at the proper anchor location.

This system, designed to make installation of child restraints easier, does not use the vehicle's safety belts. Instead, it uses vehicle anchors and child restraint attachments to secure the restraints. Some restraints also use another vehicle anchor to secure a top strap.

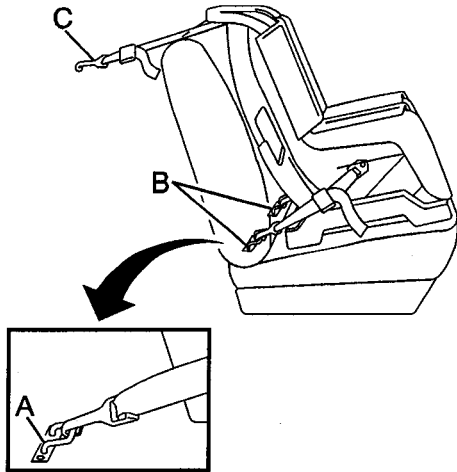

- A. Lower Anchorage
- B. Lower Anchorage
- C. Top Strap

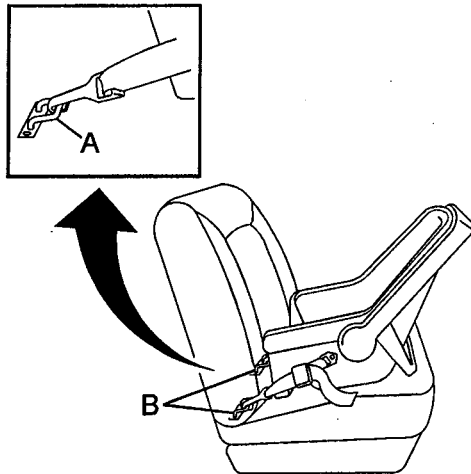

- A. Lower Anchorage
- B. Lower Anchorage

In order to use the LATCH system in your vehicle, you need a child restraint designed for that system.

To assist you in locating the lower anchors for this child restraint system, each seating position with the LATCH system has a label on the seatback at each lower anchor position.



The labels are located near the base of all three rear seating positions.

Caution

If a LATCH-type child restraint is not attached to its anchorage points, the restraint will not be able to protect the child correctly. In a crash, the child could be seriously injured or killed. Make sure that a LATCH-type child restraint is properly installed using the anchorage points, or use the vehicle's safety belts to secure the restraint, following the instructions that came with that restraint, and also the instructions in this manual.

Securing a Child Restraint Designed for the LATCH System

1. Find the LATCH anchorages for the seating position you want to use, where the bottom of the seatback meets the back of the seat cushion. See *Lower Anchorages and Top Tethers for Children (LATCH System)*.
2. Put the child restraint on the seat.
3. Your child seat may be equipped with either rigid or flexible attachments. Flexible attachments are usually attached to material similar to seat belt webbing. Rigid attachments are built into the base of the child restraint. If your child restraint has flexible attachments, attach and tighten the LATCH attachments on the child restraint to the LATCH anchorages in the vehicle. The child restraint instructions will show you how. If your child restraint has rigid attachments, attach them to the LATCH anchors in the vehicle per the manufacturer's instructions. In the center position, you may attach one anchor and then rotate the child restraint to attach the second anchor. If this is too difficult, you may install the child restraint at either of the rear outboard positions or use the vehicle's safety belts to attach the child restraint in the rear center position. See the following section for *Securing a Child Restraint in a Rear Seat Position* in your owner manual.
4. If the child restraint is forward-facing, attach and tighten the top strap, if equipped, to the top strap anchor. Refer to the child restraint instructions and the following steps:
 - 4.1 Find the top strap anchor.
 - 4.2 Route and tighten the top strap according to your child restraint instructions and the following instructions:

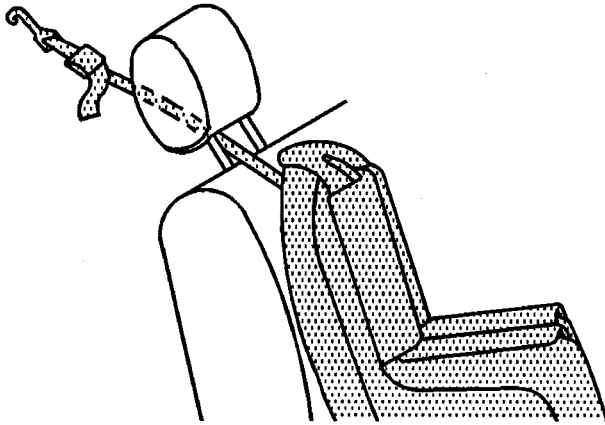

If the position you are using has a head restraint and you are using a single tether, route the tether under the head restraint and in between the head restraint posts.

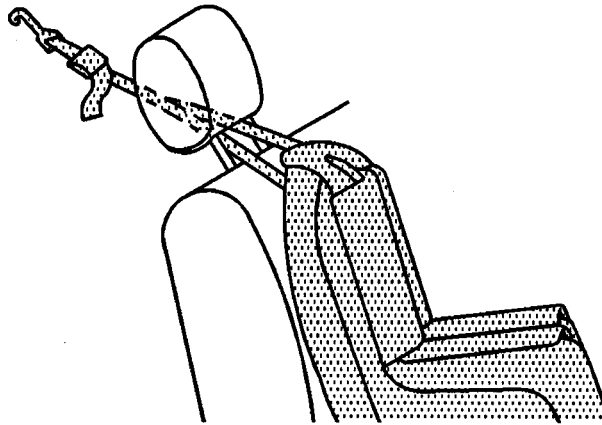

If the position you are using has a head restraint and you are using a dual tether, route the tether under the head restraint and in between the head restraint posts.

4.3 You may have to raise the head restraint to route and tighten the top strap. Be sure to lower the head restraint once the child restraint is secure.

5. Push and pull the child restraint in different directions to be sure it is secure.

To remove the child restraint, simply unhook the top strap from the top strap anchorage and then disconnect the LATCH attachments from the LATCH anchorages.