

NISSAN

NISSAN NORTH AMERICA, INC.

Corporate Office
18501 South Figueroa St.
Gardena, California 90248-4500
Mailing Address: P.O. Box 191
Gardena, California 90248-0191
Telephone: 310.532.3111

October 13, 2005

Mr. George Person
Chief, Recall Analysis Division
Office of Defects Investigation
Safety Assurance
National Highway Traffic Safety Administration
400 Seventh Street, S.W.
Washington, D.C. 20590

Ref: 05V-458

Dear Mr. Person:

The enclosed communication is being provided pursuant to 49 CFR Part 573.6(c)(9).

Technical Compliance Department

Encl.

RECEIVED
NVS-215
2005 OCT 17 P 12:46
OFFICE OF
DEFECTS INVESTIGATION

To: Nissan Owner

From: Nissan North America

Subject: Your Nissan Xterra

Re: VIN #: 5 N 1 A N 0 8 _ _ 5 C - 6 _ _ _ _ _

Thank you for purchasing or leasing the 2005 Xterra, a vehicle designed to function both on the road and off the road for those adventures you might be looking forward to.

In our continuing effort to ensure your safety and the safety of your passengers and others, Nissan became aware of a potential safety defect with the tow hitch on some 2005 Xterra vehicles. As a result, we initiated a Safety Recall Campaign to replace the tow hitch on the affected vehicles.

Your vehicle originally had a tow hitch installed by Nissan. As a safety precaution, this tow hitch has been removed from your vehicle and we will replace it with a new one redesigned by Nissan. However, we have only just started to manufacture the new hitches and have not yet been able to get one to your dealer for your new Xterra. As soon as a new tow hitch becomes available, you will be notified to schedule an appointment and have the new hitch installed on your vehicle (there will be no charge to you for the hitch or for labor).

Consider this document a "due bill" stating that a genuine Nissan accessory tow hitch is included in the purchase price of your 2005 Xterra and that you are entitled to free installation of the new hitch when it becomes available. You can expect to be notified to have the new tow hitch installed within the next 30-45 days or so. Please present this "due bill" at that time.

Again, thank you for your purchase or lease of a new 2005 Xterra. We sincerely apologize for any inconvenience this may cause.

Nissan North America
Nissan Division

Authorized Nissan Dealer Signature: _____

Date: ___ / ___ / _____

Subject: 2005 Xterra Tow Hitch Voluntary Safety Recall Campaign Update #3

Attention – Dealer Principals, Sales, Parts and Service Managers

The following is an update for this campaign.

******* Retail Sale of Affected Vehicles *******

Removing the tow hitch from the vehicle effectively eliminates the defect and the vehicle can then be retailed in compliance with Federal regulations. However, when retailing a vehicle with a removed Nissan Factory Installed Accessory Tow Hitch, it is the Nissan dealer's responsibility to inform the buyer that the hitch was removed and to provide a due-bill which will be redeemable upon dealership receipt of a new hitch from Nissan.

To assist dealers with this process, Nissan has developed a "due bill" which can be used as a standalone document or be used to support your current due bill process.

A copy of the due bill is available on NNA.net.com under My Documents under the Sales/Campaigns category. The document is named 2005 Xterra Tow Hitch Due Bill.

******* Owner Notification *******

Nissan will be notifying ALL 2005 Xterra owners by mid-October to advise them (if a Nissan Accessory Tow Hitch is currently installed on their vehicle) not to use the hitch until a replacement hitch is provided by Nissan.

For owners who do NOT have a Nissan Tow Hitch installed, Nissan is asking owners to return a postcard stating that the specified hitch is NOT installed. Owners who return the postcard will not receive any further communication from Nissan.

At a future date, as replacement hitches becomes available, Nissan will conduct a second mailing and instruct owners to schedule an appointment to have the replacement hitch installed.

Nissan dealers will receive additional direction as soon as replacement hitches become available.

******* Additional Updates *******

The Connector Plug Sets are being provided to Nissan dealers free of charge. Do not submit a claim for this P/N. In lieu of dealer parts mark-up, Nissan has provided an Expense Code (565) for dealers to submit.

If additional Connector Plug Sets are needed, the e-mail address specified in the Interim Repair Instructions under Parts Information has been changed to campaign.parts@nissan-usa.com.

If you have any additional questions related to this program, please contact your Dealer Parts and Service Manager (DPSM).

Nissan Parts and Service Operations
10/12/2005

INTERIM REPAIR INSTRUCTIONS 2005 XTERRA TOW HITCH REMOVAL / DISPOSITION

- Revised 10/12/05 -

SERVICE PROCEDURE

Remove the Tow Hitch as follows:

1. Remove or lower the Spare Tire/Wheel using the Hand Crank tools from the tool kit (see Figure 1).

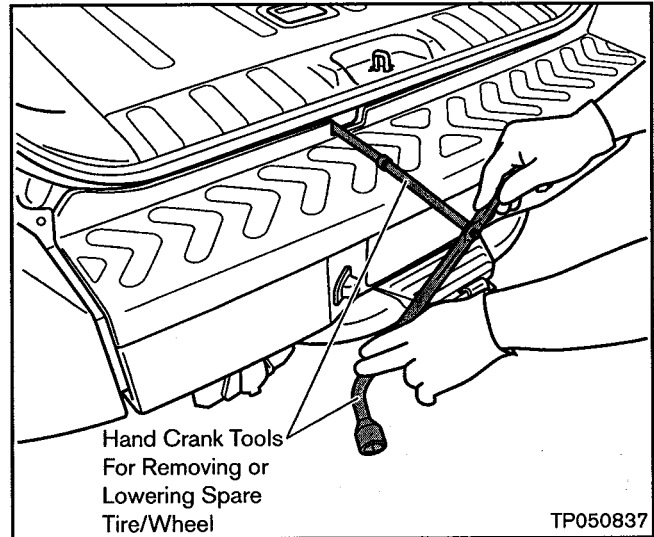

Figure 1

2. Lift the vehicle UP on a hoist.

3. Cut and discard the Tie Wrap that holds the Trailer Lights Wiring Harness Connectors (see Figure 2).

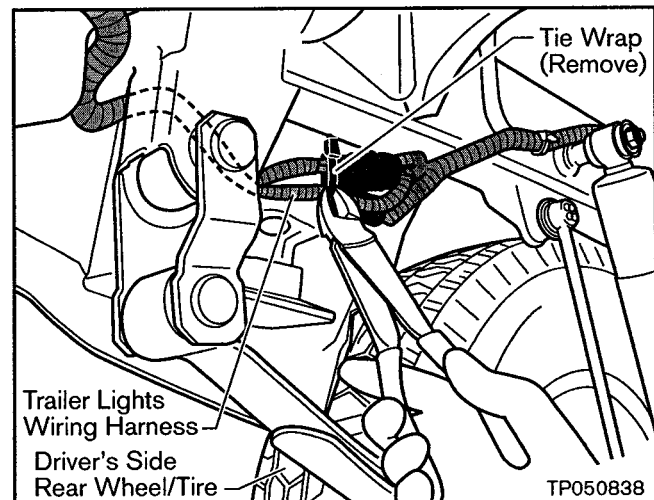

Figure 2

4. Disconnect the Trailer Lights Wiring Harness Connectors (see Figure 3).

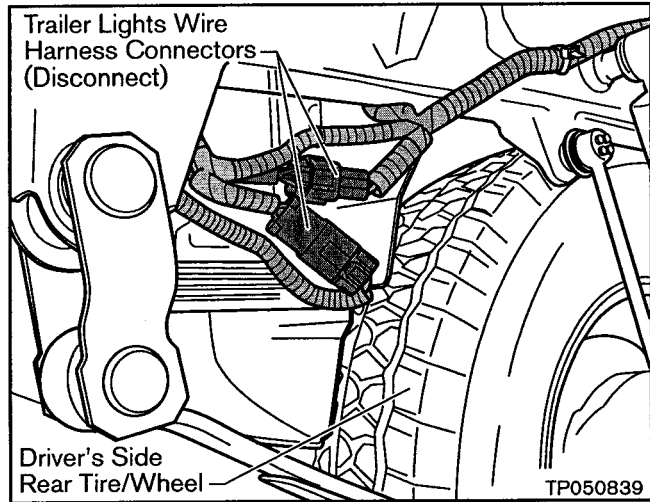

Figure 3

5. Install Plastic Connector Plugs into the vehicle side of the Trailer Lights Wiring Harness Connectors (see Figure 4).
- Nissan will send the Connector Plugs directly to your dealership.
 - To obtain additional Connector Plugs, see Parts Information.

CAUTION: Failure to install the Plugs could allow contamination of the electrical terminals and may affect vehicle electrical system functions.

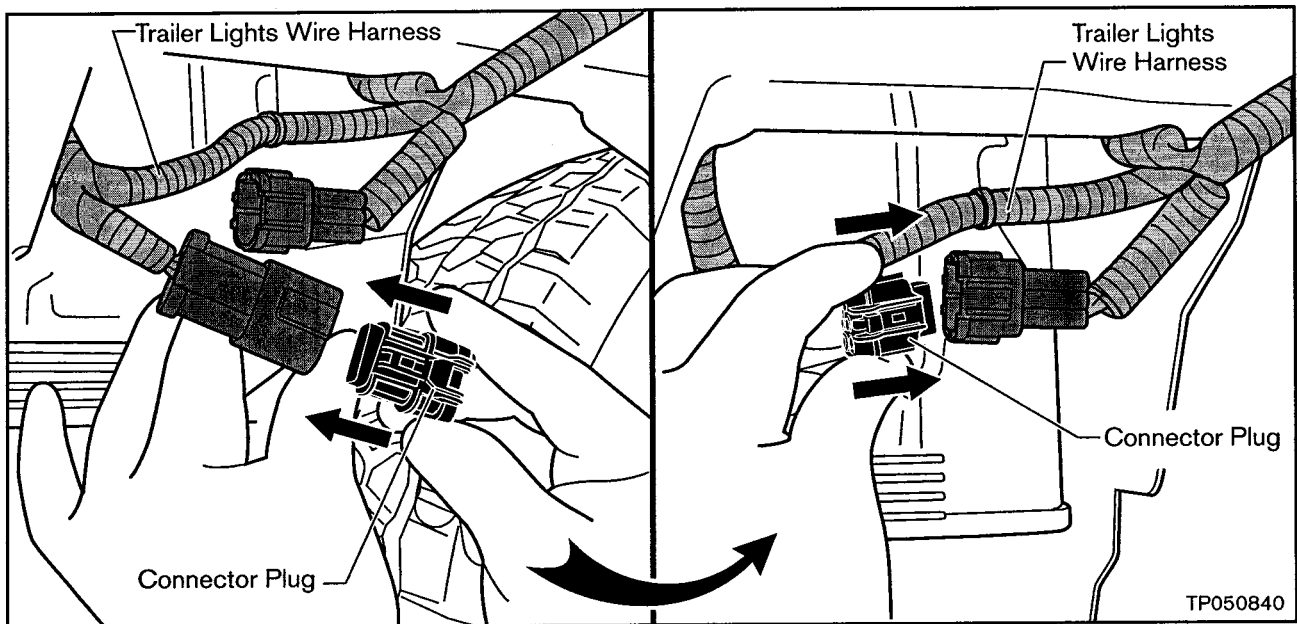

Figure 4

6. After the Connector Plugs are installed, secure the Black Connector to the harness with a Tie Wrap as shown in Figure 5.

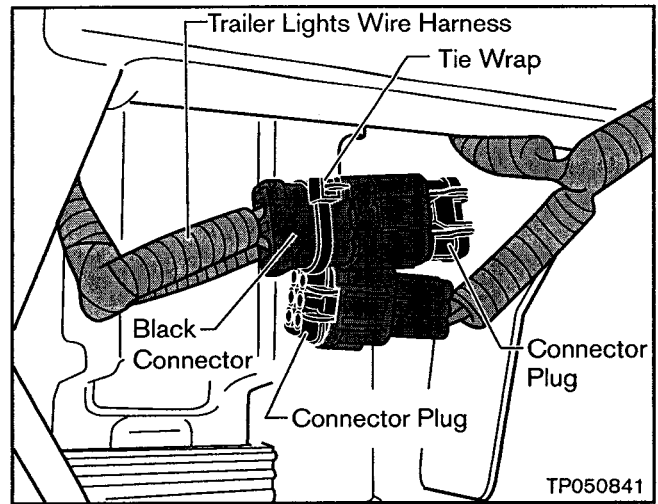

Figure 5

7. Remove the Trailer Lights Wire Harness (Tow Hitch side) from the vehicle as follows:
- Using a suitable pry tool, remove the Harness Tie Wraps from the Frame and Leaf Spring Support (see Figure 6). These Tie Wraps may get damaged during removal.
 - Using needle-nose pliers, release the Harness Tie Wraps from the Tow Hitch (these Tie Wraps will be used again later).
 - Allow the Harness to hang from the Tow Hitch.

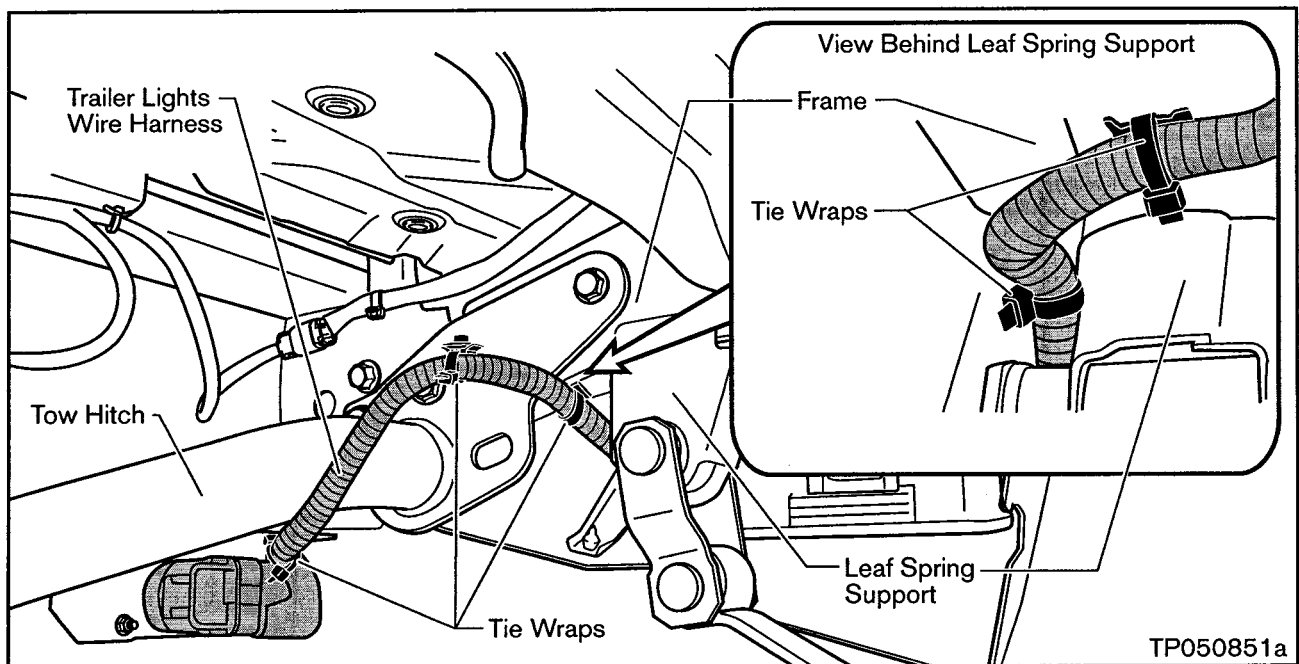

Figure 6

d. Remove two Bolts/Nuts and remove (slide DOWN) the Trailer Lights Wire Harness Receptacle from the Tow Hitch (see Figure 7).

- Once the receptacle is removed, re-install the Bolts/Nuts back into the Receptacle.
- The Bolts/Nuts will be used again later.

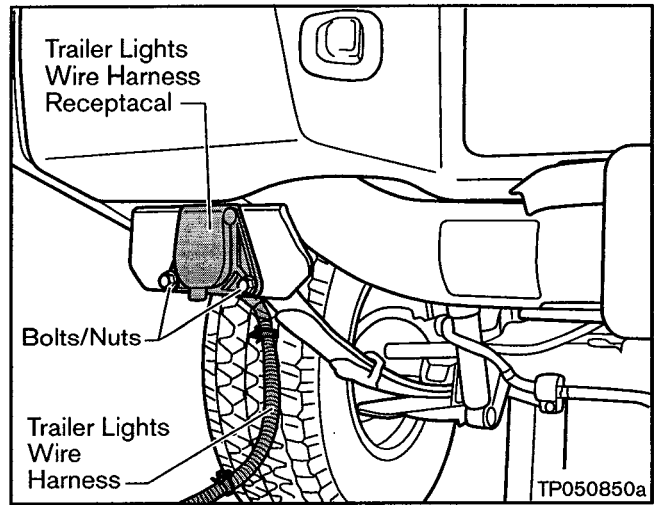

Figure 7

8. Place the removed Trailer Lights Wire Harness in a sealed plastic bag with the VIN written on the bag (see Figure 8).

- Hold on to the bag for now.

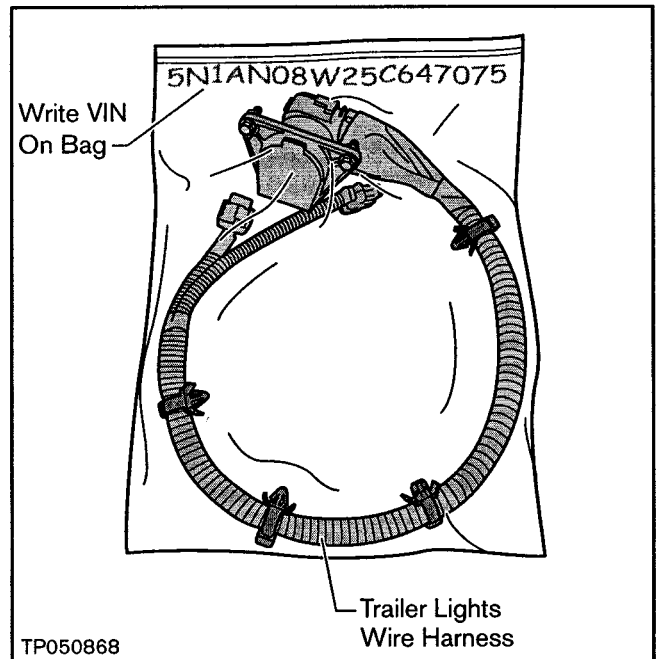

Figure 8

9. Remove three Bolts and disconnect the Rear Exhaust Pipe Hanger from the Frame (see Figure 9).

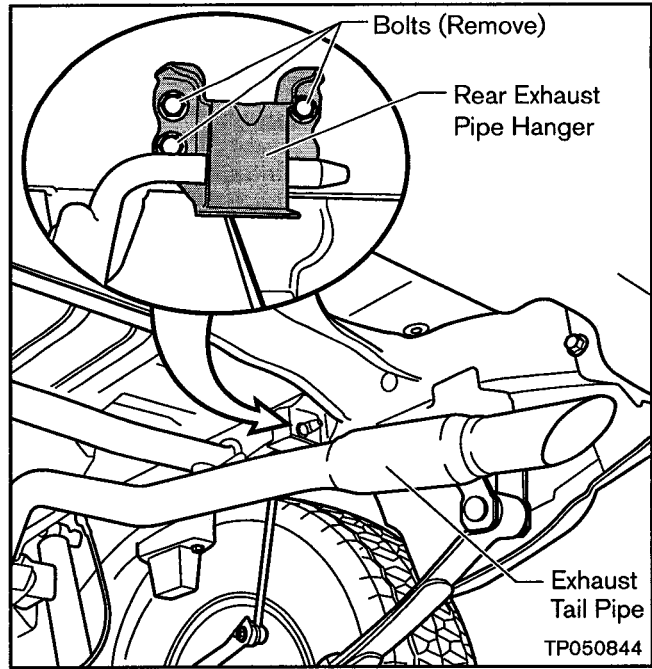

Figure 9

10. Remove the six Bolts that secure the Tow Hitch (see Figure 10).

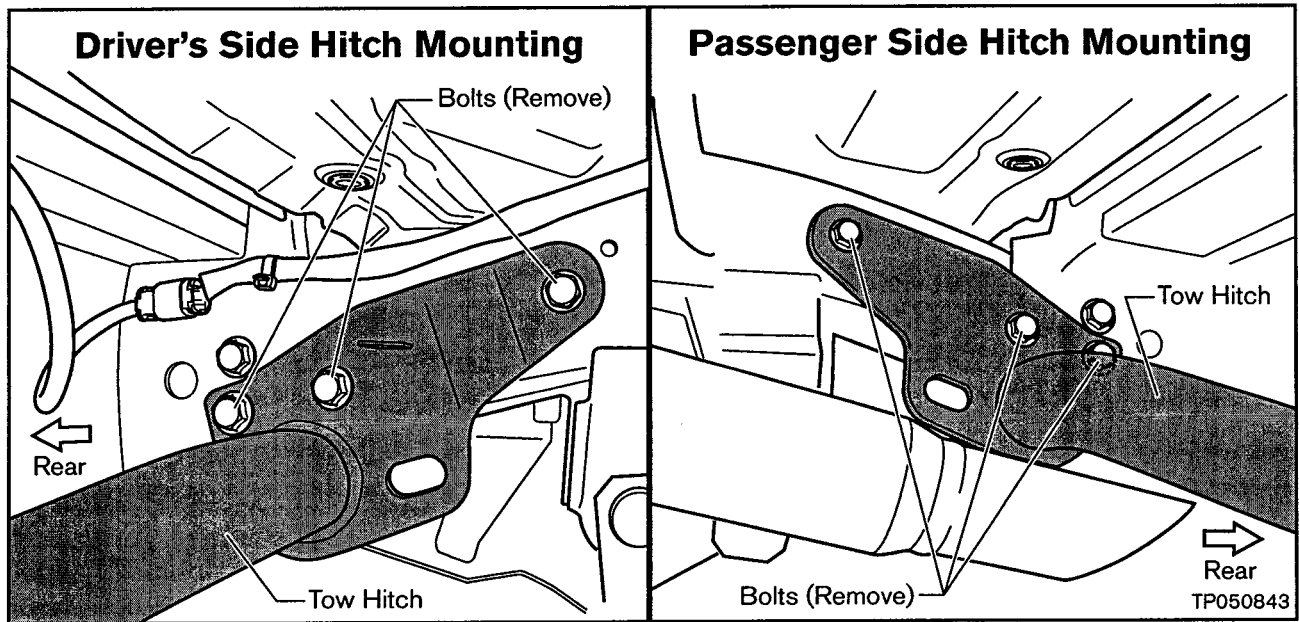

Figure 10

11. Remove the Tow Hitch from the vehicle (see Figure 11).

- When removing, lower the driver's side of the Tow Hitch first.

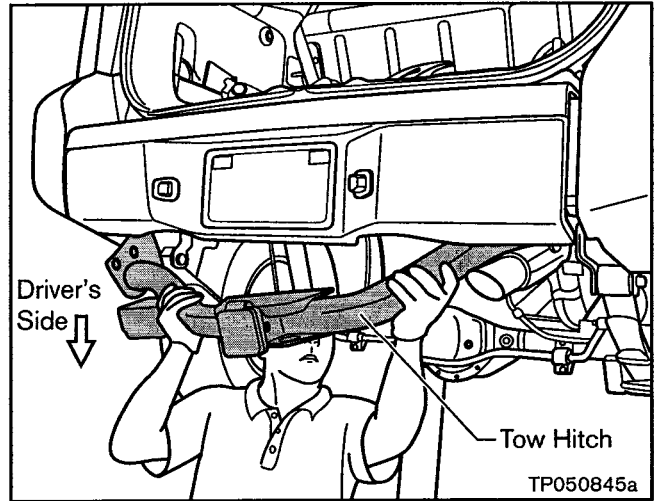

Figure 11

12. Re-install the original Tow Hitch Mounting Bolts into the vehicle frame and tighten the Bolts to **85 – 115 Nm (8.7 – 11.75 kg-m, 63 – 85 ft-lb)**.

CAUTION: You MUST re-install and tighten the original Tow Hitch Mounting Bolts into the vehicle frame. Four of the Bolts hold on the rear Bumper. Two of the Bolts plug up the unused threaded holes to protect from corrosion.

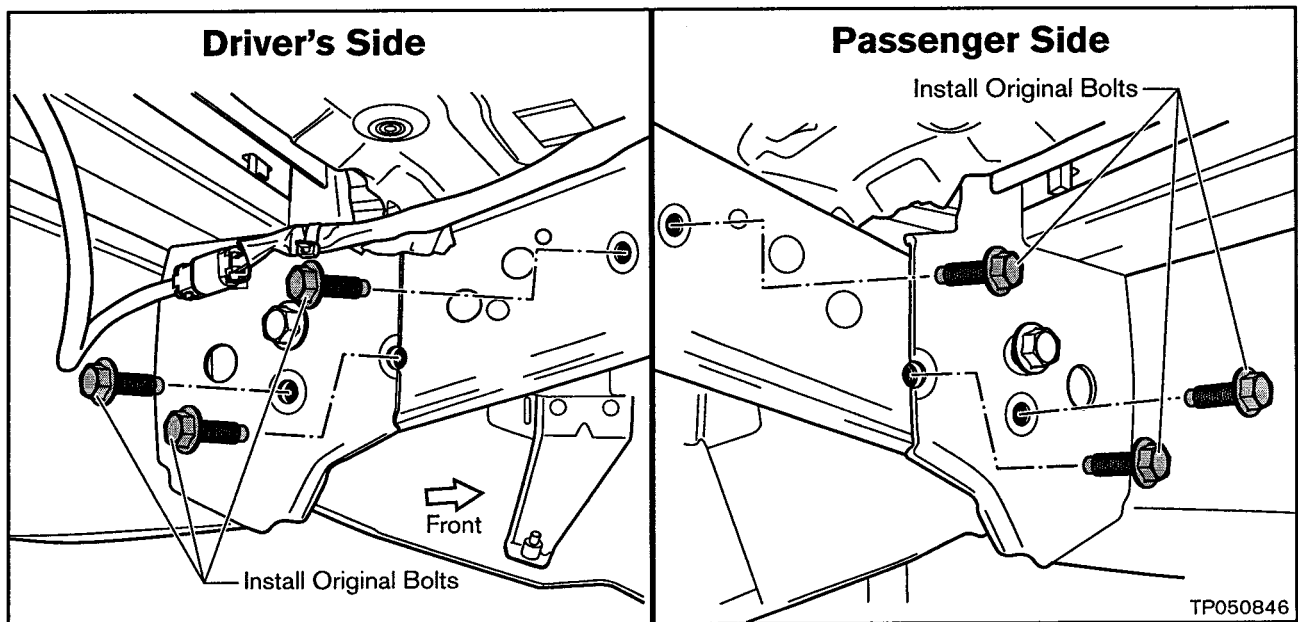

Figure 12

13. Re-install the Rear Exhaust Pipe Hanger and tighten the Bolts to **14 – 20 Nm (1.38 – 2.07 kg-m, 10 – 15 ft-lb)**.

14. Make sure the clearance at the Rear Exhaust Pipe Hanger is at least 4mm (see Figure 13).

- If it's less than 4mm, adjust Exhaust Tail Pipe as necessary for proper clearance.

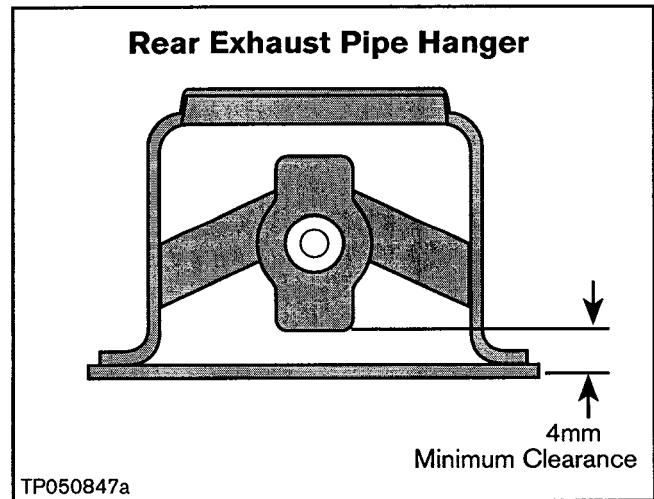

Figure 13

15. "Render" the original Tow Hitch useless (make it un-useable) as follows:

- Using a "cut off wheel" **and suitable hand and eye protection**, remove a section surrounding the Chain Mount Hole as shown in Figure 14. Then cut an "X" in the Tow Hitch surface (about 1/8" deep) as shown in Figure 14.
- Spray bright color paint (orange, red, or yellow) over the cut areas (see Figure 14).
- Discard the Tow Hitch.

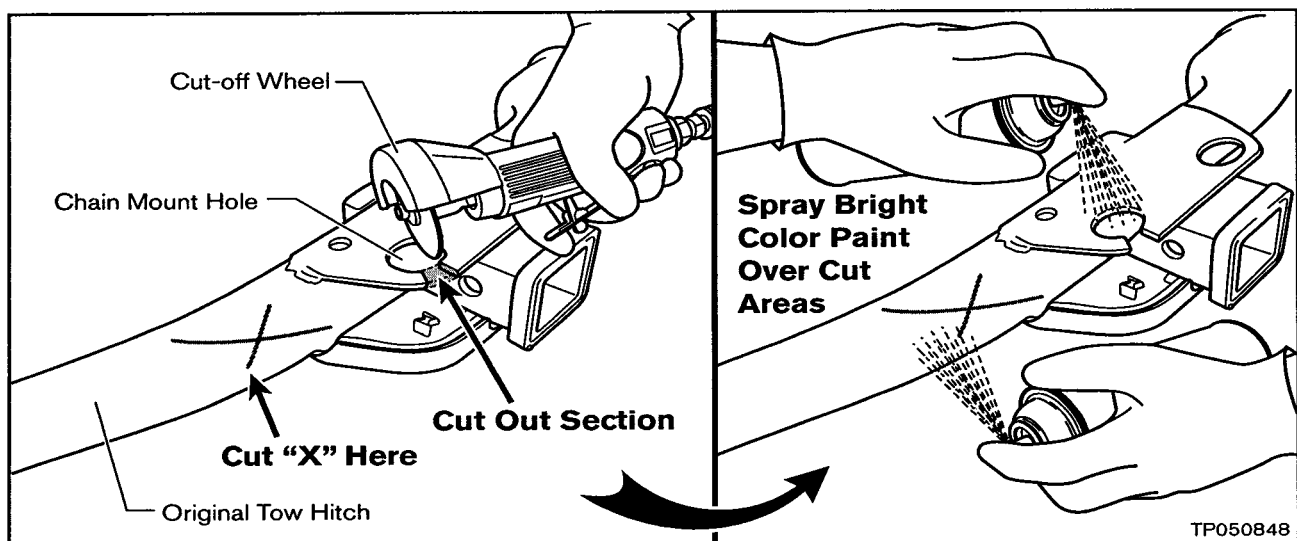

Figure 14

16. Re-install the Spare Tire/Wheel.

17. Store the Trailer Lights Wire Harness with the Tow Hitch Kit components for this vehicle (see Figure 15) in a safe location within the dealership (for example, Parts Department). These stored components will be re-installed when a replacement Tow Hitch is installed.

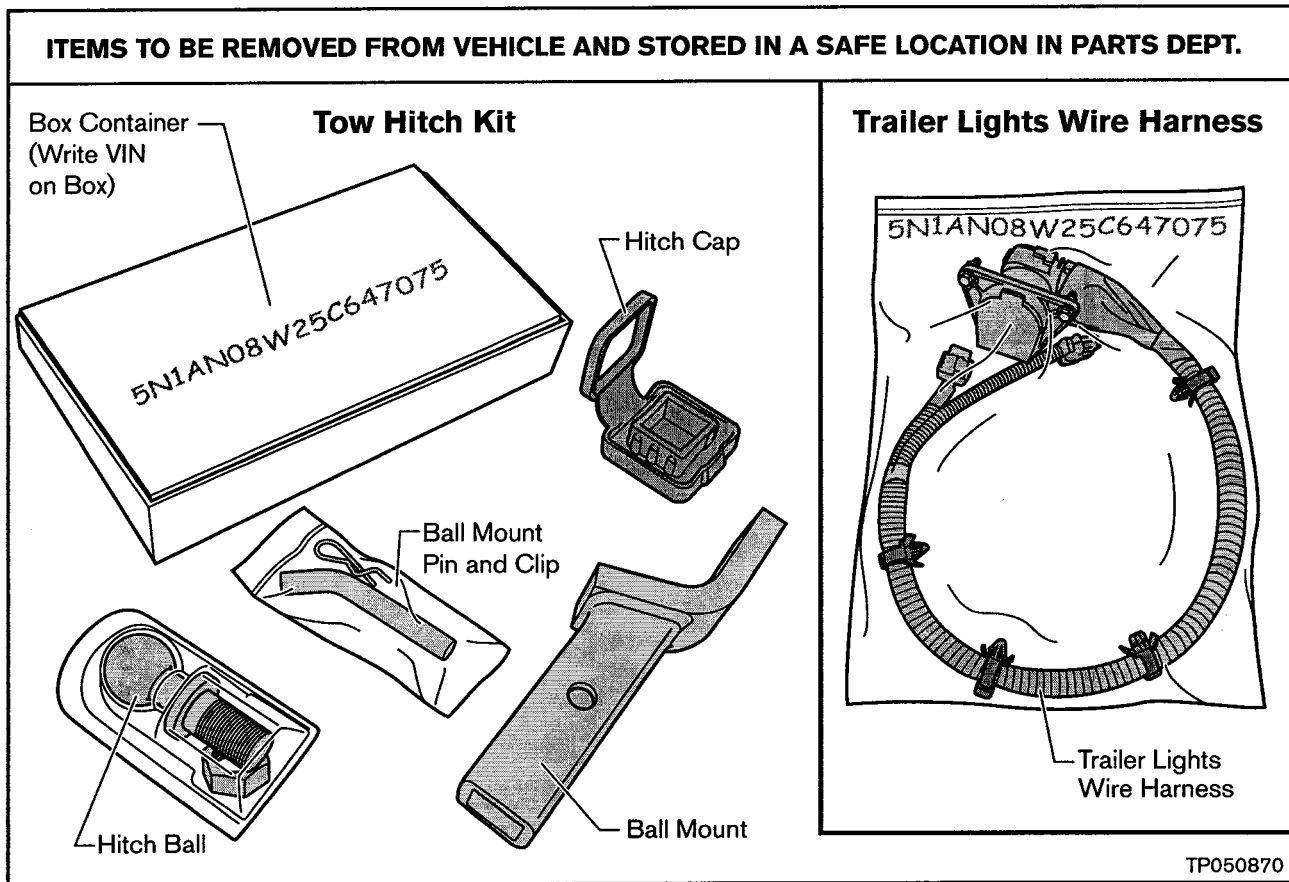

Figure 15

PARTS INFORMATION

- The Connector Plug Sets (P/N 999T8-LS000) are supplied directly by Nissan at no cost and are NOT available from your local PDC.
- Additional Connector Plug Sets can be obtained by sending an e-mail request to:

campaign.parts@nissan-usa.com

- Make sure you include the following information in your e-mail request:

To: campaign.parts@nissan-usa.com
From: _____
Subject: Additional Connector Plug Sets for 2005 Xterra Tow Hitch Removal
Dealer Name: _____
Dealer Number: _____
e-mail address: _____
or FAX Number: _____
Please ship _____ additional Connector Plug Sets.

NOTE: Please do not order more than needed or place duplicate orders. Part number 999T8-LS000 is coded as non-returnable.

CLAIMS INFORMATION

Submit a Campaign (CM) line claim using the following claims coding:

“CM” I.D.: PB006

DESCRIPTION	OP CODE	FRT
Remove Tow Hitch/Harness per Repair Instructions	PB0060	0.3 hrs

Expense Code:

EXPENSE CODE	DESCRIPTION	MAX AMOUNT
565	Parts Markup Allowance	\$2.41