



Mack Trucks, Inc.

Safety Recall ALERT

Date: 28 June 2005 **Number:** SRA-413-001
To: A343, C551, C631, C663, C696, D534, D865, P719
Attention: Service Manager, Warranty Manager, Parts Manager, Dealer Principal
From: Regulatory Compliance Department
Subject: Safety Recall SC0303, Pitman Arm Torque

Safety Recall Summary:

On **19** CV713 and **4** DM690S model chassis, the bolt that attaches the pitman arm to the steering gear may be under-torqued. The dealers who have sold vehicles subject to this recall are as follows:

Dealer #	Dealer Name	Model / Serial Number
A343	Potomac Mack	CV713 – 24240
C551	Transource Inc.	CV713 – 37172 CV713 – 37456 CV713 – 37457
C631	Hughes Motors	CV713 – 33644
C663	Shealy Mack	CV713 – 23705
C696	Mack Sales of B'Ham	CV713 – 38303 CV713 – 38304 CV713 – 38305 CV713 – 38306 CV713 – 37307 CV713 – 38308 CV713 – 38319
D534	Central Ind Mack	CV713 – 26944 CV713 – 26945 CV713 – 30688 CV713 – 30690 CV713 – 30691
D865	Mack Trucks Rochstr	DM690S – 30863 DM690S – 30864 DM690S – 30866 DM690S - 30868
P719	Seattle Mack	CV713 – 38940

IMPORTANT NOTE: Included with this alert is the list of vehicles along with current owners of vehicles that have been warranty registered. In some cases, we state that the “customer is not on file”. If this is the case, we ask the dealer to research their records and vehicle inventory.

Also, we are asking the Dealers to call the customers to make arrangements to have these vehicles corrected. The Dealer Instruction section below explains this and specifies the labor code

Dealer Instructions:

Since there is such a small population of vehicles involved, we ask that the dealer call the owner to schedule the repair of the vehicle(s). Mack Trucks will track the claims to see that all vehicles are corrected.

The labor code for the repair is **413 3E ZE 95** (includes 0.2 hr to check torque and 0.2 hr take charge time).

The bolt torque for the bolt that attaches the pitman arm to the steering gear is 610 Nm (450 ft-lb).

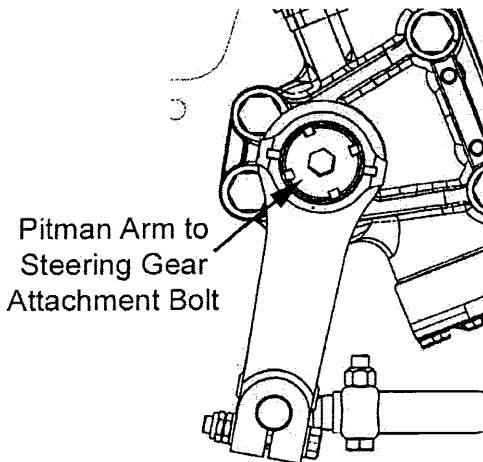

Dealer's Responsibility:

The National Traffic and Motor Vehicle Safety Act and Canadian Motor Vehicle Safety Act requires dealers to insure that all new and used vehicles are free of safety defects and comply with all relevant safety standards at the time of delivery to the consumer. All Safety Recalls, which affect new or used inventory, must be performed before the vehicle is sold or leased.

Additionally, Dealers should make their personnel aware of the safety recall. In the event that a dealer has a vehicle included in the safety recall, the vehicle must be addressed before releasing it to a customer.

Questions:

Contact the Regulatory Compliance Department at (336) 393-2233 if you have questions.

CV7 and DM6 Where Pitman Arm Torque May Be Insufficient

CHASSIS	CHASSIS VIN NUMBER	DLR CODE	Current Owner	Street	Town	State & Zip
CV713 - 23705	1M2AG11C36M023705	C663	SHEALY MACK DISTRIBUTORS	1340 BLUFF ROAD	COLUMBIA	SC 29201
CV713 - 24240	1M2AG11C16M024240	A343	HEIL CO.-FT.PAYNE, AL	106 45TH STREET N.E.	FORT PAYNE	AL 35967
CV713 - 26944	1M2AG11C36M026944	D534	JEFFERY AND TAMARA D AVIS	8682 WEST 600 SOUTH	RUSSIAVILLE	IN 46979
CV713 - 26945	1M2AG11C56M026945	D534	CENTRAL INDIANA MK S&S, I	1325 W THOMPSON RD.	INDIANAPOLIS	IN 46217
CV713 - 30688	1M2AG11C96M030688	D534	CENTRAL INDIANA MK S&S, I	1325 W THOMPSON RD.	INDIANAPOLIS	IN 46217
CV713 - 30690	1M2AG11C76M030690	D534	BAUMGARTNER COMPANY ASPHA	8805 725 WEST	TIPTON	IN 46072
CV713 - 30691	1M2AG11C96M030691	D534	BAUMGARTNER COMPANY ASPHA	8805 725 WEST	TIPTON	IN 46072
CV713 - 33644	1M2AG11C46M033644	C631	NICHOLS NURSERY INC	2742 PULASKI HWY	NEWARK	DE 19702
CV713 - 37172	1M2AG11C96M037172	C551	HILCO TRANSPORT	7700 KENMONT DRIVE	GREENSBORO	NC 27425
CV713 - 37456	1M2AG11C16M037456	C551	HILCO TRANSPORT	7700 KENMONT DRIVE	GREENSBORO	NC 27425
CV713 - 37457	1M2AG11C36M037457	C551	HILCO TRANSPORT	7700 KENMONT DRIVE	GREENSBORO	NC 27425
CV713 - 38303	1M2AG11C36M038303	C696	CONECUH COUNTY COMMISSION	424A RURAL STREET	EVERGREEN	AL 36401
CV713 - 38304	1M2AG11C56M038304	C696	CONECUH COUNTY COMMISSION	434A RURAL STREET	EVERGREEN	AL 36401
CV713 - 38305	1M2AG11C76M038305	C696	CONECUH COUNTY COMMISSION	434A RURAL STREET	EVERGREEN	AL 36401
CV713 - 38306	1M2AG11C96M038306	C696	CONECUH COUNTY COMMISSION	434A RURAL STREET	EVERGREEN	AL 36401
CV713 - 38307	1M2AG11C06M038307	C696	CONECUH COUNTY COMMISSION	434A RURAL STREET	EVERGREEN	AL 36401
CV713 - 38308	1M2AG11C26M038308	C696	CONECUH COUNTY COMMISSION	434A RURAL STREET	EVERGREEN	AL 36401
CV713 - 38319	1M2AG11C76M038319	C696	DALLAS COUNTY COMMISSION	200 PLANT STREET	SELMA	AL 36702
CV713 - 38940	1M2AG10C96M038940	P719	COLUMBIA BODY MANUFACTURI	10037 SE MATHER ROAD	CLACKAMAS	OR 97015
DM690S - 30863	1M2B209CX6M030863	D865	MCNEILUS COMPANIES	CO RD 34 EAST	DODGE CENTER	MN 55927
DM690S - 30864	1M2B209C16M030864	D865	MACK TRUCKS ROCHESTER	P.O. BOX 6699	ROCHESTER	MN 55903
DM690S - 30866	1M2B209C56M030866	D865	MCNEILUS COMPANIES	CO RD 34 EAST	DODGE CENTER	MN 55927
DM690S - 30868	1M2B209C96M030868	D865	MCNEILUS COMPANIES	CO RD 34 EAST	DODGE CENTER	MN 55927