



Mack Trucks, Inc.

Service ALERT

Date: 24 March 2005 **Number:** SA-224-002
To: All U.S. & Canadian Distributors
Attention: Service Manager, Warranty Manager, Parts Manager
From: Mack Reliability Engineering Department
Subject: Hold On Performing SC-292 Fuel Supply Hose Safety Campaign

Important Notice

URGENT: Stop performing the SC-292 Fuel Supply Hose Safety Campaign until further notice.

Mack Reliability Engineering is instituting this hold on this Campaign due to numerous complaints from the field. The complaint is that after installing the 42QE3240P14 fuel supply hose, fuel leakage occurs at the connection between the fuel supply hose and fuel supply pump outlet fitting.

The swage on the elbow end of the fitting for the fuel supply hose (42QE3240P14) is in question and needs to be reviewed by the supplier. Reliability Engineering will notify dealers regarding when the temporary hold on this Campaign ends and the specific actions to take before again performing this Campaign.

05V-015



VEHICLE RECALL

SC292

(Not applicable to Mack Trucks Australia)

Date: 3/8/05 (Supersedes SC292 dated 2/14/05)

To: All MACK Dealers

Subject: Fuel Supply Line Replacement — ASET™ AC Engines

Information:

It has been determined that on certain CX, CH, CXN and CHN model vehicles equipped with ASET™ AC engines, the fuel supply line that connects from the fuel supply pump to the cylinder block fuel gallery inlet fitting (routed behind the EGR cooler) may be subject to overheating and/or abrasion which could potentially lead to premature hose failure. Approximately 15,700 CX, CH, CXN and CHN model chassis equipped with ASET™ AC engines manufactured March 2001 through December 2004 (within engine serial No. range 1D3536–4Y2035) are involved in this campaign. A list of affected vehicles has been sent to all applicable dealers.

Procedures:

NOTE

Before proceeding, check the recall status in the MACKnet system to see if the recall has already been completed. Recall status can also be checked by looking at the Campaign Completion Label located on the lower edge of the passenger-side door. If the recall has been completed, the recall number (SC292) and the completion date should be written on the label.

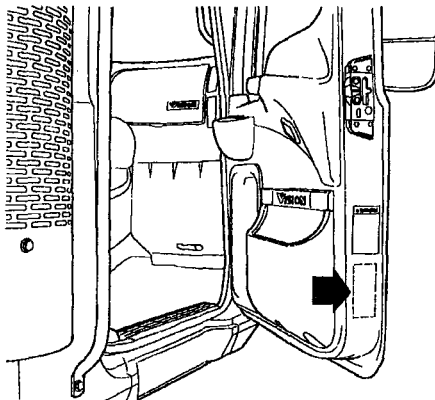

703153a

Figure 1 — Campaign Label Location

The fuel supply line on all affected vehicles must be replaced.

Before proceeding, check the existing fuel supply line to make sure the line has not already been replaced. The current fuel supply line can be identified by the relatively smooth end crimps (as opposed to the original and interim production hoses), and the absence of the convoluted tubing around the hose. Additionally, the end fitting on the end of the line connected to the supply pump may have a yellow paint mark to identify it as the current line. If the existing fuel supply line looks the same as the original or interim production lines shown in the illustration below, they must be replaced with the current production supply line.

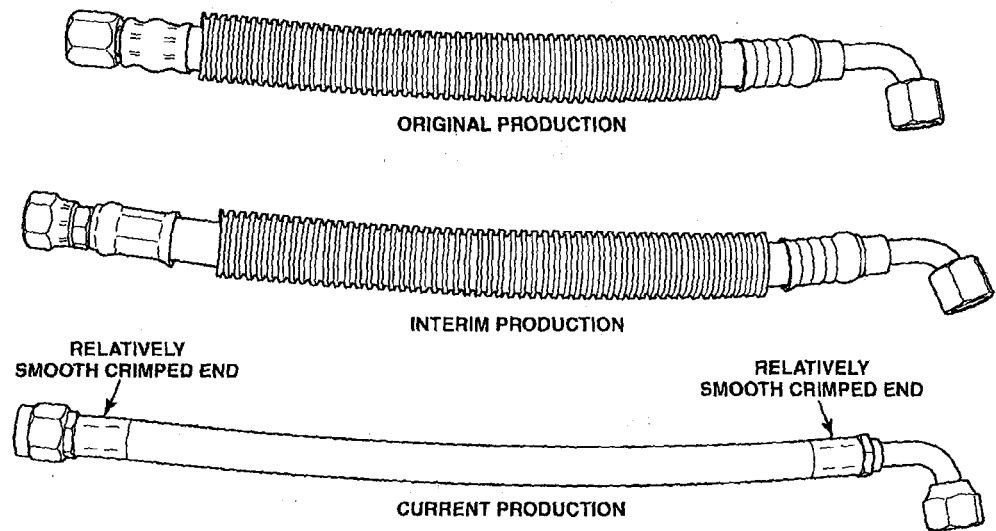

269889a

Figure 2 — Identifying Current Fuel Supply Line

Fuel supply line replacement procedures are as follows:

NOTE

Two variations of fuel supply pumps are used on ASET™ AC engines, either with or without provisions for a pump-mounted secondary fuel filter. Fuel supply line replacement procedures are different for the two variations of pumps. Figure 3 illustrates the differences between the two fuel supply pumps.

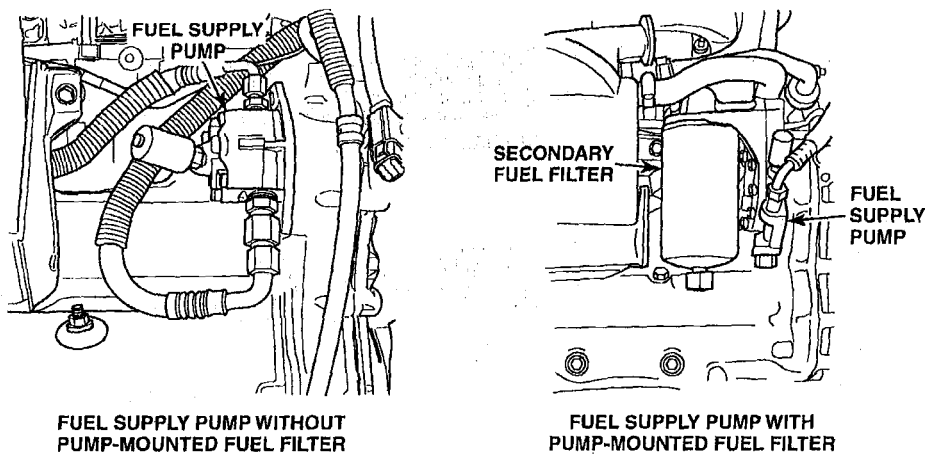

269844a

Figure 3 — Fuel Supply Pumps with and without Pump-Mounted Fuel Filter

Fuel Supply Line Replacement Procedures — Supply Pumps without Pump-Mounted Secondary Fuel Filter

1. Secure the chassis for service, apply the parking brakes and block the wheels to prevent the vehicle from moving.
2. Open the hood.
3. Drain the coolant into a clean container, and then cover the container and set it aside. The same coolant will be used to refill the cooling system when the fuel line replacement procedures have been completed.

4. Remove the EGR cooler.

NOTE

For complete EGR cooler removal procedures, refer to the *ASET™ AC Diesel Engine Service Manual*, 5-110.

5. Remove the clamp that secures the two fuel supply lines to the cylinder block just to the rear of the supply pump. Discard the clamp and bolt as they will not be reused.
6. Remove the fuel supply line that runs between the fuel supply pump and the fuel inlet fitting.
7. Remove the unit pump front heat shield, and then disconnect the harness connector from the fuel temperature sensor.
8. Loosen the fuel inlet fitting jam nut and then orient the fitting as follows:

NOTE

Proper orientation of the fuel inlet fitting is essential.

- a. Rotate the fitting so that the fuel temperature sensor is pointed toward the front of the engine at an angle of approximately 45 degrees upward.
- b. Hand-tighten the fitting jam nut.
- c. Place the fitting positioning tool (tool No. TS901) on top of the nameplates for the Nos. 2 and 3 unit pumps and place the 45-degree angled surface of the tool against the flat surface of the fuel inlet fitting as shown in the following illustration.

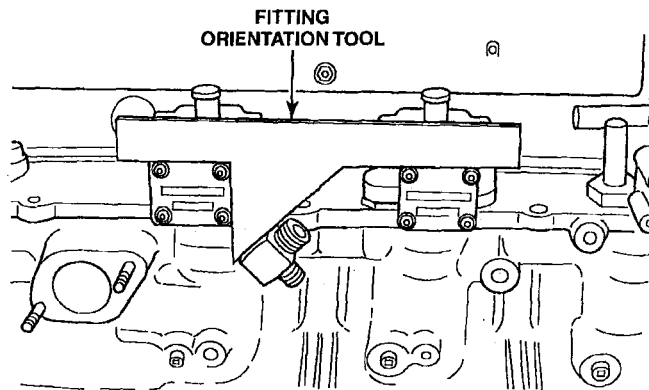

269853a

Figure 4 — Fuel Fitting Orientation Tool

NOTE

The fuel fitting orientation tool (tool No. TS901) has been sent to all MACK dealers.

- d. With the fuel fitting in the proper position (as shown in figure 4), use a 19 mm crow's foot wrench to tighten the fitting jam nut to 35 lb-ft (48 N•m).
 - e. Use the tool to recheck the fitting orientation, and then reposition and retorque the jam nut as required.
9. Install the new fuel supply line (part No. 42QE3240P14) as follows:
- a. Connect the 90-degree end fitting to the fuel supply pump.
 - b. With the 90-degree fitting pointing toward the cylinder block while maintaining 1/2" (12.7 mm) clearance between the line and the block, hand tighten the end fitting at the supply pump.
 - c. Connect the straight-end fitting to the fuel inlet fitting.
 - d. With the straight-end fitting hand-tightened only, push the fuel line toward the cylinder block.
 - e. Tighten the fuel line straight-end fitting by holding the connecting nut with a 19 mm wrench and the adjacent line nut with a 14 mm wrench. To keep the fuel line properly positioned when the line nut is tightened, it will be necessary to exert downward (counterclockwise) pressure on the 14 mm wrench while the line end-nut is tightened with the 19 mm wrench.

NOTE

The 14 mm wrench must be used to keep the fuel line from twisting away from the cylinder block and thus being too close to the EGR cooler.

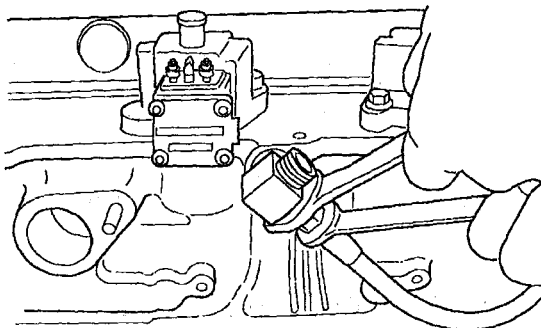

269852a

Figure 5 — Tightening Fuel Line Fitting Connecting Nut

- f. Push the 90-degree end fitting toward the cylinder block as much as possible while maintaining 1/4" to 1/2" (6.35 to 12.7 mm) of clearance between the line and the cylinder block at all locations along the line.
- g. With the fuel line properly routed, tighten the line nut at the supply pump fitting.
- h. Again, check the fuel line to ensure that the line is routed as close to the cylinder block as possible, maintaining a minimum of 1/4" clearance at all locations. Also, use the fitting positioning tool (part No. TS901) to recheck fitting orientation after tightening the line end fittings.

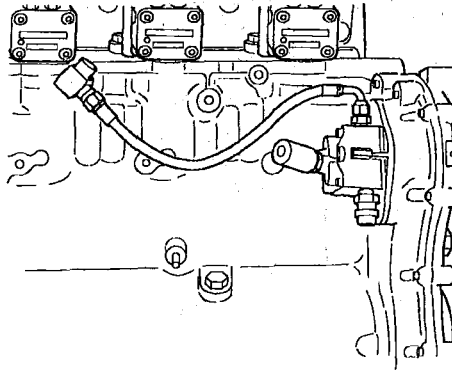

269851a

Figure 6 — Fuel Supply Line Properly Installed

10. Reconnect the harness connector to the fuel temperature sensor, and then reinstall the unit pump front heat shield.
11. Set the EGR cooler into place on the mounting studs, and then check that there is a minimum of 1/4" (6.35 mm) of clearance between the front inboard area of the cooler mounting bracket and the fuel line, and also between the line and the cooler mounting bracket inboard location as shown in the following illustration.

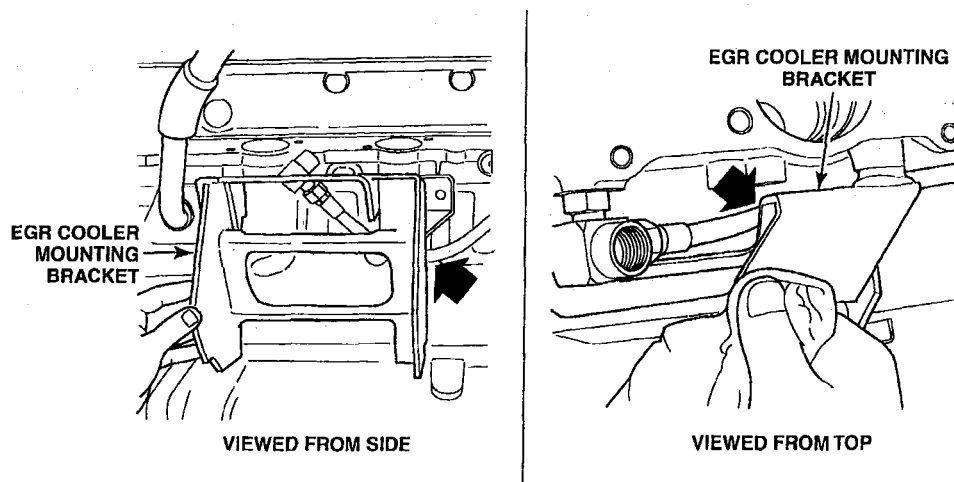

269850a

Figure 7 — Proper Clearance Between Fuel Supply Line and EGR Cooler Mounting Bracket (Cutaway EGR Cooler Mounting Bracket Used for Illustration Clarity)

After verifying proper clearance, reinstall the EGR cooler. When installing the cooler, use a new gasket (part No. 449GC236M) at the hot tube flange, and use a new T-bolt (part No. 2529-4A920082) and nut (part No. 2529-4A920030) for the hot tube flange clamp. If the existing clamp does not have a replaceable T-bolt, use a new clamp (part No. 260GB215).

12. Note the routing of the fuel supply pump inlet line (at the bottom of the supply pump). Route the inlet line as shown in the following illustration.

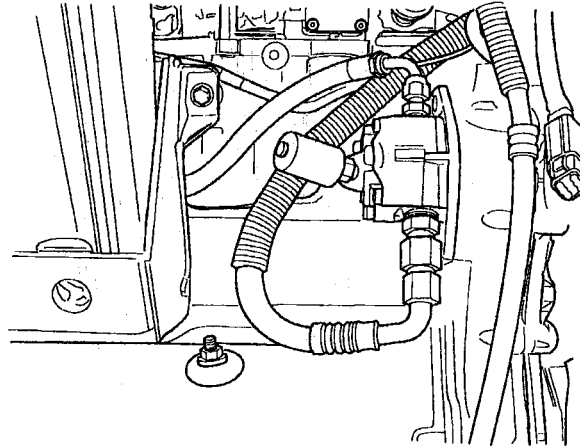

269949a

Figure 8 — Fuel Inlet Line Routing to Supply Pump

With the new line from the supply pump to the fuel gallery inlet fitting, the clamp that had originally been used to secure the supply pump inlet and outlet lines to the cylinder block is no longer used. Although the supply pump inlet line routing remains unchanged, make sure that it is routed and connected to the supply pump fitting as shown in figure 8 above. Note that the 90-degree fitting at the supply pump inlet port is pointing slightly inboard toward the dipstick boss plug. If the existing length of protective conduit is not long enough to cover the entire length of line from the cooling plate to within 4" (102 mm) of the end fitting at the supply pump, slide the entire length of conduit downward so that the lower end of the line is covered as shown in figure 8.

13. Refill the cooling system with the same coolant originally drained from the system.
14. Start the engine and check for fuel and coolant leaks.
15. Stop the engine and recheck the coolant level. Replenish with coolant and repeat steps 14 and 15 as required until the cooling system has been thoroughly de-aerated.
16. Using a yellow paint stick, mark the end fitting on the end of the supply line connected to the fuel supply pump to identify that the line has been replaced.

Fuel Supply Line Replacement Procedures — Fuel Supply Pump with Pump-Mounted Secondary Fuel Filter

1. Secure the chassis for service, apply the parking brakes and block the wheels to prevent the vehicle from moving.
2. Open the hood.
3. Drain the coolant into a clean container, and then cover the container and set it aside. The same coolant will be used to refill the cooling system when the fuel line replacement procedures have been completed.
4. Remove the secondary fuel filter from the supply pump, and dispose of the filter in an environmentally safe manner.
5. Remove the EGR cooler.

NOTE

For complete EGR cooler removal procedures, refer to the *ASET™ AC Diesel Engine Service Manual*, 5-110.

6. Remove the fuel supply line that runs between the fuel supply pump and the fuel inlet fitting.
7. Remove the unit pump front heat shield, and then disconnect the harness connector from the fuel temperature sensor.
8. Loosen the fuel inlet fitting jam nut and then orient the fitting as follows:

NOTE

Proper orientation of the fuel inlet fitting is essential.

- a. Rotate the fitting so that the fuel temperature sensor is pointed toward the front of the engine at an angle of approximately 45-degrees upward.
- b. Hand-tighten the fitting jam nut.
- c. Place the fitting positioning tool (tool No. TS901) on top of the nameplates for the Nos. 2 and 3 unit pumps and place the 45 degree angled surface of the tool against the flat surface of the fuel inlet fitting as shown in the following illustration.

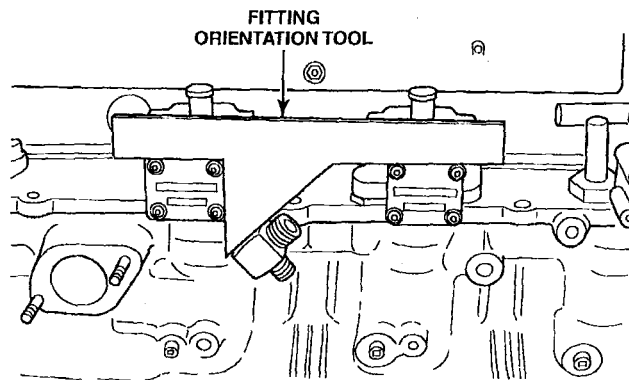

269853a

Figure 9 — Fuel Fitting Orientation Tool

NOTE

The fuel fitting orientation tool (tool No. TS901) has been sent to all MACK dealers.

- d. With the fuel fitting in the proper position (as shown in figure 9), use a 19 mm crows foot wrench to tighten the fitting jam nut to 35 lb-ft (48 N•m).
 - e. Use the tool to recheck the fitting orientation, and then reposition and retorque the jam nut as required.
9. Install the new fuel supply line (part No. 42QE3240P14) as follows:
- a. Connect the 90-degree end fitting to the fuel supply pump outlet fitting and hand-tighten.
 - b. Position the fitting so that the line is pointing directly toward the EGR valve oil supply fitting (or the pipe plug at this location if the location is not used for the EGR valve oil supply).
 - c. After verifying that the line is properly positioned (refer to the following illustration), use a 19 mm wrench to tighten the line end fitting at the supply pump.

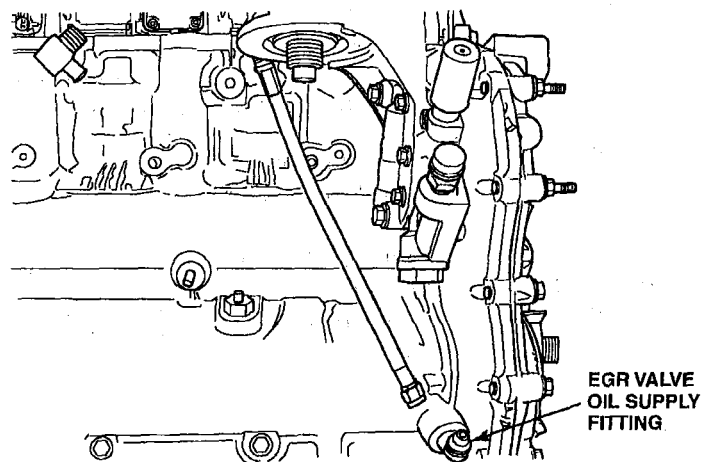

269848a

Figure 10 — Proper Line Orientation at Fuel Supply Pump Outlet Fitting

REV

- d. Observe the 90-degree fitting orientation from above and verify that there is a minimum of 0.060" to 0.080" (1.524 to 2.032 mm) clearance between the steel 90-degree section of the line and the cylinder block (refer to the following illustration) and verify that the end fitting has been properly tightened.

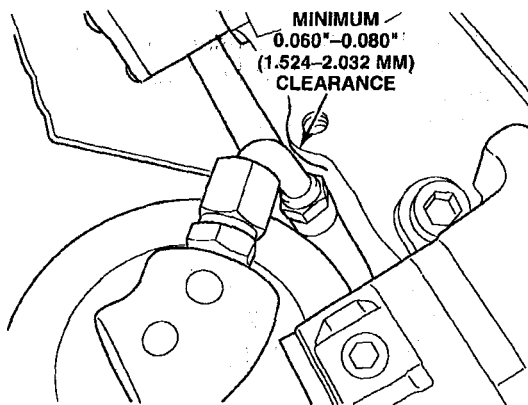

269847a

Figure 11 — Proper Fitting Orientation

- e. Connect and hand-tighten the straight-end fitting to the fuel gallery inlet fitting.
- f. With the fitting hand-tightened only, push the line inward toward the cylinder block.

- g. Tighten the fuel line straight-end fitting by holding the connecting nut with a 19 mm wrench and the adjacent line nut with a 14 mm wrench. To keep the fuel line properly positioned when the line nut is tightened, it will be necessary to exert downward (counterclockwise) pressure on the 14 mm wrench while the line end-nut is tightened with the 19 mm wrench.

NOTE

The 14 mm wrench must be used to keep the fuel line from twisting away from the cylinder block and thus being too close to the EGR cooler.

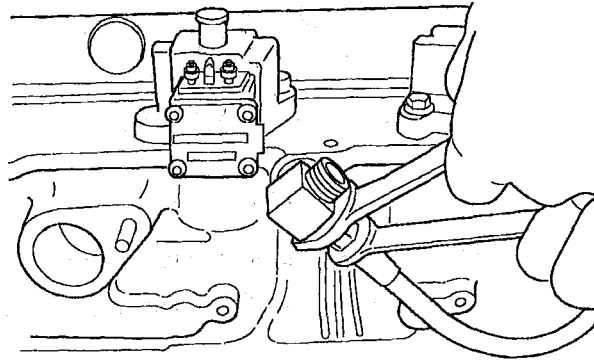

269B52a

Figure 12 — Tightening Fuel Line Fitting Connecting Nut

After tightening the line, use the fitting positioning tool (part No. TS901) to recheck the fitting orientation.

- h. After tightening the line nut, check that there is approximately 1/2" (12.7 mm) of clearance between the line and the cylinder block at the location shown in the following illustration.

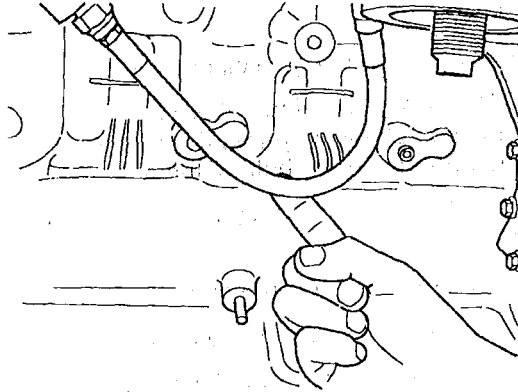

269846a

Figure 13 — Checking Clearance Between Fuel Supply Line and Cylinder Block

If clearance at the above location is greater than 5/8" (15.88 mm), the line will be too close to the EGR cooler. If this is the case, the line must be repositioned.

10. Reconnect the harness connector to the fuel temperature sensor, and then reinstall the unit pump front heat shield.
11. Set the EGR cooler into place on the mounting studs, and then check that there is a minimum of 1/4" (6.35 mm) of clearance between the front inboard area of the cooler mounting bracket and the fuel line as shown in the following illustration. If the 90-degree fitting was properly positioned, the 1/4" (6.35 mm) clearance at this location should be obtainable. Observe the visible section of the fuel supply line to ensure that there is good clearance between the cylinder block and the EGR cooler.

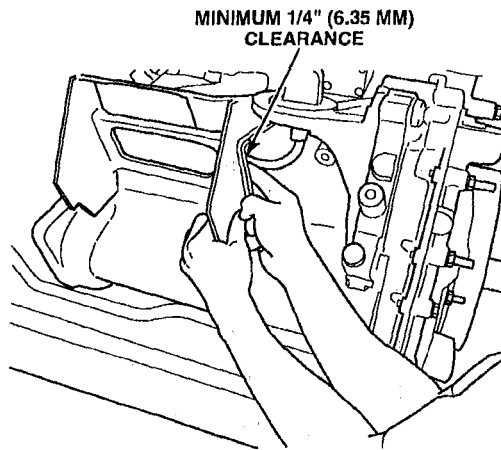

269845a

**Figure 14 — Proper Clearance Between Fuel Supply Line and EGR Cooler Mounting Bracket
(Cutaway EGR Cooler Bracket Used in Illustration for Clarity)**

After verifying proper clearance, reinstall the EGR cooler. When installing the cooler, use a new gasket (part No. 449GC236M) at the hot tube flange, and use a new T-bolt (part No. 2529-4A920082) and nut (part No. 2529-4A920030) for the hot tube flange clamp. If the existing clamp does not have a replaceable T-bolt, use a new clamp (part No. 260GB215).

12. Install a new secondary fuel filter (part Nos. 483GB476M without drain or 483GB477M with drain) as follows:
 - a. Apply a thin film of clean engine oil to the sealing gasket of the new filter.
 - b. Prime the filter by pouring clean filtered fuel through the series of small holes at the top of the filter. DO NOT prime the filter through the center hole. Use care to avoid dirt entering the center hole of the filter.
 - c. Install the new filter and tighten an additional 3/4 to 1 turn by hand after the gasket contacts the base.
13. Refill the cooling system with the same coolant originally drained from the system.
14. Start the engine and check for fuel and coolant leaks.
15. Stop the engine and recheck the coolant level. Replenish with coolant and repeat steps 13 and 14 as required until the cooling system has been thoroughly de-aerated.
16. Using a yellow paint stick, mark the end fitting on the end of the supply line connected to the fuel supply pump to identify that the line has been replaced.

NOTE

To indicate that the recall has been completed, use a permanent-type marker (such as a Sharpie®) to write the campaign number (SC292) and completion date in the spaces provided on the Campaign Completion label located on the lower edge (below the door latch) of the passenger-side door. If a label is not already affixed to the door, apply a label (part No. TS897) and supply the information as required. Campaign Completion labels are available in packs of 50 and can be ordered by faxing a completed BR313 to Pacesetters Business Services at 610-264-9465.

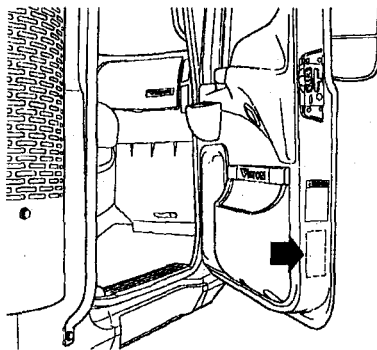

703153a

Figure 15 — Campaign Label Location

PARTS REQUIRED:

Order vehicle recall parts on a separate stock order and process through the parts distribution center normally serving your area. Do not include parts on this requisition that are not required for this recall campaign.

International orders are to be prefixed — V.O.R.

Required Part Numbers:

Qty.	Part No.	Description
1	42QE3240P14	Fuel supply line (stainless steel braided line with an integral polymer-fiber [Technora®] cover over the steel braid)
1	449GC236M	Gasket, EGR cooler hot tube flange
1*	2529-4A920082	T-bolt, EGR hot tube clamp
1*	2529-4A920030	Nut, EGR hot tube clamp
1	483GB476M	Fuel filter without drain, secondary, for engines equipped with fuel supply pump-mounted secondary filter
	483GB477M	Fuel filter with drain, secondary, for engines equipped with fuel supply pump-mounted secondary filter

* Use hot tube clamp part No. 260GB215 if the existing clamp does not have a replaceable T-bolt.

REMOVED PARTS:

The removed fuel line and associated parts may be scrapped locally.

REIMBURSEMENT:

Campaign expenses are to be recovered through normal warranty claim procedures. Enter the following information on the warranty claim:

UNDER

ENTER

Failed Part No.....

SC0292

Labor Code/Allowance

231 6C 23 95 — 0.2 hr.

Time allowed to take charge of vehicle and check MACKnet system and campaign completion label to determine campaign status.

231 6B 23 95 — 1.9 hr.

Time allowed to replace fuel supply line on CX, CH, CXN and CHN model chassis equipped with ASET™ AC engines. Does not include "take-charge" time.

NOTE

As required by Federal Motor Vehicle Safety Standards 49 CFR 573.11, no vehicle subject to an open safety campaign shall be delivered to the customer until such time as the defect or noncompliance is remedied.