

PART 573 Defect and Non-Compliance Report

On 19, April 2005, Webasto decided that a defect which relates to motor vehicle safety exists in the motor vehicles listed below, and is furnishing notification to the National Highway Traffic Safety Administration in accordance with 49 CFR Part 573, Defects and Non-Compliance Reports.

This report was prepared on April 19, 2005

Manufacturer's Identificaiton Code for this Recall: SAF 05004

1. Fabricating Manufacturer/Brand Name/Trademark Owner of the Recalled Vehicle

Optima Bus.Corp.
P.O. Box 19140
Wichita, KS 67204-9140

For further information on this report contact:
Keith Pfannenstiel, P.E.
Director of Engineering
P.O. Box 19140
Wichita, KS 67204-9140

Phone: 316-779-7700
Fax: 316-779-7712

The person preparing this report is:
Andrew Schaar
Technical Publications
P.O. Box 19140
Wichita, Ks 67204-9140

Signed: _____

Andrew Schaar

05V-167
(8 pages)

RECEIVED
2005 APR 25 10:25
OFFICE OF THE DIRECTOR
NHTSA

2. Identification of vehicles(s) with potential defect

Make: Optima Bus Corp.
Model Years Involved: -2002-2005
Model: Opus 29 & 34
Production Dates: Beginning:-11-01 2002 Ending: -2-12-2005
VIN Range: Beginning: 29 - 535176 Ending: 216270 , 34 - Beginning: 535025 Ending: 216131
Vehicle Type: Diesel
Bodystyle: Opus

Description of Vehicles in Recall Compared to those Not in the Recall: Units may have a hydraulic hose rubbing on top of the air governor causing the hydraulic line to be rubbed through.

Approximate Percentage of the Production of all the Recalled Models: 100%

3. Total Number of Vehicles Recalled Potentially Containing the Defect: 201

Total Number Potentially Affected by the Recall: 201

PART 573 Defect and Non-Compliance Report

4. **Approximate Percentage of the Total Number of Vehicles Estimated to Actually Contain the Defect:** 100%

Determination of Recall Population: 100%

5. **Defect Description:** Power steering pump hydraulic line.

Cause of Defect: Power steering pump hydraulic line can rub on top of the air governor causing the hydraulic line to be rubbed through resulting in a leak and loss of hydraulic fluid, this fluid could ignite if it comes in contact with a hot source.

Consequences of Defect: Hydraulic line may be rubbed through resulting in a leak and loss of hydraulic fluid.

Warning Which Can Occur: Hydraulic line may be rubbed through resulting in a leak and loss of hydraulic fluid, this fluid could ignite if it comes in contact with a hot source.

Corporate Name and Address of the Supplier of Defective Component: Optima Bus Corp. 1601 E 77th. North Valley Center, Kansas 67147

Name and Title of CEO or Representative of Supplier: Keith Pfannenstiel, Director of Engineering

6. **Chronological Summary (Defect)**

7. **Test Reports/Data that Non-Compliance was determined:** Not Applicable

8. **Manufacturer's Remedy for the Defect -** Install a bracket and clamp on the air governor bracket that holds and secures the hose away from the air governor eliminating the possibility of chaffing.

Distinguishing Characteristics of the Remedy Component/Assembly Versus the Recalled Component/Assembly: The hydraulic hose will no longer rub on top of the air governor.

9. **How and When the Recall Condition was Corrected in Production -** April 2005, Installed a bracket and clamp on the air governor bracket that holds and secures the hose away from the air governor eliminating the possibility of chaffing.

10. **Recall Schedule -** All Optima Bus Corp. customers will be notified of the recall and required to inspect and repair their vehicle. Optima will send the modification kit with instructions to the customer.



Safety Bulletin

DATE: 19 February, 2003

TO: All Opus under 30' & 34' operators with Cummins ISB02 engines.

MODEL(s): Under 30' & 34' with Cummins ISB02 engines.

SUBJECT: Hydraulic Line Routing

Dear Opus Customer:

This notice is sent to you in accordance with the requirements of the National Traffic and Motor Vehicle Safety Act.

Optima Bus has determined that a defect which relates to motor vehicle safety exists in the power steering pump hydraulic line routing.

There is a possibility that the hydraulic line coming off of the power steering pump is rubbing on top of the air governor. This rubbing may cause the hydraulic line to be rubbed through resulting in a leak and a loss of hydraulic fluid, this fluid could ignite if it comes in contact with a hot source.

This Safety Recall corrects this problem by installing a bracket and clamp (Mod. Kit 30-0012-001, P/N 24367312) that will lift and secure the lines away from the air governor eliminating the possibility of chaffing.

Perform the steps provided in **Instructions**, complete the certificate of compliance, and return the certificate of compliance to Optima Bus Corp. at your earliest convenience.



Safety Bulletin

Overview:

This modification kit provides a bracket and clamp that will lift and secure the lines away from the air governor eliminating the possibility of chaffing a hydraulic line.

Instructions:

Parts Provided in this Kit:

- 1 - HHCS, 5/16 - 18 X 1 P/N 60749400
- 2 - HHCS, 5/16 - 18 X 3 1/4 P/N 60751200
- 2 - Washer, 5/16, P/N 68530600
- 3 - Hex Nut, 5/16 - 18 P/N 64808300
- 1 - Hose, P/N 30-3017B-003
- 1 - Bracket, P/N 30-9533-002
- 1 - P-Clamp, P/N 21622500

Installation Instructions:

1. Set the parking brake on the coach.
2. Place the MASTER RUN SWITCH and the MASTER BATTERY SWITCH in the OFF position.
3. Remove the crb side rear seat to use the curb side engine access door. (Figure 1)
 - a. Locate and remove the bolts, washers, and lock washers securing the single middle seat to the outer seats. When the attaching hardware is removed pull the seat forward; not up, to remove.
 - b. Remove all of the attaching hardware mounting the outer seat to the rear deck and pull these seat forward; not up, to remove.

Safety Bulletin

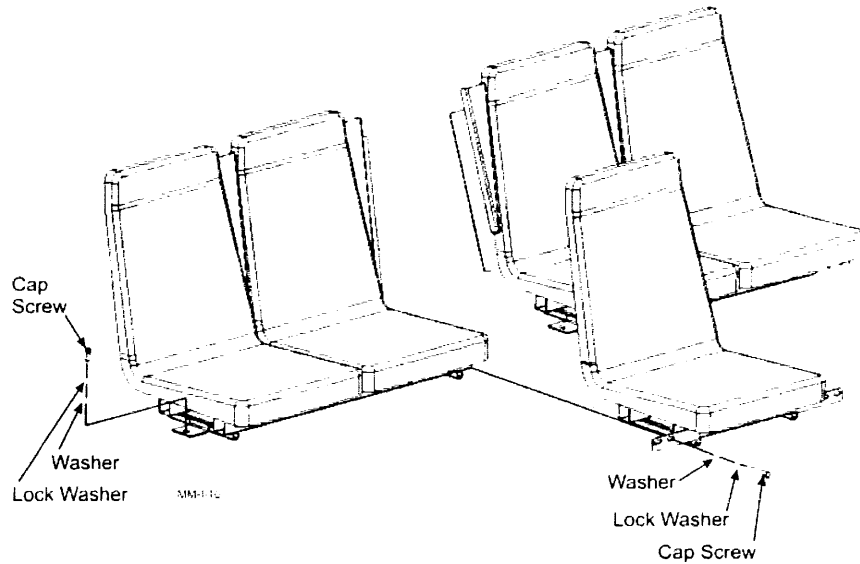
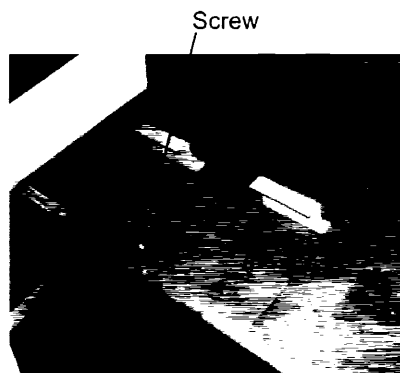

Figure 1. Access Panel

4. Remove the screws securing the engine access door to the floor. (Figure 2) When the door is removed pull insulation back to gain access to the engine.



S-H-1

Figure 2. Engine Access Door

Safety Bulletin

-
5. Use a $\frac{3}{8}$ " drive ratchet and a $\frac{1}{2}$ " socket to remove bolts securing the air governor to the bracket and discard the bolts. (Figure 3)

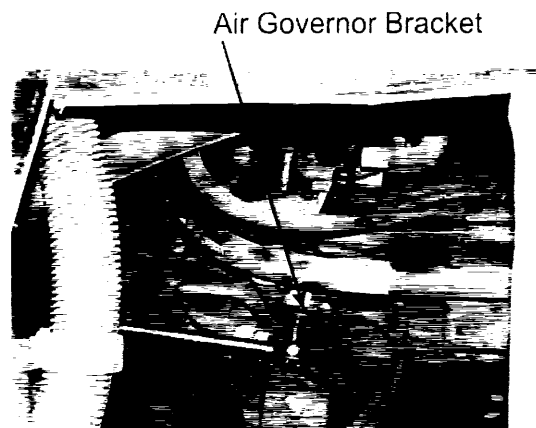

Figure 3. Air Governor Bracket

6. Place the new bracket against the governor bracket and line up the holes on the brackets and the governor and install the new bolts that are provided. (Use the existing washers and nuts)(Figure 4)

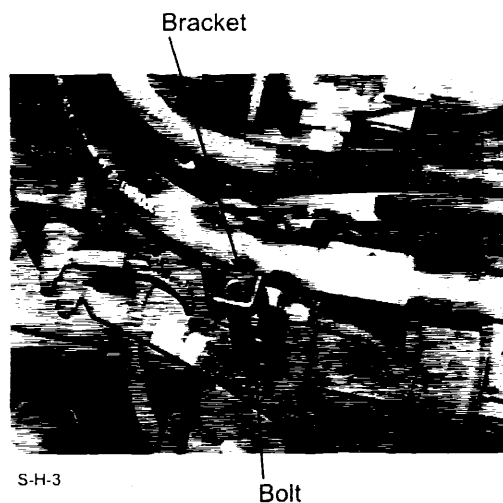
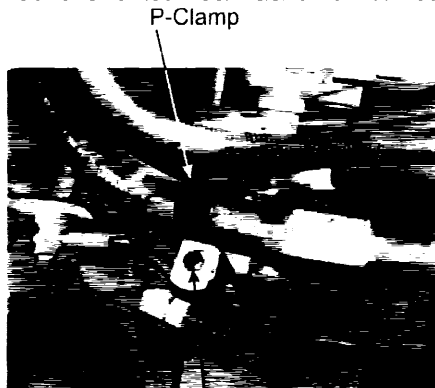

Figure 4. New Bracket Installation

Safety Bulletin

7. Place P-Clamp around the hydraulic hose and secure the p-clamp to the new bracket with a bolt, washer, lockwasher and nut. Lockwasher is installed on the nut side.(Figure 5)



S-H-4

Bolt, Washer, Lockwasher, Nut

Figure 5. P-Clamp Installation

8. Once the p-clamp is secured, line the bracket up straight and tighten the bolts to secure the whole assembly.



Figure 6. New Bracket Assembly



Safety Bulletin

If you experience any problems in complying with this Safety Recall or feel that you require assistance contact our Customer Service Department between the hours of 8:00 AM and 5:00 PM CST at 1-888-391-1777.

We regret any inconvenience that this action may cause you. However, we are concerned about your safety. If your dealer fails or is unable to remedy this defect without charge and within a reasonable time, you may submit a written complaint to the Administrator, National Highway Traffic Safety Administration, 400 Seventh Street, SW, Washington, DC 20590, or call the toll-free Auto Safety Hotline at 1-888-391-1777.

Sincerely,

OPTIMA BUS CORP.

A handwritten signature in black ink that reads 'Dan Scantlin'.

Dan Scantlin
Customer Service Manager