



GENERAL MOTORS NORTH AMERICA
 Structure & Safety Integration

RECEIVED

2005 APR 20 P 3: 14

April 19, 2005

OFFICE OF DEFECTS
 INVESTIGATION

05V-158
 (14 Pages)

Mr. Ronald Medford
 Senior Associate Administrator, Vehicle Safety
 National Highway Traffic Safety Administration
 400 Seventh Street, S.W., Room 5321
 Washington, D.C. 20590

Dear Mr. Medford:

The following information is submitted pursuant to the requirements of 49 CFR 573.6 as it applies to a determination by General Motors of a noncompliance involving certain 2002-2004 Saturn L-Series wagon model vehicles.

573.6(c)(1): Saturn Division of General Motors Corporation

573.6(c)(2)(3)(4): This information is shown on the attached sheet.

573.6(c)(5): Saturn has decided that 2002-2004 Saturn L-Series wagon vehicles were built with a center and passenger side rear seat belt anchor that fails to conform to Federal Motor Vehicle Safety Standard (FMVSS) 210, "Seat Belt Assembly Anchorages." The seat belt anchor may separate from the floor of the vehicle before holding the required test load for the required time. If a separation occurred in a crash, the right and center rear seat occupants may not be properly restrained, increasing the risk of personal injury.

573.6(c)(7): 573.6(c)(7): GM's determination is based on:

- On January 31, 2005, GM of Canada received a copy of a test report from Transport Canada along with a letter of inquiry. The test report documented the separation of the right hand center belt anchor in a CMVSS 210 test.
- During a GM test on March 21, 2005, the seat belt anchor separated from the vehicle with the test load at approximately 96% of the 210 requirement.

The GMNA Senior Management Committee, on April 8, 2005, recommended a field action, and on April 15, 2005, the Field Action Decision Committee decided to conduct a noncompliance recall.

573.6(c)(8): To correct this condition, Saturn retailers will install a rear seat center belt anchor reinforcement plate to the floor pan of the vehicle. This service will be performed at no cost to the owner.

Pursuant to 577.11(e), GM will not provide reimbursement to owners, according to the plan submitted on January 14, 2005. Owners would not know that this condition exists before receiving the recall notice.

573.6(c)(9): Attached is the final bulletin and owner letter. Saturn plans to notify retailers on April 19, 2005 and mail owner letters on April 22, 2005.

Sincerely,

Gay P. Kent
 Director

Product Investigations

05041
 Attachments



573.6(c)(2),(3),(4)

**VEHICLES POTENTIALLY AFFECTED BY MAKE, MODEL, AND MODEL YEAR
PLUS INCLUSIVE DATES OF MANUFACTURE**

<u>MAKE</u>	<u>MODEL SERIES</u>	<u>MODEL YEAR</u>	<u>NUMBER INVOLVED</u>	<u>INCLUSIVE MANUFACTURING DATES</u> <u>(FROM) (TO)</u>		<u>DESCRIPTIVE INFO. TO PROPERLY IDENT. VEH.</u>	<u>EST. NO. W/CONDITION</u>
Saturn	L	2002	11,255	06/2001	06/2002	L Series Wagon	All
Saturn	L	2003	7,228	06/2002	06/2003	L Series Wagon	All
Saturn	L	2004	2,218	06/2003	04/2004	L Series Wagon	All
		GM Total:	20,701				

05041

RECALL BULLETIN



NO.:	05041
	Non-Compliance
DATE:	April, 2005
CATEGORY TYPE:	Restraints - 09
CATEGORY:	Seat Belts - 40

F/C MVSS NON-COMPLIANCE RECALL

SUBJECT: INSTALLATION OF REAR SEAT CENTER BELT ANCHOR REINFORCEMENT PLATE

YEAR and MODEL: 2002-2004 SATURN L-SERIES WAGON VEHICLES

TO: ALL SATURN RETAILERS AND AUTHORIZED SERVICE PROVIDERS

The US National Traffic and Motor Vehicle Safety Act provides that each vehicle that is subject to a recall of this type must be adequately repaired within a reasonable time after the customer has tendered it for repair. A failure to repair within sixty days after tender of a vehicle is prima facie evidence of failure to repair within a reasonable time. If the condition is not adequately repaired within a reasonable time, the customer may be entitled to an identical or reasonably equivalent vehicle at no charge or to a refund of the purchase price less a reasonable allowance for depreciation.

To avoid having to provide these burdensome remedies, every effort must be made to promptly schedule an appointment with each customer and to repair their vehicle as soon as possible. In the recall notification letter, customers are told how to contact the US National Highway Traffic Safety Administration if the recall is not completed within a reasonable time.

CONDITION

Saturn has decided that 2002-2004 Saturn L-Series wagon vehicles were built with a center and passenger side rear seat belt anchor that fails to conform to Federal Motor Vehicle Safety Standard (FMVSS) 210, "Seat Belt Assembly Anchorages." The seat belt anchor may separate from the floor of the vehicle before holding the required test load for the required time. If a separation occurred in a crash, the right and center rear seat occupants may not be properly restrained, increasing the risk of personal injury.

CORRECTION

To correct this condition, Saturn retailers will install a rear seat center belt anchor reinforcement plate to the floor pan of the vehicle. This service will be performed at no cost to the owner.

SATURN bulletins are intended for use by professional technicians, NOT a "do-it-yourselfer." They are written to inform these technicians of conditions that may occur on some vehicles, or to provide information that could assist in the proper service of a vehicle. Properly trained technicians have the equipment, tools, safety instructions, and know-how to do a job properly and safely. If a condition is described, DO NOT assume that the bulletin applies to your vehicle, or that your vehicle will have that condition. See your **SATURN** Retailer for information on whether your vehicle may benefit from the information.

VEHICLES INVOLVED

2002-2004 model year Saturn L-Series wagon vehicles within the following VIN range will require this recall.

2Y500039 - 2Y600755

3Y500095 - 3Y581210

4Y500021 - 4Y521105

You must verify recall involvement through your AS400 system. It is important to note that recall claims will only be paid on involved vehicles.

OWNER NOTIFICATION

Owners of all involved vehicles located within areas covered by the US National Traffic and Motor Vehicle Safety Act will be notified of this recall by Saturn. (Refer to the owner letter included in this bulletin.)

RETAILER RESPONSIBILITY

All unsold new vehicles in Retailers' possession and subject to this recall must be held and inspected/repaired per the service procedure of this recall bulletin before customers take possession of these vehicles.

Retailers are to service all vehicles subject to this recall at no charge to customers, regardless of mileage, age of vehicle, or ownership, from this time forward.

Owners who have recently purchased vehicles sold from your vehicle inventory are to be contacted by the retailer and arrangements are to be made to make the required correction according to the procedure contained in this bulletin.

In summary, whenever a vehicle subject to this recall enters your vehicle inventory, or is in your retail facility for service in the future, you must take the steps necessary to be sure the recall correction has been made before selling or releasing the vehicle.

This bulletin is notice to you that the new motor vehicles included in this recall may not comply with the standard identified above. Under Title 49, Section 30112 of the United States Code, it is illegal for a dealer to sell a new motor vehicle which the dealer knows does not comply with an applicable Federal Motor Vehicle Safety Standard. As a consequence, if you sell any of these motor vehicles without first performing the recall correction, your dealership may be subject to a civil penalty for each such sale.

TRANSFER OF RECALL RESPONSIBILITY

Saturn vehicles that have been sold to you, which may be closer in proximity to another Saturn Retailer, may still appear on your Facility VIN Listing. If either you or the vehicle owner determines that it is more desirable for a vehicle on your Facility VIN Listing to be serviced by another Saturn Retailer, or if the customer's address has recently changed, recall responsibility may be transferred by completing the following:

- Submit a Recall Vehicle Action Report to your Customer Assistance Manager (CAM) at the Saturn Customer Assistance Center.

-OR-

- Submit an update in owner information to the Saturn Owner of Record system, via **SERVICELINE XL**, for Saturn Customer Assistance Center review and approval.

A copy of the Recall Vehicle Action Report is included for your reference. Additional copies can be ordered from Saturn Publications (win.wallace.com/saturn or 1-800-828-2112, prompt 3, Item # S03 2002RVAR). All changes to recall responsibility will be reflected in your next Unfixed VIN Report.

All other changes in vehicle status (e.g., scrapped, stolen, etc.) are to be made in accordance with section 4.4.3 of the Retailer Service Policies & Procedures Manual, "Notifying Saturn of Vehicle Status Change."



RECALL VEHICLE ACTION REPORT

VIN:	_____
RECALL NO(S):	_____
FACILITY CODE:	_____

CHANGE VEHICLE STATUS TO (PLACE AND [X] IN THE APPROPRIATE SPACE):

<input type="checkbox"/> VEHICLE STOLEN	VEHICLE STOLEN:	_____
	POLICE RPT NO:	_____
<input type="checkbox"/> VEHICLE SCRAPPED	DATE SCRAPPED:	_____
	SUPPORTING DOCUMENTATION:	_____
<input type="checkbox"/> OWNER UNRESPONSIVE/UNREACHABLE		
<input type="checkbox"/> VEHICLE TRADED TO:	RETAILER CODE:	_____
RETAILERS NAME: _____	EXPORT DEST.:	_____
<input type="checkbox"/> VEHICLE EXPORTED		

CHANGE OF OWNERSHIP INFORMATION:

_____ (OWNER FIRST NAME)	_____ (LAST NAME)
_____ (STREET ADDRESS)	
_____ (CITY, STATE/COUNTRY, ZIP CODE)	

COMMENTS:

THE ABOVE INFORMATION IS, TO THE BEST OF MY KNOWLEDGE, ACCURATE AND COMPLETE AS SHOWN, IN ACCORDANCE WITH THE RECALL REPORTING REQUIREMENTS UNDER FEDERAL MOTOR VEHICLE SAFETY STANDARDS.

_____ (AUTHORIZED RETAIL REPRESENTATIVE, TITLE)	_____ (CUSTOMER ASSISTANCE MANAGER OR DESIGNER)
--	---

CUSTOMER ASSISTANCE MANAGER APPROVAL (YES/NO) _____

IF NO, REASON: _____

WHEN COMPLETE:
 RETAILER: SEND TO CUSTOMER ASSISTANCE MANAGER:
 SATURN CUSTOMER ASSISTANCE CENTER
 100 SATURN PARKWAY MAIL CODE: 371-999-S24
 SPRING HILL, TN 37174

CUSTOMER ASSISTANCE MANAGER: SEND APPROVED FORMS TO RECALL COMPLIANCE COORDINATOR.
 SEND REJECTED FORMS, ALONG WITH REASON, BACK TO THE SUBMITTING RETAILER.

S03 2002RVAR

PARTS INFORMATION

1. A shipment of the required parts to perform this program will be automatically sent to involved Retailers from Saturn Service Parts Operations (SSPO).
2. Should you require any additional parts, please contact your Parts Support Analyst (PSA) to expedite parts shipment.

Part Number	Description	Quantity Required Per Vehicle
15810645	Plate — Rear Seat Belt Anchor Reinforcement (Kit)	1
21485277	Threadlocker — Loctite 242®	\$1.00 per vehicle* Billed as Net Item "M"

NOTE: All material prices are retailer cost plus 40%.

*One tube will service 10 vehicles. One tube \$9.93/10 vehicles = \$ 1.00 per vehicle.

Total Material Allowance is \$ 1.00 per vehicle.

DISPOSITION OF REPLACED PARTS

Retailers will scrap all replaced parts in a manner that ensures that they cannot be reused, remanufactured, or otherwise entered into the stream of commerce in the future.

SUGGESTIONS FOR ENSURING CUSTOMER SATISFACTION

As you know, Saturn's success hinges upon our ability to execute superior customer support throughout the ownership experience, especially when important corrective actions such as this are required.

It is imperative that every effort is made to accommodate the affected owners. Additionally, priority should be given to customer vehicles over retail inventory vehicles. If you have any questions, please coordinate with the Saturn Customer Assistance Center to help ensure customer satisfaction.

SERVICE PROCEDURE OVERVIEW

In order to install the rear seat center belt anchor reinforcement plate to the floor pan of the vehicle, removal of the following interior parts is required: rear seat cushion, passenger side rear folding seat back, two 8 mm (0.315 in) child seat anchor plate assembly bolts, one 11.11 mm (7/16 in) seat belt anchor bolt, and a fiber retainer (if applicable) and buckle/latch assembly. No special tools are required to perform the service procedures in this bulletin.

Refer to the illustration below to view the floor pan, child seat anchor plate, and rear seat center belt anchor reinforcement plate.

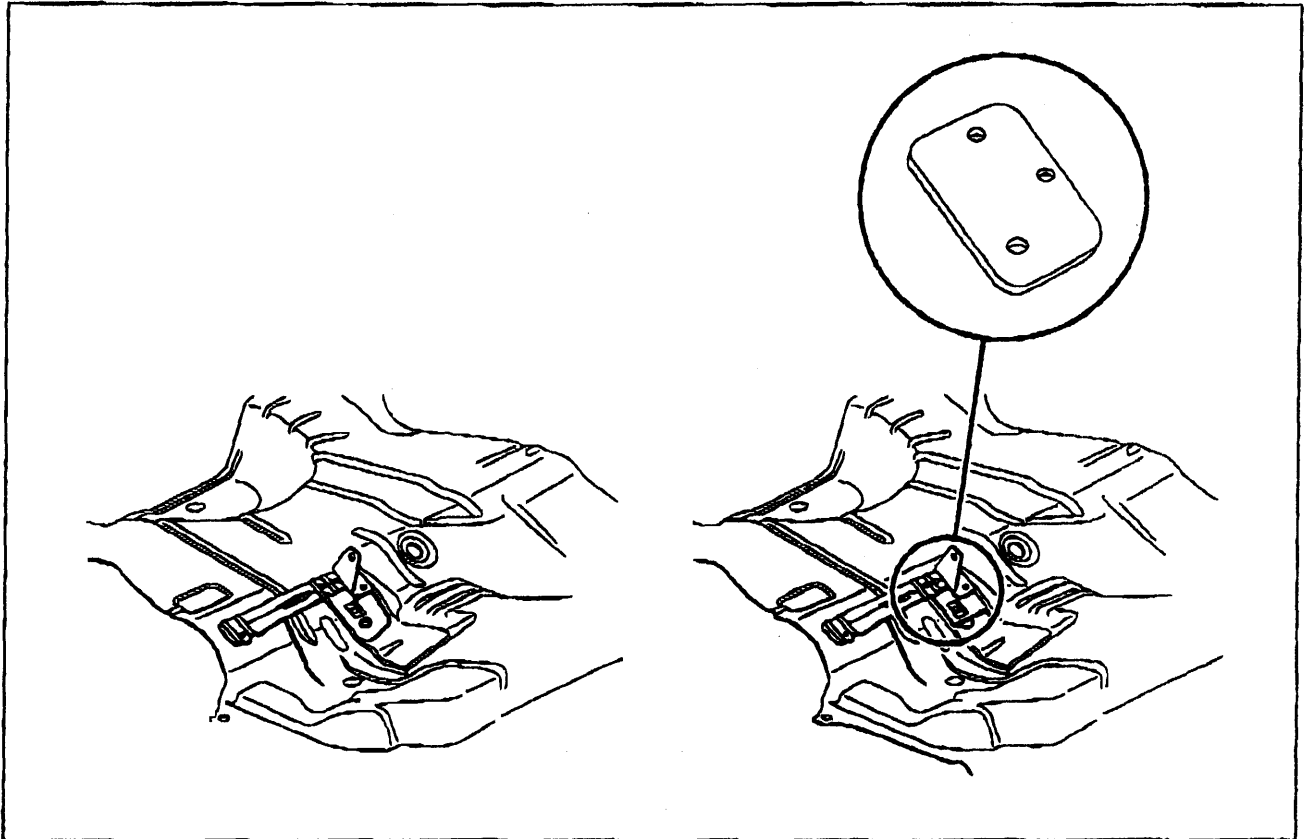

SERVICE PROCEDURE

IMPORTANT: There are two rear seat cushion retainer straps, which are located on the bottom of the driver's and passenger's side of the rear seat cushion. If they are not exposed, insert a finger between the bottom of the rear seat cushion and the floor to locate them.

1. Remove rear seat cushion.
 - 1.1 Pull on rear seat cushion retainer strap while pulling up on cushion to disengage rear seat cushion forward attachment. Perform the same operation for the other side of the seat cushion.
 - 1.2 Push rear seat cushion rearward to disengage rear attachment.
 - 1.3 Route seat belts through rear seat cushion opening and lift rear seat cushion out of vehicle.
2. Remove passenger's side rear folding seat back.
 - 2.1 Push up on seat back foam with your hand to expose seat bracket outer retainer.
 - 2.2 Unlatch rear seat back. Leave seat in upward position.

NOTICE: Rear seat back attachments have an "Easyload" outer bracket that allows the rear seat back to snap into position upon installation. It is necessary to pry on the bottom of the bracket (where the large pivot pin goes into the seat bracket) to disengage the rear seat back attachment.

- 2.3 Gently pry on the bottom of the bracket ① while pulling upward on the seat back to disengage outer bracket from pivot pin ②.
- 2.4 Tilt seat back down to align inner pivot tabs then pull seat back outward to remove seat back.

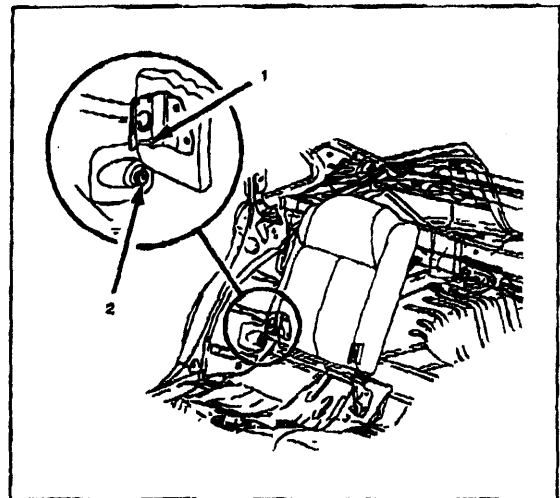
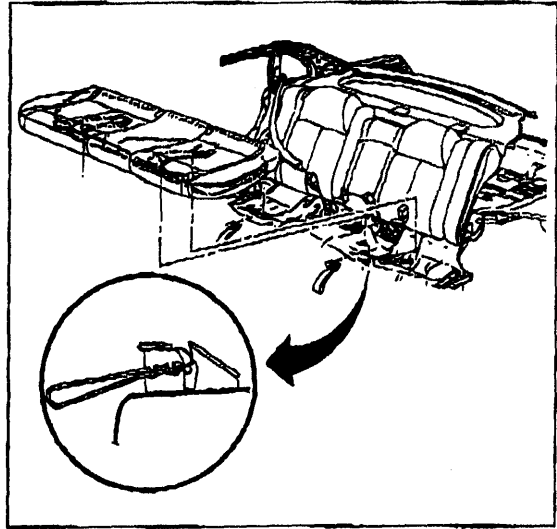

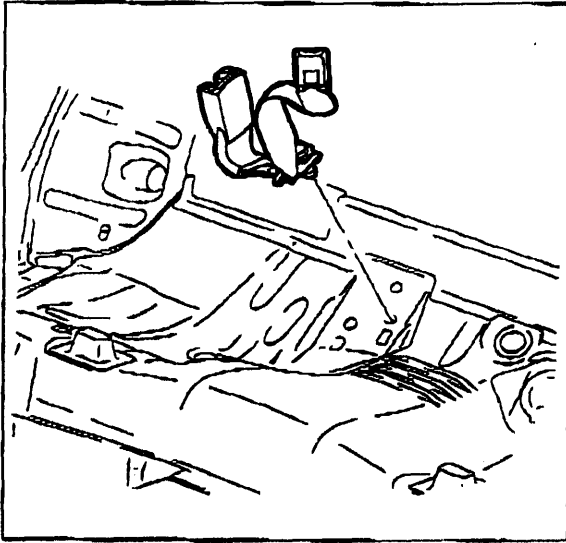

3. Remove buckle/latch assembly, fiber retainer, seat belt bolt, child seat anchor plate assembly bolts, and install the rear seat center belt anchor reinforcement plate (P/N 15796153).

3.1 Remove 11.11 mm (7/16 in) seat belt bolt and fiber retainer (if applicable) from the buckle/latch assembly.

3.2 Remove the two 8 mm (0.315 in) bolts from the child seat anchor plate assembly.

3.3 Slide the rear seat center belt anchor reinforcement plate (P/N 15796153) under the child seat anchor plate assembly.

CAUTION: APPLY LOCTITE 242 THREADLOCKER® (OR EQUIVALENT) ON 8 MM (0.315 in) BOLTS BEFORE INSTALLATION.

3.4 Install two new 8 mm (0.315 in) child seat anchor plate assembly bolts, P/N 90585162, at the pivot bracket.

Tighten:

Tighten child seat anchor plate assembly bolts to
 $25 \pm 5 \text{ N}\cdot\text{m}$ (18 lb-ft \pm [44 in-lbs]).

NOTICE: Ensure the belt is not twisted by buckling the center and outboard seating positions after the seat back assembly and seat cushion have been installed. Push and pull on the seat belt system to ensure it is secure.

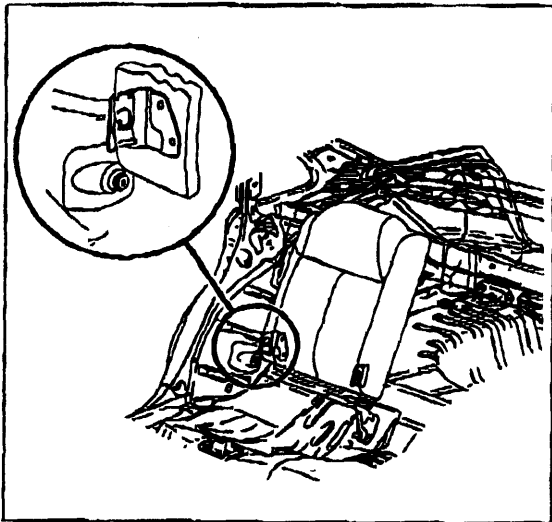

3.5 Install buckle/latch assembly and new 11.11 mm (7/16 in) seat belt bolt, P/N 90583861.

Tighten:

Tighten seat belt bolt to
 $42 \pm 6 \text{ N}\cdot\text{m}$ (31 lb-ft \pm [53 in-lbs]).

4. Install passenger's side rear folding seat back.

4.1 Guide seat back assembly onto center pivot pin.

4.2 Align outer pivot pin with the lead in ramp on the "Easyload" bracket.

4.3 Push downward on the seat back to engage "Easyload" bracket.

4.4 Raise seat back and secure seat back latch.

5. Install rear seat cushion.

5.1 Position rear seat cushion over rear seat floor area.

5.2 Route rear seat belts through cushion openings.

5.3 Slide rear seat cushion frame into rear attachment brackets.

5.4 Push downward on rear seat cushion forward retainers to lock rear seat cushion to floor brackets.

5.5 Check seat belt for proper routing through cushion.

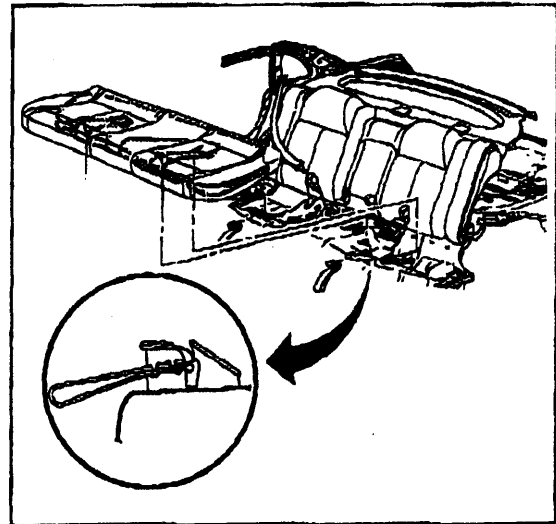

CREDIT

1. To receive credit, submit a claim with the information below:

Repair Performed	Parts Allow.	Sale Type	Case Type	Labor Op.	Labor Hrs.	Admin. Hrs.****
Install Rear Seat Center Belt Anchor Reinforcement Plate	*	WC	VC	V1348	0.4	0.1

* The parts allowance should be the sum total of the current SSPO Retailer net price plus 40% of all parts required for the repair.

**** Administrative allowance.

Claiming Loctite 242 Threadlocker® Material

It will be necessary to sell these materials to the CSO as "material" using net item code "M" per the chart on page 5 of this bulletin. Claims received in the amount of \$1.00 will be accepted. Claims exceeding the amount of \$1.00 will be returned with Return Reason 143 - material/reimbursement > maximum allowed.

2. To receive credit for loaner/rental vehicle costs incurred while owner awaits program repair, submit a claim with the information below:

Repair Performed	Sale Type	Case Type	Labor Op.	Net Item Amount	Net Item Code	# Days Rental
Loaner/Rental Reimbursement	WC	VC	V1349	**	C	***

3. Check your Saturn **SERVICELINE.XL** Claim Memorandum daily. Remember to code the claim as a WC sale type, and VC case type. Contact your field representative if you need assistance.

4. All labor operations claimed in this bulletin must be submitted on individual (unrelated) CSO lines. Refer to the Customer Service Order Preparation Manual for details on Bulletin Claim Submission.

** Net amount must be submitted as a miscellaneous sale...Loaner/rental reimbursement not to exceed \$35/day

*** Enter number of days vehicle was rented...Not to exceed 1 day

The completed Loaner/Rental Worksheet must be attached to the hard copy of the Customer Service Order (CSO)



April, 2005

Dear Saturn Owner,

This notice is sent to you in accordance with the requirements of the National Traffic and Motor Vehicle Safety Act.

Saturn has decided that 2002-2004 Saturn L-Series wagon vehicles were built with a center and passenger side rear seat belt anchor that fails to conform to Federal Motor Vehicle Safety Standard (FMVSS) 210, "Seat Belt Assembly Anchorages." The seat belt anchor may separate from the floor of the vehicle before holding the required test load for the required time. If a separation occurred in a crash, the right and center rear seat occupants may not be properly restrained, increasing the risk of personal injury.

What Saturn will do:

To correct this condition, Saturn retailers will install a rear seat center belt anchor reinforcement plate to the floor pan of the vehicle. This service will be performed at no cost to the owner.

Repairs will take about 60 minutes although some additional time may be required due to service scheduling requirements, paperwork and processing. This service will be performed at no charge to you.

What you should do:

Contact your Saturn Retailer as soon as possible to arrange to have this service performed.

The enclosed reply card identifies your vehicle and will facilitate completion of the service when presented to your Saturn retail facility. If your address has changed, please provide the new information in the space provided. This will assist us in ensuring that all affected vehicles are corrected.

Your Retailer is prepared to perform this service promptly and with minimal inconvenience to you. However, if your car is provided to the Retailer on the agreed service date and the condition is not remedied on that date, or within a reasonable time, please contact the Saturn Customer Assistance Center at 1-800-972-8876, or for the hearing impaired, 1-800-833-6000. We will assist you and the Retailer in getting your car serviced.

Federal regulation requires that any vehicle lessor receiving this recall notice must forward a copy of this notice to the lessee within ten days.

We sincerely regret any inconvenience or concern this situation may cause you. We want you to know that we will do our best, throughout your ownership experience, to ensure that your Saturn provides you many miles of enjoyable and safe driving.

Sincerely,

Saturn

05041

Enclosures

05041 LOANER/RENTAL WORKSHEET

Complete this worksheet and attach it to the hard copy of the Customer Service Order (CSO) to document all loaner/rental reimbursement claims submitted to Saturn.

VIN # _____

Vehicle Loaner/Rental Allowance Explanation: \$ _____

Repair Performed	Sale Type	Case Type	Labor OP	Net Item Code	# Days Rental
Loaner/Rental Reimbursement	WC	VC	V1349	C	*

* Not to exceed \$35/day for 1 day

Authorized Retailer Signature

(Please copy this form as necessary)