

Mazda North American Operations



TO: All Mazda Dealership General Managers, Service Managers, and Parts Managers

DATE: March 2005

SUBJECT: 2004-2005 Tribute Lift Gate Latch Recall 2804L

Mazda Motor Corporation has decided that certain 2004-2005 Tribute vehicles produced between June 2, 2003 through July 30, 2004 and certain 2001-2003 Tribute Vehicles repaired during dealer service with defective lift gate latch assemblies fail to conform to the inertia load requirements of Federal Motor Vehicle Safety Standard (FMVSS) No. 206, Door Locks and Door Retention Components.

On certain 2004-2005 model year Tribute vehicles, the lift gate latching system does not comply with Federal Motor Vehicle Safety Standard (FMVSS) 206 inertia load requirements. If repairs were made to the lift gate latching system on your 2001-2003 Tribute, your vehicle is equipped with defective lift gate parts. If the lift gate is left unlocked, there is the potential it may open during a severe crash, which could result in injuries to the occupant.

Owners of affected vehicles will be notified by first class mail beginning March 31, 2005.

This package contains important information about recall campaign 2804L:

Attachment I Dealer Service and Parts information
Attachment II Inspection and Repair procedures
Attachment III Owner Notification Letter
Dealer Report

The National Traffic and Motor Vehicle Safety Act prohibits the delivery of any subject vehicle without performing the necessary repair for defects or failures. Failure to perform applicable recalls before sale can result in extensive dealer fines and penalties from the Federal Government. Therefore, you must complete this recall for all affected new vehicles in your inventory prior to delivery.

Dealers should complete Recall 2804L for affected new and pre-owned Tributes in dealer inventory.

To help you effectively perform this recall, Mazda has developed the following resources:

1. Service and Parts recall instructions follow (Attachment I), were e-mailed to your Service Department, and are also available on eMDCS and the ESI website.
2. Inspection and repair procedures follow (Attachment II), and are also available on the ESI and eMDCS website.
3. We recommend using the enclosed report of registered owners in the dealer's area to encourage customers to come in for the recall (with recall reminder postcards). Dealers may use such owner

information for the sole purpose of conducting and performing this safety recall, and for no other purpose. Using it for marketing activities is strictly prohibited and could subject **your dealership to serious fines.** The information in this report is protected by state privacy and other applicable laws regarding disclosure of personal and/or confidential, restricted or blocked information. It is the dealer's responsibility to protect the confidentiality of owner records and prevent the release of information to other parties.

In California, privacy laws prevent the release of names and addresses on this report.

4. For technical assistance, call the Technical Assistance Hotline at (888) 832-8477.
5. For warranty questions, contact the Corporate Dealer Assistance Group at (877) 727-6626.

Please make certain that the appropriate personnel in your dealership are aware of these resources and are familiar with the details of this recall before responding to customer inquiries.

We apologize for any inconvenience this program may cause you and your customers. Please keep in mind that owners of 2001 and newer models are eligible to receive a rental car at no charge. Your understanding and support in carrying out this campaign is greatly appreciated.

Sincerely,

A handwritten signature in black ink that reads "Michael J. Giblin". The signature is written in a cursive style with a large initial "M".

Michael J. Giblin
Director, Technical Services
Mazda North American Operations

ATTACHMENT I – DEALER INFORMATION

CONDITION OF CONCERN

Mazda Motor Corporation has decided that certain 2004-2005 Tribute vehicles produced between June 2, 2003 through July 30, 2004 and certain 2001-2003 Tribute vehicles repaired during dealer service with defective lift gate latch assemblies fail to conform to the inertia load requirement of Federal Motor Vehicle Safety Standard (FMVSS) No. 206, Door Locks and Door Retention Components.

SUBJECT VEHICLES

Model	VIN Range
2001-2003 Tribute	4F2*****1KM00001-3KN99999

Model	VIN Range	Build Date Range
Tribute 2004 2005	4F2*Z** ** 4K M00004 - M34822 4F2*Z** ** 5K M00003 - M22946	June 2, 2003 through July 30, 2004

Note: The asterisk symbol "*" can be any letter or number.

Dealers should complete Recall 2804L for affected new and pre-owned Tributes in dealer inventory

OWNER NOTIFICATION

Mazda will notify U.S. owners by first class mail beginning March 31, 2005.

PARTS INFORMATION

Description	Part Number	Quantity	
Lift Gate Latch Repair Kit	EFY1-62-31X	1	
Authorized Modification Label	9999-95-065A-00	1=sheet of 18 labels	Mstore (no charge)

PARTS ORDERING

Dealers will automatically receive a quantity of Lift Gate Latch Repair Kits based on the number of 2004-2005 Tribute vehicles registered in the dealer's area. Parts shipments will begin March 25, 2005 and will arrive on dealers' next stock order. Dealers will receive Lift Gate Latch Repair Kits by April 1, 2005.

If dealers need additional Lift Gate Latch Repair Kits after receiving the initial parts shipment, they can be ordered through the normal eMDCS parts order method after April 1, 2005. **NOTE: To assure all dealers can get parts when needed, we may require an IPFAX form or online order form in the future if PDC inventory becomes low.**

Existing Service Parts Inventory

Please return any inventory you have of EC02-62-410H, EF20-62-310, EF20-62-310A, EF20-62-310B on your next obsolescence return and you will receive credit on your next parts statement. The return of these parts will not go against your obsolescence accrual.

Use MStore to order additional Campaign labels (1=sheet of 18 labels).

WARRANTY CLAIM PROCESSING INFORMATION

Warranty Type Code	R
Symptom Code	99
Damage Code	99
Process Number	J0502A
Part Number Main Cause	EFY16231X
Quantity	01
Labor Operation Code	YY376XRX
Labor Hours	0.4

RENTAL CAR

A rental car may be provided to the customer if eligible based on the terms and conditions of the Rental Car Reimbursement Program, policy 12.0. Rental car reimbursements are available only on 2001 and newer vehicles within the mileage and time limitations under the New Vehicle Limited Warranty. If the customer was placed in a rental car while the campaign was being completed and the vehicle is not within the mileage and time limitations, you must obtain authorization for the rental. Submit a separate **claim/problem** using the standard rental claim information.

Warranty Type Code	A
Symptom Code	99
Damage Code	99
Part Number Main Cause	5555-RE-NTAL
Part Quantity	0
Labor Operation Code	MM012XRX
Labor Hours	0.0
Sublet – Rental Car	
Sublet Invoice Number	Number from Rental Invoice or Dealer Purchase Order
Sublet Type Code	Enter "L"
Sublet Amount	Up to \$26.00 per day for the number of days customer had rental car

Rental expenses that exceed the two-day limit will require prior DCSM Authorization, as outlined in the Rental Car Reimbursement Program policy.

VERIFY THE VEHICLE NEEDS THE RECALL

1. Verify the vehicle is within the following ranges:

Model	VIN Range	Build Date Range
Tribute 2004 2005	4F2*Z*** 4K M00004 - M34822 4F2*Z*** 5K M00003 - M22946	June 2, 2003 through July 30, 2004

If the vehicle is within the above ranges, go to step 2.

If vehicle is not within the above range, return it to inventory or the customer.

2. Perform a Warranty Vehicle Inquiry using your eMDCS System and inspect vehicle for an Authorized Modification Label RECALL 2804L attached to the vehicle's bulkhead.

eMDCS System - Vehicle Status Inquiry Results

If eMDCS displays:	Campaign Label is:	Action to perform:
RECALL 2804L	Present	Contact the Mazda Corporate Dealer Assistance Group at (877) 727-6626 to update vehicle history
	Not present	Proceed to "REPAIR PROCEDURE"
RECALL 2804L CLOSED	Present	Return vehicle to inventory or customer
	Not present	Complete a label and apply to vehicle's hood or bulkhead
RECALL 2804L is not displayed	Does not apply	SSP does not apply to this vehicle. Return vehicle to inventory or customer

Note: Verify the recall number as the vehicle may have multiple labels.

REPAIR PROCEDURES

Please refer to Attachment II.

TRIBUTE LIFTGATE LATCH [RECALL 2804L]

A. VEHICLE INSPECTION PROCEDURE

1. Verify the vehicle is within one of the following ranges:

- 2001-2003 Tribute vehicles

VIN Ranges:

2001-2003 Tribute 4F2*****1KM00001 – 3KN99999

2004-2005 Tribute vehicles built between June 2, 2003 through July 30, 2004.

VIN Ranges:

2004 Tribute 4F2*Z****4KM00004 – M34822

2005 Tribute 4F2*Z****5KM00003 – M22946

- If the vehicle is within one of the above ranges, proceed to step 2.
- If the vehicle is not within one of the above ranges, return vehicle to the customer or inventory.

2. Perform a Warranty Vehicle Inquiry using your eMDCS System and inspect vehicle for an Authorized Modification Label **Recall 2804L** attached to the vehicle's hood. Refer to eMDCS System - Warranty Vehicle Inquiry Results table below.

NOTE: Be sure to verify RECALL number as the vehicle may have multiple Recall labels.

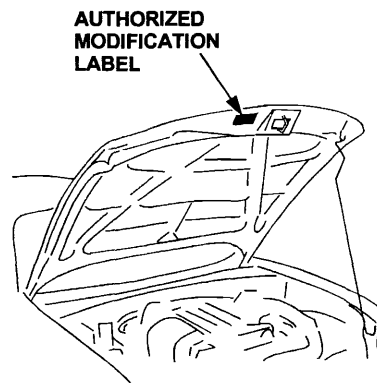

eMDCS System - Warranty Vehicle Inquiry Results:

If eMDCS displays:	Campaign Label is:	Action to perform:
RECALL 2804L OPEN	Present	Contact the Mazda Corporate Dealer Assistance Group at (877) 727-6626 to update vehicle history.
	Not present	Proceed to "B. REPAIR PROCEDURE".
RECALL 2804L CLOSED	Present	Return vehicle to inventory or customer.
	Not present	Complete a label and apply to vehicle's hood.
RECALL 2804L is not displayed	Does not apply	Recall does not apply to this vehicle. Return vehicle to inventory or customer.

B. REPAIR PROCEDURE

OVERVIEW

This program involves performing specific liftgate latch system repairs on two (2) specific vehicle populations. Each repair procedure identifies the affected vehicles requiring that particular repair. See the list below for specific repairs needed for each vehicle population.

2004 model year Tribute vehicles and 2001-2003 Tribute vehicles serviced with subject parts:

- replace the liftgate latch release rod
- replace release rod clip
- replace handle assembly return spring and circlip

2005 model year Tribute vehicles:

- replace the liftgate latch release rod
- replace release rod clip

LIFTGATE HANDLE REMOVAL AND REPAIR

AFFECTED VEHICLES: 2004 MODEL YEAR TRIBUTE VEHICLES AND 2001-2003 MODEL YEAR TRIBUTE VEHICLES SERVICED WITH SUBJECT PARTS

1. Open the liftgate.
2. If equipped, remove the rear wiper motor cover.
3. Remove the four (4) screws and remove the liftgate trim panel.
4. Disconnect the liftgate window latch, liftgate handle, and liftgate latch release rods by opening the clips.

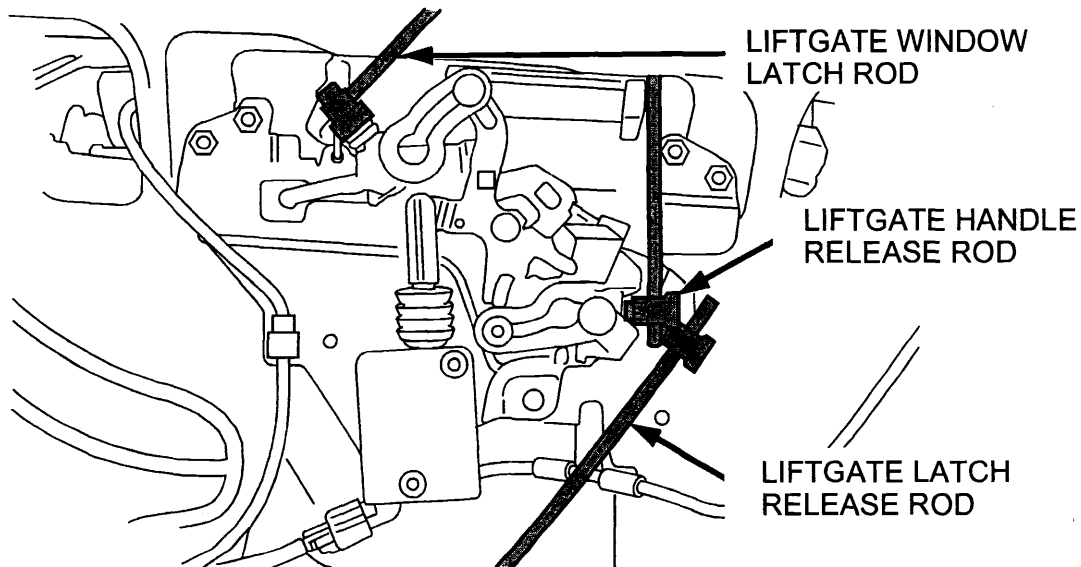

2804La

**ATTACHMENT II
[RECALL 2804L]**

5. Release the liftgate window latch ajar switch wiring harness locator and if equipped, disconnect the liftgate latch actuator electrical connector.

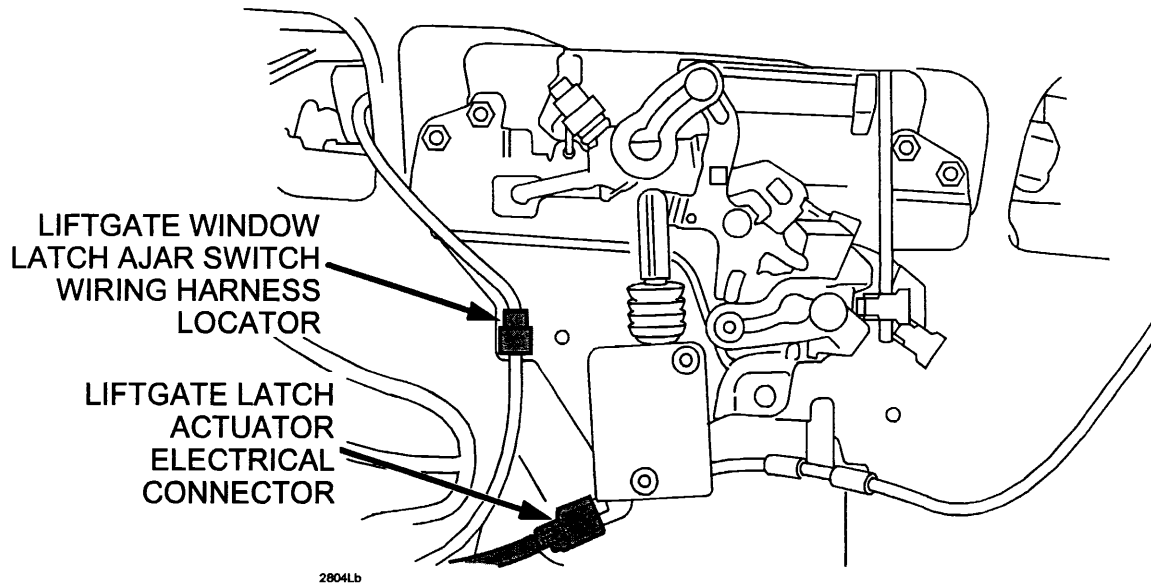

6. Remove the liftgate latch remote control assembly retaining screw and all four (4) retaining nuts.

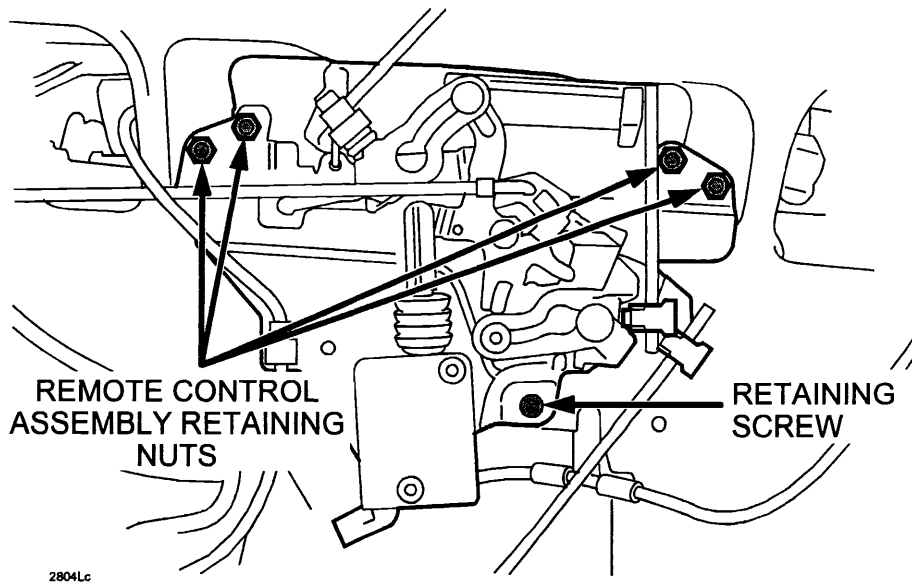

**ATTACHMENT II
[RECALL 2804L]**

7. Disconnect the liftgate handle-to-remote release rod from the remote control assembly, then remove the remote control.

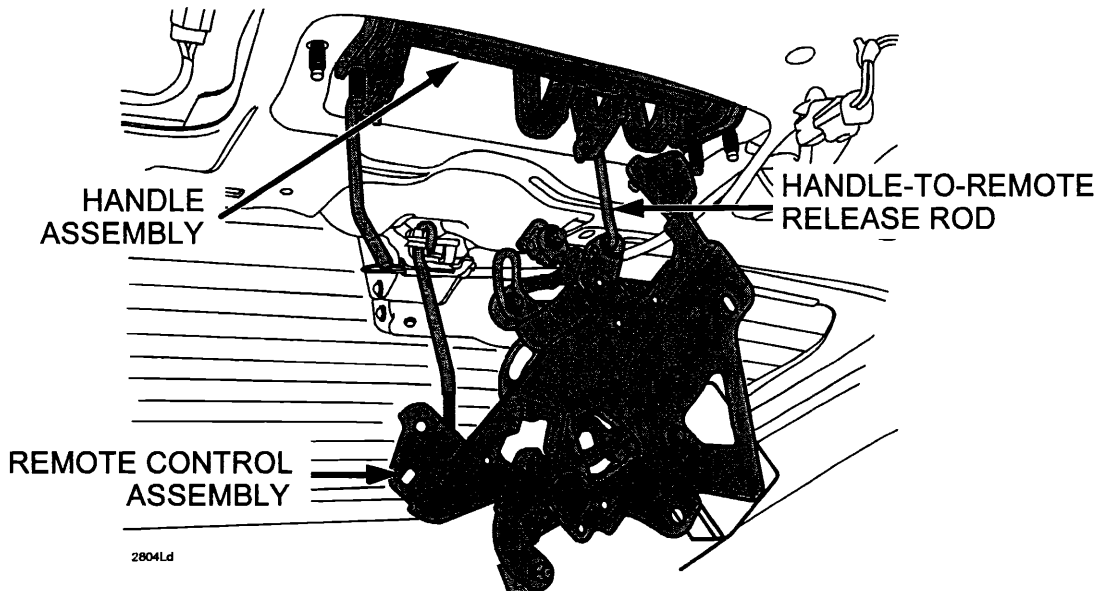

8. Remove the liftgate handle assembly and place it on a bench.
9. Disassemble the handle as follows:
 - a. Remove the circlip from the end of the pivot rod.
 - b. Pull the pivot rod out of the handle assembly.
 - c. Note the position of the spring then remove the spring from the handle assembly.

**ATTACHMENT II
[RECALL 2804L]**

10. Install the *new* spring and circlip to the original pivot rod and handle.

NOTE: The *new* circlip is supplied in the bag with the *new* spring. Make sure to retain the *new* circlip for installation to the original pivot rod and handle.

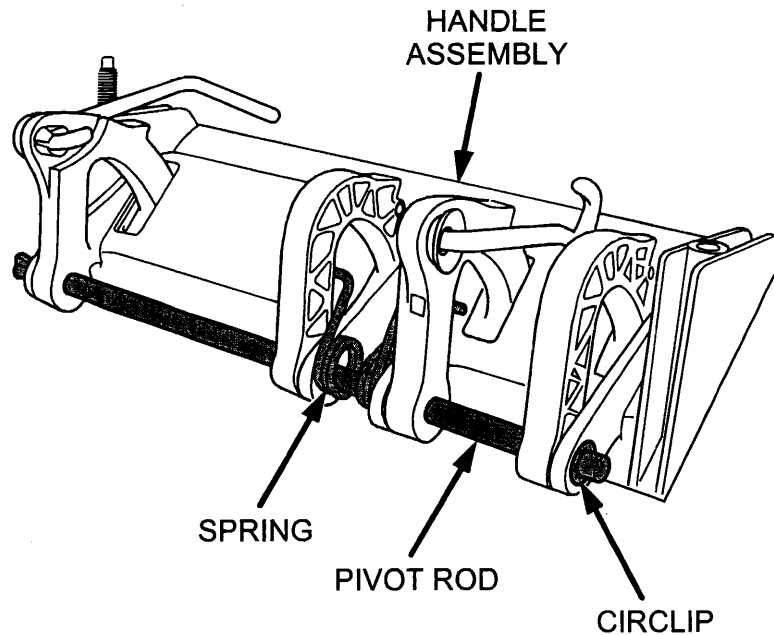

LIFTGATE LATCH REMOVAL AND RELEASE ROD REPLACEMENT

AFFECTED VEHICLES: ALL VEHICLES COVERED BY RECALL 2804L

NOTE: For 2001-2004 model year vehicles, proceed to Step 4.

For 2005 model year vehicles, begin this repair from Step 1.

1. Open the liftgate.
2. If equipped, remove the rear wiper motor cover.
3. Remove the four (4) screws and remove the liftgate trim panel.
4. Disconnect the liftgate ajar switch electrical connector (located on the liftgate switch).
5. Remove the three (3) liftgate latch bolts and retain.
6. Remove the liftgate latch.

7. Remove the liftgate latch release rod and install the *new* rod.

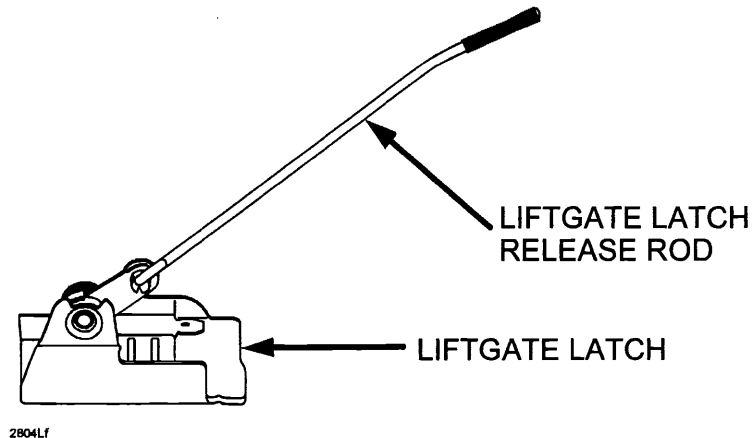

8. Remove the original release rod clip and replace with the *new* clip.

LIFTGATE LATCH INSTALLATION

AFFECTED VEHICLES: ALL VEHICLES COVERED BY RECALL 2804L

1. Position the latch assembly in the vehicle.
2. Apply (locally obtained) Permatex Medium Strength Threadlocker (blue), to the bolts and install the three (3) liftgate latch bolts.
Tightening Torque: 5 Nm (44 lb-in)

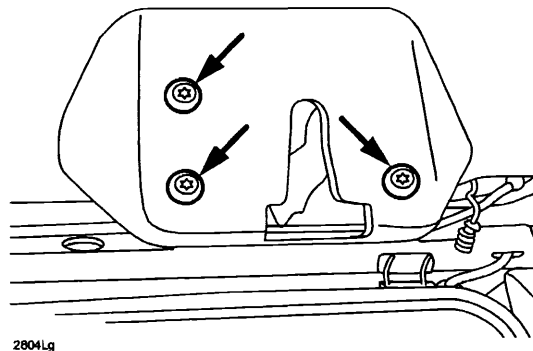

3. Connect the liftgate ajar switch electrical connector.

NOTE: For 2001-2004 model year vehicles, proceed to "Liftgate Handle Installation."
For 2005 model year vehicles, proceed to Step 4.

4. Install the liftgate trim panel and four (4) screws.
5. If equipped, install the rear wiper motor cover.
6. Close the liftgate.

LIFTGATE HANDLE INSTALLATION

AFFECTED VEHICLES: 2001-2004 MODEL YEAR VEHICLES

1. Position the handle assembly in the vehicle.
2. Connect the liftgate handle-to-remote release rod to the remote control assembly.

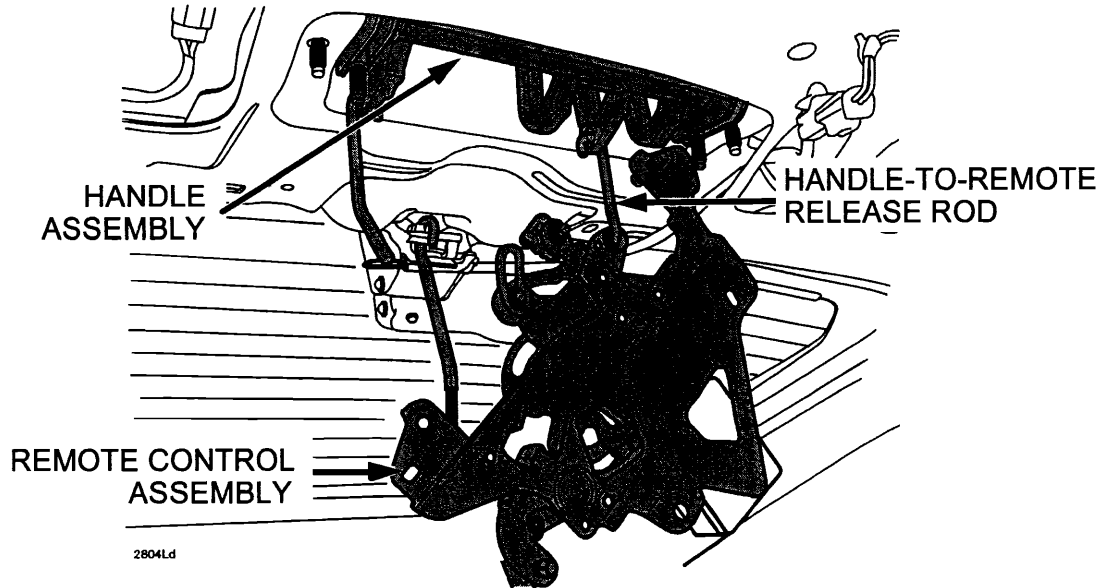

3. Install all four (4) nuts and the retaining screw.
Tightening Torque: 7 Nm (62 lb-in)

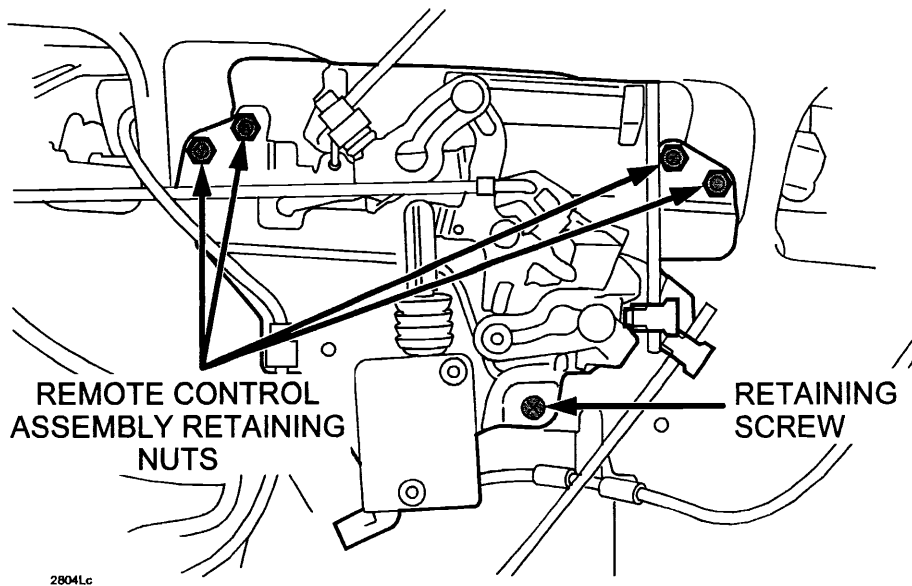

**ATTACHMENT II
[RECALL 2804L]**

4. Secure the liftgate window latch ajar switch wiring harness locator and connect the liftgate latch actuator electrical connector.

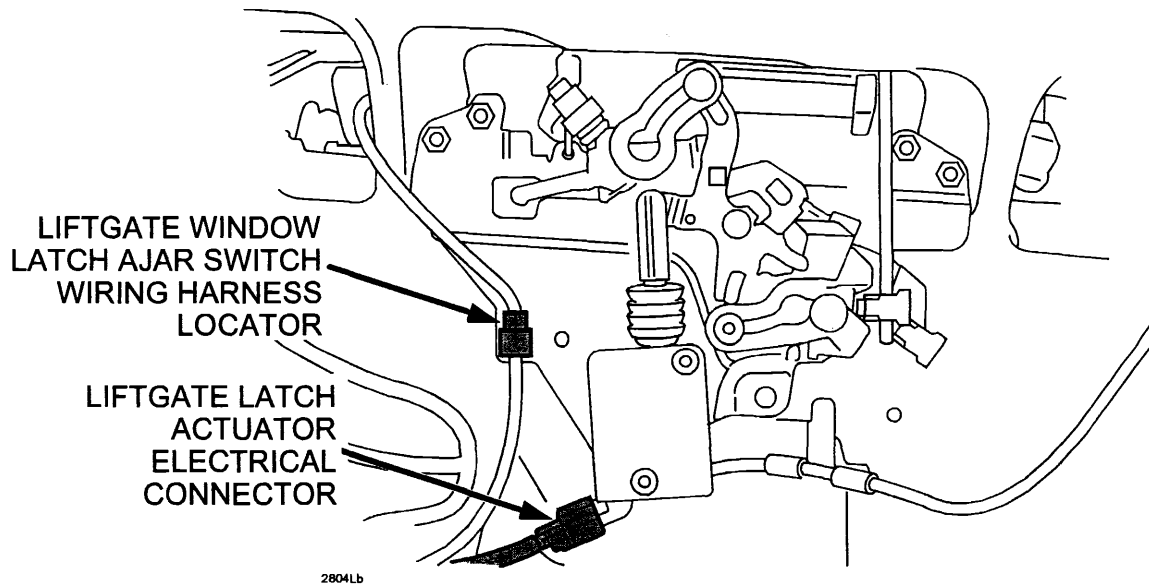

5. Connect the liftgate handle actuating rod and the liftgate window latch release rods.
NOTE: Be sure the latch rods are not binding or putting pressure on the latches when connected.

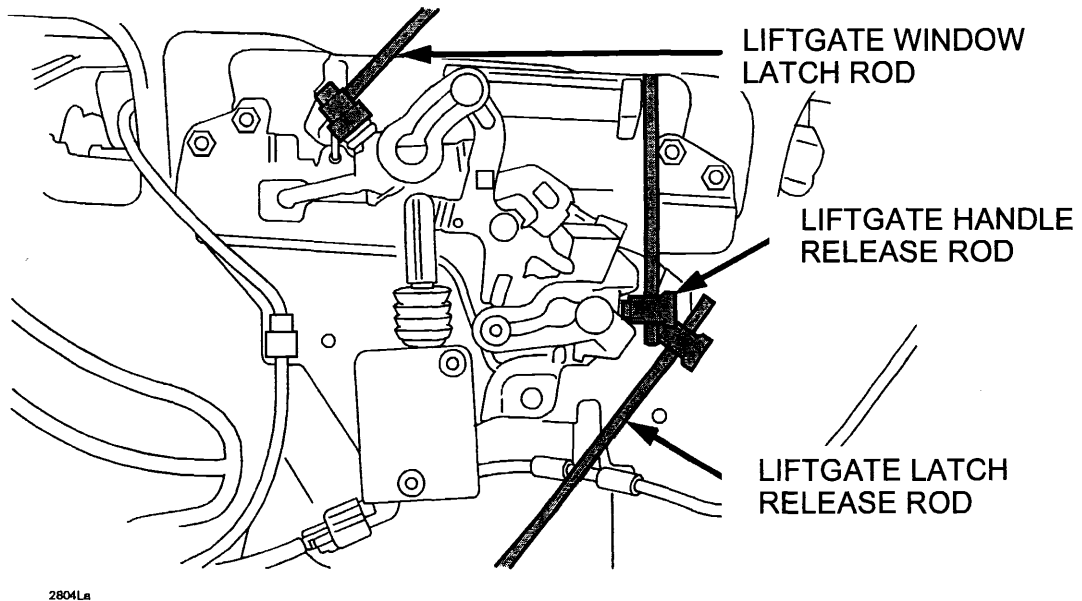

6. Open and close the liftgate and the liftgate glass a few times to verify correct operation of the liftgate and liftgate window latches.
7. Install the liftgate trim panel and install the screws.
8. If equipped, install the rear wiper motor cover.
9. Close the liftgate.

C. AUTHORIZED MODIFICATION LABEL INSTALLATION

Complete an "Authorized Modification Label" with the Recall number written on the sticker and affix it to the vehicle's hood. Refer back to the illustration under "A. VEHICLE INSPECTION PROCEDURE".

ATTACHMENT III – OWNER NOTIFICATION LETTER
2004-2005 MODEL YEARS

Mazda North American Operations



March 2005

2004-2005 Tribute Lift Gate Latch Recall 2804L

Dear Mazda Owner:

This notice is being sent to you in accordance with the requirements of the National Traffic and Motor Vehicle Safety Act.

Mazda Motor Corporation has decided that certain 2004-2005 Tribute vehicles produced between June 2, 2003 through July 30, 2004 fail to conform to the inertia load requirement of Federal Motor Vehicle Safety Standard (FMVSS) No. 206, Door Locks and Door Retention Components. **If you are a recipient of this notice, your vehicle is included in this recall.**

What is the problem?

On certain 2004-2005 model year Tribute vehicles, the lift gate latching system does not comply with Federal Motor Vehicle Safety Standard (FMVSS) 206 Inertia Load requirements. If the lift gate is left unlocked, there is the potential it may open during a severe crash, which could result in injuries to the occupant.

What will Mazda do?

Your Mazda dealer will inspect the lift gate latching system, and if necessary, replace the affected parts **free of charge**. The repair should take approximately one-half day to complete. However, it may take longer depending on the service workload at your Mazda dealership.

As a reminder, the Mazda Driver's Assurance Plan may provide alternate transportation when your vehicle is at an authorized Mazda dealership for a warranty repair. To be eligible for alternate transportation, your vehicle must be a 2001 or newer model and within the mileage and time limitations under the Mazda New Vehicle Limited Warranty and adhere to the Rental Car Reimbursement policy. Ask your dealer for details about the Mazda Rental Car Reimbursement Program.

What should you do?

Mazda is concerned about your safety, and we encourage you to make an appointment with any authorized Mazda dealer to have the lift gate latching system inspected and the affected parts replaced, if necessary, as soon as possible. You do not need to bring this notice to the dealer, but it may assist in the check-in process.

What if you have already paid for a replacement lift gate latch?

If you have already paid for the inspection or replacement of the affected lift gate latch parts due to a defect, you may be eligible for reimbursement of reasonable repair expenses based on Mazda's repair standards. Please complete the enclosed "Reimbursement Application Form," including the necessary documentation, and mail it to us in the pre-addressed envelope provided, allowing 6-8 weeks for processing.

Where is the closest Mazda dealer?

To locate your nearest Mazda dealer, visit our web site and try our "Locate a Dealer" feature at www.MazdaUSA.com or consult your local yellow pages.

Moved or no longer own this vehicle?

If you have moved or no longer own your Tribute, please complete the enclosed prepaid *Information Change Card* as soon as possible. This enables us to update our records and notify the current owner.

Federal law requires that any vehicle lessor receiving this recall notice must forward a copy of this notice to the lessee within ten days.

Still have questions?

If you have any questions regarding this campaign, please contact our Customer Assistance Center at (800) 222-5500, option #4.

If Mazda or its dealers do not repair the defect free of charge and within a reasonable amount of time, you may notify the Administrator of the National Highway Traffic Safety Administration, 400 Seventh Avenue, SW, Washington, D.C. 20590. You may also call their toll-free Auto Safety Hotline at (888) 327-4236.

Your safety is a priority for Mazda. We actively work to improve our products and search for solutions to improve your ownership experience. Please accept our apologies for any inconvenience this program may have caused you.

Sincerely,

Mazda North American Operations

**OWNER NOTIFICATION LETTER
2001-2004 TRIBUTE MODELS**

Mazda North American Operations



March 2005

2001-2003 Tribute Lift Gate Latch Recall 2804L

Dear Mazda Owner:

This notice is being sent to you in accordance with the requirements of the National Traffic and Motor Vehicle Safety Act.

Mazda Motor Corporation has decided that certain 2001-2003 Tribute vehicles repaired during dealer service with defective lift gate latch assemblies fail to conform to the inertia load requirement of Federal Motor Vehicle Safety Standard (FMVSS) No. 206, Door Locks and Door Retention Components. **If you are a recipient of this notice, your vehicle is included in this recall.**

What is the problem?

On certain 2001-2003 model years Tribute vehicles, the lift gate latching system does not comply with Federal Motor Vehicle Safety Standard (FMVSS) 206 Inertia Load requirements. If repairs were made to the lift gate latching system on your 2001-2003 Tribute, your vehicle is equipped with defective lift gate parts. If the lift gate is left unlocked, there is the potential it may open during a severe crash, which could result in injuries to the occupant.

What will Mazda do?

Your Mazda dealer will inspect the lift gate latching system, and if necessary, replace the affected parts **free of charge**. The repair should take approximately one-half day to complete. However, it may take longer depending on the service workload at your Mazda dealership.

As a reminder, the Mazda Driver's Assurance Plan may provide alternate transportation when your vehicle is at an authorized Mazda dealership for a warranty repair. To be eligible for alternate transportation, your vehicle must be a 2001 or newer model and within the mileage and time limitations under the Mazda New Vehicle Limited Warranty and adhere to the Rental Car Reimbursement policy. Ask your dealer for details about the Mazda Rental Car Reimbursement Program.

What should you do?

Mazda is concerned about your safety, and we encourage you to make an appointment with any authorized Mazda dealer to have the lift gate latching system inspected and the affected parts replaced, if necessary, as soon as possible. You do not need to bring this notice to the dealer, but it may assist in the check-in process.

What if you have already paid for a replacement lift gate latch?

If you have already paid for the inspection or replacement of the affected lift gate latch parts due to a defect, you may be eligible for reimbursement of reasonable repair expenses based on Mazda's repair standards. Please complete the enclosed "Reimbursement Application

Form,” including the necessary documentation, and mail it to us in the pre-addressed envelope provided, allowing 6-8 weeks for processing.

Where is the closest Mazda dealer?

To locate your nearest Mazda dealer, visit our web site and try our “Locate a Dealer” feature at www.MazdaUSA.com or consult your local yellow pages.

Moved or no longer own this vehicle?

If you have moved or no longer own your Tribute, please complete the enclosed prepaid *Information Change Card* as soon as possible. This enables us to update our records and notify the current owner.

Federal law requires that any vehicle lessor receiving this recall notice must forward a copy of this notice to the lessee within ten days.

Still have questions?

If you have any questions regarding this campaign, please contact our Customer Assistance Center at (800) 222-5500, option #4.

If Mazda or its dealers do not repair the defect free of charge and within a reasonable amount of time, you may notify the Administrator of the National Highway Traffic Safety Administration, 400 Seventh Avenue, SW, Washington, D.C. 20590. You may also call their toll-free Auto Safety Hotline at (888) 327-4236.

Your safety is a priority for Mazda. We actively work to improve our products and search for solutions to improve your ownership experience. Please accept our apologies for any inconvenience this program may have caused you.

Sincerely,

Mazda North American Operations