

Ford Motor Company
RECEIVED
NVS-215

2005 FEB 17 A 10: 07

OFFICE OF
DEFECTS INVESTIGATION

James P. Vondale, Director
Automotive Safety Office
Environmental & Safety Engineering

February 16, 2005

Mr. George Person, Chief
Recall Management Division (NVS-215)
Office of Defects Investigation
National Highway Traffic Safety Administration
400 Seventh Street, S.W.
Washington, DC 20590

Dear Mr. Person:

Subject: Safety Recall 04V-604
(Ford Number 04S26)

Pursuant to the requirements set forth in Part 573 of Title 49 of the Code of Federal Regulations -- Defect and Noncompliance Reports, Ford Motor Company is submitting a true or representative copy of information that relates directly to the subject campaign.

Attached are dealer and owner letters issued by Ford Customer Service Division regarding a recall of certain 2005 model year Ford GT vehicles. Specific details were submitted to you in a letter dated December 20, 2004. Owner notification letters were mailed on January 14, 2005.

Sincerely,



J. P. Vondale

Attachment(s)
04S26 Dealer-Owner Bulletin





Frank M. Ligon
Director
Service Engineering Operations
Ford Customer Service Division

Ford Motor Company
P. O. Box 1904
Dearborn, Michigan 48121

December 16, 2004

TO: Certain U.S. Ford Dealers (who have received/sold a Ford GT)

SUBJECT: DEMONSTRATION / DELIVERY HOLD / DO NOT DRIVE: Safety Recall 04S26
All 2005 Ford GT Vehicles
Suspension Control Arm Replacement

DEMONSTRATION / DELIVERY HOLD: Emission Recall 04E14
Certain 2005 Ford GT Vehicles
Fuel Tank Date Code Inspection

AFFECTED VEHICLES

Safety Recall 04S26: All 2005 Ford GT vehicles built at the Wixom Special Vehicle Center from Job #1 through December 9, 2004.

Emission Recall 04E14: Certain 2005 Ford GT vehicles built at the Wixom Special Vehicle Center from October 13, 2004 through November 19, 2004.

Affected vehicles are identified in OASIS. In addition, for a list of vehicles assigned to your dealership, visit <https://web.fsavinlists.dealerconnection.com>. This information will be available on December 16, 2004.

REASON FOR THESE RECALLS

SAFETY RECALL 04S26: Ford has identified a quality issue with the suspension control arms on the affected vehicles which may adversely affect vehicle handling in the event of control arm fracture. In the event a customer does not seek service for the diminished handling concern, a crash potentially could occur.

EMISSION RECALL 04E14: In some of the affected vehicles, the fuel tank may not pass applicable state and Federal evaporative emission standards.

SERVICE ACTION

DO NOT DEMONSTRATE, DELIVER, OR DRIVE any of the affected vehicles involved in these recalls. A dealer bulletin with additional instructions will be posted when parts and technical instructions are available in January 2005.

CUSTOMER NOTIFICATION

Owners of 2005 Ford GT vehicles will be contacted directly by a Ford representative beginning December 16, 2004; owners will be advised to not drive their vehicle under any circumstances.

OASIS ACTIVATED? Yes. OASIS will be activated by December 16, 2004.

FSA VIN LIST ACTIVATED? Yes

Available through FMCDDealer.com or at <https://web.fsavinlists.dealerconnection.com> by December 16, 2004. FSA VIN listings for unsold vehicles will be available December 16, 2004.

NOTE: Your FSA VIN list may contain owner names and addresses obtained from motor vehicle registration records. The use of such motor vehicle registration data for any purpose other than in connection with this recall is a violation of law in several states, provinces, and countries. Accordingly, you must limit the use of this listing to the follow-up necessary to complete this recall action.

PLEASE NOTE:

Federal law requires dealers to complete any outstanding safety recall service before a new vehicle is delivered to the buyer or lessee. Violation of this requirement by a dealer could result in a civil penalty of up to \$5,000 per vehicle. Correct all vehicles in your new vehicle inventory prior to delivery

QUESTIONS?

Special Service Support Center (Dealer Only) Questions:..... 1-800-325-5621

Sincerely,



Frank M. Ligon



Frank M. Ligon
Director
Service Engineering Operations
Ford Customer Service Division

Ford Motor Company
P. O. Box 1904
Dearborn, Michigan 48121

January 5, 2005

TO: **New!** All U.S. Ford and Lincoln Mercury Dealers
SUBJECT: **DEMONSTRATION / DELIVERY HOLD / DO NOT DRIVE:** Safety Recall 04S26 and
Emission Recall 04E14 – Status Update

REF: **DEMONSTRATION / DELIVERY HOLD / DO NOT DRIVE:** Safety Recall 04S26
All 2005 Ford GT Vehicles
Suspension Control Arm Replacement
DELIVERY HOLD: Emission Recall 04E14
Certain 2005 Ford GT Vehicles
Fuel Tank Date Code Inspection

New!

STATUS UPDATE:

Parts Availability:

Please be advised that this Demonstration / Delivery Hold / Do Not Drive restriction will remain in effect until service parts are available for 04S26, which is now targeted for February, 2005.

Customer Communication/Service Appointments:

Ford SVT Marketing has been in contact with the affected vehicle owners and, once service parts are available for 04S26, will coordinate scheduling service appointments between the owner and the dealer.

Transportation of Affected Vehicles:

Ford SVT Marketing will also coordinate arrangements between customers, dealers and carriers for transportation of affected vehicles in enclosed trailers from the customer's site to the dealership and back after repairs have been completed. Dealers will be authorized to charge vehicle transportation charges to the 04S26 program.

Rental Vehicles:

Dealers are authorized to provide affected customers with a luxury rental vehicle until repairs have been completed (rentals not subject to standard daily limitations). Dealers will be authorized to charge vehicle rental costs to the 04S26 program.

Customer Letters:

Customer Notification Letters will be mailed to affected owners the week of 1/17/05.

AFFECTED VEHICLES

Safety Recall 04S26: All 2005 Ford GT vehicles built at the Wixom Special Vehicle Center from Job #1 through December 9, 2004.

Emission Recall 04E14: Certain 2005 Ford GT vehicles built at the Wixom Special Vehicle Center from October 13, 2004 through November 19, 2004.

Affected vehicles are identified in OASIS. In addition, for a list of vehicles assigned to your dealership, visit <https://web.fsavinlists.dealerconnection.com>. This information will be available on December 16, 2004.

REASON FOR THESE RECALLS

SAFETY RECALL 04S26: Ford has identified a quality issue with the suspension control arms on the affected vehicles which may adversely affect vehicle handling in the event of control arm fracture. In the event a customer does not seek service for the diminished handling concern, a crash potentially could occur.

EMISSION RECALL 04E14: In some of the affected vehicles, the fuel tank may not pass applicable state and Federal evaporative emission standards.

SERVICE ACTION

Do NOT DEMONSTRATE, DELIVER, OR DRIVE any of the affected vehicles involved in these recalls. A dealer bulletin with additional instructions will be posted when parts and technical instructions are available (targeted for February 2005).

CUSTOMER NOTIFICATION

Owners of 2005 Ford GT vehicles will be contacted directly by a Ford representative beginning December 16, 2004; owners will be advised to not drive their vehicle under any circumstances.

OASIS ACTIVATED? Yes. OASIS will be activated by December 16, 2004.

FSA VIN LIST ACTIVATED? Yes

Available through FMCDDealer.com or at <https://web.fsavinlists.dealerconnection.com> by December 16, 2004. FSA VIN listings for unsold vehicles will be available December 16, 2004.

NOTE: Your FSA VIN list may contain owner names and addresses obtained from motor vehicle registration records. The use of such motor vehicle registration data for any purpose other than in connection with this recall is a violation of law in several states, provinces, and countries. Accordingly, you must limit the use of this listing to the follow-up necessary to complete this recall action.

PLEASE NOTE:

Federal law requires dealers to complete any outstanding safety recall service before a new vehicle is delivered to the buyer or lessee. Violation of this requirement by a dealer could result in a civil penalty of up to \$5,000 per vehicle. Correct all vehicles in your new vehicle inventory prior to delivery

QUESTIONS?

Call the Ford GT Program Team.....1-800-367-3788

Sincerely,

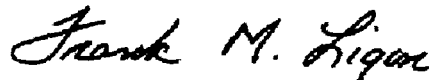

Frank M. Ligon



Frank M. Ligon
Ford Motor Company
P. O. Box 1904
Dearborn, Michigan 48121

January 2005

Safety Recall 04S26

Mr. John Sample
123 Main Street
Anywhere, USA 12345

Your Vehicle Identification Number: 12345678901234567

This notice is sent to you in accordance with the requirements of the National Traffic and Motor Vehicle Safety Act.

Ford Motor Company has decided that a defect which relates to motor vehicle safety exists in certain 2005 Ford GT vehicles.

We apologize for this situation and want to assure you that, with your assistance, we will correct this condition. Our commitment, together with Ford dealers, is to provide you with the highest level of service and support.

What is the issue? Ford has identified a quality issue with the suspension control arms on the affected vehicles which may result in a control arm fracture. In the event of a control arm fracture, vehicle handling may be diminished and a crash potentially could occur without prior warning.

What will Ford and your dealer do? Ford Motor Company and your dealer will replace the suspension control arms on your vehicle free of charge (parts and labor).

How long will it take? Once parts are available, the time needed for this repair is two to three days.

What are we asking you to do?

Your vehicle should not be driven until this recall service has been performed.

The Ford Special Vehicle Team (SVT) has been contacting owners of affected vehicles via phone. If you have not already been contacted, please call the Ford SVT Information Center at 1-800-367-3788 without delay.

Once parts become available, Ford SVT will coordinate making a service appointment for your vehicle with the dealer of your choice. In addition, Ford SVT will arrange for your vehicle to be transported in an enclosed carrier to have the service performed. Estimated timing for part availability is in February 2005.

Please note: Federal law requires that any vehicle lessor receiving this recall notice must forward a copy of this notice to the lessee within ten days.

Do you need a rental vehicle?

Your dealer is authorized to provide you with a luxury rental vehicle at no charge (except for fuel and insurance) until your vehicle has been repaired.

Have you changed your address or sold the vehicle?

If you have, please notify the Ford SVT Information Center at 1-800-367-3788 so that we can update our records.

Can we assist you further?

If you have difficulty getting your vehicle repaired promptly and without charge, please contact the Ford SVT Information Center at 1-800-367-3788.

If you are still having difficulty getting your vehicle repaired in a reasonable time or without charge, you may write the Administrator, National Highway Traffic Safety Administration, 400 Seventh Street S. W., Washington, D. C. 20590 or call the toll free Auto Safety Hotline at 1-888-327-4236 or 1-800-424-9393.

Thank you for your attention to this important matter.

Sincerely,

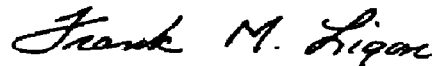

Frank M. Ligon
Director
Service Engineering Operations



Frank M. Ligon
Director
Service Engineering Operations
Ford Customer Service Division

Ford Motor Company
P. O. Box 1904
Dearborn, Michigan 48121

February 2005

TO: All U.S. Ford and Lincoln Mercury Dealers

SUBJECT: **DEMONSTRATION / DELIVERY HOLD:** Safety Recall 04S26 – Supplement #1
Certain 2005 Ford GT Vehicles
Suspension Control Arm Replacement

REF: **DEMONSTRATION / DELIVERY HOLD / DO NOT DRIVE:** Safety Recall
Bulletin 04S26 dated December 16, 2004

REF: **DELIVERY HOLD:** Emissions Recall Bulletin 04E14 dated January 2005.

AFFECTED VEHICLES

Certain 2005 Ford GT vehicles built at the Wixom Special Vehicle Center from Job #1 through December 9, 2004. Affected vehicles are identified in OASIS. In addition, for a list of vehicles assigned to your dealership, visit <https://web.fsavinlists.dealerconnection.com>. This information was made available on December 16, 2004.

REASON FOR THIS SAFETY RECALL

Ford has identified a quality issue with the suspension control arms on the affected vehicles that may adversely affect vehicle handling in the event of control arm fracture. In the event a customer does not seek service for the potential handling concern, a crash may occur.

SERVICE ACTION

At no charge to the vehicle owner, dealers are to replace the upper and lower control arm at each wheel position on all affected vehicles. **DO NOT DEMONSTRATE OR DELIVER** any of the affected vehicles involved in this safety recall until this recall service is performed.

NOTES:

- Some vehicles affected by 04S26 (Suspension Control Arm Replacement) are also involved in Emissions Recall 04E14 (Fuel Tank Date Code Inspection).
- Ford SVT is directly contacting all owners affected by Safety Recall 04S26 and Emission Recall 04E14. Customer Letters were mailed January 19, 2005.
- The Ford SVT team is scheduling repair dates for the customer directly with dealers and will arrange for transportation of the vehicle to the servicing dealership in an enclosed carrier.

In an effort to maintain high levels of owner satisfaction with the Ford GT, the following related service actions should also be performed while the vehicle is at the dealership.

SERVICE ACTION (Continued)

- **Emissions Recall 04E14 (Fuel Tank Date Code Inspection):** Check OASIS and perform this Emissions Recall on all affected vehicles. Service action includes an inspection and possible fuel tank replacement. Submit claims under program code 04E14.
- **Technical Service Bulletins (TSBs):** Dealers are authorized to perform the inspections, and if necessary, complete the repairs for the following Technical Service Bulletins. The objective is to complete the open recalls and perform applicable TSBs during a single visit to the dealer. Submit TSB repairs on a regular warranty claim.
 - TSB 04-25-06: Leakage From Transaxle Cooler Bypass Line
 - TSB 04-26-09: Power Steering Fluid Leak at Cooler
 - TSB 04-25-03: Rattle From Upper Steering Column

NOTE: TSBs should only be performed after having first received permission from the vehicle owner.

- To assist dealers in performing the repairs associated with 04S26, 04E14 (if applicable) and the recommended TSB inspections and repairs, please refer to the following process flowchart.

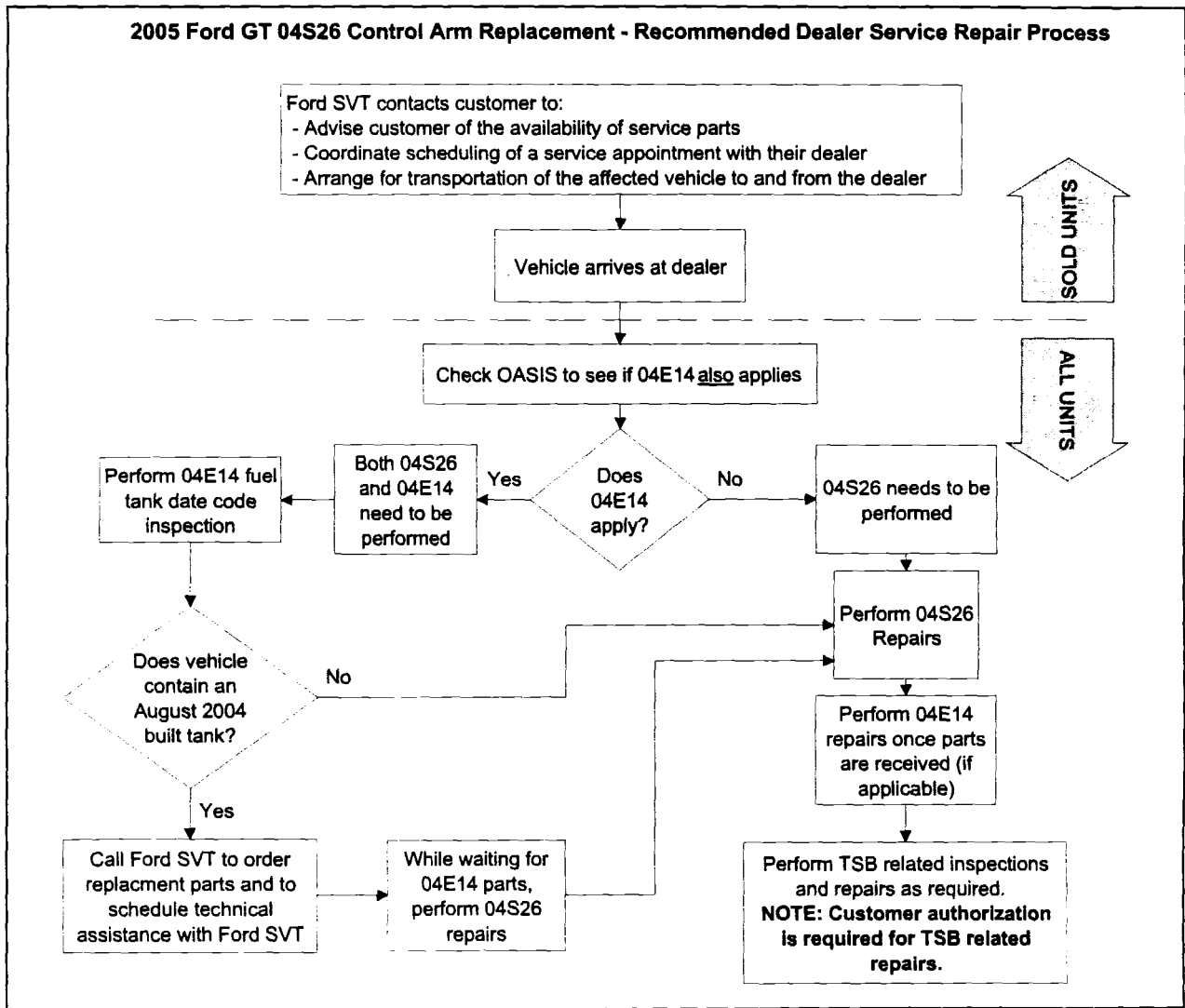

CUSTOMER NOTIFICATION

On January 19, 2005, notification letters were mailed to all owners of record.

Ford SVT has been in contact with the affected vehicle owners and is coordinating the scheduling of service appointments between the owner and the dealer to have both 04S26 and 04E14 (if applicable) recall programs performed at the same time.

ESTIMATED REMEDY DATE

Servicing customer's vehicles is our first priority. We anticipate having an adequate supply of parts to service all customer owned vehicles by February 28, 2005. At that time, we will begin to automatically ship parts to dealers to service their in-stock vehicles. These in-stock vehicle orders will be prioritized based upon vehicle build date, with parts for the earliest vehicles being shipped first. We estimate that all affected vehicles will have the necessary replacement parts by March 31, 2005.

PLEASE NOTE:

Federal law requires dealers to complete any outstanding safety recall service before a new vehicle is delivered to the buyer or lessee. Violation of this requirement by a dealer could result in a civil penalty of up to \$5,000 per vehicle. Correct all vehicles in your new vehicle inventory before delivery.

ATTACHMENTS

- Attachment I: Administrative Information
- Attachment II: Labor Allowances and Parts Ordering Information
- Attachment III: Technical Information
- Attachment IV: Dealer Q & A
- Customer Notification Letter

QUESTIONS?

- Claims Information: 1-800-423-8851
- Special Service Support Center (Dealer Only) Questions: 1-800-325-5621
- Ford SVT Information Center: 1-800-367-3788

Sincerely,



Frank M. Ligon

**DEMONSTRATION / DELIVERY HOLD: Safety Recall 04S26 – Supplement #1
Certain 2005 Ford GT Vehicles
Suspension Control Arm Replacement**

OASIS ACTIVATED? Yes. OASIS was activated December 16, 2004.

FSA VIN LIST ACTIVATED? Yes

Available through FMCDealer.com or at <https://web.fsavinlists.dealerconnection.com>. This information was made available December 16, 2004. FSA VIN listings for unsold vehicles was also made available December 16, 2004.

NOTE: Your FSA VIN list may contain owner names and addresses obtained from motor vehicle registration records. The use of such motor vehicle registration data for any purpose other than in connection with this recall is a violation of law in several states, provinces, and countries. Accordingly, you must limit the use of this listing to the follow-up necessary to complete this recall action.

STOCK VEHICLES

Correct all affected units in your new vehicle inventory before delivery.

NOTE: Part availability is limited at this time, and servicing customer's vehicles is our first priority. We anticipate having an adequate supply of parts to service all customer owned vehicles by the end of February. At that time, Ford will automatically begin to ship parts to dealers to service their in-stock vehicles. These in-stock vehicle orders will be prioritized based upon vehicle build date, with parts for the earliest built vehicles being shipped first.

SOLD VEHICLES

Ford SVT has been in contact with the affected vehicle owners and is coordinating the scheduling of service appointments between the owner and the dealer to have both 04S26 and 04E14 (if applicable) recall programs performed at the same time.

Ford SVT will also coordinate arrangements between customers, dealers and carriers for transportation of affected vehicles in enclosed trailers from the customer's site to the dealership and back after repairs have been completed. Charges for the transportation of customer vehicles will be handled directly between the vehicle transport companies and Ford Motor Company. Dealers should not incur any charges for vehicle transportation, however if there is a question, please contact the Ford SVT Information Center at 1-800-367-3788.

TITLE BRANDED / SALVAGED VEHICLES

Affected title branded and salvaged vehicles are eligible for this Field Service Action.

RENTAL VEHICLES

Dealers are authorized to provide affected customers with a luxury rental vehicle for the entire duration of time that their vehicle is out of service. This includes time out of service for both recall and TSB repairs. Rental vehicles for this program are not subject to standard daily limitations.

**DEMONSTRATION / DELIVERY HOLD: Safety Recall 04S26 – Supplement #1
Certain 2005 Ford GT Vehicles
Suspension Control Arm Replacement**

CLAIMS PREPARATION AND SUBMISSION

- Enter claims using Direct Warranty Entry (DWE).
- All repairs for 04S26 and 04E14 must use actual time (MT).
- All TSB related repairs must use actual time (MT). TSB repairs must be submitted on a regular warranty claim. Do not claim any TSB related repairs against either Emission Recall 04E14 or Safety Recall 04S26.
- The use of MT (actual time) must comply with warranty and policy guidelines as outlined in the Warranty and Policy Manual. "Actual Time" repairs require technician time stamps on the Repair Order. (See "Time Recording Procedure" on page 14 of Section 1 in the Warranty and Policy Manual.)
- Refer to ACESII manual for claims preparation and submission information.
- All costs related to transportation of the owner's vehicle to and from the servicing dealership are processed outside of the warranty system.

NOTE: Dealers are authorized to perform the TSBs listed below. TSB repairs must be submitted on a regular warranty claim. Do not claim any TSB related repairs against either Emission Recall 04E14 or Safety Recall 04S26.

- TSB 04-25-06: Leakage From Transaxle Cooler Bypass Line
- TSB 04-26-09: Power Steering Fluid Leak at Cooler
- TSB 04-25-03: Rattle From Upper Steering Column

DEMONSTRATION / DELIVERY HOLD: Safety Recall 04S26 – Supplement #1
Certain 2005 Ford GT Vehicles
Suspension Control Arm Replacement

LABOR ALLOWANCES

Description	Labor Operation	Labor Time
Replace upper and lower suspension control arms at each wheel.	MT04S26B	Actual Time

PARTS REQUIREMENTS / ORDERING INFORMATION

Part Number	Description	Quantity
4G7Z-3084-B	Suspension Repair Kit	1

The DOR/COR for this program is 50343. This number identifies parts for this program.

- **SOLD UNITS:** Ford SVT will coordinate scheduling service appointments between the owner and the dealer. Parts will be shipped automatically to coincide with the scheduled repair date.
- **IN-STOCK UNITS:** As part availability increases, the parts will automatically be shipped to dealers based on the production date of the affected vehicles. The earliest built vehicles will be the first to receive parts. Prior to shipping parts for in-stock vehicles, Ford will contact the servicing dealer to provide advance notice of parts shipment and to confirm that the vehicle is still in the dealer's possession.

DEALER PRICE

For latest prices, refer to DOES II.

PARTS RETENTION AND RETURN

All affected GT Suspension Control Arms must be returned to the Ford Warranty Parts Analysis Center (WPAC). Refer to your daily PEARS (Parts Entry And Return System) register for part disposition and return instructions.

NOTE: If part disposition indicates anything other than "FCS-700 Tag Return", contact the Warranty Parts Analysis Center hotline at 1-800-416-9772 to get instructions on returning parts without a 700 tag attached.

Follow the provisions of the Warranty and Policy Manual for "Parts Retention and Return Procedures."

EXCESS STOCK RETURN

Excess stock returned for credit must have been purchased from Ford Customer Service Division in accordance with Policy Procedure Bulletin 4000.

DEMONSTRATION / DELIVERY HOLD: Safety Recall 04S26 – Supplement #1
Certain 2005 Ford GT Vehicles
Suspension Control Arm Replacement

This is a list of parts contained in the Control Arm Kit.	Description	Quantity	Service Number
	Right front lower control arm	1	4G7Z-3078-B
	Left front lower control arm	1	4G7Z-3079-B
	Rear lower control arm	2	4G7Z-5A649-B
	Upper control arm	4	4G7Z-3082-B
	Front LCA shim; -1 mm	4	4G7Z-3A182-AB
	Front LCA shim; nominal	4	4G7Z-3A182-BB
	Front LCA shim; +1 mm	4	4G7Z-3A182-CA
	Rear UCA shim; -1 mm	4	4G7Z-5A802-AB
	Rear UCA shim; nominal	4	4G7Z-5A802-BB
	Rear UCA shim; +1 mm	4	4G7Z-5A802-CA
	Front LCA-to-knuckle ball joint nut	2	W708503-S441
	UCA-to-knuckle ball joint nut	4	W520214-S440
	Rear LCA-to-knuckle nut	2	W705518-S427
	Rear damper-to-knuckle nut	2	W705518-S427
	ABS sensor harness clips	8	W702320-S300
	Half-shaft-to-hub nut	2	N808405-S100A
Front stabilizer bar link-to-knuckle nut	2	W520213-S427	
Rear stabilizer bar link-to-bar nut	2	W520213-S427	
Toe link-to-knuckle nut	2	W520213-S427	

This list of part numbers is provided FOR REFERENCE ONLY in the event that a fastener is lost, damaged, or broken during the repair.	Description	Service Number
	LCA-to-frame bolt	W710154-S438
	LCA-to-frame washer	W710548-S439
	UCA-to-frame bolt	W710200-S438
	UCA-to-frame washer	W710547-S439
	Front damper-to-LCA bolt	W500769-S301
	Damper-to-frame bolts	W710155-S438
	Damper-to-frame washers	W710549-S439
	Rear LCA-to-knuckle bolt	W705516-S426
	Rear damper-to-knuckle bolt	W500572-S426
	Toe link-to-knuckle bolt	W702042-S309
	Brake caliper-to-knuckle bolt	4G7Z-2W303-BA
	Parking brake caliper-to-knuckle bolts	2W9Z-2W303-CA
	Rotor-to-hub bolt	W505742-S301
Splash Shield Push Pin	W705589-S300	

CERTAIN 2005 MODEL YEAR FORD GT VEHICLES — CONTROL ARM REPLACEMENT

OVERVIEW

This program involves replacing all eight (8) suspension control arms (4 uppers and 4 lowers) on the affected vehicles. These instructions have been developed in conjunction with a Fordstar Training video that will be mailed to your dealership. We encourage you to watch the video before performing this repair.

A Master Compliance Inspection Report (MCIR) is located at the end of this Attachment III. This report documents that each fastener has been tightened to the proper torque specification by the technician and then checked by another individual. A paint stripe is to be neatly applied to each fastener after it has been tightened to specification, then that fastener is to be checked off as having been tightened on the MCIR. An inspector, or a technician other than the one who performed the repairs, must then verify all torque values (except wheel lug nuts) set by the servicing technician by inspecting for the presence of an unbroken paint stripe. It will be easiest if the wheels are left off after control arm replacement and then all torque values are inspected at each corner of the vehicle at one time. The Master Compliance Inspection Report must remain in the service record at the servicing dealership. See Figure 1 for an example of the paint stripe and how it is to be applied.

NOTE: Since both yellow and red paint stripes are applied to fasteners during factory assembly, use a different color (white or green possibly) to distinguish your paint stripes from factory-applied paint stripes.

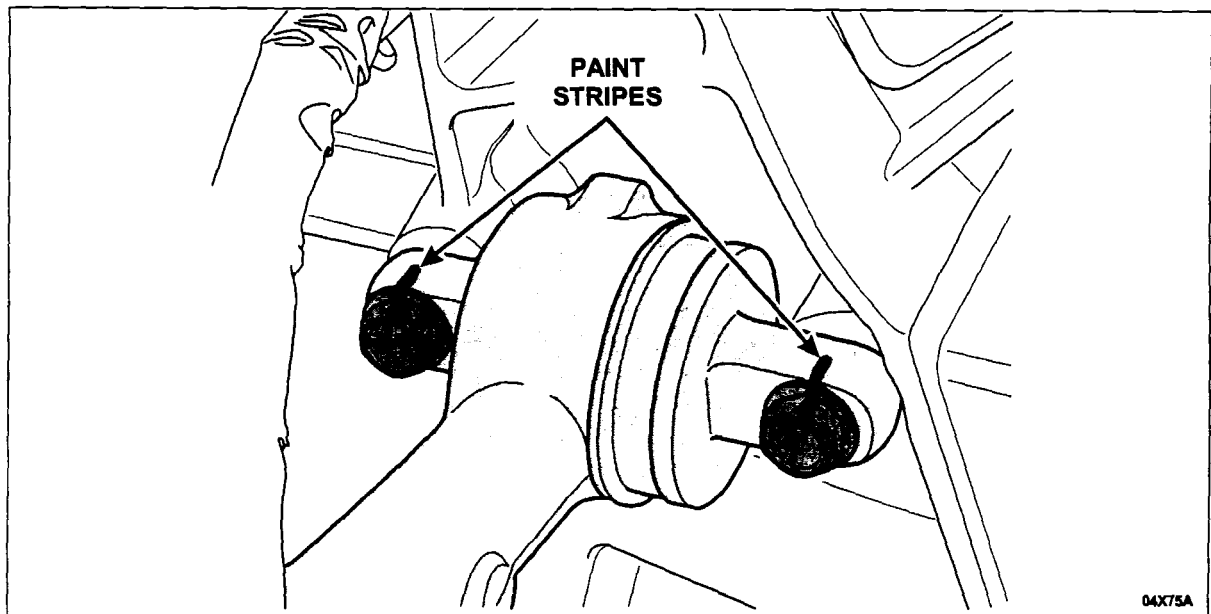

FIGURE 1



CAUTION: Suspension fasteners are critical parts because they affect performance of vital components and systems and their failure can result in major service expense. A *new* part with the same part number must be installed, if replacement is necessary. Do not use a part of lesser quality or substitute design. Torque values must be used as specified during reassembly to make sure of correct retention of these parts. Never attempt to heat, quench or straighten any suspension part. Install a *new* part.

CAUTION: Do NOT remove splashshields or belly pans. Removal is not required to perform this repair. If splashshield is removed or partially pulled back, use nylon push pin (W705589-S300) to re-attach to frame.

Before beginning this repair, be sure to have the following required tools, equipment and materials:

- Two-post hoist
- Alignment rack
- Metric wrenches and sockets
- Metric hex keys
- Torque wrench
- Pry bar
- Metal Brake Parts Cleaner PM-4 or equivalent
- Penetrating and Lock Lubricant XL-1
- High Temperature Nickel Anti-Seize Lubricant XL-2
- High Strength Threadlock 262 (TA-26)
- Paint pen (any color other than red or yellow)



PREPARING VEHICLE FOR HOISTING

1. Position a 2" x 12" piece of wood approximately 18" long at each wheel location where the vehicle will sit within the hoist.
2. Drive the Ford GT onto wood pieces.
3. To avoid damage or marring of the underbody shields, position wood blocks measuring 3- $\frac{1}{2}$ " x 2" x $\frac{3}{4}$ " on the rear hoist pads and either thick cloths, rubber pads or heavy cardboard on the front hoist pads. Be sure to properly position the hoist pads as indicated. See Figure 2.

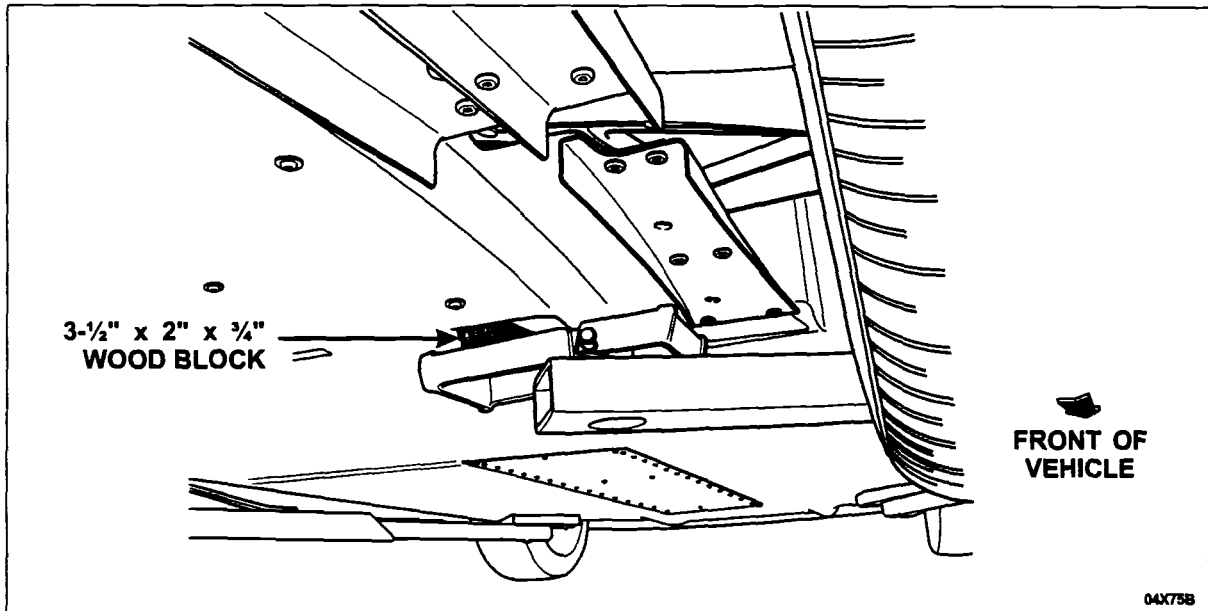

FIGURE 2

4. NOTE: If the vehicle is not equipped with standard wheels, proceed to Step 5.

Remove the wheel center caps as follows:

CAUTION: To avoid damage to the center cap, place facing up when removed.

- Rotate the center cap counterclockwise to the stop.
- Push and rotate the center cap counterclockwise to the second stop and remove.
- Rotate the center cap insert counterclockwise and remove it, then place it facing up to avoid damaging the finished surface.
- Proceed to Step 5.



5. **CAUTION:** Do not use heat to loosen a seized wheel nut. Heat can damage the wheel and wheel bearings.

CAUTION: Do not use impact tools to loosen or tighten the wheel nuts as they can damage the chrome exterior of the nuts. Use hand tools to remove, replace and final torque the wheel nuts. Also, use extreme caution when installing the wheel nuts as sockets can cause scratches on the surface of the wheels.

Loosen, but do not remove, all wheel nuts.

6. Loosen, but do not remove, both hub nuts.

LIFTING POINTS — TWO-POST LIFT

CAUTION: Do not allow the lift adapters to contact the steering linkage, suspension arms, front cross braces, stabilizer bar or to compress the lower suspension arm or stabilizer bar insulator. Damage to the suspension, exhaust and steering linkage components may occur if care is not exercised when positioning the lift adapters prior to lifting the vehicle.

CAUTION: Under no circumstances should the vehicle be lifted by the front control arms, front cross braces, rear control arms or at any point other than the designated lift points. Severe damage to the vehicle could result.

NOTE: Adapters may be necessary to clear vehicle components to lift the vehicle safely. The adapters must be placed at the designated contact points. Position the adapters so they are centered on the adapter contact area.

NOTE: Either front lifting point is acceptable to use.

1. Open rear deck lid.
2. With the vehicle in NEUTRAL, lift the vehicle at the applicable lift points as shown in the figure. See Figure 3.

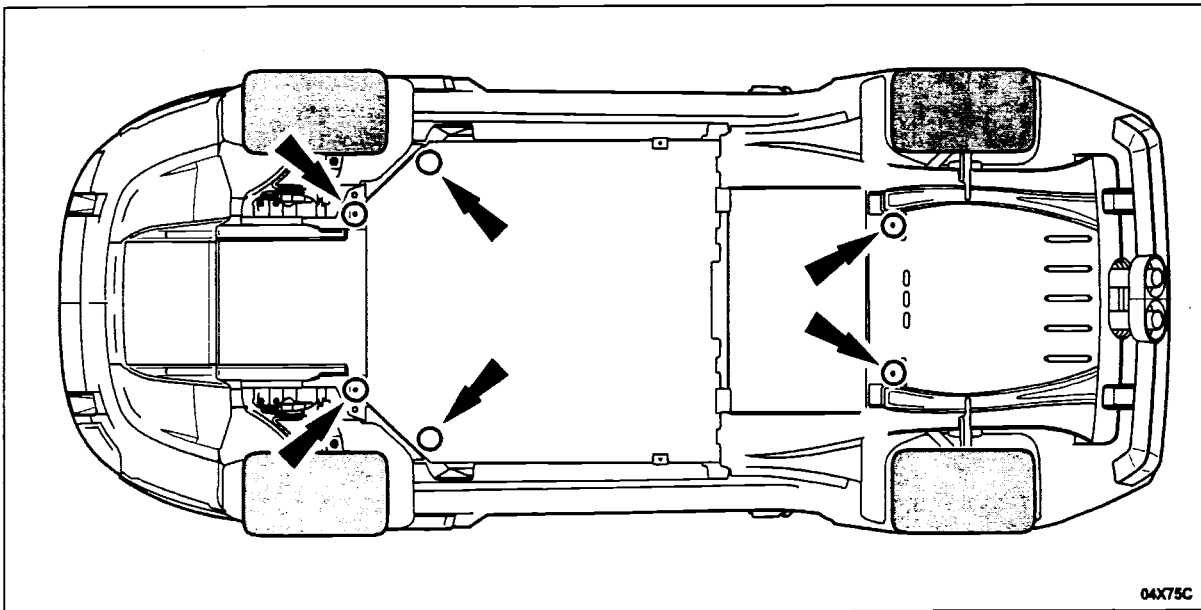

FIGURE 3



WHEEL AND TIRE ASSEMBLY — REMOVAL

1. **CAUTION:** Do not use impact tools to loosen or tighten the wheel nuts as they can damage the chrome exterior of the nuts. Use hand tools to remove, replace and final torque the wheel nuts. Also, use extreme caution when installing the wheel nuts as sockets can cause scratches on the surface of the wheels.
2. Remove the wheel nuts.

CAUTION: Do not use heat to loosen a seized wheel because heat can shorten the life of the wheel and damage the wheel bearings. If the wheel cannot be removed by hand, use a wheel puller to remove the seized wheel.

Remove all four (4) wheel and tire assemblies.

FRONT LOWER CONTROL ARM – REMOVAL

1. **CAUTION:** Do not allow the disc brake caliper to hang from the brake hose. Support the caliper with mechanic's wire.

CAUTION: Protect calipers from contacting other components as painted calipers can chip or scratch.

Remove brake caliper-to-knuckle bolts, then pull the caliper off the knuckle and support with mechanic's wire or a bungee cord.

2. Remove the brake disc-to-hub bolts, then remove the disc from the hub.

3. **CAUTION:** Protect control arms and other components with rubber or cloth prior to using pry bar.

Push the lower control arm down to remove the load on the upper shock absorber and spring assembly bolts, then remove the upper shock absorber and spring assembly bolts and washers. See Figure 4.

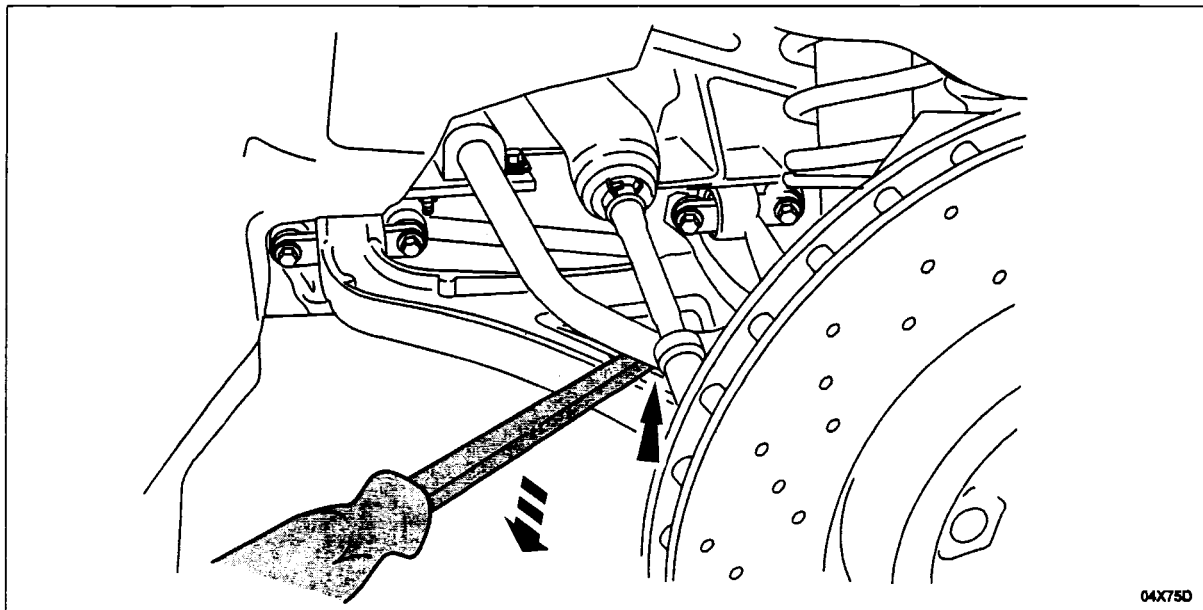

FIGURE 4



4. Remove the lower shock absorber and spring assembly bolt, then remove the shock absorber and spring assembly from the vehicle. See Figure 5.

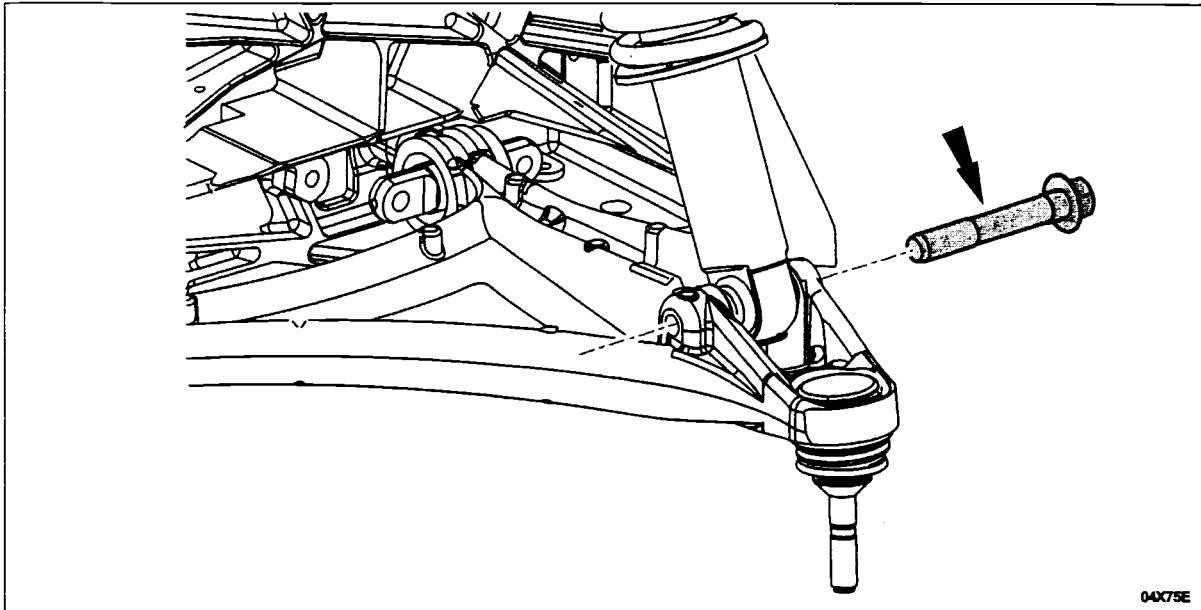

FIGURE 5

5. Disconnect stabilizer bar link from the knuckle by holding the internal hex holding feature on the stud with a metric hex key (Allen wrench), then remove the front stabilizer bar link-to-knuckle nut. Discard the nut after removal.
6. Remove the stabilizer bar link ball stud from knuckle.



7. While holding the internal hex holding feature on the stud with a metric hex key (Allen wrench), remove and discard the lower control arm-to-knuckle ball stud nut. See Figure 6.

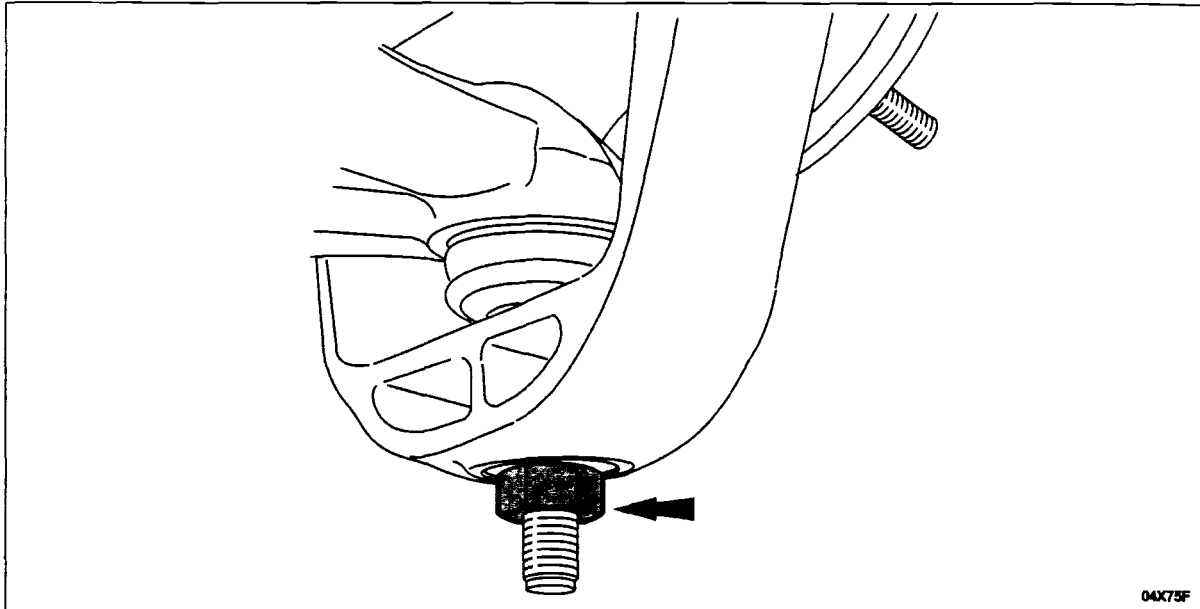

FIGURE 6

8. Remove the ABS sensor harness from the two (2) clips in the lower control arm. Remove and discard the two (2) clips.



9. **CAUTION:** Note the alignment shim colors and positions before removing the lower control arm-to-frame bolts. Changing the original position of the alignment shims changes the camber and caster angles.

CAUTION: Protect the control arms and other components with rubber or cloth prior to using pry bar.

While pushing down on the lower control arm, remove the two (2) inner lower control arm-to-frame bolts and washers. Then, release the arm and remove the two (2) outer bolts and washers and remove the lower control arm from the vehicle. See Figure 7.

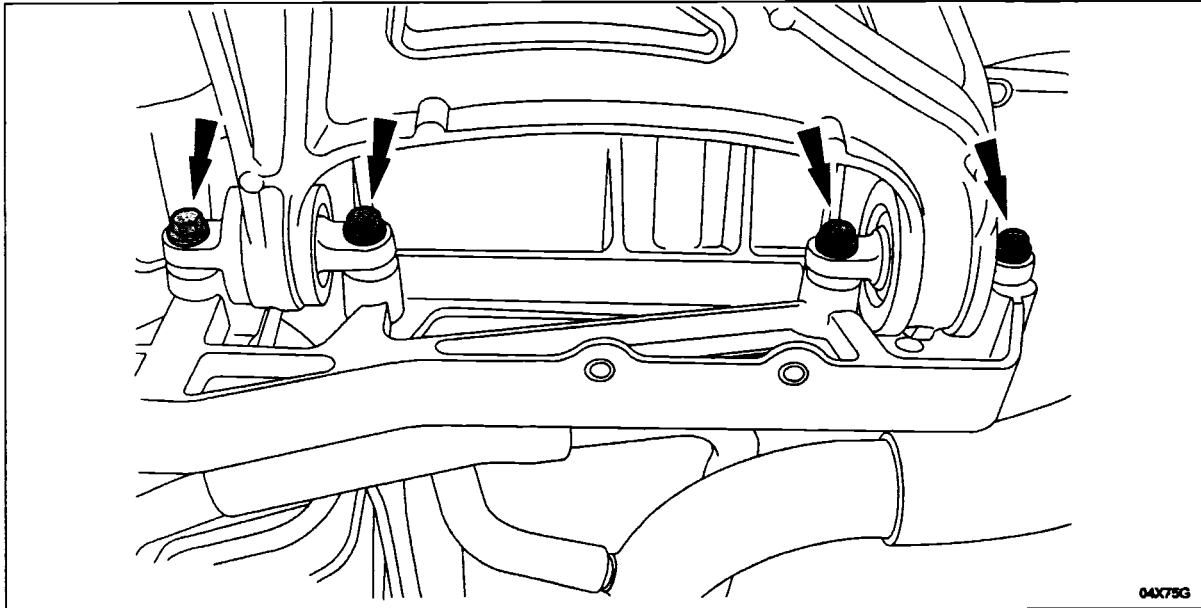

FIGURE 7



FRONT LOWER CONTROL ARM — INSTALLATION

1. Check the lower control arm-to-frame bolt holes for cleanliness. If necessary, use an M10 X 1.50 tap to chase the threads prior to installing the bolts into the frame.
2. Position the **new** lower control arm ball stud into the knuckle.
3. Install the two (2) **outer** lower control arm-to-frame bolts and washers with the removed alignment shims in their original locations. Be sure to place the shims between the arm and the frame (**NOT** between the bolt head and the arm).
4. **CAUTION: Protect the control arms and other components with rubber or cloth prior to using pry bar.**

While pushing down on the lower control arm, install the two (2) **inner** lower control arm-to-frame bolts and washers with the removed alignment shim in their original locations. Be sure to place the shims between the arm and the frame (**NOT** between the bolt head and the arm).

5. Tighten the four (4) lower control arm-to-frame bolts to 55 Nm (41 lb-ft). Apply a paint stripe to each of the four (4) bolts then check off the appropriate box on the Master Compliance Inspection Report.
6. Install a **new** lower control arm-to-knuckle ball stud nut (W708503-S441) while holding the internal hex holding feature on the stud with a metric hex key (Allen wrench). Tighten the nut to 150 Nm (111 lb-ft). Then, apply a paint stripe on the nut and check the appropriate box on the Master Compliance Inspection Report.
7. **CAUTION: Due to the extremely low ground clearance of the vehicle, it is essential that the ABS sensor wire not be allowed to hang below the control arm.**

Install the **new** ABS sensor harness clips (W702320-S300) into the lower control arm. Secure the ABS sensor harness grommets in the clips so that harness between clips is as short as possible. See Figure 8.

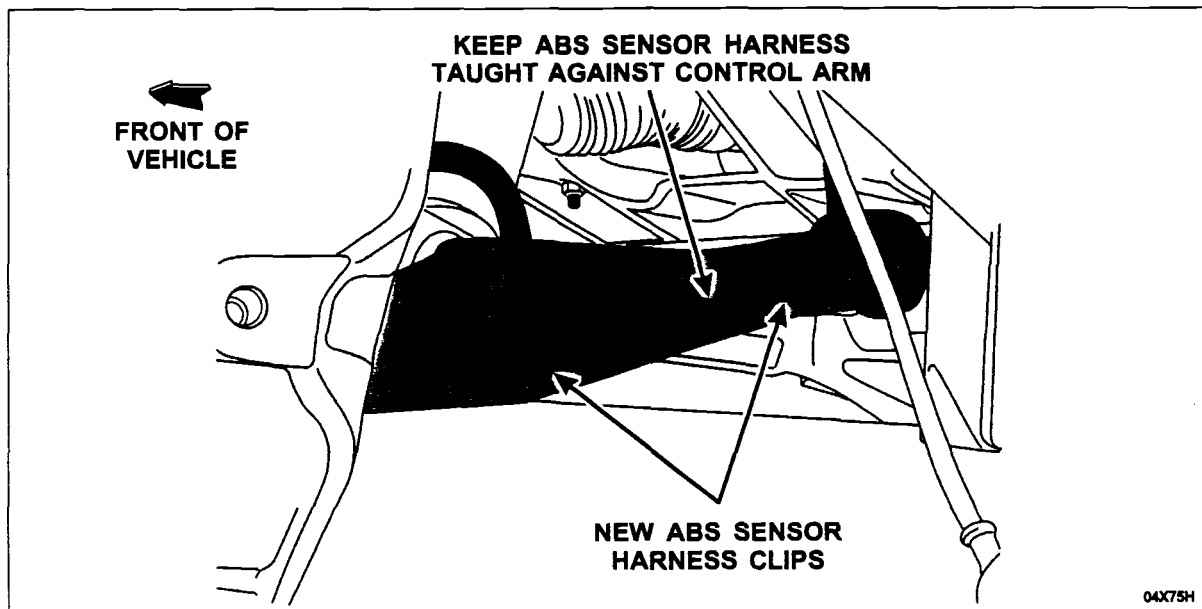

FIGURE 8



FRONT UPPER CONTROL ARM — REMOVAL

1. Loosen the upper control arm-to-knuckle ball stud nut. See Figure 9.

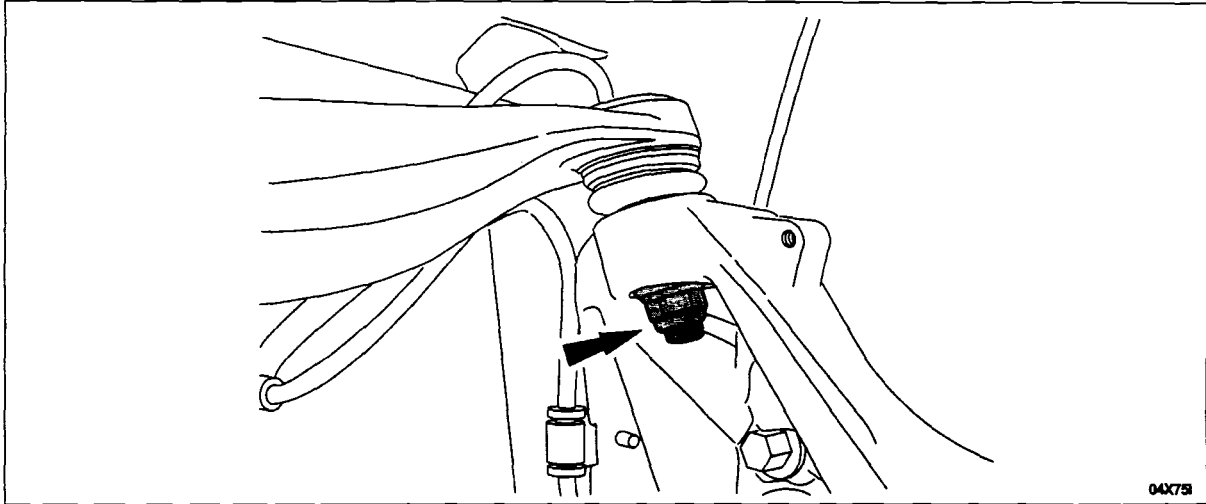

FIGURE 9

2. Remove the two (2) inner upper control arm-to-frame bolts and washers.
3. Remove and discard the upper control arm-to-knuckle ball stud nut.
4. Remove the two (2) outer upper control arm-to-frame bolts and washers. See Figure 10.

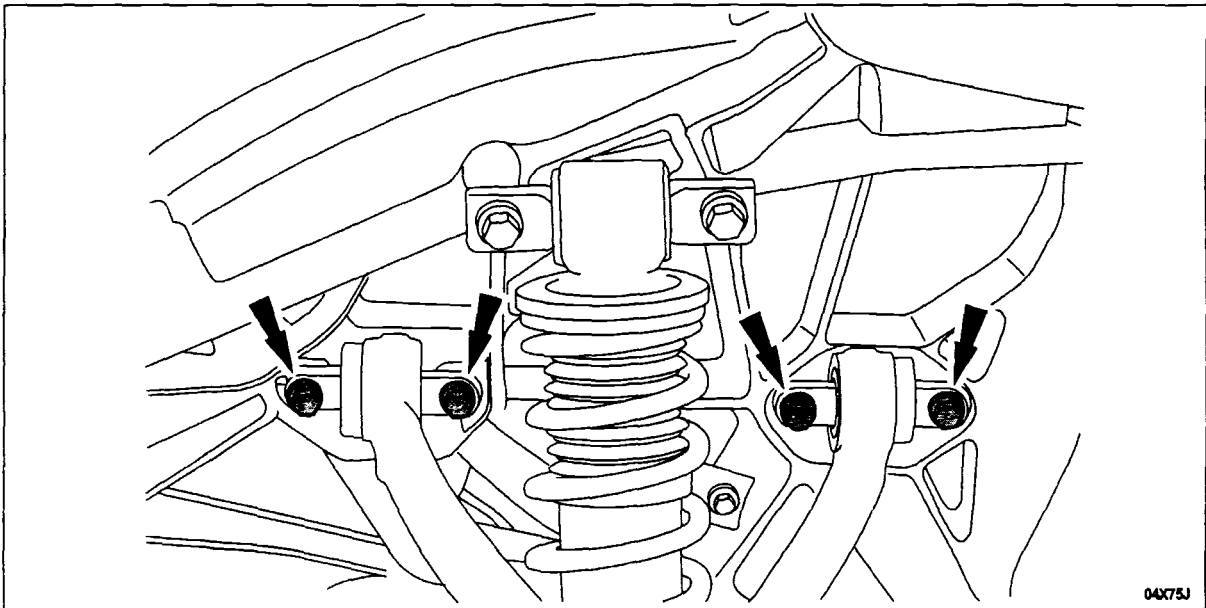

FIGURE 10

5. Remove the upper control arm.



FRONT UPPER CONTROL ARM — INSTALLATION

1. Check the upper control-arm-to-frame bolt holes for cleanliness. If necessary, use an M8 X 1.25 tap to chase the threads prior to installing the bolts into the frame.
2. Position the *new* upper control arm.
3. Install the *new* cone washer supplied with the upper control arm onto the ball stud and position it into knuckle.
4. Install the two (2) outer upper control arm-to-frame bolts and washers.
5. Install a *new* upper control arm-to-knuckle ball stud nut (W520214-S440).
6. Install the two (2) inner upper control arm-to-frame bolts and washers.
7. **CAUTION: It is crucial that the control arm be positioned as far rearward as possible rearward when tightening the bolts. This is necessary to maintain proper chassis and wheel alignment.**

Push the upper control arm as far rearward in vehicle as possible, then tighten the four (4) upper control arm-to-frame bolts to 30 Nm (22 lb-ft). Then, apply a paint stripe to the bolts and check the appropriate box on the Master Compliance Inspection Report.

8. Tighten the upper control arm-to-knuckle ball stud nut to 90 Nm (66 lb-ft), then apply a paint stripe to the nut and check the appropriate box on the Master Compliance Inspection Report.
9. Position the stabilizer bar link ball stud into knuckle and install a *new* stabilizer bar link-to-knuckle nut (W520213-S427). Tighten the nut to 55 Nm (41 lb-ft), then apply a paint stripe to the nut and check the appropriate box on the Master Compliance Inspection Report.
10. Check the shock absorber upper mounting bolt-to-frame bolt holes for cleanliness. If necessary, use an M12 X 1.75 tap to chase the threads prior to installing the bolts into the frame.
11. Position the shock absorber and spring assembly in the vehicle and install the lower shock absorber and spring assembly bolt.



12. **CAUTION: Protect the control arms and other components with rubber or cloth prior to using pry bar.**

Push the lower control arm down to align the upper shock absorber holes to the frame holes then install upper shock absorber and spring assembly bolts and washers. See Figure 11.

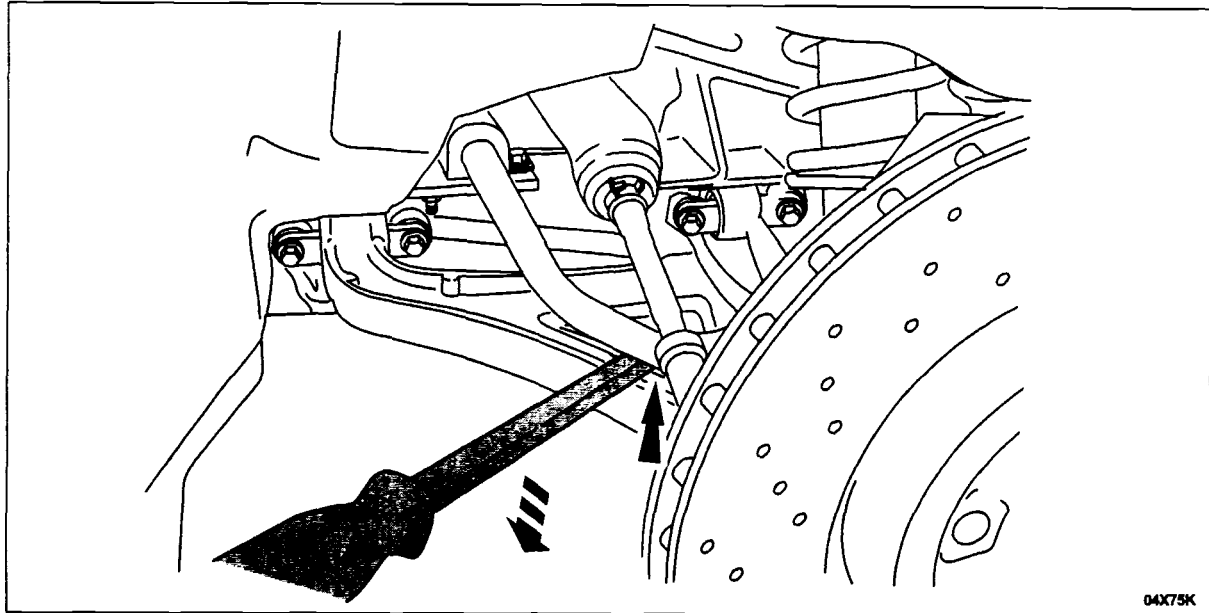

FIGURE 11

13. Tighten the lower shock absorber and spring assembly bolt to 175 Nm (129 lb-ft).
14. Tighten the upper shock absorber and spring assembly bolts to 103 Nm (76 lb-ft).
15. Apply a paint stripe the shock absorber mounting bolts and check the appropriate box on the Master Compliance Inspection Report.
16. Apply a thin, light coat of Motorcraft High Temperature Nickel Anti-Seize Lubricant, part number XL-2, on high surfaces of the hub flange.
17. Install the brake disc onto the hub.
18. Install the brake disc-to-hub bolts. Tighten the bolts to 28 Nm (21 lb-ft). Apply a paint stripe to the bolts and check the appropriate box on the Master Compliance Inspection Report.
19. Clean the mounting surfaces of the brake caliper and knuckle with Motorcraft Metal Brake Parts Cleaner, part number PM-4.
20. Install the brake caliper onto the knuckle.
21. Install the brake caliper-to-knuckle bolts. Tighten the bolts to 100 Nm (74 lb-ft), then apply a paint stripe to the bolts and check the appropriate box on the Master Compliance Inspection Report.



REAR LOWER AND UPPER CONTROL ARM — REMOVAL

1. Remove and discard the outer halfshaft-to-hub nut.
2. **CAUTION: Do not allow the disc brake caliper to hang from the brake hose. Support the caliper with mechanic's wire.**

CAUTION: Protect the calipers from contacting other components as painted calipers can chip or scratch.

Remove brake caliper-to-knuckle bolts, then pull the caliper off the knuckle and support with mechanic's wire or a bungee cord. See Figure 12.

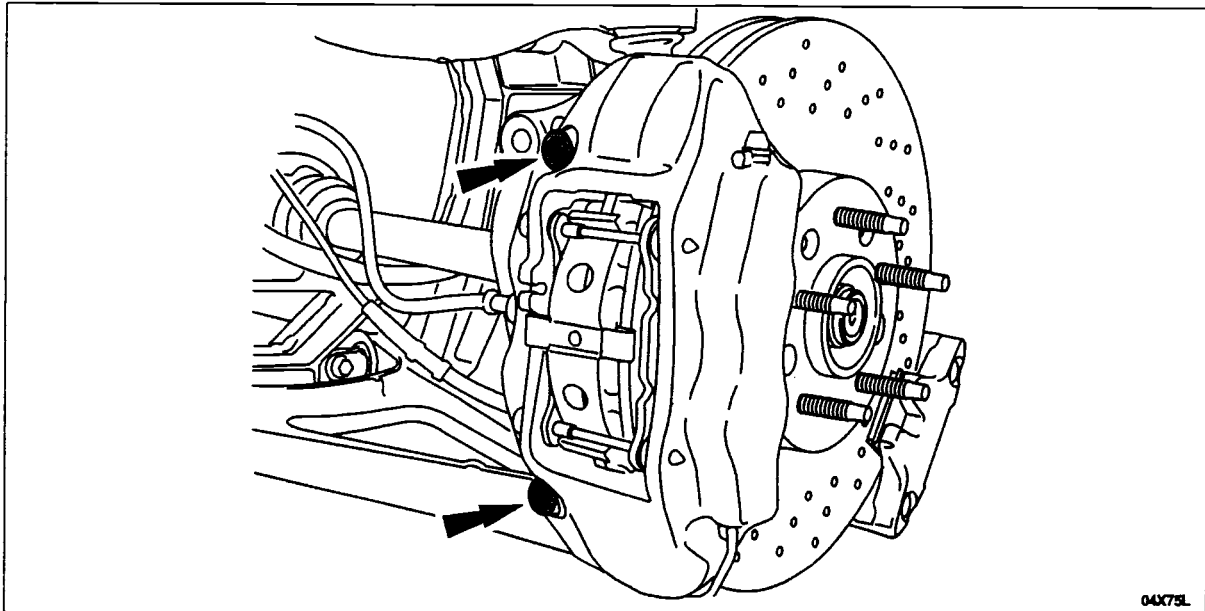

FIGURE 12

04X75L



3. Remove parking brake caliper-to-knuckle bolts, then pull the caliper off the knuckle and support with mechanic's wire or a bungee cord. See Figure 13.

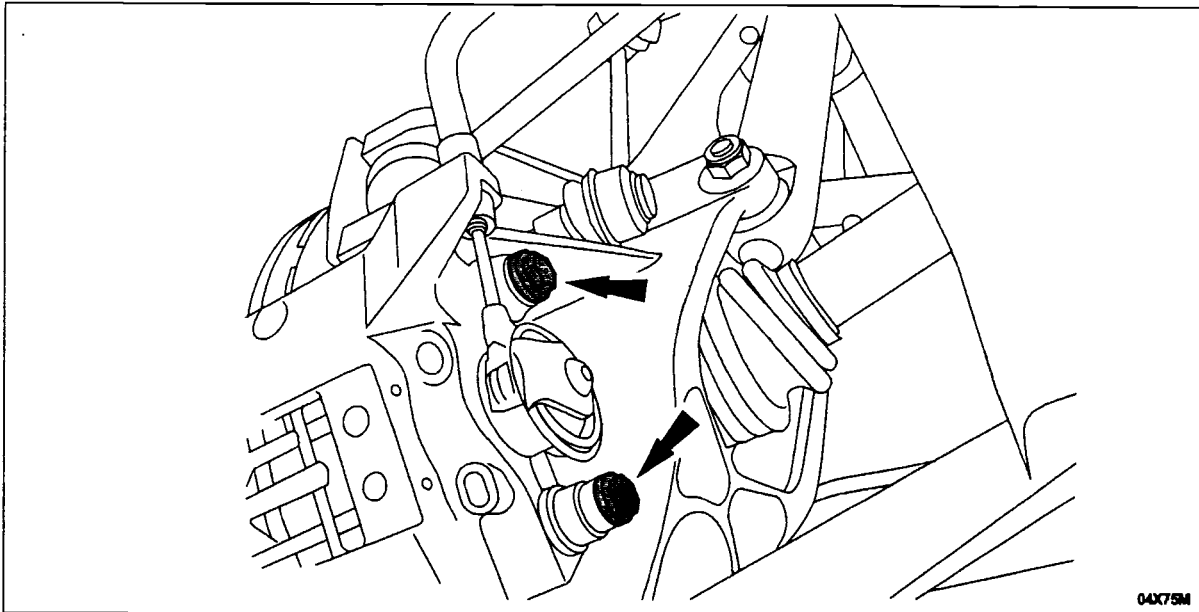

FIGURE 13

4. **CAUTION: Protect control arms and other components with rubber or cloth prior to using pry bar.**

Push the lower control arm down to remove the load on the upper shock absorber and spring assembly bolts. See Figure 14.

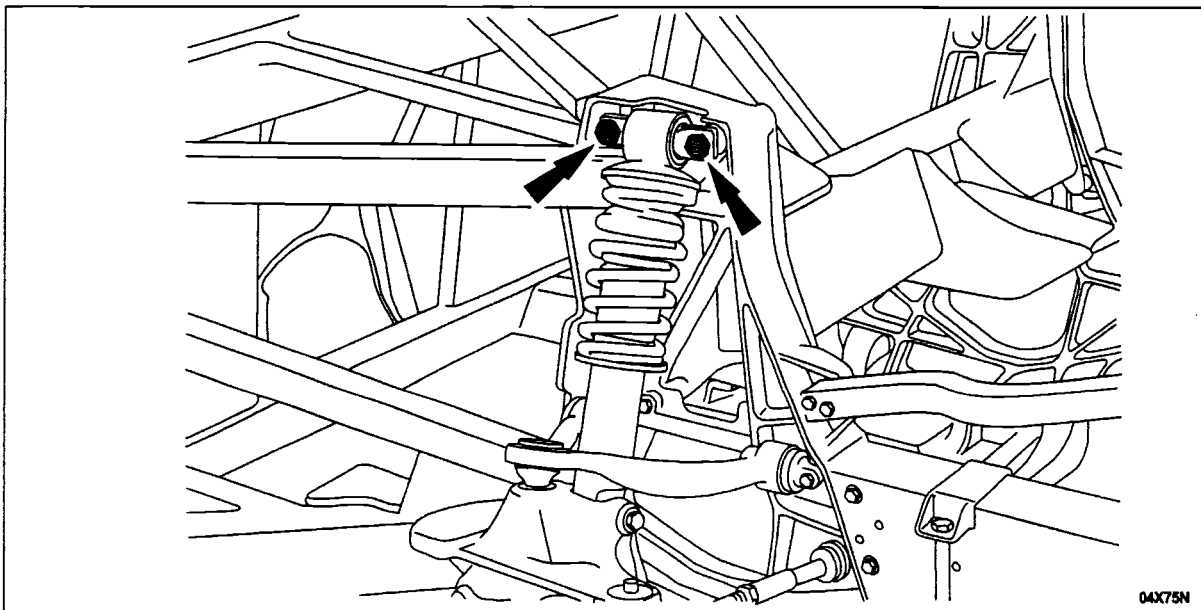

FIGURE 14



5. Remove the upper shock absorber and spring assembly bolts and washers.
6. Remove the lower shock absorber and spring assembly nut and bolt, then remove the shock absorber and spring assembly from the vehicle. Discard the nut only. See Figure 15.

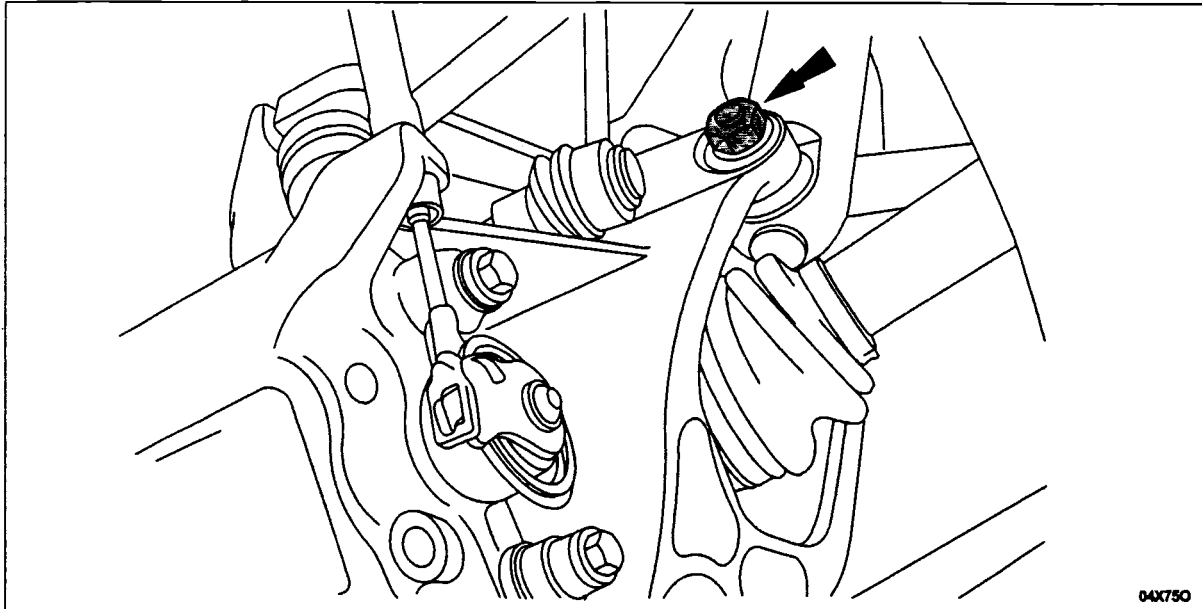

FIGURE 15

7. **NOTE:** It is not necessary to remove the splash shield to gain access to the ABS connector.
By gaining access through the engine compartment, disconnect the ABS sensor harness connector from the vehicle harness.
8. Remove the ABS sensor harness from the two (2) clips in the lower control arm. Remove and discard the two (2) clips.
9. While holding the internal hex holding feature on the stud with a metric hex key (Allen wrench), remove and discard the stabilizer link-to-bar nut.
10. Remove the stabilizer bar link ball stud from the stabilizer bar.



11. **CAUTION:** Note the shim colors and positions before removing the toe link. Changing the original position of the shims changes the bump steer settings.

Remove the outer toe link nut and bolt, then remove the toe link from the wheel knuckle.
Discard the nut only.

12. Remove the lower control arm-to-knuckle nut and bolt. Discard the nut only. See Figure 16.

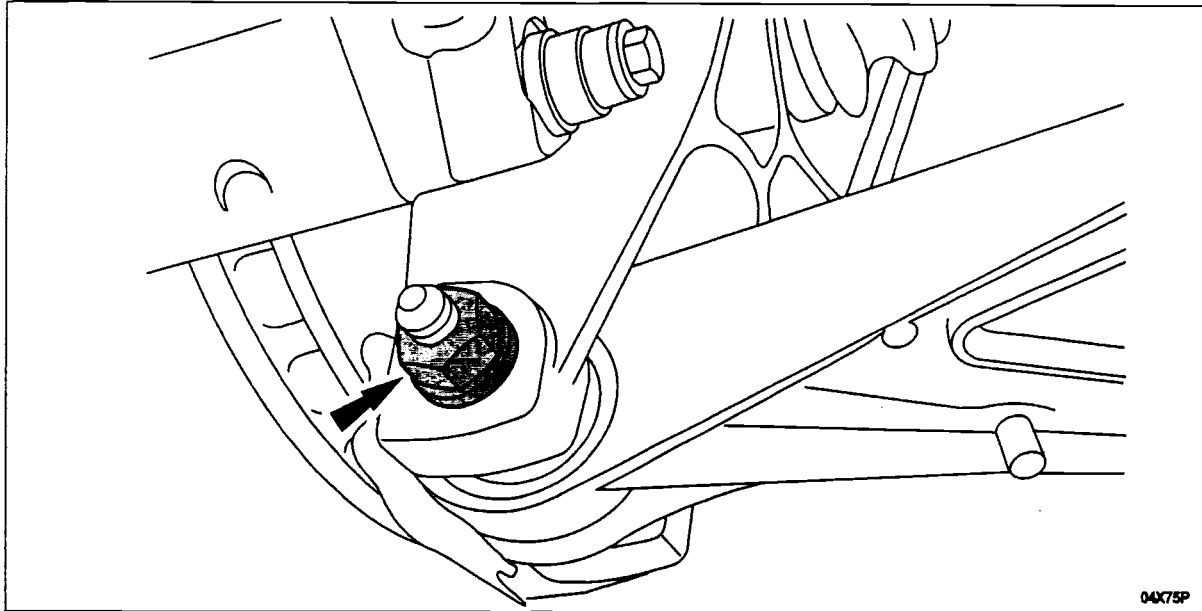

FIGURE 16

13. **CAUTION:** Note the alignment shim colors and positions before removing the upper control arm-to-frame bolts. Changing the original position of the alignment shims changes the camber and caster angles.

Remove the two (2) inner, then the two (2) outer upper control arm-to-frame bolts and washers and remove the control arm and wheel knuckle from the vehicle.

14. **CAUTION:** Protect the control arms and other components with rubber or cloth prior to using pry bar.

While pushing down on the lower control arm, remove the two (2) inner lower control arm-to-frame bolts and washers.



15. Release the arm and remove the two (2) outer lower control arm-to-frame bolts and washers, then remove the control arm from the vehicle. See Figure 17.

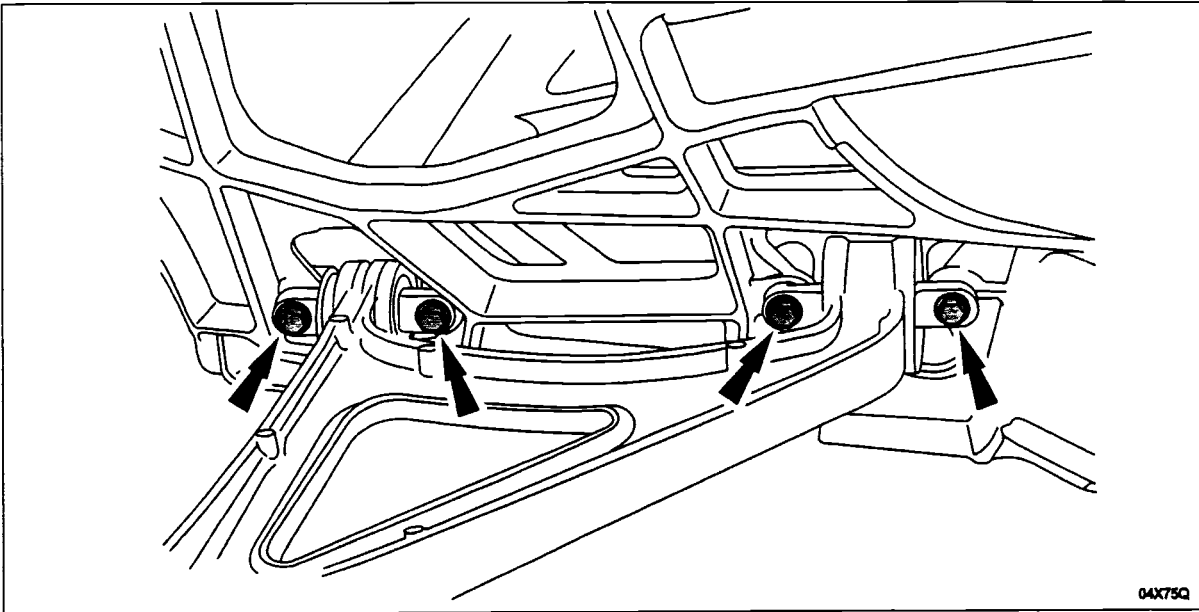

FIGURE 17

16. Remove and discard the upper control arm-to-knuckle ball stud nut. See Figure 18.

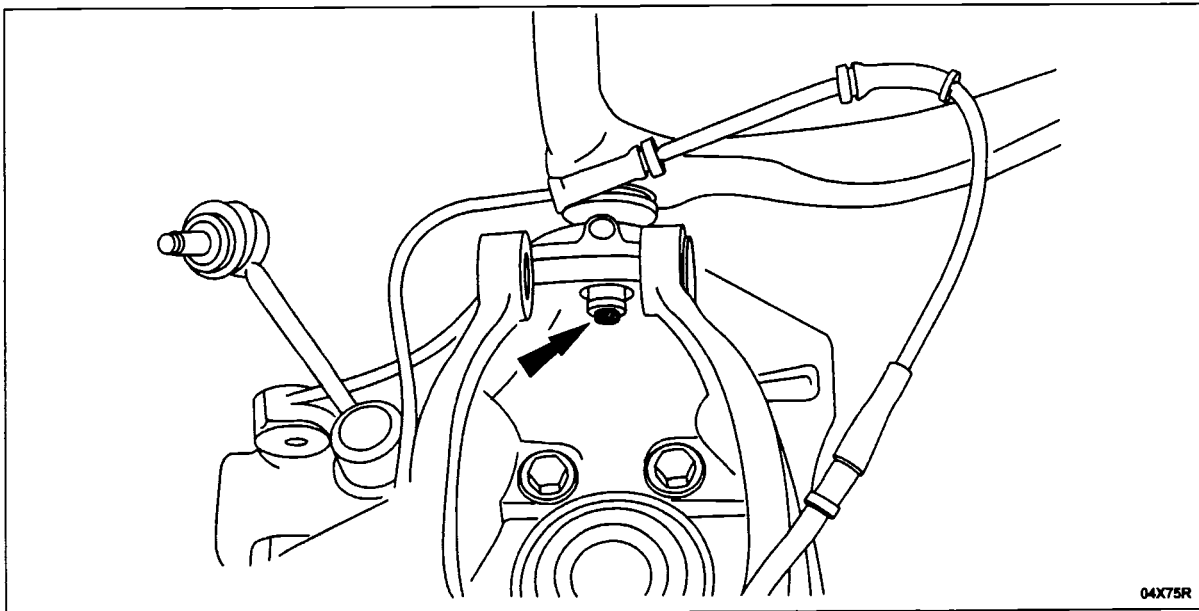

FIGURE 18



REAR LOWER AND UPPER CONTROL ARM – INSTALLATION

1. Install **new** cone washer supplied with the upper control arm onto the ball stud and position into knuckle.
2. Install a **new** upper control arm-to-knuckle ball joint stud nut (W520214-S440). Tighten the nut to 90 Nm (66 lb-ft), then apply a paint stripe to the nut and check the appropriate box on the Master Compliance Inspection Report.
3. Check the lower control arm-to-frame bolt holes for cleanliness. If necessary, use an M10 X 1.50 tap to chase threads prior to installing the bolts into the frame.
4. Position the lower control arm to the frame and install the two (2) **outer** lower control arm-to-frame bolts and washers.
5. **CAUTION: Protect the control arms and other components with rubber or cloth prior to using pry bar.**
While pushing down on the lower control arm, install the two (2) **inner** lower control arm-to-frame bolts and washers.
6. Tighten the four (4) lower control arm-to-frame bolts to 55 Nm (41 lb-ft), then apply a paint stripe to the bolts and check the appropriate box on the Master Compliance Inspection Report.
7. Check the upper control arm-to-frame bolt holes for cleanliness. If necessary, use an M8 X 1.25 tap to chase threads prior to installing the bolts into the frame.
8. Position the **new** upper control arm.
9. Install the two (2) outer upper control arm-to-frame bolts and washers with the removed alignment shims in their original locations. Be sure to place the shims between the arm and the frame (**NOT** between the bolt head the arm).
10. **CAUTION: Protect the control arms and other components with rubber or cloth prior to using pry bar.**
Using the original alignment shim colors and positions, push down on the upper control arm and install the two (2) inner upper control arm-to-frame bolts and washers.
11. **CAUTION: It is crucial that the control arm be positioned as far rearward as possible when tightening the bolts. This is necessary to maintain proper chassis and wheel alignment.**
Push the upper control arm as far rearward in vehicle as possible, then tighten the four (4) upper control arm-to-frame bolts to 30 Nm (22 lb-ft). Then, apply a paint stripe to the bolts and check the appropriate box on the Master Compliance Inspection Report.
12. Attach **new** ABS sensor harness clips (W702320-S300) to lower control arm and install harness into clips.
13. **NOTE:** It is not necessary to remove the splash shield to gain access to the ABS connector.
Connect the ABS sensor harness connector to the vehicle harness.
14. Using a **new** nut (W705518-S427), attach the lower control arm to the knuckle. While holding the bolt with a suitable wrench, tighten the nut to 150 Nm (111 lb-ft), then apply a paint stripe to both the nut and the bolt and check the appropriate box on the Master Compliance Inspection Report.



15. Position the toe link into the knuckle with the removed shims in their original locations.
16. Install the toe link-to-knuckle bolt and a **new** nut (W520213-S427). While holding the bolt with a suitable wrench, tighten the nut to 55 Nm (41 lb-ft). Apply a paint stripe to the nut and the bolt then check the appropriate box on the Master Compliance Inspection Report.
17. Position the stabilizer bar link ball stud into the stabilizer bar.
18. Install a **new** stabilizer link-to-bar nut (W520213-S427). Tighten the nut to 55 Nm (41 lb-ft), then apply a paint stripe to the nut and check the appropriate box on the Master Compliance Inspection Report.
19. Check shock absorber upper mounting bolt-to-frame bolt holes for cleanliness. If necessary, use an M12 X 1.75 tap to chase the threads prior to installing the bolts into frame.
20. Position the shock absorber and spring assembly, then install lower shock absorber and spring assembly bolt and a **new** nut (W705518-S427).
21. **CAUTION: Protect the control arms and other components with rubber or cloth prior to using pry bar.**

Using a pry bar, push the lower control arm down to align the upper shock absorber holes to the frame holes, then install upper shock absorber and spring assembly bolts and washers.
22. Tighten the lower shock absorber and spring assembly nut to 175 Nm (129 lb-ft).
23. Tighten the upper shock absorber and spring assembly bolts to 103 Nm (76 lb-ft).
24. Apply a paint stripe to the bolts and the nut, then check the appropriate box on the Master Compliance Inspection Report.
25. Clean mounting surfaces of parking brake caliper and knuckle with Motorcraft Metal Brake Parts Cleaner, part number PM-4.
26. Install the parking brake caliper onto the knuckle.
27. Apply Motorcraft High Strength Threadlock 262, part number TA-26 to the parking brake caliper-to-knuckle bolts and install into knuckle. Tighten the bolts to 74 Nm (52 lb-ft), then apply a paint stripe to the bolts and check the appropriate box on the Master Compliance Inspection Report.
28. Clean mounting surfaces of disc brake caliper and knuckle with Motorcraft Metal Brake Parts Cleaner, part number PM-4.
29. Install the disc brake caliper onto the knuckle.
30. Install disc brake caliper-to-knuckle bolts. Tighten the bolts to 100 Nm (74 lb-ft), then apply a paint stripe to the bolts and check the appropriate box on the Master Compliance Inspection Report.
31. Install a **new** outer halfshaft nut (N808405-S100A). It will be tightened to specification after the wheel and tire assemblies are reinstalled.



VEHICLE INSPECTION AFTER REPAIRS

This inspection is to be performed by an individual other than the technician who performed the repair. It is easiest to perform this inspection before the wheel and tire assemblies are reinstalled. After verifying torque values of fasteners, the inspector must sign off on the Master Compliance Inspection Report contained within this document.

1. Inspect the brake caliper hose to make sure proper routing.
2. Inspect the splash shields to make sure they were not removed during the service.
3. Verify all fasteners have a paint stripe indicating the technician tightened each one to the proper torque specification. As each fastener is inspected, check it off on the Master Compliance Inspection Report.

WHEEL AND TIRE ASSEMBLY – INSTALLATION

WARNING: BEFORE A WHEEL IS RE-INSTALLED, ALWAYS REMOVE ANY CORROSION, DIRT OR FOREIGN MATERIAL PRESENT ON THE MOUNTING SURFACES OF THE WHEEL AND THE SURFACE OF THE WHEEL HUB, BRAKE DRUM OR BRAKE DISC THAT CONTACTS THE WHEEL. INSTALLING WHEELS WITHOUT CORRECT METAL-TO-METAL CONTACT AT THE WHEEL MOUNTING SURFACES CAN CAUSE THE WHEEL NUTS TO LOOSEN AND THE WHEEL TO COME OFF WHILE THE VEHICLE IS IN MOTION, CAUSING LOSS OF CONTROL.

1. Position the wheel and tire assemblies on the vehicle.
2. **CAUTION: Do not use impact tools to install the wheel nuts as they can damage the chrome exterior of the nuts. Use hand tools to replace and final tighten the wheel nuts. Also, use extreme caution when installing the wheel nuts as sockets can cause scratches on the surface of the wheels.**

Install the wheel nuts hand tight.

3. Lower the vehicle off the hoist.
4. **CAUTION: Failure to tighten the wheel nuts in a star pattern can result in high brake disc runout, which may cause the development of brake roughness, shudder and/or vibration.**

Tighten the wheel nuts to 133 Nm (98 lb-ft) in a star pattern sequence.

5. Tighten the hub nuts to 350 Nm (258 lb-ft). Apply a paint stripe to the nuts and check the appropriate box on the Master Compliance Inspection Report.
6. **NOTE: Perform this step only if the vehicle is equipped with standard wheels.**

Install the center cap inserts on the wheel by rotating it clockwise. Then, install the center cap by pushing it inwards and rotating it clockwise to the stop.



WHEEL ALIGNMENT

ALIGNMENT SPECIFICATIONS			
Item	LH	RH	Total/Split
Thrust angle	—	—	0° ± 0.05°
Front			
Camber	-0.40° ± 0.30°	-0.40° ± 0.30°	0° ± 0.40°
Caster	5.0° ± 0.30°	5.0° ± 0.30°	0° ± 0.40°
Toe (positive value is toe-in, negative value is toe-out)	0.04° ± 0.05°	0.04° ± 0.05°	0.08° ± 0.10°
Rear			
Camber	-1.44° ± 0.30°	-1.44° ± 0.30°	0° ± 0.40°
Caster	—	—	—
Toe (positive value is toe-in, negative value is toe-out)	0.11° ± 0.05°	0.11° ± 0.05°	0.22° ± 0.10°

Alignment angles change with shim change (Note: Use only shims supplied with service kit)

Front Camber

Thicker shim -0.20°
Thinner shim +0.20°

Front Caster

Thicker shim -0.25°
Thinner shim +0.25°

Rear Camber

Thicker shim +0.15°
Thinner shim -0.15°

1. Prepare the vehicle for an alignment as follows:
 - Set tire pressures to 221 kPa (32 psi).
 - Fill the fuel tank with fuel.
 - Settle the suspension by carefully driving the vehicle approximately ¼ to ½ mile while performing a series of light braking and accelerations and left to right turns (slalom).



2. **CAUTION: Failure to use ramp extensions will cause damage to the front splitter.**

Position ramp extensions similar to those in the figure below to reduce the incline angle of the alignment rack ramps. See Figure 19.

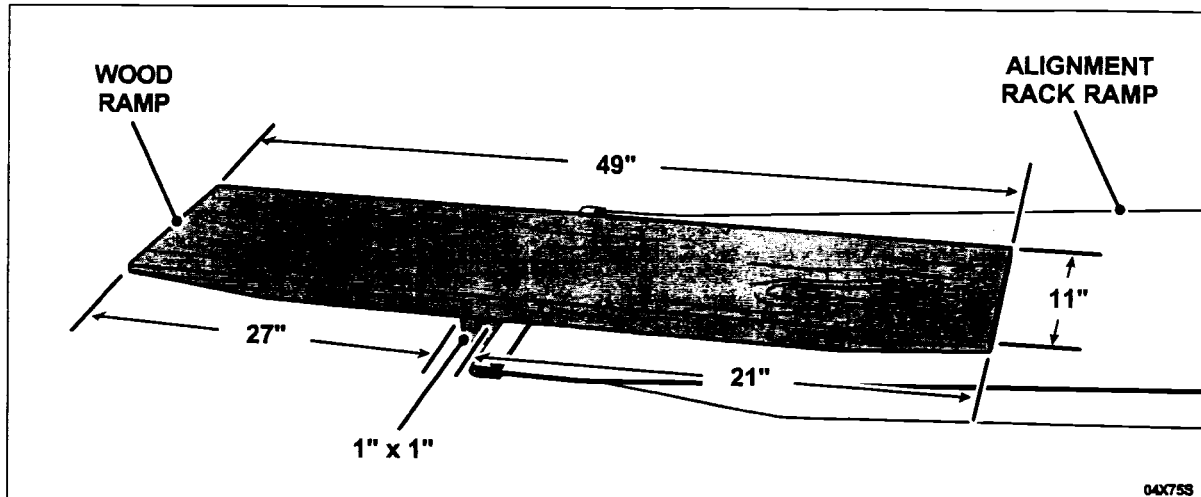

FIGURE 19

3. Drive Ford GT onto the alignment rack.
4. **CAUTION: Be sure to mount the alignment heads onto the wheels so as not to cause any damage (marring, scratches or nicks) to the wheels.**

Following manufacturer's instructions, mount the heads onto the wheels.

5. Check the vehicle alignment and adjust to specification as necessary.

Adjust rear toe as follows:

1. Hold the inner toe link and loosen the nut.
2. Rotate the inner toe link as necessary.
3. Hold the inner toe link and tighten the nut to 55 Nm (41 lb-ft), then apply a paint stripe onto the nut and check the appropriate box on the Master Compliance Inspection Report.
4. Recheck the toe setting. Re-adjust if necessary.



Adjust rear camber as follows:

1. Loosen the upper control arm-to-frame bolts.
2. To adjust rear camber, install the alignment shims between both bushings on the rear upper control arm and the frame. Loosen bolts as necessary, but replace only one shim at a time.
3. Tighten the bolts to 30 Nm (22 lb-ft), then apply a paint stripe to the bolts and check the appropriate box on the Master Compliance Inspection Report. See Figure 20.

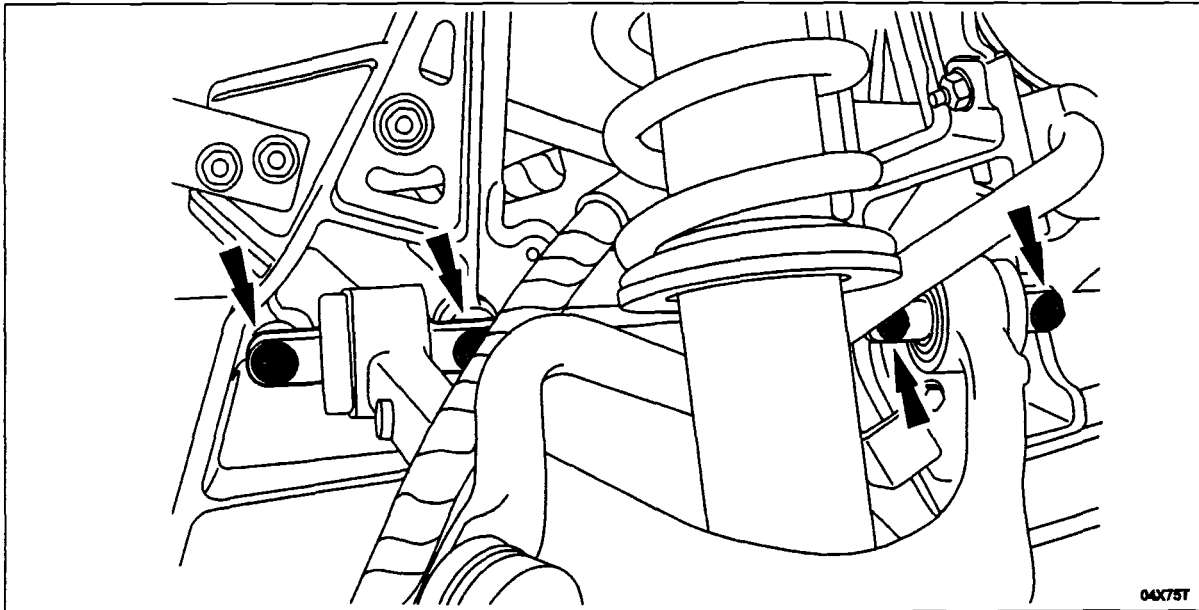

FIGURE 20

4. Recheck camber and re-adjust if necessary.
5. Recheck rear toe and re-adjust if necessary.

Adjust front toe as follows:

1. Center the steering wheel and hold in a straight forward position by attaching a rigid link from the steering wheel to the seat.
2. Remove the steering gear bellows clamp.
3. Hold the tie-rod end and loosen the nut.
4. NOTE: Do not allow the steering bellows to twist when the tie-rod is rotated.
Rotate the tie-rod as necessary.
5. Tighten the nut to 55 Nm (41 lb-ft), then apply a paint stripe to the nut and check the appropriate box on the Master Compliance Inspection Report.
6. Install the steering gear bellows clamp.
7. Recheck the toe setting and re-adjust if necessary.



Adjust front camber and caster as follows:

1. Loosen the lower control arm-to-frame bolts.
2. To adjust front camber, install the alignment shims between both bushings on the front lower control arm and the frame. Loosen bolts as necessary, but replace only one shim at a time. See Figure 21.

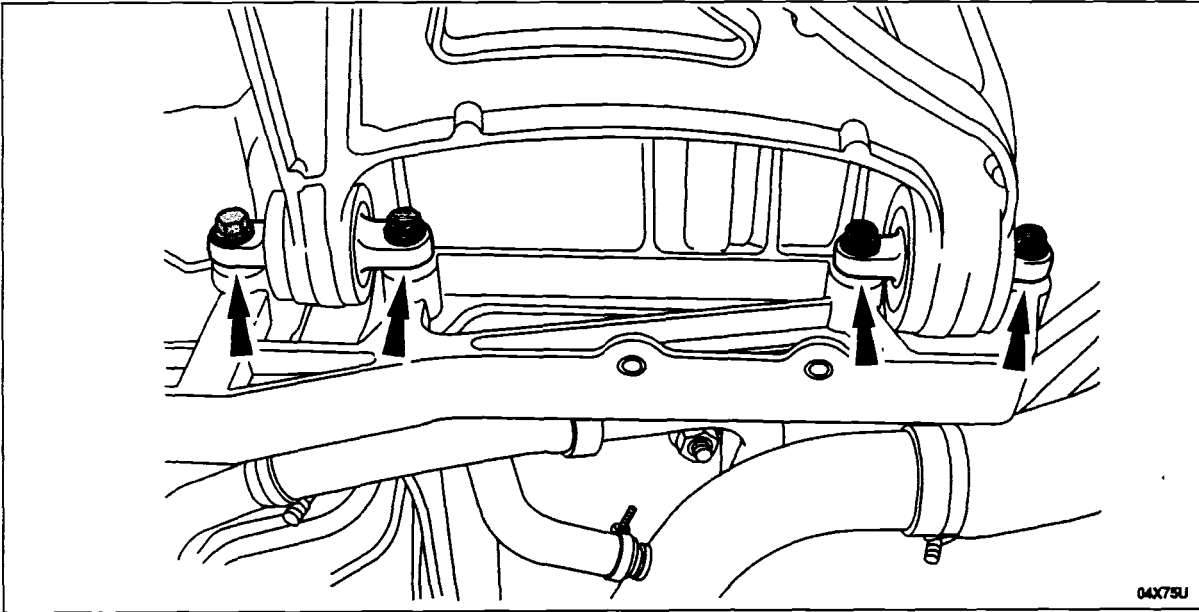

04X75U

FIGURE 21



3. **CAUTION:** When installing shims, be sure to place shims under both tabs of the bushing (at both bolts). Placing shims under only one tab of a bushing will not properly set the alignment.

To adjust front caster, install the alignment shims between the forward bushing on the front lower control arm and the frame. Loosen bolts as necessary, but replace only one shim at a time. See Figure 22.

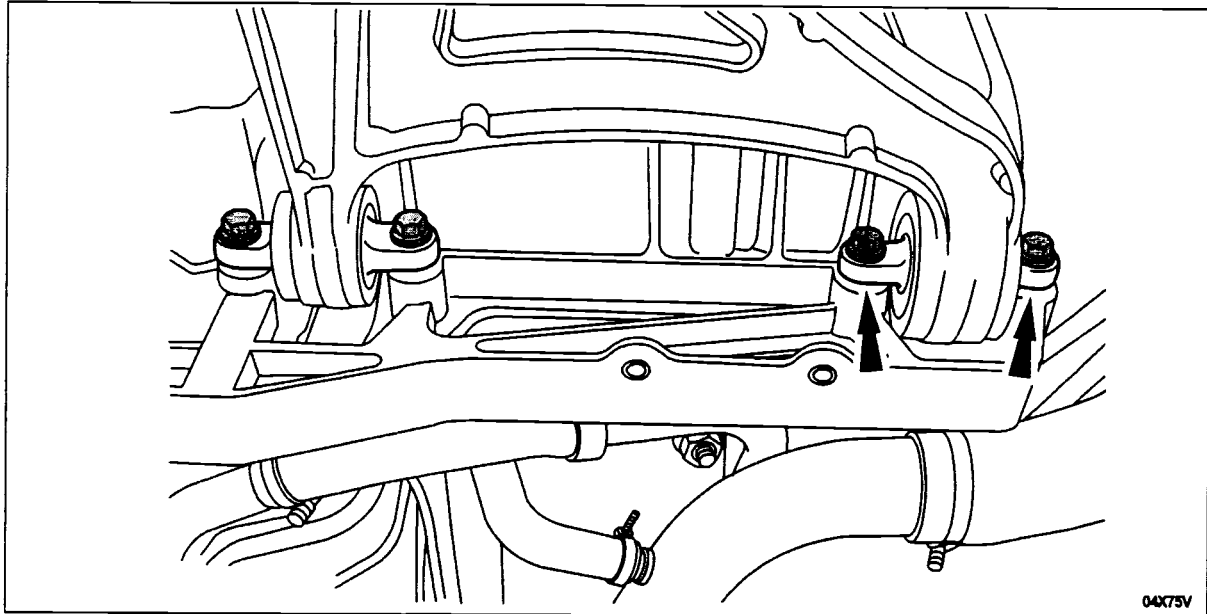

FIGURE 22

4. Tighten the bolts to 55 Nm (41 lb-ft), then apply a paint stripe to the bolts and check the appropriate box on the Master Compliance Inspection Report.
5. Recheck camber and caster and adjust if necessary.
6. Recheck front toe and re-adjust if necessary.

FINAL VEHICLE INSPECTION AFTER ALIGNMENT

1. Verify all fasteners have a paint stripe indicating the technician re-tightened each one to the proper torque specification after adjusting the alignment angles. As each fastener is inspected, check it off on the Master Compliance Inspection Report.



MANDATORY COMPLIANCE INSPECTION REPORT
SIGNIFICANT ASSEMBLIES & TORQUE INFORMATION

VIN: _____ Date: _____

APPLICATION/ PART NUMBERS	TORQUE SPECIFICATION	CHECK-OFF WHEN TIGHTENED TO SPEC.	SIGNIFICANT ASSEMBLY INSTRUCTIONS	SIGN-OFF COMPLETED	
				TECH	INSP
LEFT HAND FRONT					
LOWER CONTROL ARM TO FRAME W710548S439(4) WASHER W710154S438(4) M10x65 HF BOLT 4G7V-3A182(4) ALIGNMENT SHIMS	55 Nm (41 lb-ft)	Front 1 _____ 2 _____ 3 _____ Rear 4 _____	ALIGNMENT SHIMS MUST BE RE-INSTALLED WITH ORIGINAL COLORS IN ORIGINAL POSITION.		
LOWER CONTROL ARM TO KNUCKLE W708503S441(1) M14 NUT & WASHER	150 Nm (111 lb-ft)	1 _____			
UPPER CONTROL ARM TO FRAME W710200S438(4) M8x70 HF BOLT W710547S439(4) WASHER	30 Nm (22 lb-ft)	Front 1 _____ 2 _____ 3 _____ Rear 4 _____			
UPPER CONTROL ARM TO KNUCKLE W520214S440(1) M12 NUT	90 Nm (66 lb-ft)	1 _____	MUST BE SURE TO INSTALL PIA CONE WASHER @ TOP OF KNUCKLE.		
STABILIZER BAR LINK TO KNUCKLE W520213S427(1) NUT	55 Nm (41 lb-ft)	1 _____			
SHOCK ASSY TO LCA AND FRAME W500769S301(1) M14 X 95 BOLT W710155S438(2) M12 X 70 BOLT W710549S439(2) WASHER	SHOCK TO LCA 175.0 (129 lb-ft) SHOCK TO FRAME 103.0 (76 lb-ft)	To LCA _____ To Frame _____ To Frame _____			
BRAKE DISC TO HUB W505742S301(3) M8 X 20 BOLT	27.5 Nm (20 lb-ft)	1 _____ 2 _____ 3 _____			
CALIPER TO KNUCKLE 4G7V2C564BB (2) BOLT	100 Nm (74 lb-ft)	1 _____ 2 _____			
WHEEL TO HUB 4R33-1012-AA(5) NUT, OR 391455S100(5) NUT	133 Nm (98 lb-ft)	1 _____ 2 _____ 3 _____ 4 _____ 5 _____			



MANDATORY COMPLIANCE INSPECTION REPORT
SIGNIFICANT ASSEMBLIES & TORQUE INFORMATION

VIN: _____ Date: _____

APPLICATION/ PART NUMBERS	TORQUE SPECIFICATION	CHECK-OFF WHEN TIGHTENED TO SPEC.	SIGNIFICANT ASSEMBLY INSTRUCTIONS	SIGN-OFF COMPLETED		
				TECH	INSP	
RIGHT HAND FRONT						
LOWER CONTROL ARM TO FRAME W710548 S439 (4) WASHER W710154 S438 (4) M10x65 HF BOLT 4G7V-3A182 (4) ALIGNMENT SHIMS	55 Nm (41 lb-ft)	Front 1 _____ 2 _____ 3 _____ Rear 4 _____	ALIGNMENT SHIMS MUST BE RE-INSTALLED WITH ORIGINAL COLORS IN ORIGINAL POSITIONS.			
LOWER CONTROL ARM TO KNUCKLE W708503 S441 (1) M14 NUT & WASHER	150 Nm (111 lb-ft)	1 _____				
UPPER CONTROL ARM TO FRAME W710200 S438 (4) M8x70 HF BOLT W710547 S439 (4) WASHER	30 Nm (22 lb-ft)	Front 1 _____ 2 _____ 3 _____ Rear 4 _____				
UPPER CONTROL ARM TO KNUCKLE W520214 S440 (1) M12 NUT	90 Nm (66 lb-ft)	1 _____		MUST BE SURE TO INSTALL PIA CONE WASHER @ TOP OF KNUCKLE.		
STABILIZER BAR LINK TO KNUCKLE W520213 S427 (1) NUT	55 Nm (41 lb-ft)	1 _____				
SHOCK ASY TO LCA AND FRAME W500769 S301 (1) M14 X 95 BOLT W710155 S438 (2) M12 X 70 BOLT W710549 S439 (2) WASHER	SHOCK TO LCA 175.0 (129 lb-ft) SHOCK TO FRAME 103.0 (76 lb-ft)	To LCA _____ To Frame _____ To Frame _____				
BRAKE DISC TO HUB W505742 S301 (3) M8 X 20 BOLT	27.5 Nm (20 lb-ft)	1 _____ 2 _____ 3 _____				
CALIPER TO KNUCKLE 4G7V2C564 BB (2) BOLT	100 Nm (74 lb-ft)	1 _____ 2 _____				
WHEEL TO HUB 4R33-1012-AA (5) NUT, OR 391455 S100 (5) NUT	133 Nm (98 lb-ft)	1 _____ 2 _____ 3 _____ 4 _____ 5 _____				

MANDATORY COMPLIANCE INSPECTION REPORT
SIGNIFICANT ASSEMBLIES & TORQUE INFORMATION

VIN: _____ Date: _____

APPLICATION/ PART NUMBERS	TORQUE SPECIFICATION	CHECK-OFF WHEN TIGHTENED TO SPEC.	SIGNIFICANT ASSEMBLY INSTRUCTIONS	SIGN-OFF COMPLETED	
				TECH	INSP
RIGHT HAND REAR					
UPPER CONTROL ARM TO KNUCKLE W520214S440(1)M12NUT	90 Nm (66 lb-ft)	1 _____	MUST BE SURE TO INSTALL PIA CONE WASHER @ TOP OF KNUCKLE.		
LOWER CONTROL ARM TO FRAME W710548S439(4)WASHER W710154S438(4)M10x65HF BOLT	55 Nm (41 lb-ft)	Front 1 _____ 2 _____ 3 _____ Rear 4 _____			
UPPER CONTROL ARM TO FRAME W710200S438(4)M8x70HF BOLT W710547S439(4)WASHER 4G7V-5A802(4)ALIGNMENT SHIMS	30 Nm (22 lb-ft)	Front 1 _____ 2 _____ 3 _____ Rear 4 _____	ALIGNMENT SHIMS MUST BE RE-INSTALLED WITH ORIGINAL COLORS IN ORIGINAL POSITIONS.		
LOWER CONTROL ARM TO KNUCKLE W705516S426(1)M14 BOLT W705518S427(1)M14NUT	150 Nm (111 lb-ft)	1 _____			
TOE LINK TO KNUCKLE W702042S309(1)M10x110HF BOLT 4G7V3A182BB(2)BUMP STEER SHIM W520213S440(1)NUT	55 Nm (41 lb-ft)	1 _____	ALIGNMENT SHIMS MUST BE RE-INSTALLED WITH ORIGINAL COLORS IN ORIGINAL POSITIONS.		
STABILIZER BAR TO LINK W520213S427(1)NUT	55 Nm (41 lb-ft)	1 _____			
SHOCK ASSY TO KNUCKLE AND FRAME W500572S426(1)M14 X 110 BOLT W705518S427(1)NUT W710155S438(2)M12 X 70 BOLT W710549S439(2)WASHER	SHOCK TO KNUCKLE 175.0 (129 lb-ft) SHOCK TO FRAME 103.0 (76 lb-ft)	To Knuckle _____ To Frame _____ To Frame _____			
PARKING BRAKE CALIPER TO KNUCKLE 2W932C564 CB (2) BOLT	74 Nm (52 lb-ft)	1 _____ 2 _____			
CALIPER TO KNUCKLE 4G7V2C564 BB (2) BOLT	100 Nm (74 lb-ft)	1 _____ 2 _____			
WHEEL TO HUB 4R33-1012-AA(5)NUT, OR 391455S100(5)NUT	133 Nm (98 lb-ft)	1 _____ 2 _____ 3 _____ 4 _____ 5 _____			
HUB NUT N808405S100(1)M24 NUT	350 Nm (258 lb-ft)	1 _____			



MANDATORY COMPLIANCE INSPECTION REPORT
SIGNIFICANT ASSEMBLIES & TORQUE INFORMATION

VIN: _____ Date: _____

APPLICATION/ PART NUMBERS	TORQUE SPECIFICATION	CHECK-OFF WHEN TIGHTENED TO SPEC.	SIGNIFICANT ASSEMBLY INSTRUCTIONS	SIGN-OFF COMPLETED	
				TECH	INSP
LEFT HAND REAR					
UPPER CONTROL ARM TO KNUCKLE W520214S440(1)M12NUT	90 Nm (66 lb-ft)	1 _____	MUST BE SURE TO INSTALL PIA CONE WASHER @ TOP OF KNUCKLE.		
LOWER CONTROL ARM TO FRAME W710548S439(4)WASHER W710154S438(4)M10x65HF BOLT	55 Nm (41 lb-ft)	Front 1 _____ 2 _____ 3 _____ Rear 4 _____			
UPPER CONTROL ARM TO FRAME W710200S438(4)M8x70HF BOLT W710547S439(4)WASHER 4G7V-5A802(4)ALIGNMENT SHIMS	30 Nm (22 lb-ft)	Front 1 _____ 2 _____ 3 _____ Rear 4 _____	ALIGNMENT SHIMS MUST BE RE-INSTALLED WITH ORIGINAL COLORS IN ORIGINAL POSITIONS.		
LOWER CONTROL ARM TO KNUCKLE W705516S426(1)M14 BOLT W705518S427(1)M14NUT	150 Nm (111 lb-ft)	1 _____			
TOE LINK TO KNUCKLE W702042S309(1)M10x110HF BOLT 4G7V3A182BB(2)BUMP STEER SHIM W520213S440(1)NUT	55 Nm (41 lb-ft)	1 _____	ALIGNMENT SHIMS MUST BE RE-INSTALLED WITH ORIGINAL COLORS IN ORIGINAL POSITIONS.		
STABILIZER BAR TO LINK W520213S427(1)NUT	55 Nm (41 lb-ft)	1 _____			
SHOCK ASSY TO KNUCKLE AND FRAME W500572S426(1)M14X110 BOLT W705518S427(1)NUT W710155S438(2)M12X70 BOLT W710549S439(2)WASHER	SHOCK TO KNUCKLE 175.0 (129 lb-ft) SHOCK TO FRAME 103.0 (76 lb-ft)	To Knuckle _____ To Frame _____ To Frame _____			
PARKING BRAKE CALIPER TO KNUCKLE 2W932C564CB(2) BOLT	74 Nm (52 lb-ft)	1 _____ 2 _____			
CALIPER TO KNUCKLE 4G7V2C564BB(2) BOLT	100 Nm (74 lb-ft)	1 _____ 2 _____			
WHEEL TO HUB 4R33-1012-AA(5)NUT, OR 391455S100(5)NUT	133 Nm (98 lb-ft)	1 _____ 2 _____ 3 _____ 4 _____ 5 _____			
HUB NUT N808405S100(1)M24NUT	350 Nm (258 lb-ft)	1 _____			



MANDATORY COMPLIANCE INSPECTION REPORT
SIGNIFICANT ASSEMBLIES & TORQUE INFORMATION

VIN: _____ Date: _____

APPLICATION/ PART NUMBERS	TORQUE SPECIFICATION	CHECK-OFF WHEN TIGHTENED TO SPEC.	SIGNIFICANT ASSEMBLY INSTRUCTIONS	SIGN-OFF COMPLETED	
				TECH	INSP
ALIGNMENT					
RHTOELINKJAMNUT (IFADJUSTEDAFTERALIGNMENT)	55 Nm (41 lb-ft)	1 _____			
LHTOELINKJAMNUT (IFADJUSTEDAFTERALIGNMENT)	55 Nm (41 lb-ft)	1 _____			
RHREARUPPERCONTROLARM TOFRAME (IFADJUSTEDAFTERALIGNMENT)	30 Nm (22 lb-ft)	Front 1 _____ 2 _____ 3 _____ Rear 4 _____			
LHREARUPPERCONTROLARM TOFRAME (IFADJUSTEDAFTERALIGNMENT)	30 Nm (22 lb-ft)	Front 1 _____ 2 _____ 3 _____ Rear 4 _____			
RHTIERODJAMNUT (IFADJUSTEDAFTERALIGNMENT)	55 Nm (41 lb-ft)	1 _____			
LHTIERODJAMNUT (IFADJUSTEDAFTERALIGNMENT)	55 Nm (41 lb-ft)	1 _____			
LOWERCONTROLARMTOFRAME (IFADJUSTEDAFTERALIGNMENT)	55 Nm (41 lb-ft)	Front 1 _____ 2 _____ 3 _____ Rear 4 _____			
LOWERCONTROLARMTOFRAME (IFADJUSTEDAFTERALIGNMENT)	55 Nm (41 lb-ft)	Front 1 _____ 2 _____ 3 _____ Rear 4 _____			



DEMONSTRATION / DELIVERY HOLD: Safety Recall 04S26 – Supplement #1
Certain 2005 Ford GT Vehicles
Suspension Control Arm Replacement

Dealer Q & A

- Q. If an affected owner inquires about the timing of part availability and repair scheduling, what should we tell them?**
- A. Dealers or vehicle owners may contact the Ford SVT Information Center (1-800-367-3788) for parts status and repair scheduling updates. We anticipate that repairs will be completed on the majority of customer owned vehicles by mid-March.
- Q. How are appointments being made, and how will the arrival of the vehicle and the parts at my dealership be coordinated?**
- A. Ford SVT will contact the customer and will coordinate with the customer and their dealer to schedule a service appointment that is convenient for both. These appointments will be scheduled at least three days in advance of the actual repair date. Ford will then submit an order for the control arm parts kit to be shipped directly to the servicing dealer in advance of the scheduled repair date. The parts kit will be identified by DOR/COR #50343, and will be marked with the VIN of the vehicle for which the parts were ordered.
- Q. When will I receive parts to service my unsold vehicles?**
- A. As soon as sufficient service parts are available. Servicing customer's vehicles is our first priority and we anticipate having an adequate supply of parts to service all customer owned vehicles by the end of February 2005. At that time, we will begin to automatically ship parts to dealers to service their in-stock vehicles. These in-stock vehicle orders will be prioritized based upon vehicle build date, with parts for the earliest build vehicles being shipped first.
- Q. Am I authorized to perform TSB related repairs?**
- A. Yes. In an effort to maintain high levels of owner satisfaction with the Ford GT, dealers are authorized to perform the inspections, and if necessary, complete the TSBs listed in this bulletin, **but only after having received authorization from the vehicle owner.** When Ford SVT calls vehicle owners to schedule their service appointments, owners will be advised that their dealer will be performing additional performance related vehicle inspections, and that repairs resulting from these inspections will only be performed with the vehicle owner's permission. TSB related repairs must be submitted on a regular warranty claim, and must not be claimed against any recall program.



Frank M. Ligon
Ford Motor Company
P. O. Box 1904
Dearborn, Michigan 48121

January 2005

Safety Recall 04S26

Mr. John Sample
123 Main Street
Anywhere, USA 12345

Your Vehicle Identification Number: 12345678901234567

This notice is sent to you in accordance with the requirements of the National Traffic and Motor Vehicle Safety Act.

Ford Motor Company has decided that a defect which relates to motor vehicle safety exists in certain 2005 Ford GT vehicles.

We apologize for this situation and want to assure you that, with your assistance, we will correct this condition. Our commitment, together with Ford dealers, is to provide you with the highest level of service and support.

- | | |
|-------------------------------------------|---------------------------------------------------------------------------------------------------------------------------------------------------------------------------------------------------------------------------------------------------------------------------------|
| What is the issue? | Ford has identified a quality issue with the suspension control arms on the affected vehicles which may result in a control arm fracture. In the event of a control arm fracture, vehicle handling may be diminished and a crash potentially could occur without prior warning. |
| What will Ford and your dealer do? | Ford Motor Company and your dealer will replace the suspension control arms on your vehicle free of charge (parts and labor). |
| How long will it take? | Once parts are available, the time needed for this repair is two to three days. |

What are we asking you to do?

Your vehicle should not be driven until this recall service has been performed.

The Ford Special Vehicle Team (SVT) has been contacting owners of affected vehicles via phone. If you have not already been contacted, please call the Ford SVT Information Center at 1-800-367-3788 without delay.

Once parts become available, Ford SVT will coordinate making a service appointment for your vehicle with the dealer of your choice. In addition, Ford SVT will arrange for your vehicle to be transported in an enclosed carrier to have the service performed. Estimated timing for part availability is in February 2005.

Please note: Federal law requires that any vehicle lessor receiving this recall notice must forward a copy of this notice to the lessee within ten days.

Do you need a rental vehicle?

Your dealer is authorized to provide you with a luxury rental vehicle at no charge (except for fuel and insurance) until your vehicle has been repaired.

Have you changed your address or sold the vehicle?

If you have, please notify the Ford SVT Information Center at 1-800-367-3788 so that we can update our records.

Can we assist you further?

If you have difficulty getting your vehicle repaired promptly and without charge, please contact the Ford SVT Information Center at 1-800-367-3788.

If you are still having difficulty getting your vehicle repaired in a reasonable time or without charge, you may write the Administrator, National Highway Traffic Safety Administration, 400 Seventh Street S. W., Washington, D. C. 20590 or call the toll free Auto Safety Hotline at 1-888-327-4236 or 1-800-424-9393.

Thank you for your attention to this important matter.

Sincerely,



Frank M. Ligon
Director
Service Engineering Operations