

Volkswagen of America, Inc.

RECEIVED
APR 12 2005



2005 APR 12 A 10:35

DEFLECTOR INVESTIGATION

Product Compliance
3800 Hamlin Road
Auburn Hills, MI 48326
Tel. (248) 340-5000

April 11, 2005

Ms. Patricia Wallace
Recall Analyst for Safety Assurance
National Highway Traffic Safety Administration
NSA-11
U.S. Department of Transportation
400 Seventh Street, S.W.
Washington, DC 20590

**Subject: Recall Campaign UY (04V-592)
2004-2005 Model Year Volkswagen Touareg Vehicles
Inspect Rear Outboard Seat Belts and, if Necessary, Install Belt Shortening Clips**

Dear Ms. Wallace:

Pursuant to the requirements set forth in Part 573.5 of Title 49 of the Code of Federal Regulations, we are submitting three (3) copies of the following communications:

- Dealer Notification
- Customer Notification
- Work Procedure
- Accounting Procedure

Sincerely,

A handwritten signature in cursive script that reads 'Maria Cotter'.

Maria Cotter
Product Compliance

Enclosures

Volkswagen of America, Inc.



3800 Hamlin Road
Auburn Hills, MI 48326

April 2005

**Subject: REVISION to Compliance Recall UY
2004-2005 Model Year Volkswagen Touareg Vehicles
Inspect Rear Outboard Seat Belts and, if Necessary, Install Belt Shortening Clips**

Dear Volkswagen Dealer Principal and Service Manager:

This letter is to inform you that the UY Compliance Recall circular has been revised. Please discard any previous copies of the circular that you may have and refer to the **REVISED UY** circular that will be posted on VESIS and on the VW Hub shortly.

IMPORTANT!

All claims for repairs performed under the previous version of the UY circular must be entered on or before April 24, 2005. Failure to do so may result in non-payment of your claim.

The UY compliance recall involves some 2004-2005 model year Volkswagen Touareg vehicles. Volkswagen has determined that a non-compliance with Federal Motor Vehicle Safety Standard No. 208 exists in some 2004 and early 2005 model year Touareg vehicles. The affected rear outboard seat belts may not properly secure a limited number of child restraints when using the Automatic Locking Retractor (ALR) mode of the seat belt.

Federal law prohibits any person from knowingly selling, or offering for sale, any motor vehicle that does not comply with applicable motor vehicle safety standards prescribed under Chapter 301 ("Motor Vehicle Safety") of Title 49, United States Code. It is therefore imperative that any vehicle in your inventory that is affected by this recall is corrected prior to delivery for sale or lease.

Touareg vehicles produced either after September 20, 2004 (starting after VIN WVGMM77L35D030830) or with a seat belt date code as described in the UY Compliance Recall circular are not affected and can be sold without delay.

The rear outboard seat belts on affected vehicles **MUST BE INSPECTED** and, **IF NECESSARY**, have seat belt clips installed. Please note that, even if only one rear outboard seat belt meets the criteria for clip installation, clips must be installed on both rear outboard seat belts.

We are working diligently to obtain additional stock of clips; however stock will be limited in the beginning.

Please refer to the **REVISED Compliance Recall Circular UY** posted on web VESIS and on the VW HUB for additional information, and please be sure to share this information with all personnel with campaign-related responsibilities.

Thank you for your cooperation and assistance in this important matter.

Sincerely,

A handwritten signature in cursive script, appearing to read 'Maria Cotter'.

Maria Cotter, Product Compliance

Important! Please Provide A Copy To All Personnel With Campaign-Related Responsibilities!
THIS REPLACES THE UY CIRCULAR DATED JANUARY 2005



Compliance Recall Circular

REVISED Code: UY

April 2005

**Subject: 2004-2005 Model Year Touareg Vehicles
Inspect Rear Outboard Seat Belts and, If Necessary,
Install Seat Belt Shortening Clip(s)**

This is to inform you of the initiation of a compliance recall involving some 2004-2005 model year Touareg vehicles.

Problem Description

Volkswagen has found that some 2004-2005 model year Touareg vehicles may not fully comply with a part of Federal Motor Vehicle Safety Standard (FMVSS) 208 regarding the use of the seat belt locking feature.

This locking feature is used when installing a child seat in the rear outboard seating positions. A small number of child seats cannot be installed as required by FMVSS 208 because they have a very short belt routing path.

This condition does not affect adult use of the seat belts, nor does it affect the center rear seat belt.

Remedial Action

Inspect both rear outboard seat belts and, if necessary, install seat belt shortening clips at the rear outboard seating positions.

Additionally, an owner's manual insert entitled "Child Restraint Installation in Your Vehicle" must be inserted in the owner's manual of each affected vehicle in the section before Booklet 2.1, "Safety First."

**Vehicle Identification
Number Range**

The vehicles affected by this action are within the following vehicle identification number range:

WVG__7L_4D000056 - WVG__7L_5D030829

Please note that the above VINs represent the lowest and highest serial numbers of affected vehicles. Use of the OTIS campaign inquiry system will allow you to determine whether or not a particular vehicle, within the above VIN range, requires the corrective work.

Note: It is recommended that a screen print of the OTIS View Campaign Inquiry screen be attached to the repair order. Volkswagen will not reimburse under this action any duplicate repair work or a repair outside the VIN range.

**Limitation of Sale or
Lease of Certain
Vehicles**

Federal law prohibits any person from knowingly selling, or offering for sale, any motor vehicle that does not comply with applicable motor vehicle safety standards prescribed under Chapter 301 ("Motor Vehicle Safety") of Title 49, United States Code. **It is therefore imperative that any vehicle in your inventory that is affected by this recall is corrected prior to delivery for sale or lease.**

Owner Notification Mailing

Volkswagen will notify all known owners of affected vehicles directly by first-class mail on or about April 11, 2005. Each notification letter will include an owner’s manual insert entitled “Child Restraint Installation in Your Vehicle”. They will be instructed to place the insert in their owner’s manual in the section before Booklet 2.1, “Safety First.” A sample copy of the owner notification letter is enclosed for your information.

Parts Information

You may receive an initial allocation of parts. During the campaign launch period, parts will be blocked and released by VIN through Special Services. Refer to the VWHub for campaign parts updates. After the launch period, the block may be lifted and then parts can be ordered through your facing parts depot. For your in-stock vehicles, you can order copies of the owner’s manual insert entitled “Child Restraint Installation in Your Vehicle” from Resolve Corporation by calling 800-544-8021.

Additional Campaigns

Some of the affected vehicles may be involved in an additional corrective action. Please check your OTIS View Campaign inquiry screen so that any additional required work can be done simultaneously.

Time Requirements/ Reimbursement

To ensure prompt and proper payment, be sure to enter, immediately upon completion of the repair work, the applicable reimbursement code listed below. Claims will only be paid for vehicles that show the **UY** code in the OTIS View Campaign inquiry screen on the day of repair. It is therefore recommended that a screen print of the OTIS View Campaign inquiry screen be attached to the repair order.

UY Data Entry Procedure

Repair Code <small>(Damage Code Field)</small>	Time Units	Work Scope
UY 11	10 T.U.	- Check both rear outboard seat belts; No further work required
UY 15	20 T.U.	- Inspect both rear outboard seat belts; Install clip on left & right rear outboard seat belts 2 7L0 857 837 Bracket with locking clamp

There is NO reimbursement for Vehicle Wash or Loaner Vehicle.

The system automatically enters labor and parts applicable to the above listed codes.

For vehicles that, according to your information, cannot be corrected or reached, and one of the codes below best describe the reason, please enter one of the applicable codes into the system:

- **UY 20 Customer Refused Repairs**
- **UY 30 Total Loss**
- **UY 40 Vehicle Stolen**
- **UY 50 Vehicle Exported**

Supplemental Reimbursement

If, in accordance with instructions by the Campaign Helpline, you are required to perform additional work to replace one or both rear outboard seat belts ONLY, please enter a separate claim using the claim type RC and damage code UYAB. The "Comments" section requires an explanation of the repair and the name of the Helpline person who authorized the repair, accompanied by the "Helpline Authorization Number."

DO NOT perform this additional work unless you have obtained an authorization number from the Campaign Helpline at (800) 741-2919. Failure to obtain an authorization number prior to performing the work will result in non-payment of your claim.

UYAB Additional Repair Claim Entry Information

To claim extra time and parts for replacement of one or both rear outboard seat belts us the following:

UYAB Data Entry Procedure

Repair Code (Damage Code Field)	Time Units	Work Scope
UY AB	160 T.U.	- Check both rear outboard seat belts; Replace one rear outboard seat belt
		1 7L0 857 805A *** Rear seat belt -Left
		<u>or</u> 1 7L0 857 806A *** Rear seat belt -Right
UY AB	220 T.U.	- Inspect both rear outboard seat belts. Replace left & right rear outboard seat belts
		1 7L0 857 805A *** Rear seat belt -Left
		1 7L0 857 806A *** Rear seat belt -Right

There is NO reimbursement for Vehicle Wash or Loaner Vehicle.

Campaign Verification

For verification, **always** check the OTIS View Campaign inquiry screen. The OTIS system is the **only** binding campaign inquiry and verification source; other sources **are not valid and may result in non-payment of a claim.**

Service Help

If you have a question regarding this or any other campaign, please call (800) 741-2919.

Dealer Personnel Information

Please inform and/or provide a copy of this communication to every person in your dealership who has campaign-related responsibilities, including parts and accounting personnel.

Thank you for your cooperation.

Sincerely,



Maria Cotter
Product Compliance

Volkswagen of America, Inc.



3800 Hamlin Road
Auburn Hills, MI 48326

April 2005

**Subject: Compliance Recall UY
2004-2005 Model Year Touareg Vehicles – CHILD SEAT INSTALLATION
Inspect Rear Outboard Seat Belts and, if Necessary, Install Seat Belt Shortening Clips**

Dear Volkswagen Owner:

This notice is sent to you in accordance with the requirements of the National Traffic and Motor Vehicle Safety Act.

Volkswagen has determined that some 2004 - 2005 model year Touareg vehicles fail to conform to the requirements of Federal Motor Vehicle Safety Standard (FMVSS) 208, "Occupant Crash Protection," regarding the use of the seat belt locking feature. This locking feature is used when installing a child seat in the rear outboard seating positions. Our records show that you are the owner of one of these vehicles.

What Is The Problem?

Certain child seats that have a very short belt routing path cannot be installed as required by FMVSS 208.

If you have a child seat that was built with the LATCH system, you can use the LATCH system in the vehicle to properly secure the child seat. Again, be sure to always follow the instructions that came with the child seat.

This condition does not affect adult use of any seat belt, nor does it affect child seat installation in the center rear seat location.

Except for the driver's position, all Touareg seat belts are equipped with retractors that convert from an emergency locking retractor (ELR) to an automatic locking retractor (ALR). This locking feature is used when installing a child seat. The belts convert to the ALR mode after the webbing has been pulled all the way out of the retractor. As the belt is then released into the retractor, the system remains in the ALR mode so that the belt can be tightened to secure a child restraint.

However, when installing a child restraint with a very short belt path in either of the rear outboard seating positions, the retractor may return to the ELR mode before all of the belt webbing has been fed back into the retractor. If this happens, a child restraint with a short belt path will not be properly secured as determined by the FMVSS requirement. Failure to properly restrain the child seat safely could result in injury to the child in a crash.

What Will Volkswagen Do?

In order to identify and correct this condition, we will inspect the rear outboard seat belts on your vehicle and, if necessary, install special clips.

Additionally, enclosed with this letter is an owner manual supplement entitled "Child Restraint Installation in Your Vehicle." Please read this insert carefully and file it in your owner's manual before booklet 2.1, "Safety First."

What We Would Like You To Do

If you do not have, or do not expect to have, a child seat installed in the rear outboard seating positions, please contact your authorized Volkswagen dealer and arrange for an appointment in May, 2005 so that this recall work can be performed on your vehicle at that time.

If you now have, or expect to have, a child seat installed in either of the two rear outboard seating positions, please contact your authorized Volkswagen dealer without delay to arrange for an appointment so that this recall work can be performed before installation of the child seat.

This service should take less than one half hour; however, your dealer may need additional time for the preparation of the repair as well as to accommodate the daily workshop schedule. This work will, of course, be free of charge.

About the Seat Belts in Your Vehicle

Since this noncompliance will affect only a small number of child restraints, we would like you to know that adults can use the rear seat belts normally.

Most child seats can be secured in your vehicle in accordance with FMVSS 208 requirements. This includes rear-facing infant seats, most forward-facing child seats, and booster seats. Only a few child seats will use so little seat belt length to cause the retractor to switch from ALR to ELR mode.

When using a child seat in your vehicle, be sure to always follow the instructions that came with the child seat, and be sure to always put the seat belt height adjuster in the top-most position. Since the center rear seat belt is not affected by this noncompliance, this seating position is an option for securing the small number of child seats that cannot be installed in the rear outboard positions as per FMVSS 208.

If you have a child seat that was built with the LATCH system, you can use the LATCH system in the vehicle to properly secure the child seat. Again, be sure to always follow the instructions that came with the child seat.

Lease Vehicles

If you are the lessor and registered owner of the vehicle identified in this action, the law requires you to forward this information immediately via first-class mail to the lessee within ten (10) days of receipt of this notification.

Have You Changed Your Address Or Sold The Vehicle?

If you have, please fill out the enclosed prepaid Owner Reply card and mail it to us so we can update our records.

Reimbursement of Expenses

If you have previously paid for replacement of the rear outboard seat belts because they would not secure a child restraint, the enclosed form explains how to request reimbursement. We would be pleased to review your reimbursement request.

Service Help from Us

If your authorized Volkswagen dealer fails or is unable to complete this work free of charge within a reasonable time, please call or write to:

Volkswagen of America, Inc.
Attn: Customer CARE Center – Hills East (UY)
3499 West Hamlin Road
Rochester Hills, MI 48309
1-800-893-5298

If you still cannot obtain satisfaction, you may file a complaint with: Administrator, National Highway Traffic Safety Administration, U.S. Department of Transportation, 400 Seventh Street, SW, Washington, DC 20590. Telephone: (888) 327-4236.

We regret any inconvenience this matter may cause. Thank you for driving a Volkswagen!

Sincerely,

Maria Cotter
Product Compliance

Parts:

<u>Quantity</u>	<u>Part Number and Date</u>	<u>Part Name</u>
2	7L0 857 837	Bracket with locking clamp (Set)

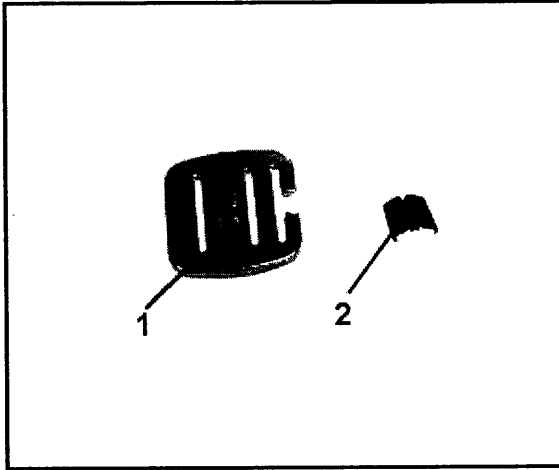

← 7L0 857 837 - Bracket -3- with locking clamp -2-

Work Sequence:

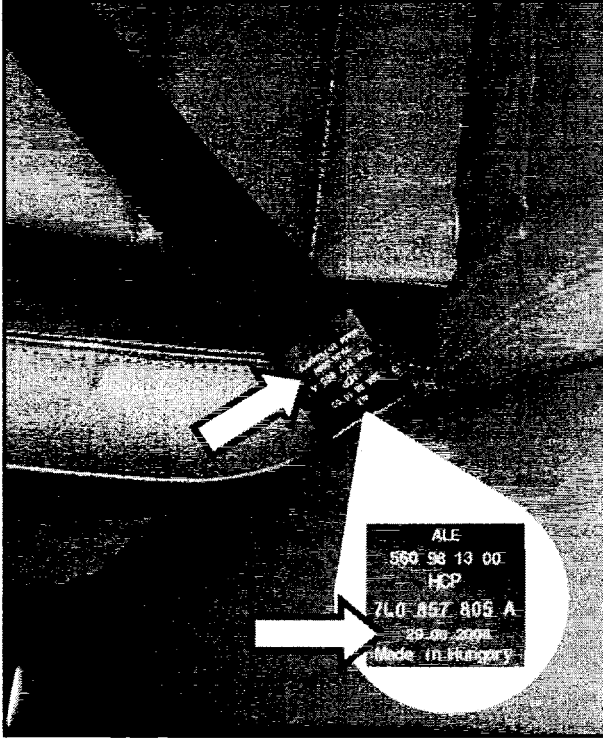

Section A – Check Rear Seat Belt Identification Label

- Open both rear doors
- ⇐ Illustration is showing left rear seat belt
- ⇐ Check the date -arrow- on the left and right outer rear seat belt labels;

Note: The date is shown in day, month year (dd.mm.yyyy) format

- If the date is 07.08.2004 (**7 August 2004**) or later on the left and right seat belt label, no further work is required
- If the date is earlier then 07.08.2004 on either seat belt for proceed to Section B

Section B – Install Bracket and Locking Clamp on Rear Seat Belts

Note: All illustrations in this section show the right side of vehicle

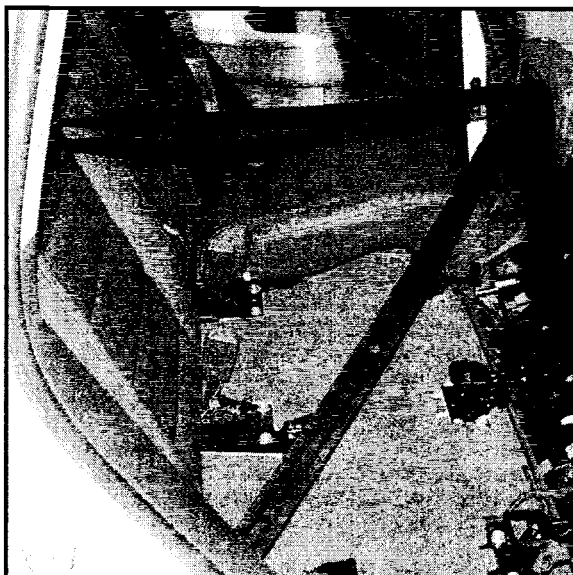

- ⇐ Tilt the rear seat bottom forward and pull the rear seat belt out approximately 90 to 100 cm (35 to 40 in.)

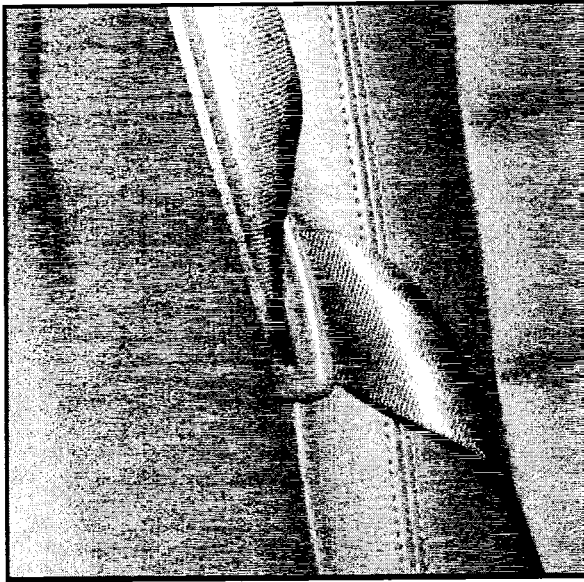

- ⇐ While holding the seat belt pulled out, slide the seat belt tongue along the belt and carefully wedge it between the rear seat back and the C pillar trim to prevent the seat belt from retracting

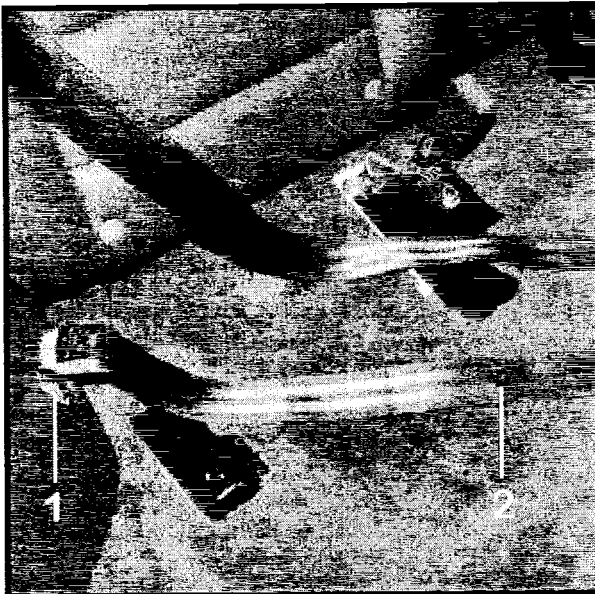

- ⇐ Lay the seat belt flat on the vehicle floor without twisting the belt
- ⇐ Locate the mid-point approximately halfway between the seat belt anchor point -1- and the latch stop button -2-

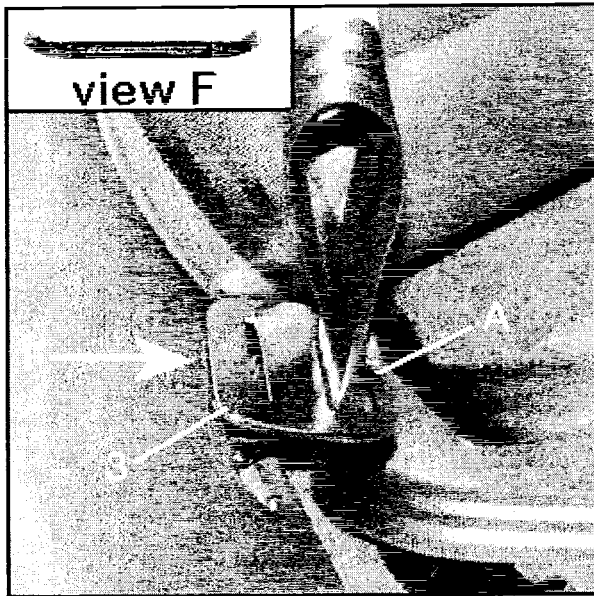

⇐ Hold bracket -3- (7L0 857 837) over the seat belt with the cut slot end -A- pointing toward the center of the vehicle and the angled sides facing upward -view F-

⇐ Insert the previously found mid-point of the seat belt into the middle slot of the bracket and pull the set belt through the slot until the latch stop button and seat belt anchor point contacts the bottom of the bracket

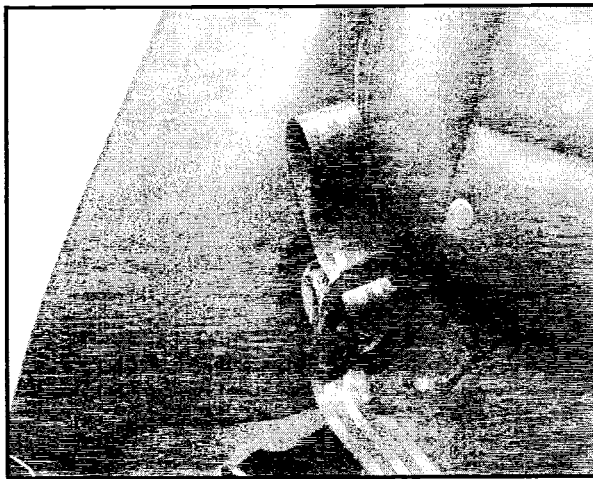

⇐ Fold mid-point of seat belt down and insert into outer slot of bracket

- Pull mid-point of seat belt completely through outer slot and remove any slack while making certain the bracket is still tight against the latch stop button and seat belt anchor point

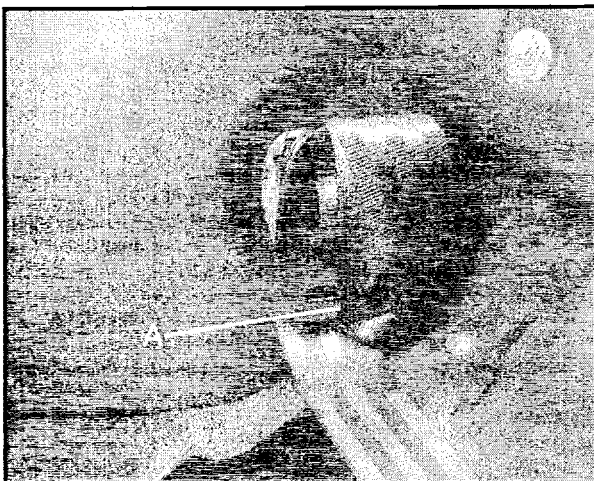

⇐ Fold the seat belt over the top of the bracket and insert seat belt through the cut -A- and into the slot then spread seat belt completely across the slot and over outer edge

- Make certain the seat belt is centered over the slot and outer edge

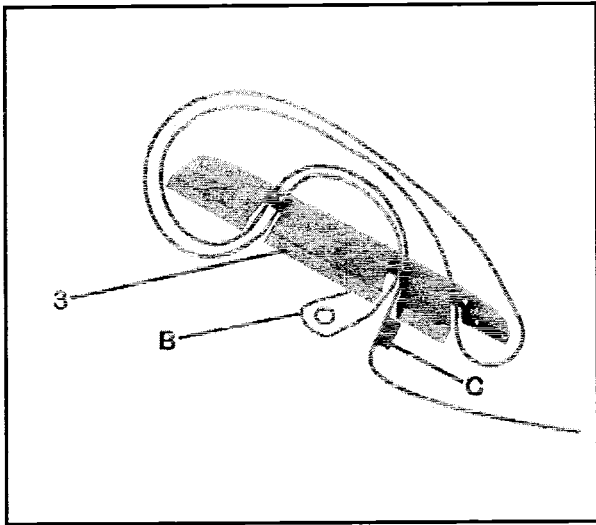

⇐ Reference illustration showing seat belt routing in bracket

- Bracket -3- is shown cut in half for illustrative purposes
- Seat Belt anchor point -B-
- Seat Belt latch stop button -C-

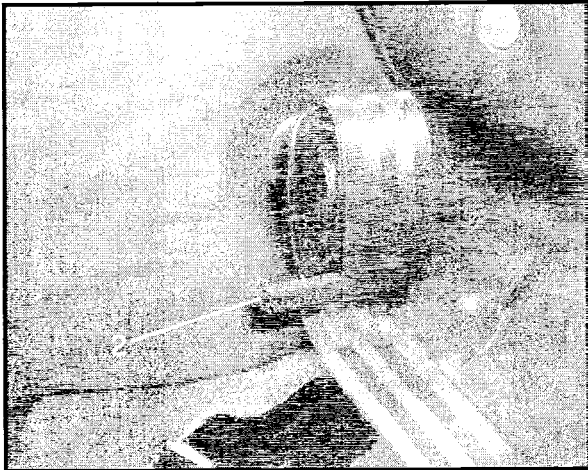

⇐ Slide the locking clamp -2- across the bracket between the seat belt and the cut slot end

- Squeeze the locking clamp together with your fingers until it locks together over the cut slot end



⇐ Hold the bracket in one hand pull the seat belt until the slack has been removed

- Remove seat belt tongue from area between seat back and C pillar trim

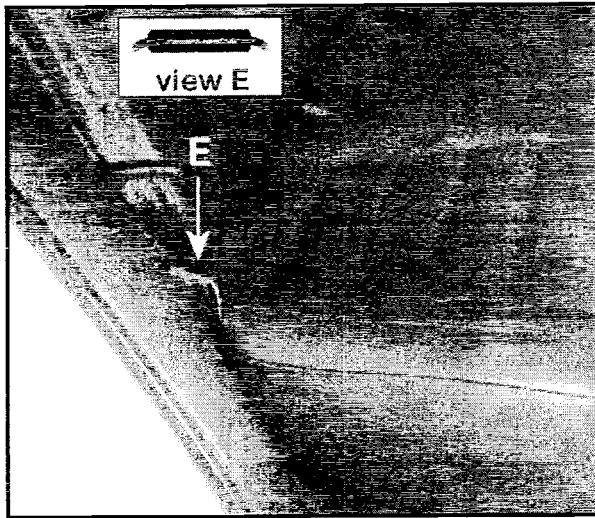

- Reposition rear seat bottom
- ⇐ The bracket should be located close to the seat belt anchor point with the latch stop button visible above it and the angled sides of the bracket are pointing outward -view E-
- Repeat procedure for opposite side seat belt
(EVEN IF ONLY ONE REAR OUTBOARD SEAT BELT MEETS THE CRITERIA FOR BRACKET INSTALLATION, BRACKETS MUST BE INSTALLED ON BOTH REAR OUTBOARD SEAT BELTS)

Additional Campaign Work Procedure

UYAB

DO NOT perform this additional work unless you have obtained an authorization number from the Campaign Helpline at (800) 741-2919. Failure to obtain an authorization number prior to performing the work will result in non-payment of your claim.

Parts:

Quantity	Part Number and date	Part Name
1	7L0 857 805 A *** dated 07.08.2004 or later	Rear Seat Belt Left
1	7L0 857 806 A *** dated 07.08.2004 or later	Rear Seat Belt Right
	Shop Supplies	Loctite® threadlocker blue 242

(*** Color code per ETKA)

Special Tools:

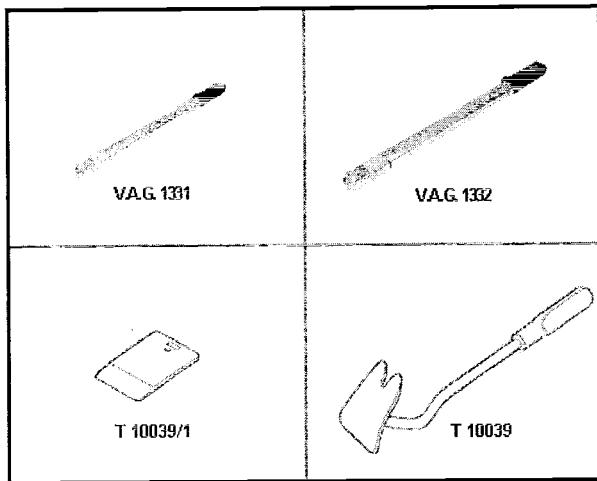

⇐ Torque wrench V.A.G. 1331 or equivalent

⇐ Torque wrench V.A.G. 1332 or equivalent

⇐ Wedge T 10039/1 or equivalent

⇐ Wedge T 10039 or equivalent

Work Sequence:

**Section A – Check Rear Seat Belt
identification label**

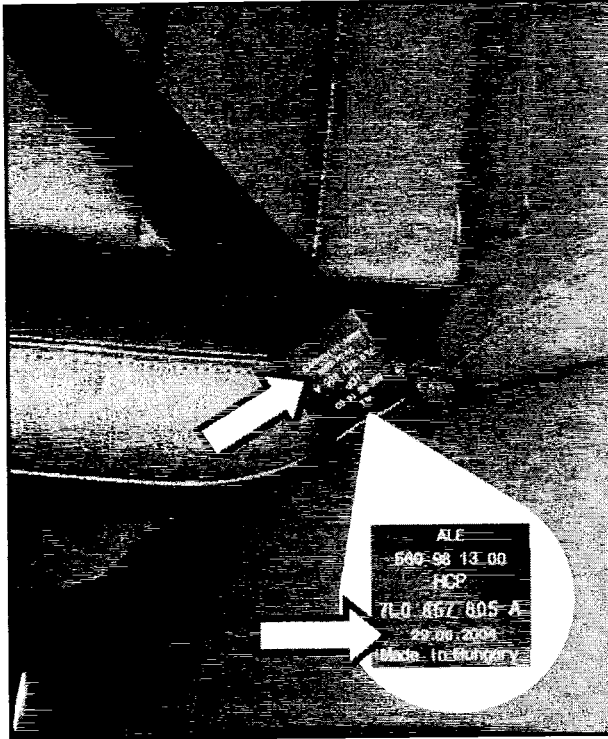

- Open both rear doors
- ⇐ Illustration is showing left rear seat belt
- ⇐ Check the date -arrow- on the left and right outer rear seat belt labels;

Note: The date is shown in day, month year (dd.mm.yyyy) format

- If the date is 07.08.2004 (7 August 2004) or later, no further work is required
- If the date is earlier then 07.08.2004, the seat belt needs to be changed, proceed to Section B

Section B – Rear Seat belt removal



WARNING

Observe safety precautions for belt tensioners

- Disconnect batteries



WARNING

Prior to handling or servicing batteries, read, understand and observe the Warning and Safety measures for lead-acid batteries

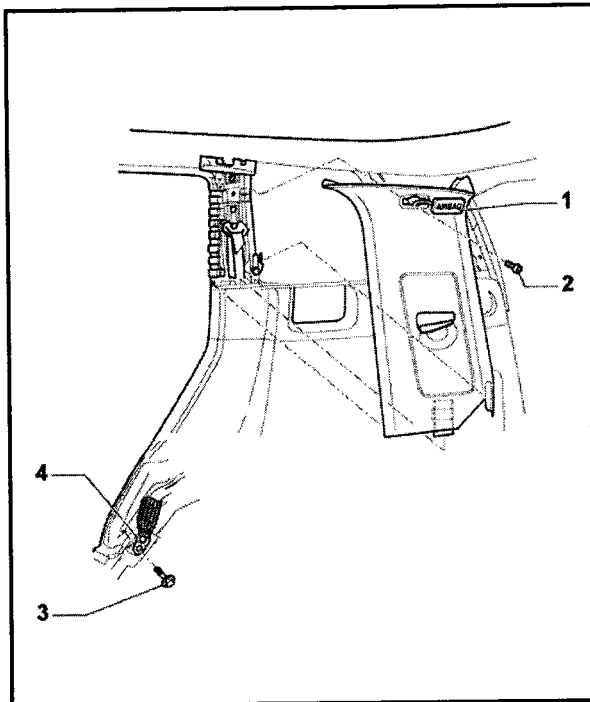

⇐ Remove air bag emblem -1- and remove screw -2-

⇐ Fold seat cushion forward and remove bolt -3-

⇐ Remove belt anchor -4- from body

- Pull C-pillar trim out of mountings in body and door seal molding
- Remove trim and pull seat belt through opening

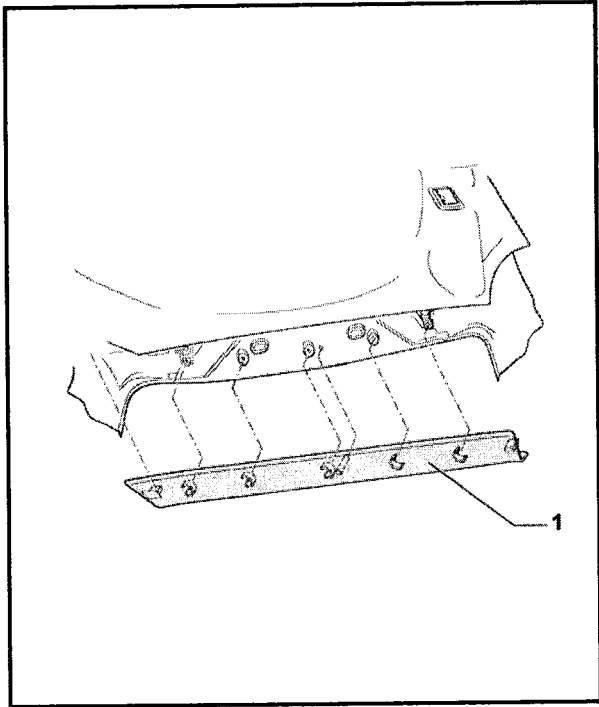

- Open tailgate
- ⇐ Pull roof end strip -1- downward out of mounting in roof

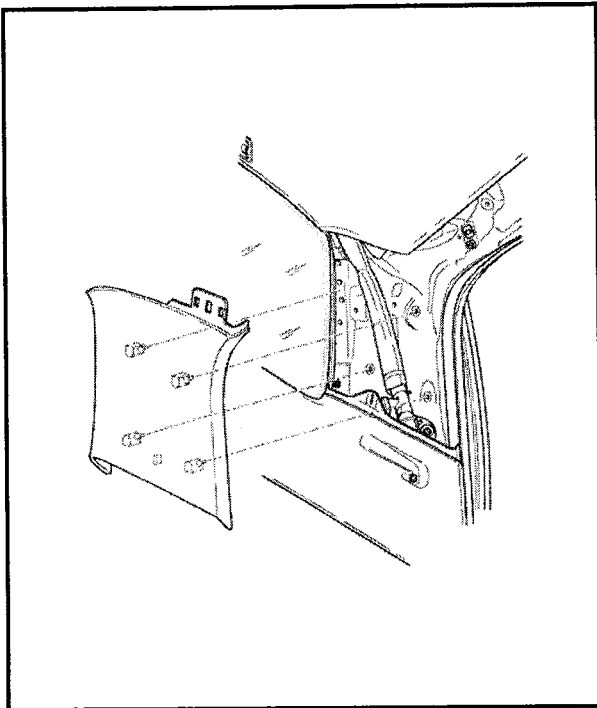

- ⇐ Pull D-pillar trim out of mountings in body and door seal molding

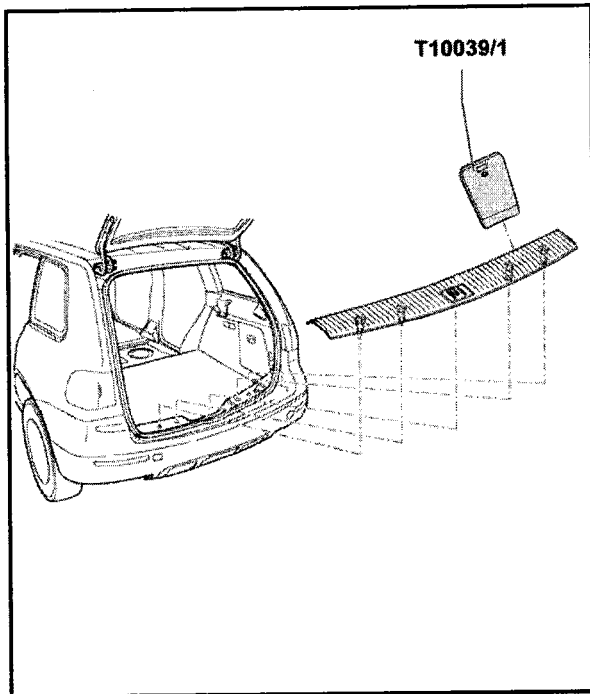

- ⇐ Open spare wheel cover
- ⇐ Using wedge T10039/1, pry lock carrier upward out of mountings

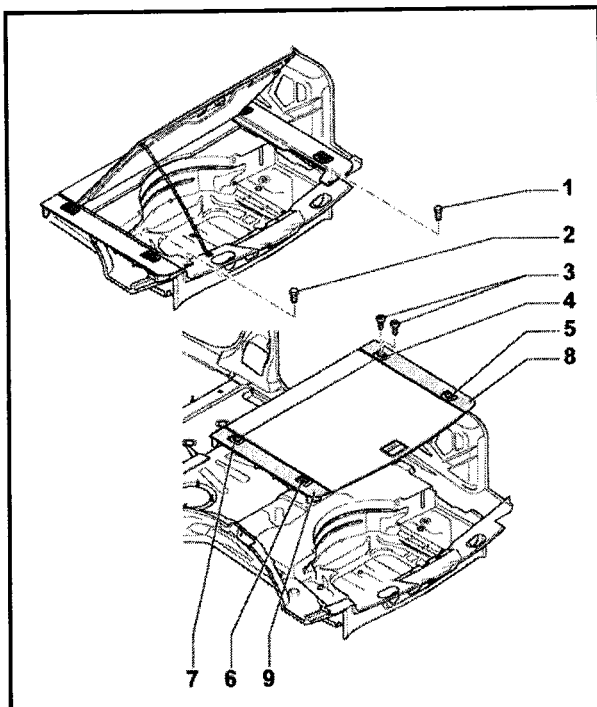

- ⇐ Remove bolts -1- and -2-
- Close spare wheel cover
- ⇐ Remove 2 bolts -3- and remove securing eye -4-
- ⇐ Remove securing eyes -5-, -6- and -7-
- ⇐ Remove spare wheel cover, right cover support -8- and left cover support -9- from the vehicle

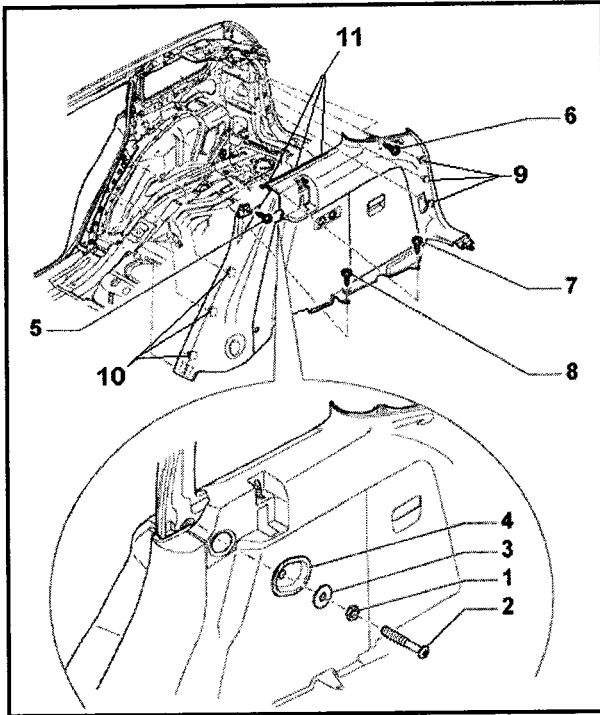

- ⇐ Loosen lock nut -1- and remove locking pin -2-
- ⇐ Remove washer -3- and trim -4-
- ⇐ Remove bolts -5-, -6-, -7- and -8-
- ⇐ Use wedge T 10039 and pull out trim panel retaining clips -9- and -10- out of holes in body
- ⇐ Carefully lift trim panel at rear and pull off of retaining clips -11-

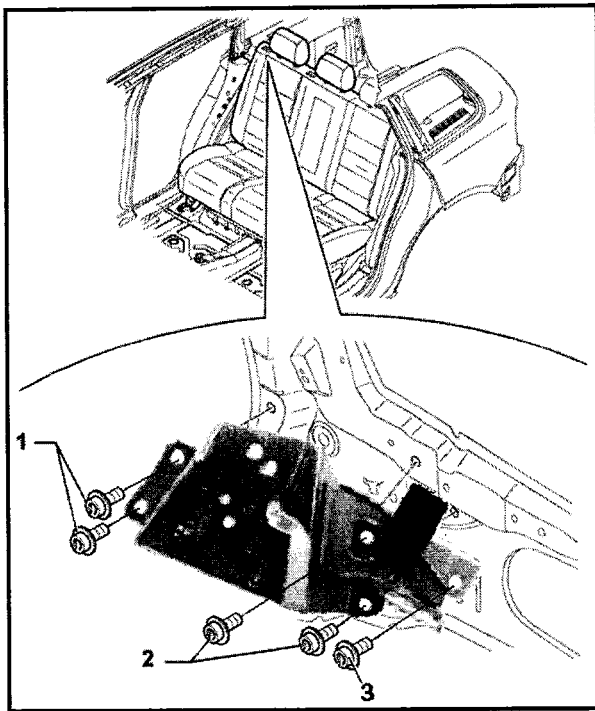

- ⇐ Remove Torx bolts -1-
- ⇐ Remove Torx bolts -2-
- ⇐ Remove hexagon bolt -3- and back rest mounting bracket

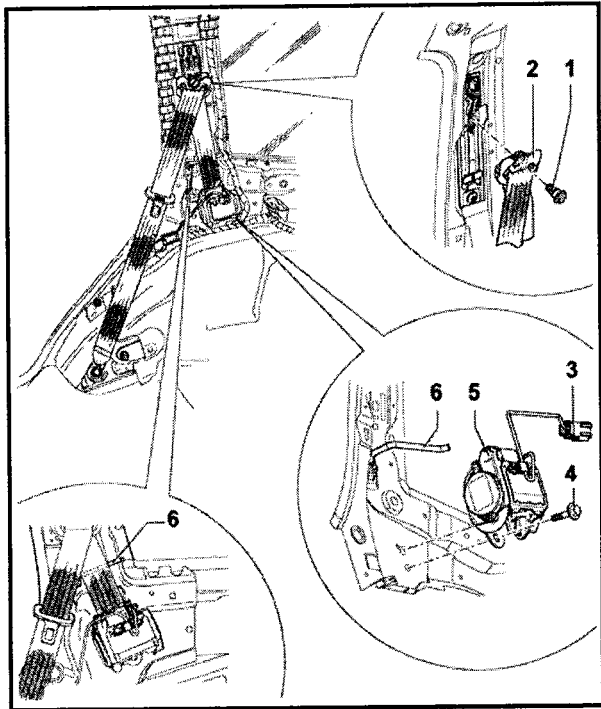

- ⇐ Remove bolt -1- and pull belt relay -2- off belt height adjuster



WARNING

Electrostatic discharges can result in an inadvertent deployment of Airbag. Therefore, mechanic/technician must electrostatically discharge him/herself, before separating ignition and Ground (GND) wire. This is done e.g. by briefly touching body or door striker or pin.

- ⇐ Disconnect connector -3-
- ⇐ Remove bolt -4- and remove inertia reel -5- from body

Section C - Seat Belt Installation

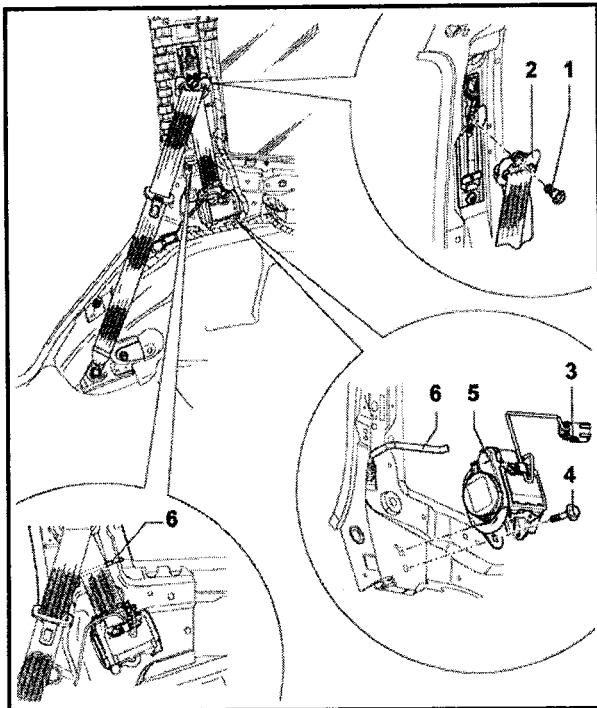

- ⇐ Install new seat belt (7L0 857 805A/806A dated 07.08.2004 (**7 August 2004**) or later) and using the V.A.G 1332 torque wrench, tighten bolt -4- to 50 Nm (37 ft. lbs.)

- ⇐ Reconnect connector -3-



WARNING

Electrostatic discharges can result in an inadvertent deployment of Airbag. Therefore, mechanic/technician must electrostatically discharge him/herself, before separating ignition and Ground (GND) wire. This is done e.g. by briefly touching body or door striker or pin.

- ⇐ Secure belt relay -2- to belt height adjuster and tighten bolt -1- to 50 Nm (37 ft. lbs.)

Note: When installing, ensure that the belt webbing runs over belt guide -6-

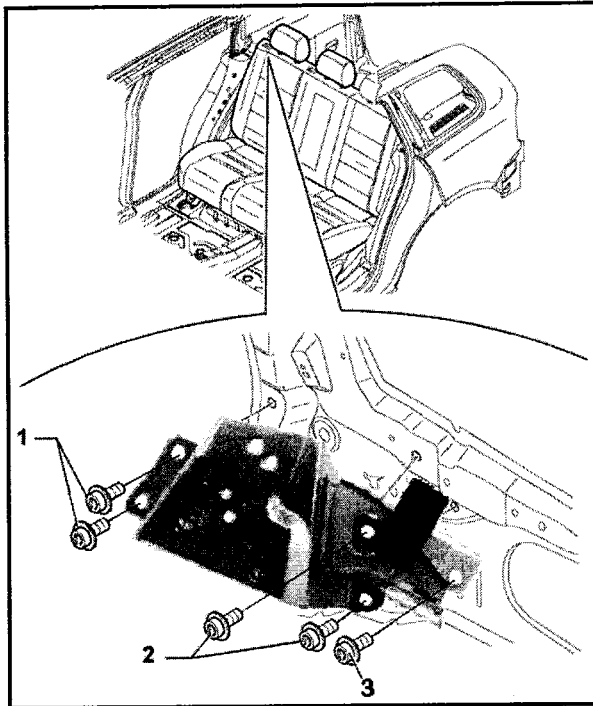

- Using a wire brush, clean the threads on bolts -1-, -2- and -3-
- Apply Loctite® threadlocker blue 242 to threads on bolts -1-, -2- and -3-
- ⇐ Reinstall backrest mounting bracket, secure with Torx bolts -1- and -2- and tighten to 20 Nm (15ft. lbs.)
- ⇐ Reinstall hex bolt -3- and tighten to 20 Nm (15ft. lbs.)

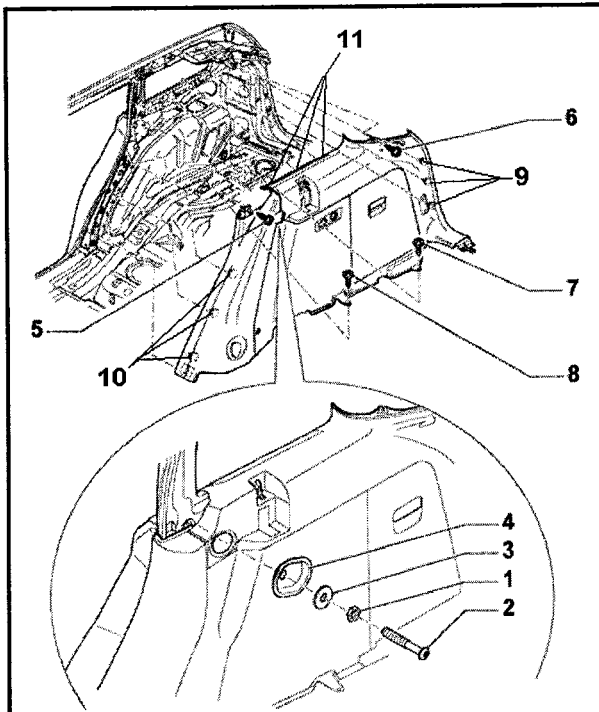

- ⇐ Reinstall side trim onto clips -11-
- ⇐ Attach side trim to body with clips -10- and -9-
- ⇐ Secure trim with bolts -5-, -6-, -7- and -8-
- ⇐ Reinstall trim -4- and washer -3-
- ⇐ Reinstall locking pin -2- and tighten lock nut -1-

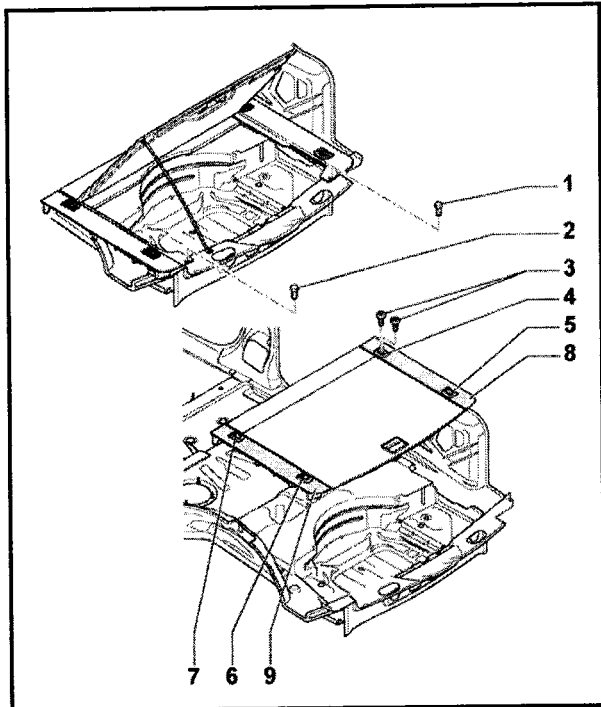

⇐ Reinstall right cover support -8- and left cover support -9-

Note: Align components before bolting them so that the gap size is equal all around

⇐ Reinstall securing eyes -5-, -6- and -7-

⇐ Reinstall securing eye -4- and 2 bolts -3

⇐ Reinstall bolts -1- and -2-

- Reinstall lock carrier mounting
- Reinstall D-pillar trim
- Reinstall roof end strip

1

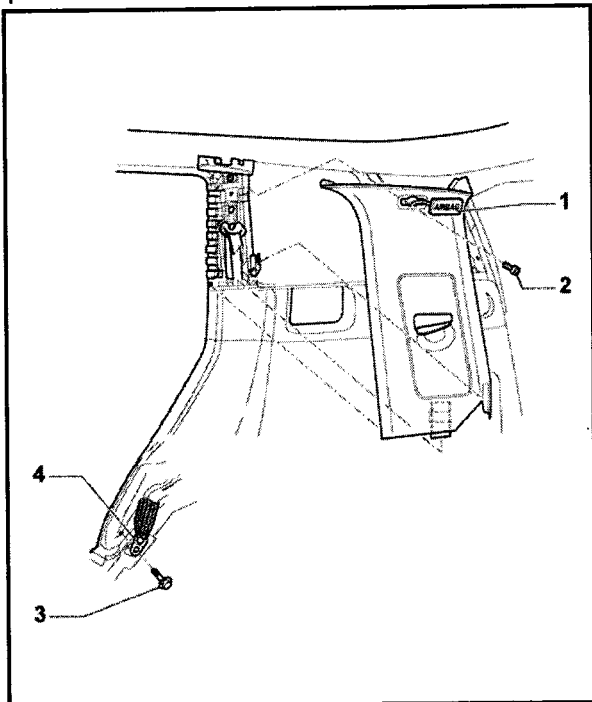

- Pull seat belt through opening and reinstall trim into mountings in body and door seal molding

Note: When installing trim, do not press belt height adjustment button
During installation, attach trim from bottom upwards towards belt height adjuster

⇐ Position seat belt anchor -4- on body and secure with bolt -3- and tighten to 50 Nm (37 ft. lbs.)

⇐ Secure trim with screw -2- and cover with air bag emblem -1-

- Reconnect batteries and tighten bolts to 9 Nm (80 in. lbs.)
- Perform battery restoration procedure
- Properly identify removed part(s) and store in a secure location at your dealership until directed otherwise.