



This Service Information bulletin supercedes S.I. B52 02 04 dated **January 2005**.

PERFORM THE PROCEDURE OUTLINED IN THIS SERVICE INFORMATION ON ALL AFFECTED VEHICLES BEFORE CUSTOMER DELIVERY OR THE NEXT TIME THEY ARE IN THE SHOP FOR MAINTENANCE OR REPAIRS.

Under the National Traffic and Motor Vehicle Safety Act of 1966, as amended, if there has been a recall campaign, dealers must assure that all new vehicles and new items of replacement equipment are free of safety defects and comply with all applicable Federal Motor Vehicle Safety Standards at the time of delivery to the consumer. This means that dealers may not deliver new motor vehicles or new items of replacement equipment to consumers unless the safety defect or noncompliance has been remedied before delivery.

 designates changes to this revision

SUBJECT

Recall Campaign 04V-575: Modification of the Front Seat Heater Circuit

MODEL

E60 (5 Series)

E65 (7 Series)

E66 (7 Series)

SITUATION

Mechanical loads exerted on the backrest heating for the front seats when persons get into or out of the vehicle may result in damage to the wiring of the outer side-bolsters in the heated backrest padding. A break in the wiring of the heated backrest causes the damaged area to overheat to unacceptable levels when the seat heating is switched on.

Copies of the customer notification letters and Q & A are attached.

To minimize customer's inconvenience caused by this Recall Campaign, you are being asked to pick-up (and deliver after repair) the affected vehicle from customer's home, and provide appropriate alternative transportation.

Customers will be impressed when you return their cars cleaned inside and out and with a full tank of gas. Reimbursement information for the vehicle fueling and valet costs can be found in the Warranty portion of this bulletin.

AFFECTED VEHICLES

This Recall Campaign involves E60 (5 Series) produced from June 17, 2003 until April 30, 2004 and E65/E66 (7 Series) produced from February 26, 2003 until June 9, 2004 with heated sport seats or heated basic seats.

In order to determine if a specific vehicle is affected by this Recall Campaign, it will be necessary to utilize the "Service Menu" of the DCS (Dealer Communication System). Based on the response of the system, either proceed with the corrective action or take no further action.

PROCEDURE

Before beginning repair of the seat backrest wiring it is necessary to inspect the part label attached to the seat heating wiring harness on both front seats.

1. Connect battery charger to the vehicle.
2. Remove both front seat backrest panels.

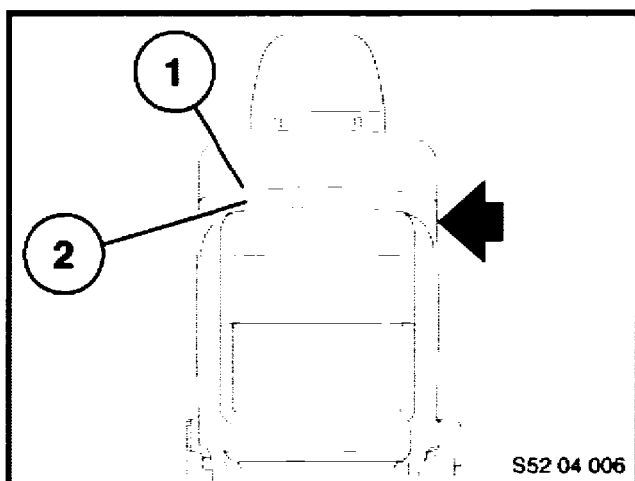

To remove the backrest panel, reach between the backrest panel and the cover in area (1) until you can feel clip (2). Pull the backrest panel to the rear slightly. With your other hand, strike the side of the backrest panel (as indicated by the arrow) from the inboard side of the seat. The clip on the door side is then released from the catch.

Note: Drivers seat shown.

3. Reach into the gap between the backrest panel and the cover until you can feel the clip on the inboard side. Pull the backrest panel slightly to the rear.
4. Once the two upper clips have been released from their catch, detach the entire rear backrest panel from the seat frame.

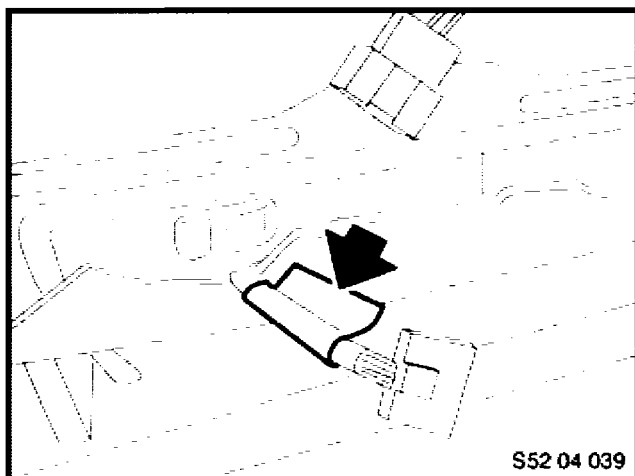

5. As indicated by the arrow, check the part number label attached to the seat heating wiring harness. Proceed with the repair **only** if the numbers and color combinations on the label match the data in the table shown below. No repair is necessary if this information **does not** match the data in the table shown below. Reassemble the vehicle.

Model	Part Number	KND Index	Color of Label
-------	-------------	-----------	----------------

E65/E66	7 110 194	00, 01, 02, 000, 001, 002	White
E65/E66	7 131 564	001	White
E60	7 065 837	002, 003, 005	White
E60	7 065 837	004	Green
E60	7 065 841	001, 002, 003, 004, 005	White

Note: If no label is found attached to the seat heating wiring, it is necessary to proceed with the repair.

Repair the backrest heating:

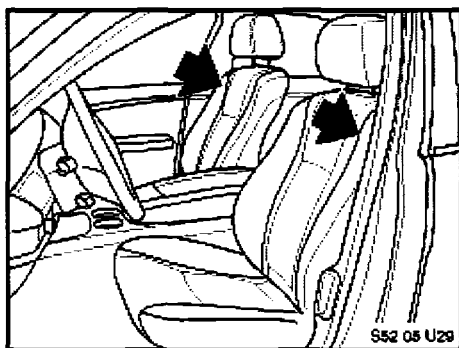

Note: This repair will be performed on the heating elements located on the outboard side of the front seats.

1. Adjust the seat to the most forward position.
2. Remove the door side seat switch trim on the front seat.

2a. E60 (5 Series) Front Seat:

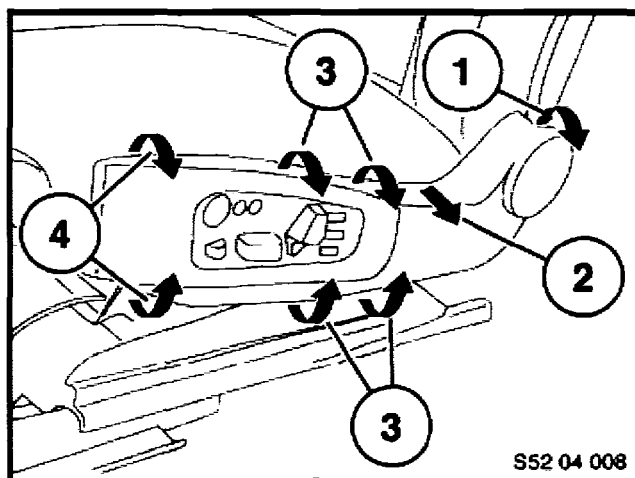

Unclip the trim at the sides (1) to the rear, pull it upwards, then pull the belt opening to the side (2). Gently bend open the trim at the top and bottom of the control unit (3). Gently bend open the top and bottom of the front trim (4) and pull it slightly outwards.

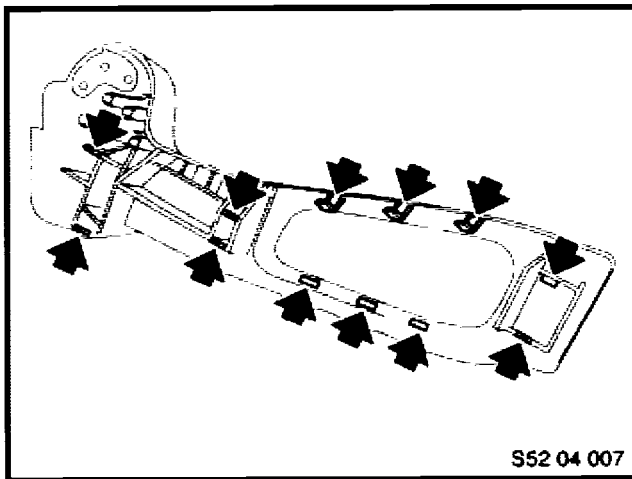

Note:
For correct installation, the retaining clips must not be damaged.

2b. E65/E66 (7 Series) Front Seat:

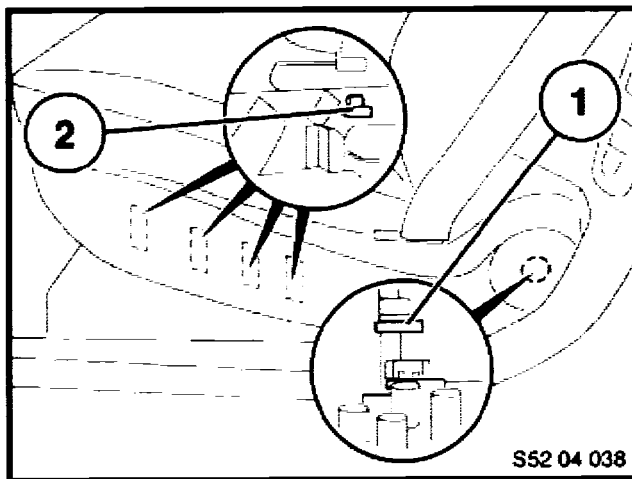

Detach the cover from the retaining clip (1).
Release the lugs by pushing downwards (2).

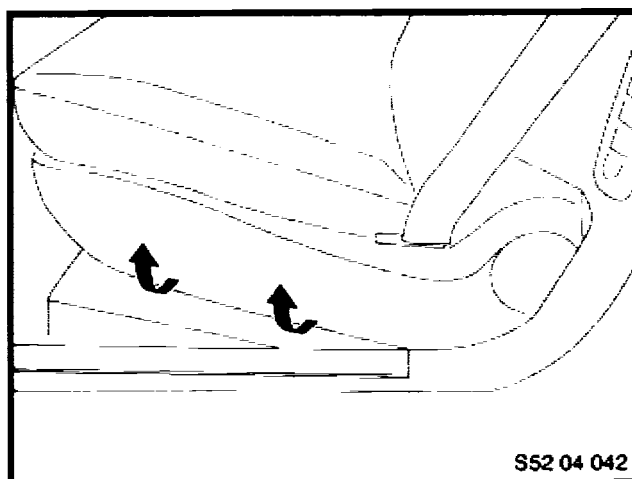

Lift the seat cover from below and remove it.

3. Remove the seat head restraint by following the proper repair instructions located in RA 52 ...

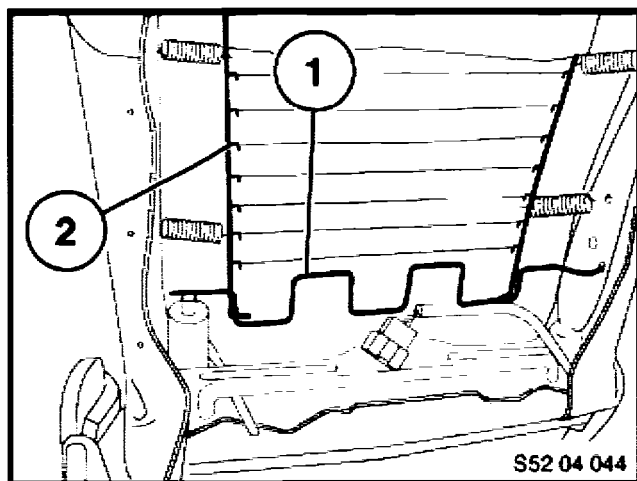

4. Draw the contour of the flexmat (2) and compression spring (1) on the door side with a suitable marker so proper fitment can be checked during installation.

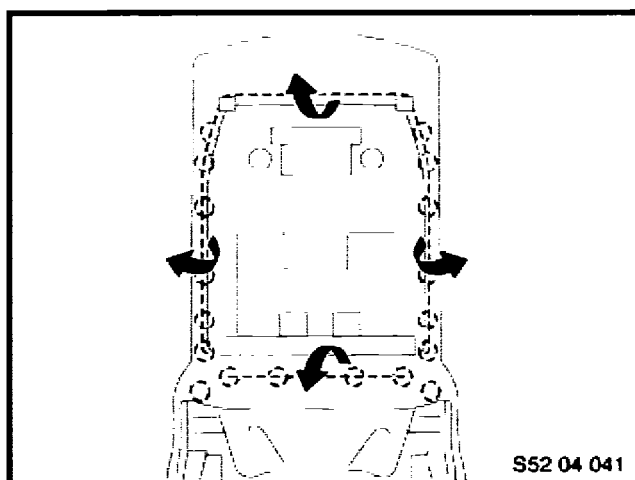

5. Using a regular screwdriver, bend open the securing hooks for the backrest cover (as indicated by the arrows).
6. Use upholstery pliers to pull the seat cover out of the securing hooks.
7. Remove the cotton fabric (if installed) from the securing hooks.

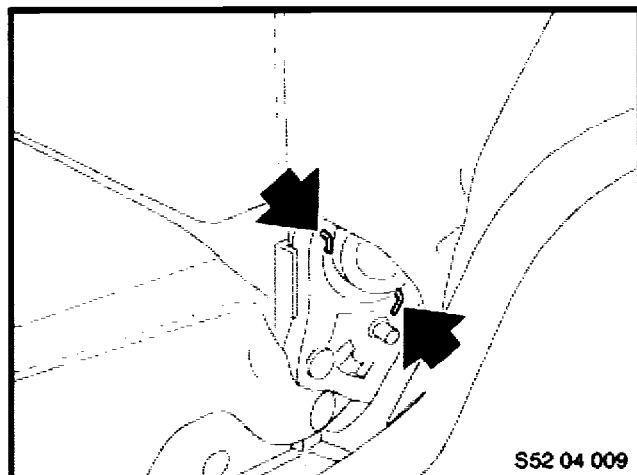

8. Unclip the door side backrest cover from the securing points at the bottom of the backrest (on the seat cushion).
 Note: It may be necessary to tilt the backrest backwards to bend open the securing hooks.

9. Disconnect the seat heating wiring harness connector.

10. Follow the applicable procedure:

A - For E60 (5 Series) Only

B - For E65/E66 (7 Series) Basic Seat Only

C - For E65/E66 (7 Series) Sport Seat Only

D - For All Seats

PROCEDURE A: E60 (5 SERIES) ONLY

1. Completely remove all the round latch clips from the foam and the flexmat. Remove all pieces of round latch clips, as these will cause rattling noises.

2. Loosen the foam with backrest cover from the backrest frame and fold it towards the center of the vehicle. The backrest cover remains attached at the bottom on the tunnel side. Removal without care could result in irreparable damage. The backrest heating wiring harness may be secured to the backrest frame by cable straps. These straps must be removed and replaced with new ones when the seat is reassembled.

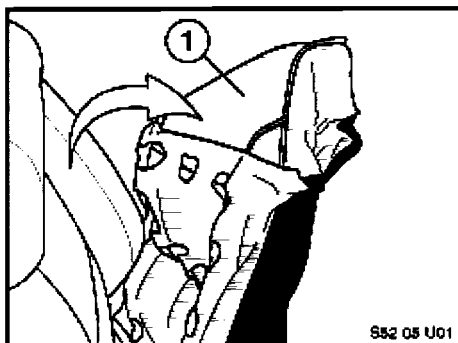

3. After removing all of the round latch clips, detach the backrest cover (1) from the foam pad. The cover will remain attached on the inboard side of the seat. Note: Passenger seat shown for the E60 (5 Series) repair.

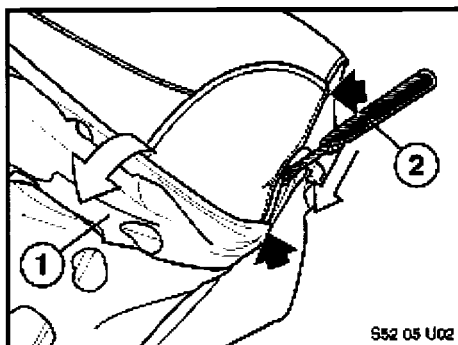

4. Fold down the cotton fabric (1) to gain access to the heating fleece. On the E60 (5 Series) Basic seat, it may be necessary to partially detach the heating fleece from the leather by cutting along the outboard seam using a seam ripper (2).

Note: Be careful not to cut the stitching that holds the leather seams together.

5. Fold the heating fleece (1) over to gain access to the

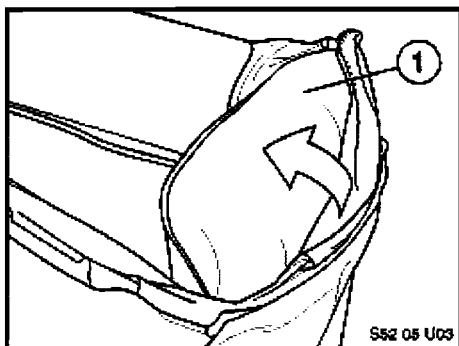

opposite side.

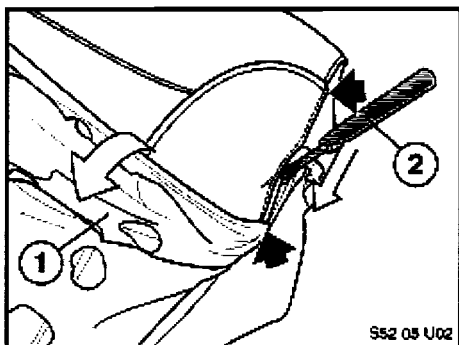

6. Mark the following dimensions on the heating fleece:

Note: Place a light behind the heating fleece to verify the location of the metal strands. Ensure that dimension A3 will completely cross the metal strands.

A1: approximately 60 mm (from the upper seam).

A2: approximately 30 mm for a basic seat or approximately 10 mm for a sports seat (from the door-side seam).

A3: approximately 20 mm (from dimension A2).

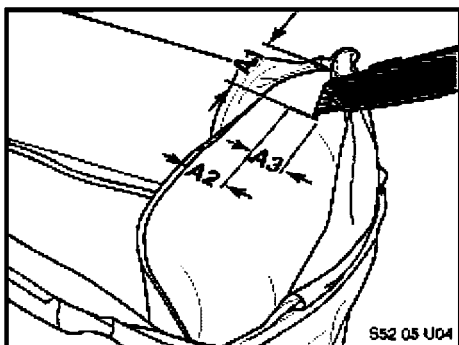

7. Cut open the heating pad along the marking made for dimension A3 to expose all 11 metal strands (1).

This cut can be made using a razor or a seam ripper.

Note: The heating fleece consists of 3 plies. Be careful when cutting along dimension A3 to only cut into the first ply. The metal strands are bonded to the second ply of the heating fleece.

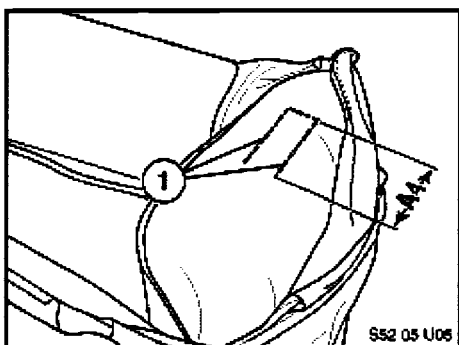

8. From the corners of the cut made for dimension A3, cut parallel incisions (1) to the left and right of the metal strands (A4) using a seam ripper.

Note: Place a light behind the heating pad to verify the location of the metal strands. Be careful when cutting along dimension A4 to only cut into the first ply.

A4: approximately 50 mm long.

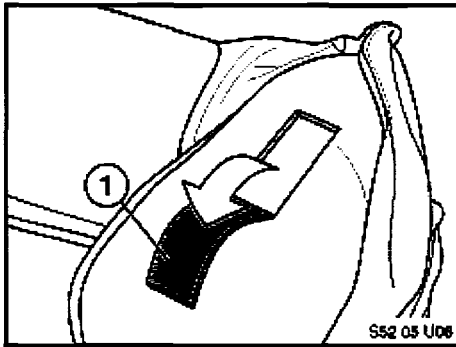

9. Peel back the first ply (1) of the heating fleece 50 mm to expose the metal strands.

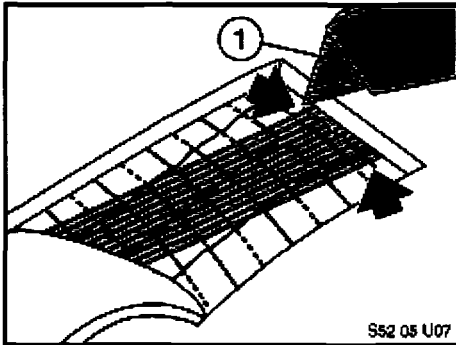

10. Use a razor (1) or a seam ripper to cut across the 11 strands by following the same cut made for dimension A3.

Note: A splice into these metal strands will be performed in a later step. Be sure this splice will connect to the wiring going downwards through the seat.

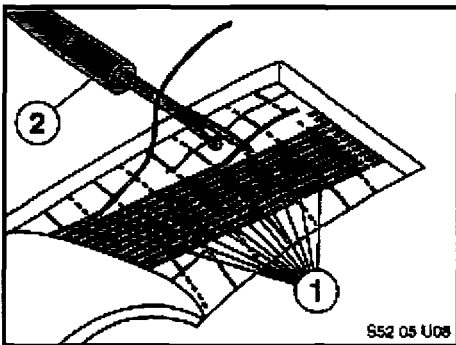

11. Using the blunt side of the seam ripper (2), carefully pull up on each metal strand (1) to release them from the fabric threads. Start pulling up on the metal strands near the cut made for dimension A3. Continue downwards until 50 mm of the metal strands have been released from the fabric threads.

Note: The metal strands remain attached to the fleece near the bottom fold of the first ply.

Be careful not to damage the metal strands when pulling them away from the threads. It may be necessary to cut some of the threads to release the metal strands.

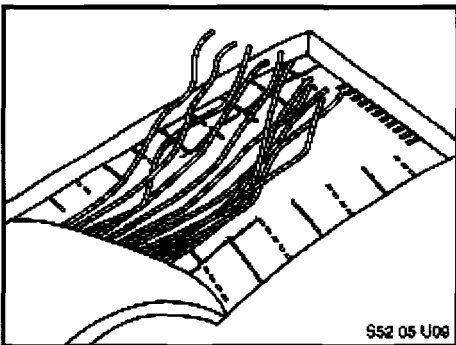

12. Once the 11 metal strands are released from the second ply of material, fan out the strands to make them ready to splice with the wire from the repair kit.

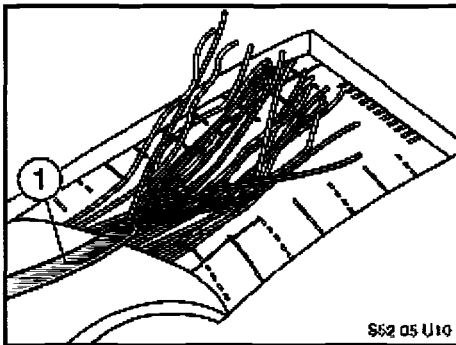

13. Strip the wire (1) from the repair kit (copper-colored end) and fan out the strands. Join the copper strands to the 11 metal heating strands and twist them together.

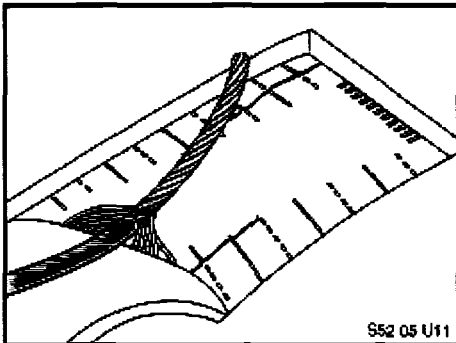

14. Twist the wires together tightly to form one slender splice of both sets of wires.

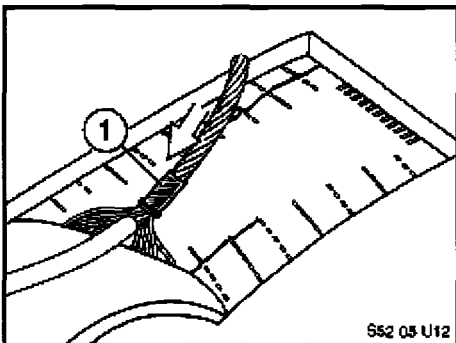

15. Push the end sleeve (1), from the repair kit, over the twisted splice.
Note: Push the larger diameter of the end sleeve over the strands first.

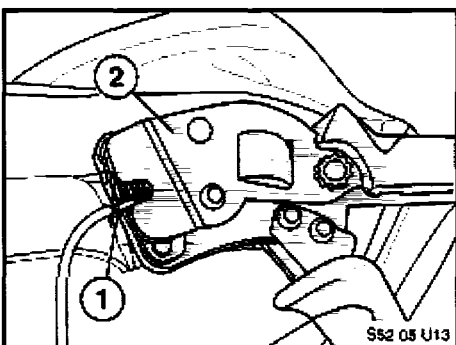

16. Crimp (1) using special tool (2) number 52 0 100. Cut off the protruding strands approximately 5 mm from the end of the sleeve.

17.  Cut and remove the second ply of the heating fleece by following the edges of the cuts made for dimensions A3 and A4.

 18. Affix the small fleece adhesive strip (1) (60

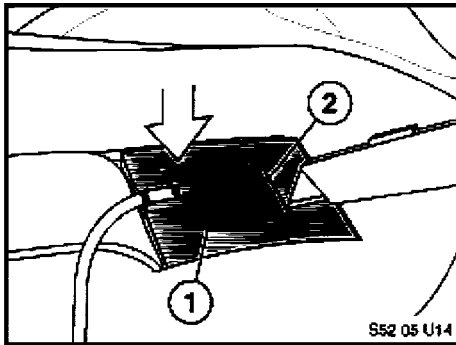

mm x 40 mm), from the repair kit, over the padding where the cuts were made.

19. Make a 10 mm cut (2) across the center of the installed fleece strip to make it possible to route the wire through at a later stage.

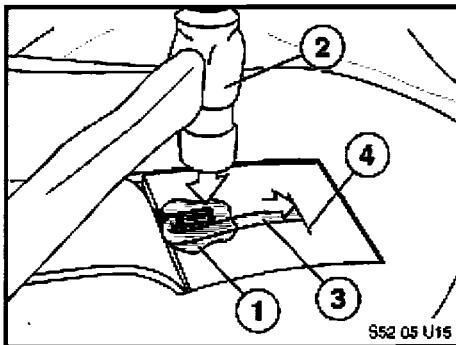

20. Using a hot glue gun, apply glue to the center of the small fleece adhesive strip (1) and affix crimped strands to the glue.

To secure, press a hammer (2) onto glue for at least one minute. Pull the wire (3) through the cut prepared in step 19 (4). Cut a small hole on the opposite side of the fleece padding to route the wire through.

Note: Do not use an excessive amount of glue and be sure to press firmly with the hammer. Failure to do so may result in a bump in the leather when the procedure is completed.

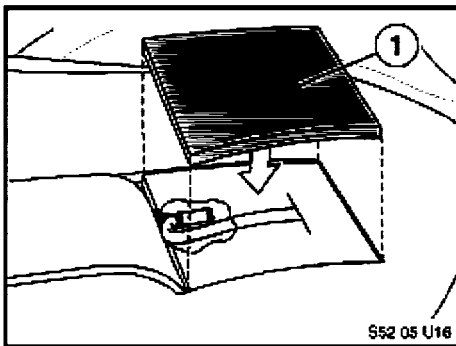

21. Affix another small fleece adhesive strip (60 mm x 40 mm) (1) over the repair area under the U-section.

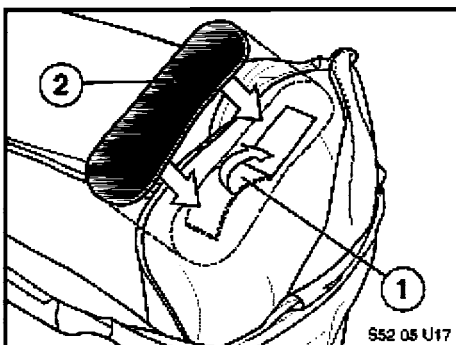

22. Fold the first ply (1) of the heating fleece back over the repair area and seal the repair area with the large fleece adhesive strip (170 mm x 55 mm) (2) provided in the repair kit.

23. Continue to procedure D: **For All Seats.**

PROCEDURE B: E65/E66 (7 SERIES) BASIC SEAT ONLY

1. Removal of seat cover from foam backrest pad.

Completely disconnect the seat cover from all of the metal hooks on the back side of the metal seat frame. Once they are all unhooked, pull the bottom of the seat cover towards the front of the vehicle to provide more slack at the top. Then, while leaving the seat cover attached to the foam pad, lift the seat cover and foam pad together up and over the backrest frame. Once the seat cover and foam pad are removed from the backrest frame, separate the cover from the foam by pushing down to compress the foam and then flip the seat cover forwards, over the top of the foam backrest pad.

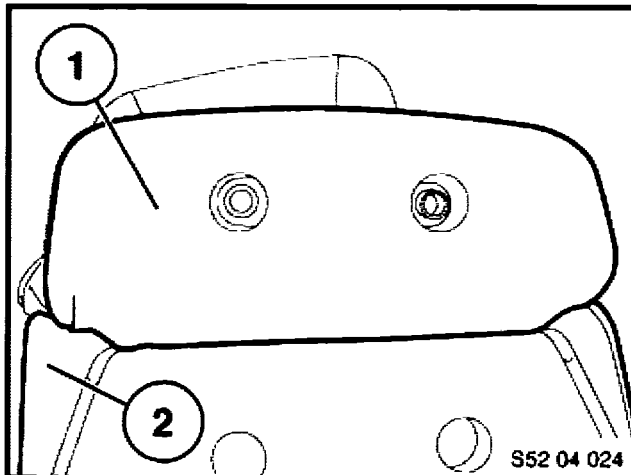

2. Fold the top portion of the seat cover (1) forwards, away from the foam backrest pad (2).

Note: Drivers seat shown.

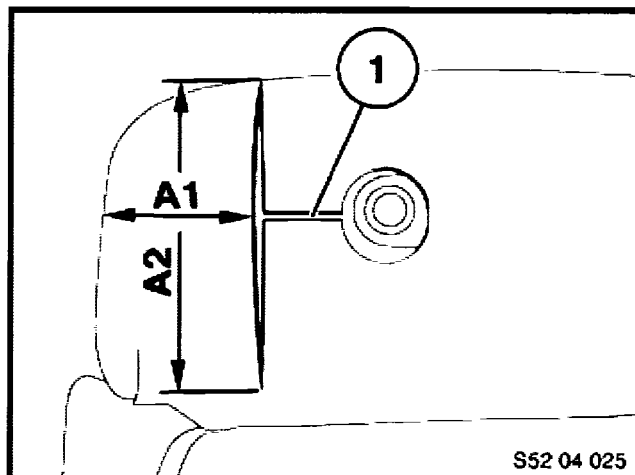

3. Mark the following dimensions on the cloth material of the seat cover (1).

A1: approximately 70 mm (from the door side seam to level with the middle of the head restraint hole).

A2: approximately 150 mm (from the upper edge of the cotton fabric).

Note: drivers seat shown for this procedure.

4. Using a seam ripper, cut the cotton fabric open along the marking (dimension A2). Make incision (1) in the same way.

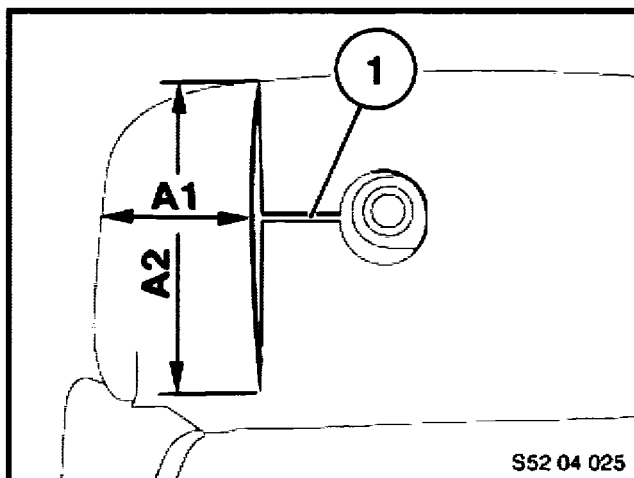

5. Turn the cotton fabric over and expose the padding.

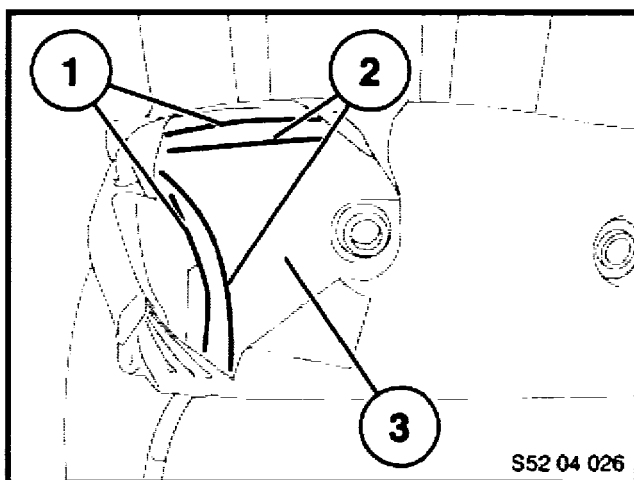

6. Draw guide lines (2) on the door side approximately 20 mm from seams (1) on padding (3).

7. Cut into the guide lines and fold the padding to one side. Cut into the padding carefully to avoid damage to the backrest heating.

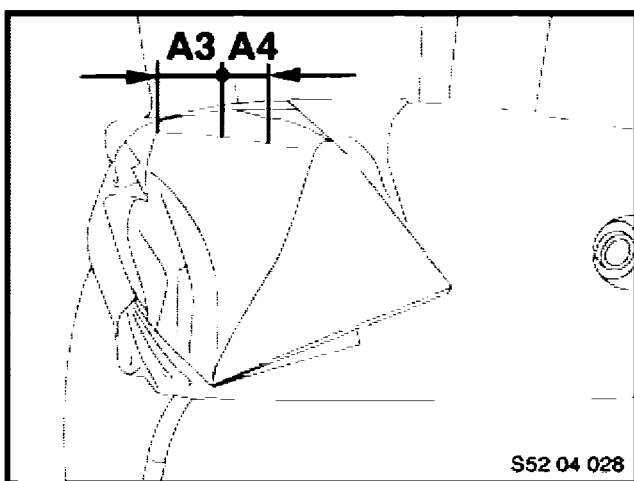

8. Mark the following dimensions on the backrest heating pad:
 A3: approximately 30 mm (from the start of the backrest heating pad on the door side).
 A4: approximately 30 mm (from dimension A3).

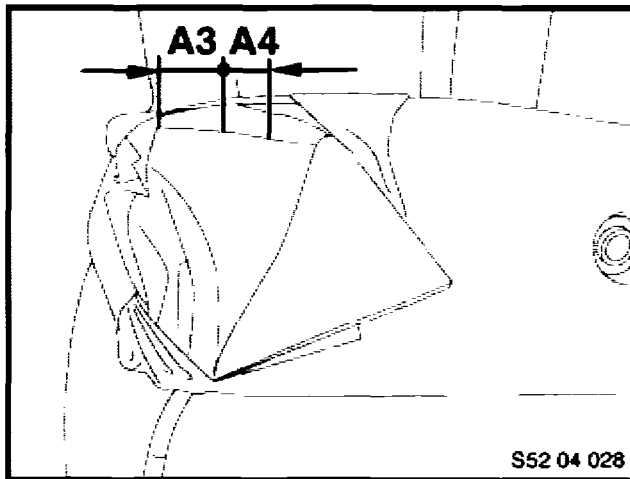

9. Cut open the backrest heating pad along the length of the marking (dimension A4) to expose all 11 metal strands, widen the cut if necessary. Note: Cut into the backrest heating carefully to avoid damage to the cover surface material.

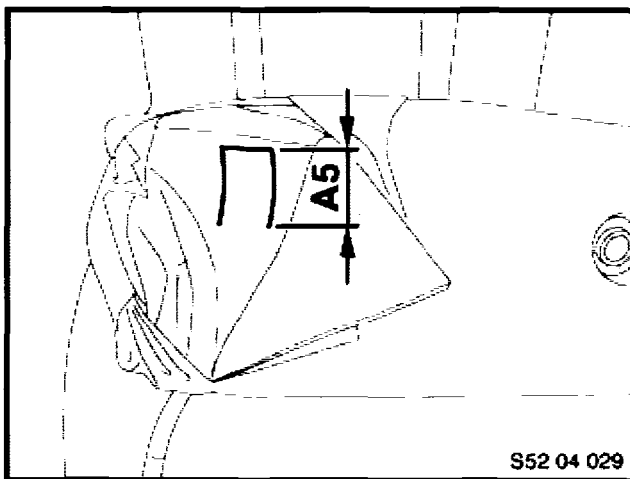

10. From the corners of the cut made above, cut parallel incisions to the left and right of the metal strands. Note: Be careful when cutting along dimension A4 to only cut into the first ply. A4: approximately 50 mm long. A5: approximately 40 mm long.

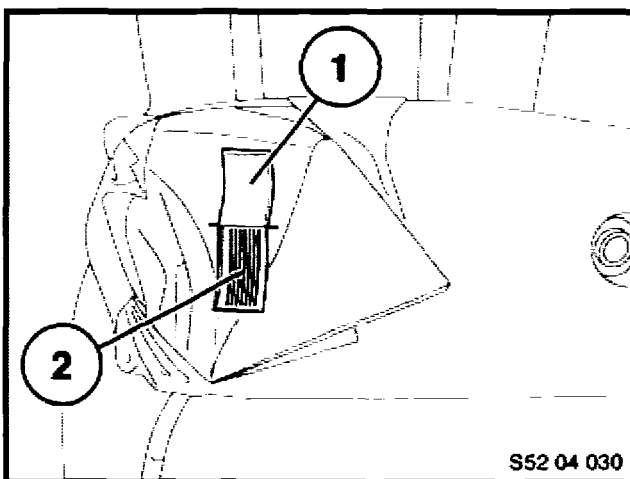

11. Peel back the first ply of the heating pad (1) to expose the metal strands (2).

12. Carefully pull up on each metal strand (1), using the blunt side of the seam ripper (2), to release them from the fabric threads. Start pulling up on the metal strands near the cut made for

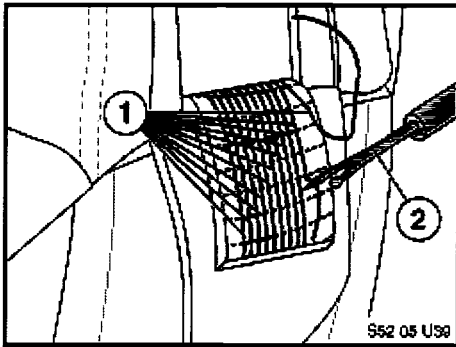

dimension A4. Continue until at least 30 mm of each of the metal strands has been released from the fabric threads.

Note: The metal strands remain attached to the fleece near the bottom fold of the first ply.

Be careful not to damage the metal strands when pulling them away from the threads. It may be necessary to cut some of the threads to release the metal strands.

Note: Illustrations in steps 12 through 19 are shown of the passenger side seat.

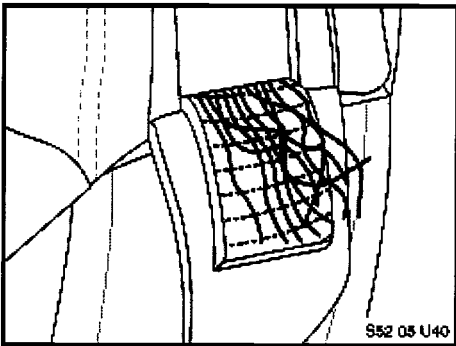

13. Once the 11 metal strands are released from the material, fan out the strands to make them ready to splice with the wire from the repair kit.

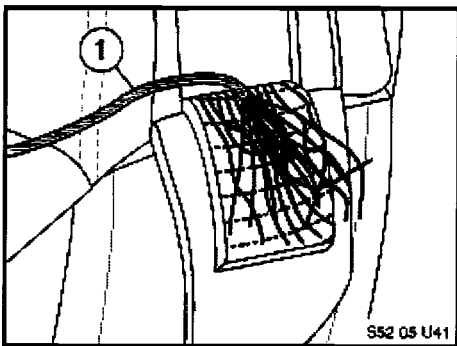

14. Strip the wire (1) from the repair kit (copper-colored end) and fan out the strands. Join the copper strands to the 11 metal heating strands and twist them together.

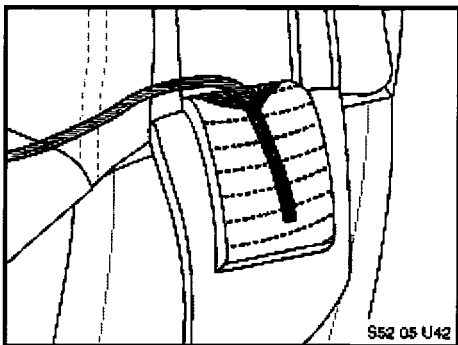

15. Twist the wires together tightly to form one slender splice of both sets of wires.

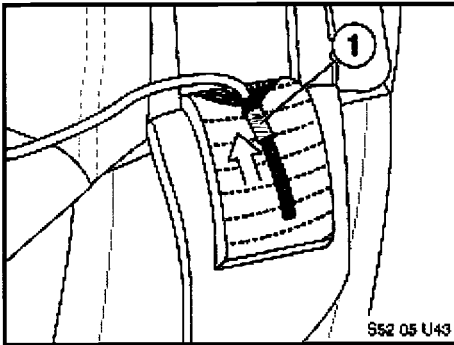

16. Push the crimp from the kit over the twisted strands with the larger diameter first.

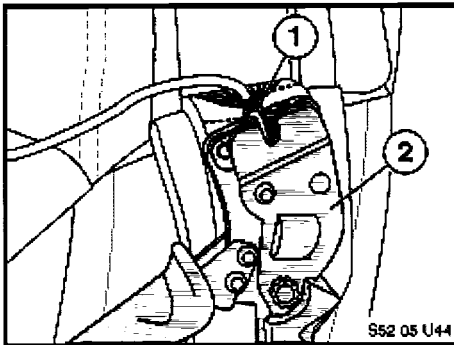

17. Crimp (1) using special tool (2) number 52 0 100. Cut off the protruding strands end of the sleeve.

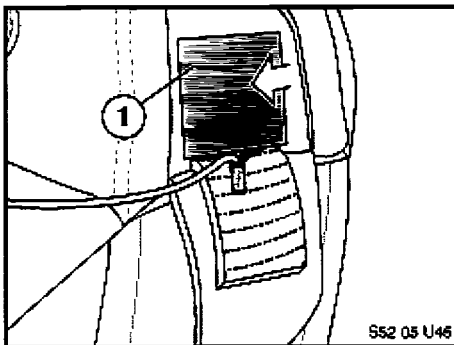

18. Affix the small fleece adhesive strip (1) (60 mm x 40 mm), from the repair kit over the padding where the cut was made.

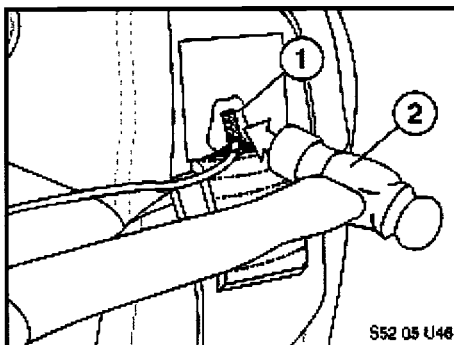

19. Using a hot glue gun, apply glue to small fleece adhesive strip (1) and affix crimped strands to the glue. To secure, press a hammer onto glue (2) for at least one minute.
Note: Do not use an excessive amount of glue and be sure to press firmly with the hammer. Failure to do so may result in a bump in the leather when the procedure is completed.

20. Fold the upper ply of the backrest heating pad (cover surface material side) back into the cutout. Affix the small fleece adhesive strip (60 mm x 40 mm) under the padding and over the cutout and upper ply of the backrest heating.

21. Fold the strand backing material and rear backrest heating ply onto the repair area.

22. Affix another small fleece adhesive strip (60 mm x 40 mm) to the repair area under the padding.

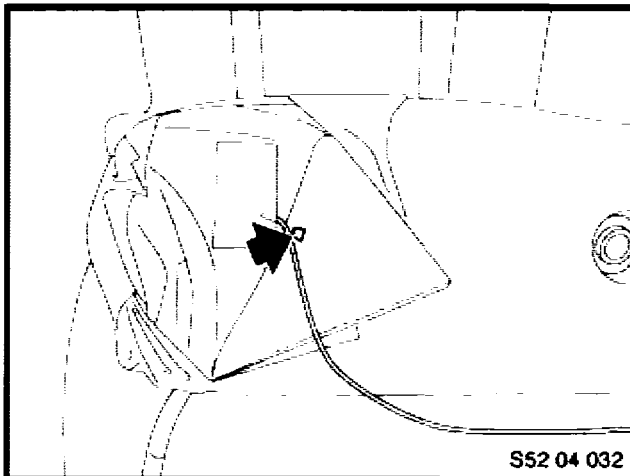

23. Cut a small hole into the padding near the new wire (as indicated by the arrow) and then pull the wire through loosely.

24. Fold back the padding and seal the incisions using a large fleece adhesive strip (170 mm x 55 mm).

25. Turn the cotton fabric over and affix using a large fleece adhesive strip (170 mm x 55 mm). Route the wire on the door side.

26. Continue to procedure D: **For All Seats.**

PROCEDURE C: E65/E66 (7 SERIES) SPORT SEAT ONLY

1. Removal of seat cover from foam backrest pad.

Completely disconnect the seat cover from all of the metal hooks on the back side of the metal seat frame. Once they are all unhooked, pull the bottom of the seat cover towards the front of the vehicle to provide more slack at the top. Then, while leaving the seat cover attached to the foam pad, lift the seat cover and foam pad together up and over the backrest frame. Once the seat cover and foam pad are removed from the backrest frame, separate the cover from the foam by pushing down to compress the foam and then flip the seat cover forwards, over the top of the foam backrest pad.

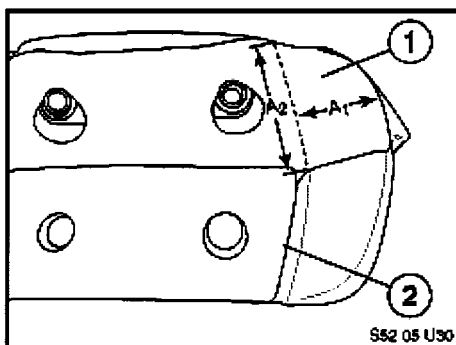

2. Fold the top portion of the seat cover (1) forwards, away from the foam backrest pad (2). Mark the following dimensions on the cloth material of the seat cover (1).

A1: approximately 70 mm (from the door side seam to level with the middle of the head restraint hole).

A2: approximately 150 mm (from the upper edge of the cotton fabric).

Note: passenger seat shown for this procedure.

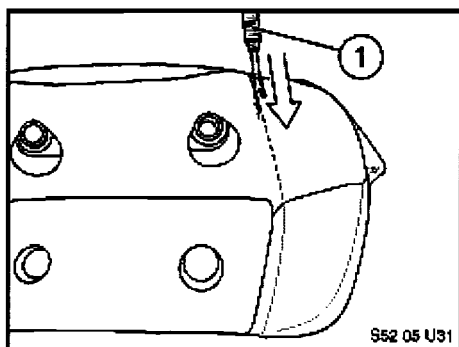

3. Using a seam ripper (1) cut the cloth material open along the marking (dimension A2).

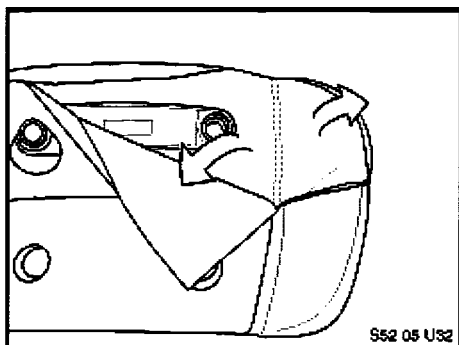

4. Turn the cloth material over to expose the padding.

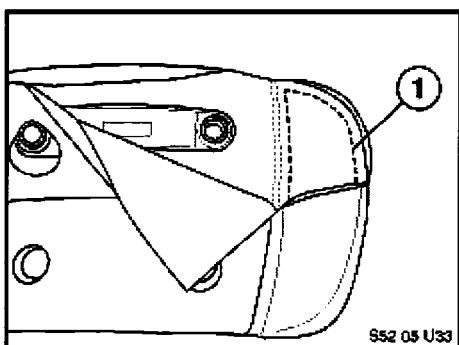

5. Draw guide lines (1) on the door side approximately 20 mm in from the seams on the padding. Then, using a seam ripper, cut along the guide lines into the fleece padding.

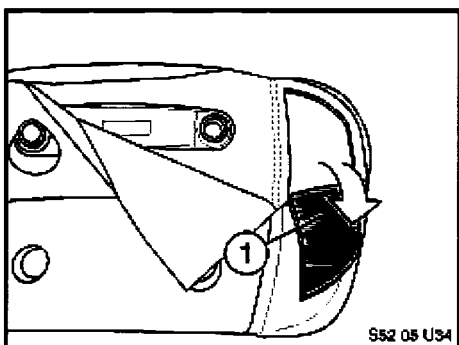

6. Fold down the fleece padding (1).
Note: The fleece padding remains attached at the bottom.

7. Draw a guide line (1) from the center of the head restraint hole across to the door-side seam.

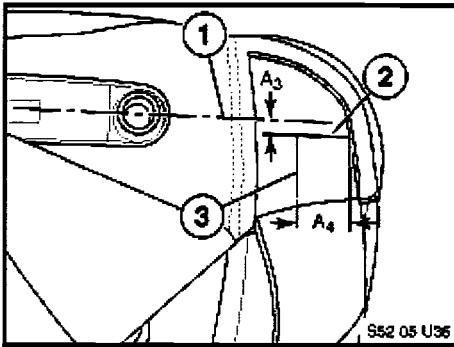

8. Below the guide line (1) made in step 7, draw a second guide line (2) approximately 10 mm below. A3: approximately 10 mm.

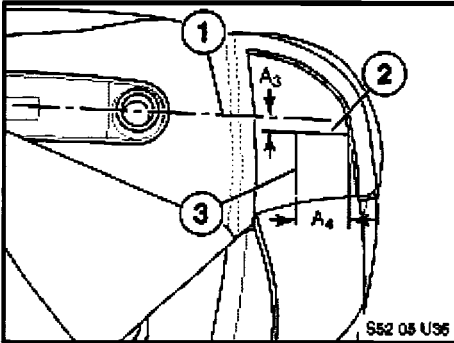

9. Mark dimension A4 from the door-side seam to guide line (3).

A4: approximately 30 mm

Note: When marking the line for dimensions A3 and A5, it is important to make sure the line stays to the outside of the 11 metal strands. The 11 metal strands can be identified by the grayish area located behind the fleece material. Also, it is important to note that the metal strands may not run at an exact 90 degree angle from the guide line (2).

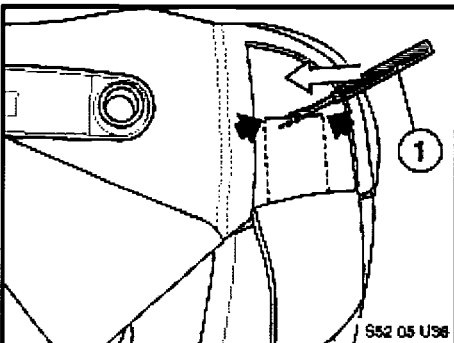

10. Using a seam ripper, carefully cut open the backrest heating pad along the marking (dimension A4) to expose all 11 metal strands. Widen the cut if necessary.

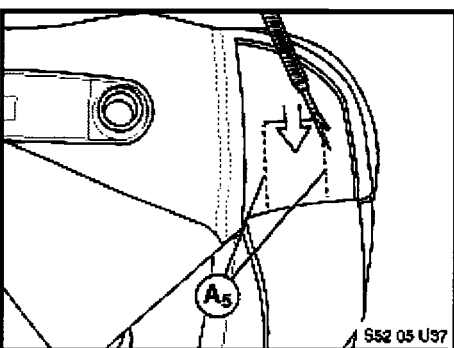

11. Cut parallel incisions (at a distance of 10 mm) to the left and right of the metal strands. Only cut into the first ply of the heating pad.

A5: approx. 40 mm.

Note: When marking the line for dimensions A3 and A5, it is important to make sure the line stays to the outside of the 11 metal strands. The 11 metal strands can be identified by the grayish area located behind the fleece material. Also, it is important to note that the metal strands may not run at an exact 90 degree angle from the guide line (2).

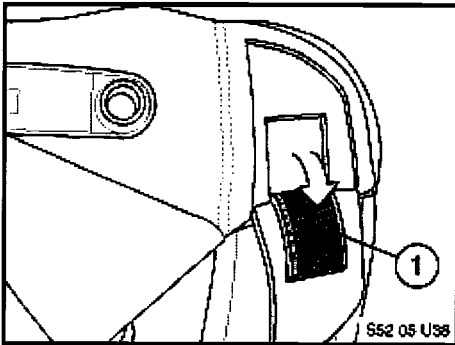

12. Peel back the first ply of the heating pad to expose the metal strands (1).

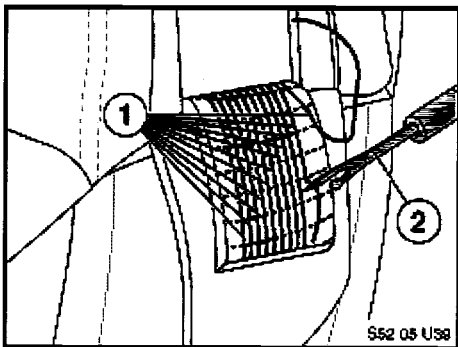

13. Carefully pull up on each metal strand (1), using the blunt side of the seam ripper (2), to release them from the fabric threads. Start pulling up on the metal strands near the cut made for dimension A4. Continue until at least 30 mm of each of the metal strands has been released from the fabric threads.

Note: The metal strands remain attached to the fleece near the bottom fold of the first ply.

Be careful not to damage the metal strands when pulling them away from the threads. It may be necessary to cut some of the threads to release the metal strands.

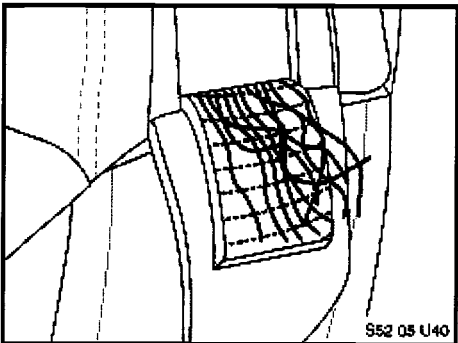

14. Once the 11 metal strands are released from the material, fan out the strands to make them ready to splice with the wire from the repair kit.

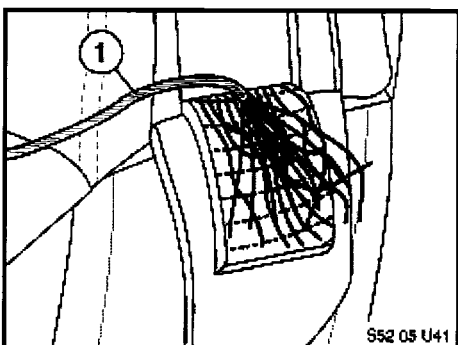

15. Strip the wire (1) from the repair kit (copper-colored end) and fan out the strands. Join the copper strands to the 11 metal heating strands and twist them together.

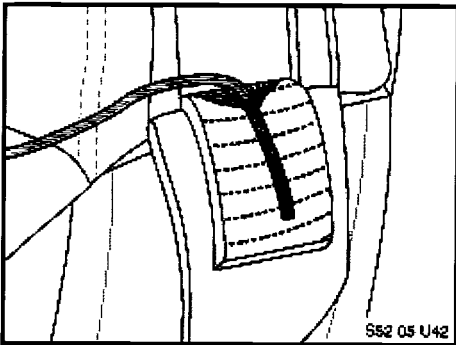

16. Twist the wires together tightly to form one slender splice of both sets of wires.

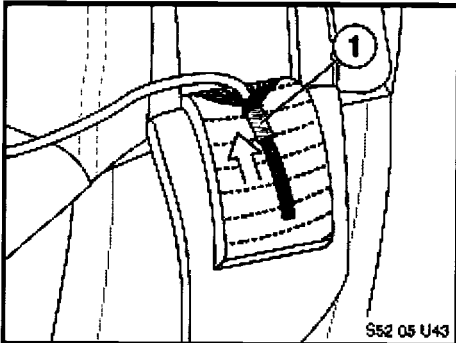

17. Push the crimp from the kit over the twisted strands with the larger diameter first.

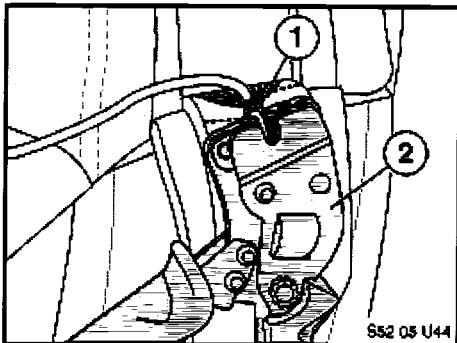

18. Crimp (1) using special tool (2) number 52 0 100. Cut off the protruding strands end of the sleeve.

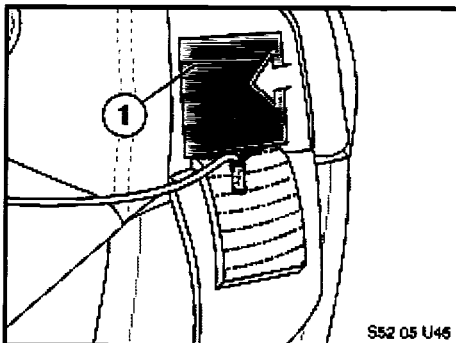

19. Affix the small fleece adhesive strip (1) (60 mm x 40 mm), from the repair kit over the padding where the cut was made.

20. Using a hot glue gun, apply glue to small fleece adhesive strip (1) and affix crimped strands to the glue.

To secure, press a hammer onto glue (2) for at least

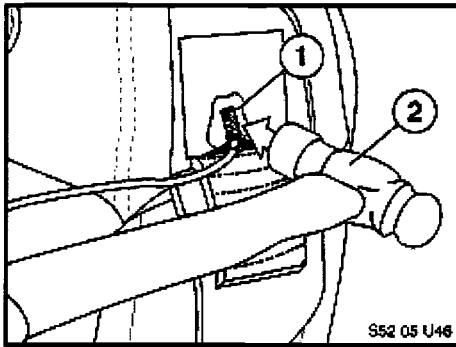

one minute.
 Note: Do not use an excessive amount of glue and be sure to press firmly with the hammer. Failure to do so may result in a bump in the leather when the procedure is completed.

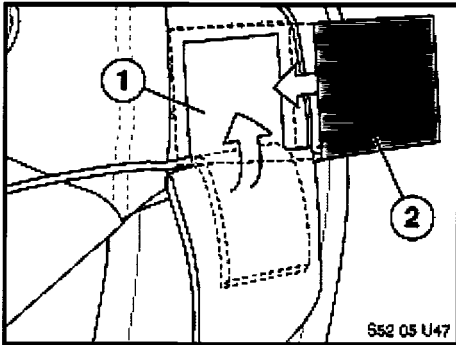

21. Fold up the first ply of the backrest heating pad (1) over the cutout. Affix another small fleece adhesive strip (2) from the kit over the cutout and the backrest heating ply.

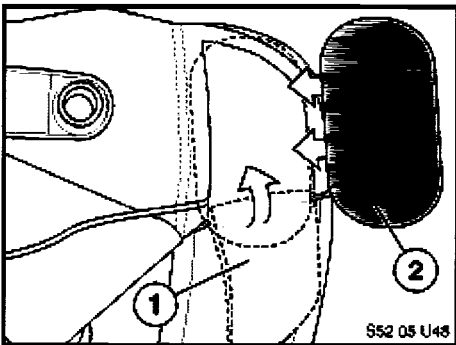

22. Turn the fleece padding (1) up and affix using the large fleece adhesive strip (2) from the kit over the top of it. Route the blue wire loosely on the door side of the seat.
 Note: It may be necessary to trim the large fleece adhesive strip.

23. Continue to procedure D: **For All Seats.**

PROCEDURE D: FOR ALL SEATS

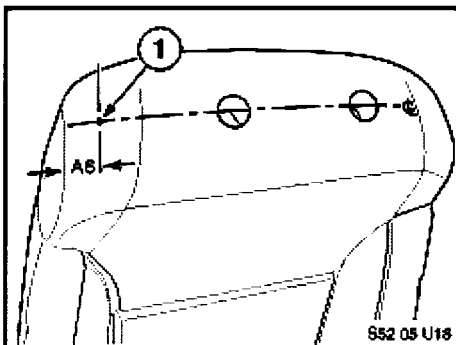

1. Fold door side backrest cover forwards and mark front foam pad (1) at the center of the head restraint holes and at a distance equal to dimension A6 from the edge.
 A6: approximately 30 mm.
 Note: Passenger seat shown for this repair procedure.

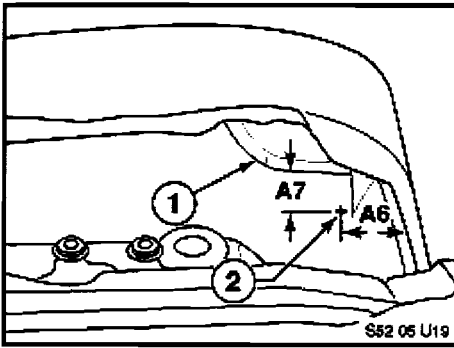

2. Mark (2) the rear side of the foam pad at a distance equal to dimension A7 from the edge of the lower molding contour (1) on the back of the foam pad and mark (2) at a distance equal to dimension A6 from the door side edge.

A6: approximately 40 mm.

A7: approximately 30 mm.

Note: View is shown while sitting in the back seat.

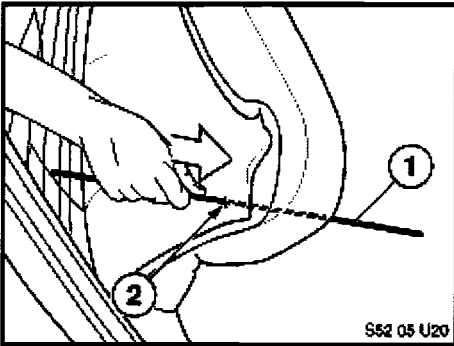

3. Push welding rod (1.5 - 2.5 mm²) (1) up through the two markings from the rear side of the foam pad (2).

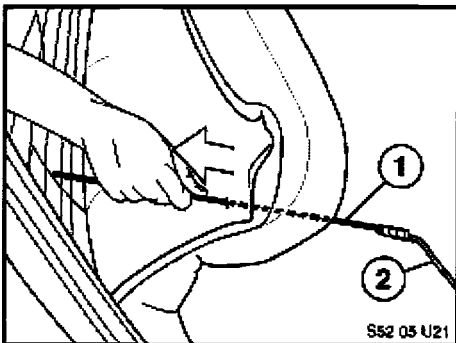

4. Bend upper section of welding rod (1) into a small loop and fasten the wire (2) to it. Pull the wire and welding rod through the foam pad blue end first.

Note: Route the blue wire loosely to the front of the foam pad.

5. Reassemble the lower half of the seat cover onto the foam backrest using new round latch clips.

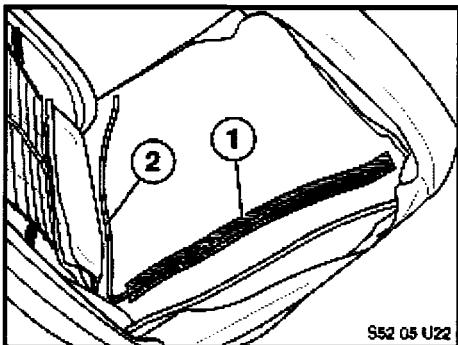

6. Affix long felt adhesive strip (500 mm x 40 mm) (1) to the outside edge in rear foam pad (above the line exit), secure blue wire to the center of long felt adhesive strip and route it downwards and towards the center of the seat (2).

Note: To avoid the risk of damage to the wire, affix the felt adhesive strip at a distance of at least 10 mm above the hole made in step 2.

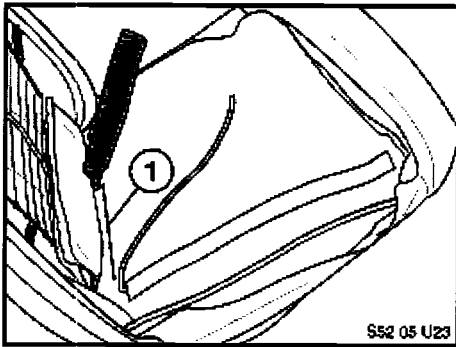

7. Cut a shallow incision (1) approximately 1/3 of the way across the bottom of the foam pad to be able to route the blue wire. Push the wire into the incision.
8. Affix a short felt adhesive strip (300 x 40 mm) over the length of the blue wire.

9. Fold the foam pad and seat cover over the backrest frame, but do not secure. Check that the foam pad and seat cover are positioned correctly.

10. Cut open the backrest heating wiring harness sheathing approximately 100 mm from the connector.

11. Gently secure the blue wire to the backrest heating wiring harness using electrical tape.

12. Connect blue wire (1) to backrest heating wiring harness (3) using a snap connector (2).

Driver seat wire color: Brown

Passenger seat wire color: Black and yellow

Notes for correct installation:

- Press the blue wire into the housing as far as the stop.
- Close the cover half and press together using suitable pliers until there is definite engagement. During this closing operation, make sure that the blue wire remains pressed into the stop.
- Route the other wire to be connected into the housing, close the cover half and press together using suitable pliers until there is definite engagement.
- The lines make proper contact when both housing halves are closed and engaged.

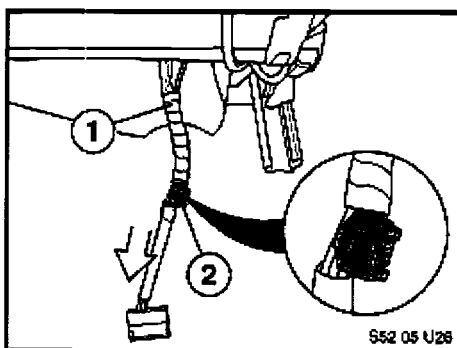
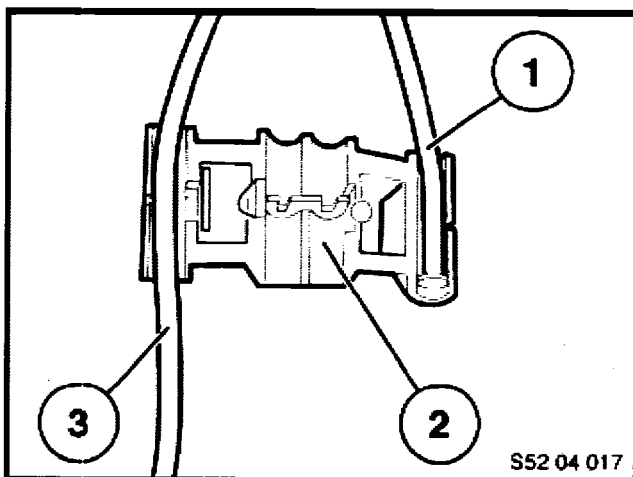

13. Wrap the blue wire and the wiring harness (1) with electrical tape up to the snap connector (2).

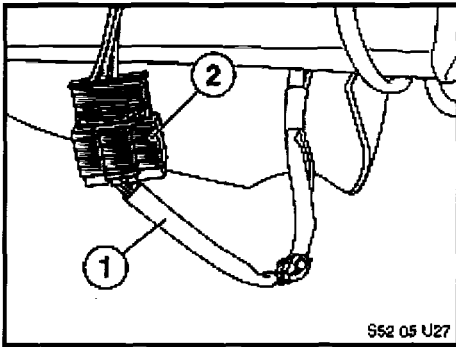

14. Connect the seat heater wiring harness (1) to the seat harness connector (2).

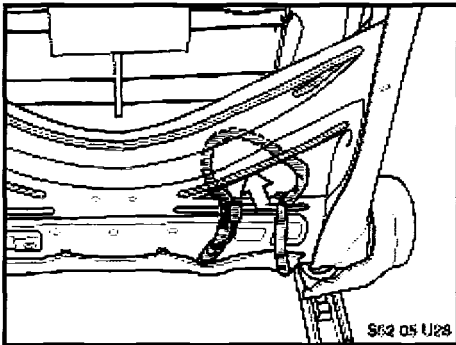

15. Insert the wiring connector's locking tab into the hole from the backside of the seat frame. Route wiring behind the backrest frame.

16. Carry out a function check. The ignition key must be turned to position 2 and the seat heating switched on for at least three minutes. The backrest must have heated up after this time.

17. Completely reassemble the seat.

Note: Perform the following to avoid damage to the corners of the leather when reinstalling seat cover over the foam backrest on the 7 Series seats:

Note: Pull up on the bottom of the seat cover to make more slack up top. Push down on the foam and flip the seat cover backwards onto the foam backrest. Then pull the seat cover and foam backrest together up and over the top of the metal backrest frame.

18. Repeat entire procedure on opposite front seat.

TOOL INFORMATION

All BMW Centers will automatically shipped 1 crimping tool.

Part Number	Description	Quantity
90 88 6 520 100	Crimping Tool (Automatically shipped)	1
N/A	Hammer (Typical shop item)	1
N/A	Glue Gun (Available at home improvement or craft stores)	1
N/A	Upholstery Pliers (Typical shop item)	1

N/A	Adjustable Pliers (Typical shop item)	1
N/A	Seam Ripper (Available at craft stores)	1

PARTS INFORMATION

All BMW Centers will receive an initial shipment of 20 seat repair kits through an automatic parts shipment. Additional kits can be ordered through regular part order.

Part Number	Description	Quantity
52 10 6 966 556	Seat Repair Kit	1
52 10 1 945 543	Round Latch Clips	As needed

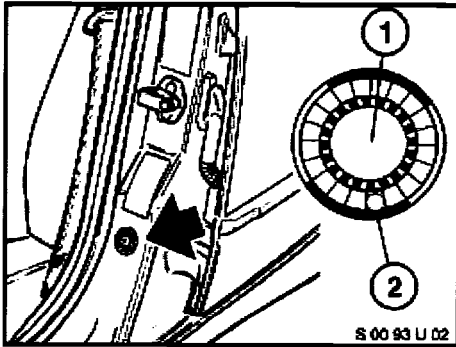
LABEL INSTRUCTIONS

This Recall Campaign has been assigned code number **432**. After the vehicle has been checked, and corrected if necessary, obtain a label (SD 92-267) and:

- emboss your BMW center warranty number in the middle of the label (1);
- punch out code number **432** (2) printed on the label and,
- affix the label to the **B** pillar as shown.

If the vehicle already has a label from a previous Service Action/Recall Campaign, affix the new label next to the old one. Do not affix one label on top of another one because a number from an underlying label could appear in the punched-out hole of the new label.

WARRANTY INFORMATION

Reimbursement for this Recall will be via Campaign Entry.

Defect Code	00 52 18 01 00	
Work Package #1	Check the seat heating design of both front seat backrests.	
Labor Operation:	00 55 177	
Labor Allowance:	5 FRU	
Parts Allowance:	N/A	Qty: 0
Work Package #2	Check the seat heating design of both front seat backrests and repair one seat heating circuitry.	
Labor Operation:	00 55 178	

Labor Allowance: 20 FRU
 Parts Allowance: Seat Heater Repair Kit Qty: 1
 Sublet Allowance: Round Latch Clips as needed Max: \$2.00
 Sublet Code: 4

Work Package #3 Check the seat heating of both front seat backrests and repair both seats heating circuitry.

Labor Operation: 00 55 179
 Labor Allowance: 36 FRU
 Parts Allowance: Seat Heater Repair Kit Qty: 1
 Sublet Allowance: Round Latch Clips as needed Max: \$2.00
 Sublet Code: 4

RE-FUELING COST

BMW of North America, LLC, will provide reimbursement to have the gas tank topped off once as required, for each vehicle affected by this Recall Campaign. Attach the appropriate receipt to the work order.

Defect Code 85 99 00 66 NA **Refuel E60 (5 Series) and E65/E66 (7 Series) affected by Recall 04V-575.**

Sublet: Actual cost to top off the fuel tank.

Sublet code: 4

VALET COST

BMW of North America, LLC, will provide reimbursement for vehicle valet services (pick up & delivery) for each vehicle affected by this Recall Campaign. Attach the appropriate receipt to the work order.

Defect Code 99 99 77 77 NA **Valet Service E60 (5 Series) and E65/E66 (7 Series) affected by Recall 04V-575.**

Sublet: \$25.00

Sublet code: 4

RENTAL VEHICLES

Service Loaner vehicles, for this recall, should be utilized for alternative transportation needs to promote customer satisfaction.

Retailers participating in the Retailer Administered Customer Assistance Program and the Service Loaner Car Program may self-authorize claims for reimbursement of rental costs from independent rental agencies in certain situations. For more details refer to SI B01 07 03.

[Copyright © 2005 BMW of North America, LLC]