

SUBJECT: RADIATOR UPPER HOSE REPLACEMENT			No.: 04V-542
			Date: DECEMBER 2004
			Models: 1996 EXPO
CIRCULAR A:	<input checked="" type="checkbox"/> GENERAL MANAGER	<input checked="" type="checkbox"/> PARTS MANAGER	<input checked="" type="checkbox"/> SHOP TÉCNICIAN
<input checked="" type="checkbox"/> SERVICE ADVISOR	<input checked="" type="checkbox"/> SERVICE MANAGER	<input checked="" type="checkbox"/> WARRANTY ANALIST	<input type="checkbox"/> GERENTE DE VENTAS

PURPOSE

This bulletin contains information concerning a Safety Recall related to a possible detaching condition of the radiator upper hose. The hose clamps installed may not secure the upper hose correctly, causing the detachment of the hose from the radiator connector due the engine behavior. In a worse case scenario, the hose may come out leading coolant leakage and subsequent heating of the engine.

AFFECTED VEHICLES

1996 Mitsubishi Expo: Produced between May 24, 1996 through July 15, 1996.

CUSTOMER NOTIFICATION

A notification letter will be mailed to owners of all potentially affected units, instructing them to take the vehicles to an authorized Mitsubishi Dealer to replace with a new radiator upper hose and hose locking clamps. A copy of the customer notification letter is enclosed at the end of this bulletin.

REQUIRED OPERATIONS

Before starting the **PROCEDURE** section of this bulletin, check the Warranty Superscreen to confirm that the unit to verify that the vehicle is an affected VIN for this campaign and that this campaign procedure has not already been completed.

This repair procedure includes the replacement of the radiator upper hose and both clamps (upper and lower) used to secure the hose in accordance to the procedure established in this bulletin.

 CAUTION
--

If the pressure in the interior of the radiator is high, previous to partially draining the coolant, loose the radiator cap to avoid getting scald. Put a damp cloth over the radiator cap.

Verify by placing a cloth over the hose and squeeze. If the hose feels soft, resume with the procedure, if it still hot wait until it cools.

PROCEDURE

NOTE: Although either the spring type clamps or the wire type clamps are used on the hose, replace the clamps with the new spring type (MR404538) provided in the kit.

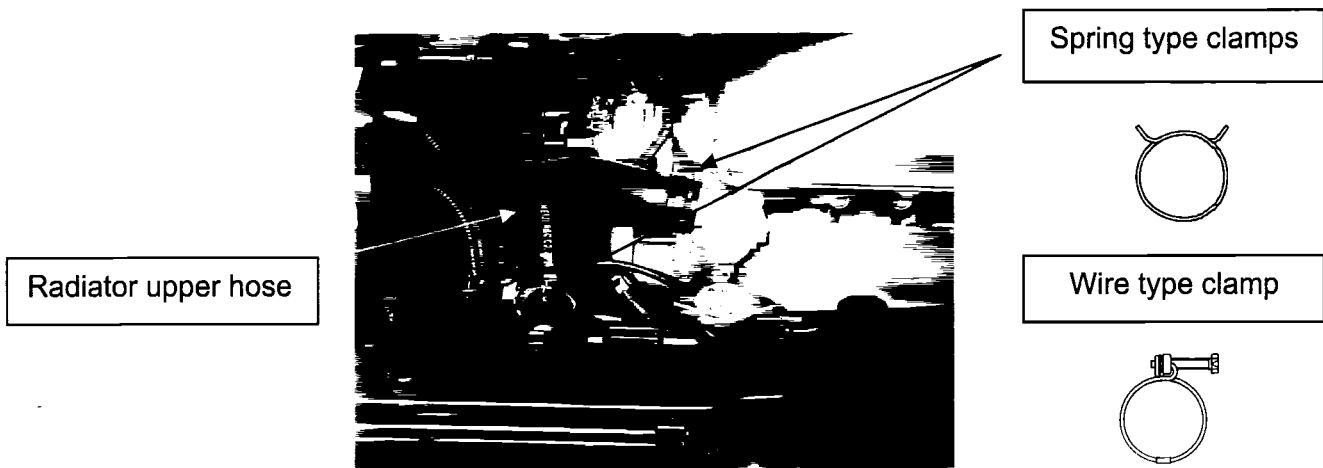

- 1- Open the radiator drain plug. Partially drain the coolant until the core is exposed. Close the drain plug. **Do not drain the radiator completely.**
- 2- Displace the upper hose radiator side clamp towards the center of the hose and detach from the radiator fitting.
- 3- Displace the upper hose engine side clamp towards the center of the hose and detach from its fitting. Remove the hose assembly.
- 4- Install both new spring type clamps on the sides of the new radiator hose and install as illustrated below.

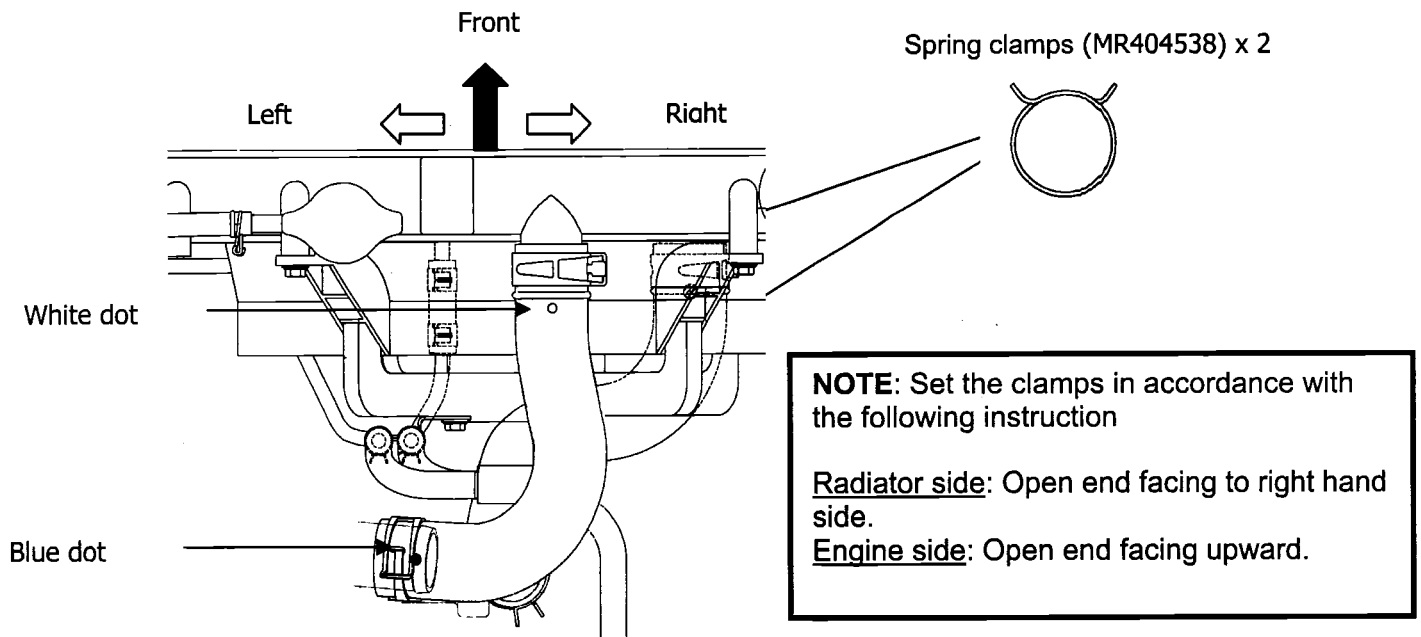

- 5- Complete the coolant level in the radiator and purge (bleeding air) from the radiator by leaving the engine running at idle speed for a few minutes. Add the required amount of coolant into the condenser tank, as necessary.
- 6- Wipe out the spilt coolant in the engine room and/or radiator area.

IDENTIFICATION

Apply white or yellow paint on the upper surface of radiator upper hose as ID mark.
See the illustration below

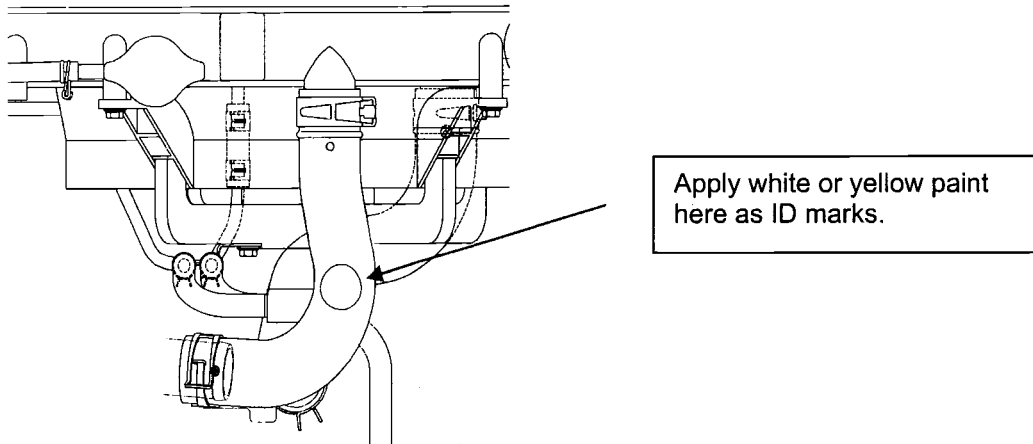

PARTS INFORMATION

Due to the small amount of vehicles in this recall, there will be no parts delivered by “forced allocation” to the dealers. All orders will be established in the Dealer Link Parts Ordering screen as established in the Parts Policies and Procedures.

Use the genuine Mitsubishi Parts listed below.

Description	Part Number	Quantity	Contents
Radiator Upper Hose Kit	MB890482C	1	MB890482 (Upper Hose) x 1 MR404538 (clamp: spring type) x 2

WARRANTY INFORMATION

Replacement of the Radiator Upper Hose and both securing clamps

Campaign Labor Operation No.: R3010911

Time Allowance: 0.4 hrs