



MITSUBISHI FUSO
TRUCK OF AMERICA. Inc.

2015 Center Square Road
Logan Township, NJ 08085
(856) 467-4500
(856) 467-4695 Fax

October 21, 2004

TO: Dealer Principal
Dealer Service Manager
Dealer Parts Manager

RE: **CAB LATCH LOCK INDICATOR RECALL S3026120 - 04V-437**
CAB TILT MAIN HOOK RECALL R3120420 - 04V-436
FRONT HUB BEARING FH-FK RECALL R3123510 - 04V-478
FRONT HUB BEARING FM RECALL C0021113 - 04V-477

MFTA has released the four recalls listed above. The details for each recall are outlined in the enclosed Recall Information Bulletins. Customer Notification Letters will be mailed to affected customers on October 25, 2004. We appreciate your assistance in performing the enclosed recall campaigns on all vehicles requiring the repairs.

Please be advised that Dealers are required by law to perform any safety recall assigned to a vehicle in Dealer inventory prior to the retail sale of that vehicle. Make every effort to ensure that all recalls on vehicles in your inventory are completed promptly. A listing of all vehicles in Dealer inventory, and all vehicles your Dealership has sold, can be found on the "Open Campaigns" report accessed through Fusonet.

There may be cases where customers have incurred costs for repairs addressed in these recalls. MFTA has requested that customers supply Dealers with copies of any paid invoices evidencing those costs. If any customer requests reimbursement, and provides appropriate documentation, please submit a warranty claim for the amount shown on the paid invoice(s) and fax the invoice(s) to MFTA Warranty at 856-467-8169 (referencing your Dealer Code and MFTA Claim #). MFTA will process the warranty claim for payment as soon as the back-up documents are received. Please reimburse your customer immediately after receiving notification of payment by MFTA Warranty.

Please contact your Field Service Manager or myself with any questions.

Sincerely,

A handwritten signature in black ink that reads "William P. Mohr".

William P. Mohr
Director, Service Operations

Enclosures



Recall Information Bulletin

No: C0021113 Issued: 10/21/2004

Re: Front Hub Bearing FM

Group: 26 Models: FM6

SUBJECT:

Safety Recall C0021113 - Front Hub Bearing FM

MODELS:

FM617, FM61F(FM260) and FM64F(FM260) - F060T Axle

FM657 and FM65F(FM330) - F070T Axle

VEHICLES INVOLVED:

Certain 2000-2005 model year FM617, FM61F(FM260), FM64F(FM260), FM657 and FM65F(FM330) vehicles produced from March 2000 through August 2004 equipped with an F060T or F070T front axle assembly

A list of vehicles your Dealership has sold that require this Recall can be found on the Dealer's "Open Campaigns" list supplied by MFTA via Fusonet. Some individual vehicles described above may not need the Recall. Always check the "VIN Inquiry" tab under "Service" or "Warranty" on Fusonet to verify that the VIN requires this Safety Recall.

OWNER NOTIFICATION:

Owners of affected vehicles will be notified by mail. A copy of the customer letter is included with this bulletin.

CONDITION:

MFTA has decided that a defect which relates to motor vehicle safety exists in the front hub bearings on certain vehicles. On affected vehicles, the front wheel hub outer bearing lock nut may have been improperly tightened during initial assembly, and an insufficient amount of grease may have been applied to the outer bearing. These conditions could result in the outer bearing generating excessive heat and/or breaking, causing the vehicle to become disabled. In the worst case, the excessive heat could cause a fire.

MODIFICATION:

The inner and outer front wheel hub bearings must be inspected and properly lubricated. Any bearing showing an abnormality will be replaced. **Please note: The outer hub bearing must be replaced any time an inner bearing is found to have an abnormality.**

USE THIS SECTION FOR FM617, FM61F(FM260) AND FM64F(FM260) VEHICLES EQUIPPED WITH AN F060T FRONT AXLE

PARTS TO BE REPLACED:

Install a new wheel hub oil seal and wheel hub gasket on all vehicles involved. Replace bearings only when signs of damage or abnormality are evident.

Replacement Parts		
Part Number	Description	Quantity
MH034086	Wheel hub oil seal	2
MK309841	Wheel hub gasket	2
MH043127	Outer hub bearing	0-2
MH043128	Inner hub bearing	0-2

RECALL CLAIM SUBMITTAL:

The two wheel hub oil seals, two hub cover gaskets, grease, solvent, labor and any damaged front hub bearings are reimbursed via the DIN System using the Recall Claim Entry screen. Enter all requested information, including the Recall Number. Choose a Recall Number from the Recall Reimbursement table on page two that corresponds with the actual parts replaced. The system will apply the labor allowance and parts pricing adjustment shown.

Recall Reimbursement					
Campaign Number	Allowances		Labor Description	Bearings	
		Labor Time			
C0021110	Labor Time	2.7 hours	Disassembly, cleaning, bearing inspection, seal & hub cap replacement and reassembly, no bearing replacement	None	
	Parts Pricing	\$44.24			
C0021120	Labor Time	3.1 hours	Disassembly, cleaning, bearing inspection, seal & hub cap replacement and replacement of one outer wheel bearing, zero inner wheel bearings	1	MH043127
	Parts Pricing	\$88.31		0	MH043128
C0021130	Labor Time	3.1 hours	Disassembly, cleaning, bearing inspection, seal & hub cap replacement and replacement of two outer wheel bearings, zero inner wheel bearings	2	MH043127
	Parts Pricing	\$132.38		0	MH043128
C0021140	Labor Time	4.5 hours	Disassembly, cleaning, bearing inspection, seal & hub cap replacement and replacement of one outer wheel bearing, one inner wheel bearing	1	MH043127
	Parts Pricing	\$155.01		1	MH043128
C0021150	Labor Time	4.5 hours	Disassembly, cleaning, bearing inspection, seal & hub cap replacement and replacement of two outer wheel bearings, one inner wheel bearing	2	MH043127
	Parts Pricing	\$199.08		1	MH043128
C0021160	Labor Time	4.5 hours	Disassembly, cleaning, bearing inspection, seal & hub cap replacement and replacement of two outer wheel bearings, two inner wheel bearing	2	MH043127
	Parts Pricing	\$265.78		2	MH043128
NOTE: See the Parts Pricing Adjustment table on the bottom of page 4 for reimbursement breakdown.					

RECALL PARTS RETENTION:

All bearings that have been removed and replaced must be properly identified and retained, as outlined in the Warranty and Service Policy Manual, section 3.8. The Field Service Manager will inspect each bearing and authorize its scrapping.

REPAIR PROCEDURES:

1. Park the vehicle, shut off the engine, apply the parking brake, and chock the rear wheels. Lift the front axle, install jack stands of sufficient capacity and slacken brake adjustment.

PERFORM THE FOLLOWING STEPS ON EACH FRONT WHEEL HUB:

2.

Remove and save the wheel hub cover. Properly position a wheel dolly under the wheel assembly. Remove the three lock ring mounting bolts (PHOTO 1) and lock ring. Remove the outer hub nut using the 70mm socket **MH061528**. Remove the lock plate and outer wheel hub bearing (PHOTO 2). Using the wheel dolly, remove the wheel, tire, drum and hub as an assembly.

or, in the absence of a wheel dolly:

Remove and save the wheel hub cover. Remove the wheel and tire assembly. Remove the three lock ring mounting bolts (PHOTO 1) and lock ring. Remove the outer hub nut using the 70mm socket **MH061528**. Remove the lock plate and outer wheel hub bearing (PHOTO 2). Remove the drum and hub as an assembly.

PHOTO 1

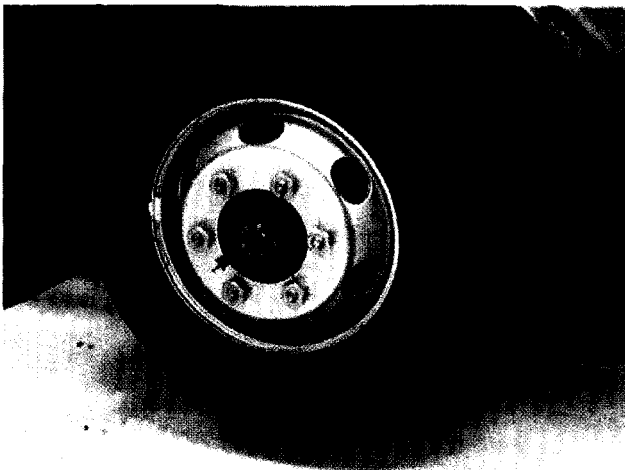
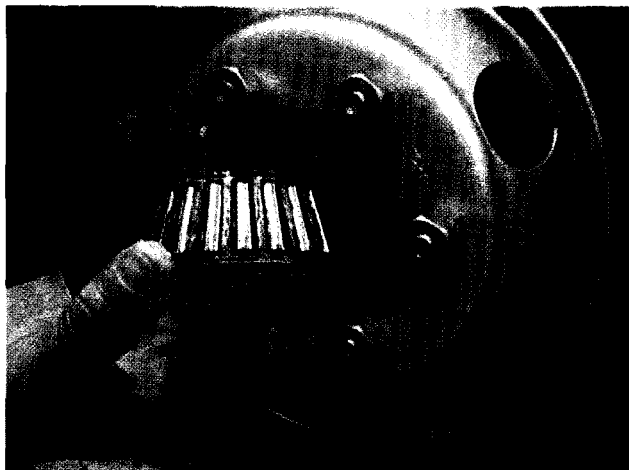

PHOTO 2



3. Clean the old grease from the hub, knuckle and inner/outer bearings and races with solvent and dry.
4. Following the bearing inspection procedures on page four of this Bulletin, carefully examine the inner and outer bearings and races. Replace the bearing/race assembly if any abnormal wear or damage is evident.

**USE THIS SECTION FOR FM657 AND FM65F(FM330) VEHICLES
EQUIPPED WITH AN F070T FRONT AXLE**

MODIFICATION:

The inner and outer front wheel hub bearings must be inspected and properly lubricated. Any bearing showing an abnormality will be replaced. **Please note: The outer hub bearing must be replaced any time an inner bearing is found to have an abnormality.**

PARTS TO BE REPLACED:

Install a new wheel hub oil seal and wheel hub gasket on all vehicles involved. Replace bearings only when signs of damage or abnormality are evident.

Replacement Parts		
Part Number	Description	Quantity
MH034086	Wheel hub oil seal	2
MK309840	Wheel hub gasket	2
MH043140	Outer hub bearing	0-2
MH043082	Inner hub bearing	0-2

RECALL PARTS RETENTION:

All bearings that have been removed and replaced must be properly identified and retained, as outlined in the Warranty and Service Policy Manual, section 3.8. The Field Service Manager will inspect each bearing and authorize its scrapping.

RECALL CLAIM SUBMITTAL:

The two wheel hub oil seals, two hub cover gaskets, grease, solvent, labor and any damaged front hub bearings are reimbursed via the DIN System using the Recall Claim Entry screen. Enter all requested information, including the Recall Number. Choose a Recall Number from the Recall Reimbursement table below that corresponds with the actual parts replaced. The system will apply the labor allowance and parts pricing adjustment shown.

Recall Reimbursement					
Campaign Number	Allowances		Labor Description	Bearings	
C0021111	Labor Time	2.7 hours	Disassembly, cleaning, bearing inspection, seal & hub cap replacement and reassembly, no bearing replacement	None	
	Parts Pricing	\$46.70			
C0021121	Labor Time	3.1 hours	Disassembly, cleaning, bearing inspection, seal & hub cap replacement and replacement of one outer wheel bearing, zero inner wheel bearings	1	MH043140
	Parts Pricing	\$110.22		0	MH043082
C0021131	Labor Time	3.1 hours	Disassembly, cleaning, bearing inspection, seal & hub cap replacement and replacement of two outer wheel bearings, zero inner wheel bearings	2	MH043140
	Parts Pricing	\$173.74		0	MH043082
C0021141	Labor Time	4.5 hours	Disassembly, cleaning, bearing inspection, seal & hub cap replacement and replacement of one outer wheel bearing, one inner wheel bearing	1	MH043140
	Parts Pricing	\$207.93		1	MH043082
C0021151	Labor Time	4.5 hours	Disassembly, cleaning, bearing inspection, seal & hub cap replacement and replacement of two outer wheel bearings, one inner wheel bearing	2	MH043140
	Parts Pricing	\$271.45		1	MH043082
C0021161	Labor Time	4.5 hours	Disassembly, cleaning, bearing inspection, seal & hub cap replacement and replacement of two outer wheel bearings, two inner wheel bearing	2	MH043140
	Parts Pricing	\$369.16		2	MH043082

NOTE: See the Parts Pricing Adjustment table on the bottom of page 8 for reimbursement breakdown.

REPAIR PROCEDURES:

1. Park the vehicle, shut off the engine, apply the parking brake, and chock the rear wheels. Lift the front axle, install jack stands of sufficient capacity and slacken brake adjustment.
2. PERFORM THE FOLLOWING STEPS ON EACH FRONT WHEEL HUB:

Remove and save the wheel hub cover. Properly position a wheel dolly under the wheel assembly. Remove the three lock ring mounting bolts (PHOTO 7) and lock ring. Remove the outer hub nut using the 75mm socket **MH061530**. Remove the lock plate and outer wheel hub bearing (PHOTO 8). Using the wheel dolly, remove the wheel, tire, drum and hub as an assembly.

or, in the absence of a wheel dolly:

Remove and save the wheel hub cover. Remove the wheel and tire assembly. Remove the three lock ring mounting bolts (PHOTO 7) and lock ring. Remove the outer hub nut using the 75mm socket **MH061530**. Remove the lock plate and outer wheel hub bearing (PHOTO 8). Remove the drum and hub as an assembly.

PHOTO 7

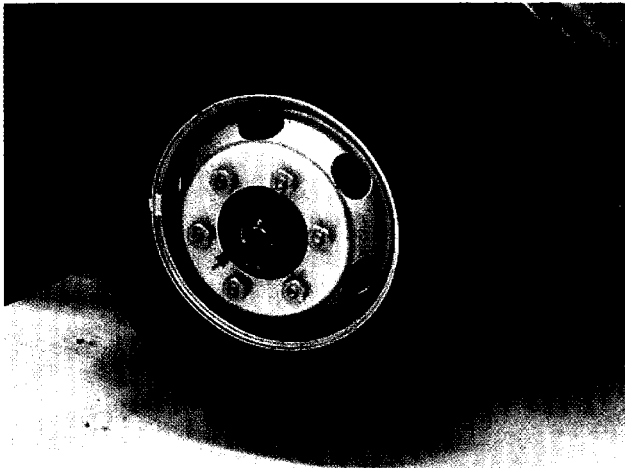
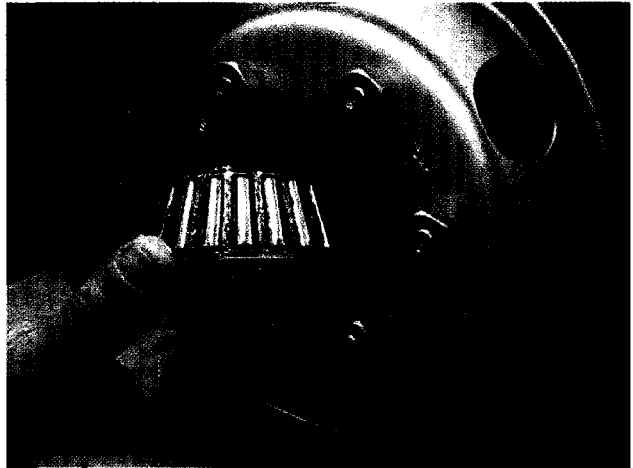

PHOTO 8



3. Clean the old grease from the hub, knuckle and inner/outer bearings and races with solvent and dry.
4. Following the bearing inspection procedures on page eight of this Bulletin, carefully examine the inner and outer bearings and races. Replace the bearing/race assembly if any abnormal wear or damage is evident.
5. Completely repack the inner and outer wheel hub bearings with new wheel bearing grease (NLGI No.2).
6. Fill the inner hub cavity with new NLGI No. 2 wheel bearing grease (approximately **570 grams**).
7. Remove and discard the wheel hub seal and install a new seal **MH034085** (using the hub seal installer **MH062305** and driving handle **MB990938-01**), following proper Service Manual procedures.
8. Apply new NLGI No. 2 grease to the spindle (approximately **90 grams**). Reinstall the wheel, brake drum and hub using the reverse method of removal. **Important! Do not damage the new wheel hub seal during reinstallation.**
9. Reinstall the outer wheel hub bearing, lock plate and outer hub nut. Torque the nut to **148 ft.lbs.**, then slacken the nut **22.5 degrees** (PHOTO 9), following proper Service Manual procedures.
10. Check the starting torque of the wheel hub bearing with a spring scale (PHOTO 10), following proper Service Manual procedures. The tangential force at the wheel bearing should fall within **4.0 to 8.5 lbf.**
11. Reinstall the lock ring and three lock ring mounting bolts. Torque the mounting bolts to **5.1 to 8.0 ft.lbs.**

REPAIR PROCEDURES (cont'd):

- Fill the outer hub cavity with new NGLI No. 2 wheel bearing grease (approximately **150 grams**) to the height of the lock plate edge (ILLUSTRATION 3).
- Clean the wheel hub cover gasket mounting surface. Reinstall the hub cover (with new gasket) and five mounting bolts. Torque the wheel hub cover mounting bolts to **13.7 to 20.3 ft.lbs.**

PHOTO 9

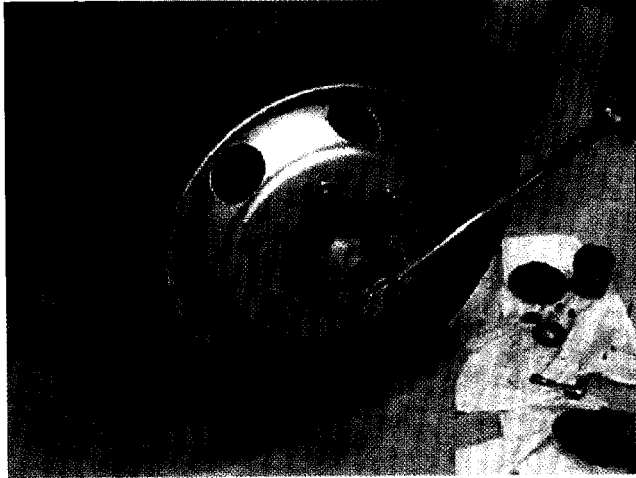

PHOTO 10

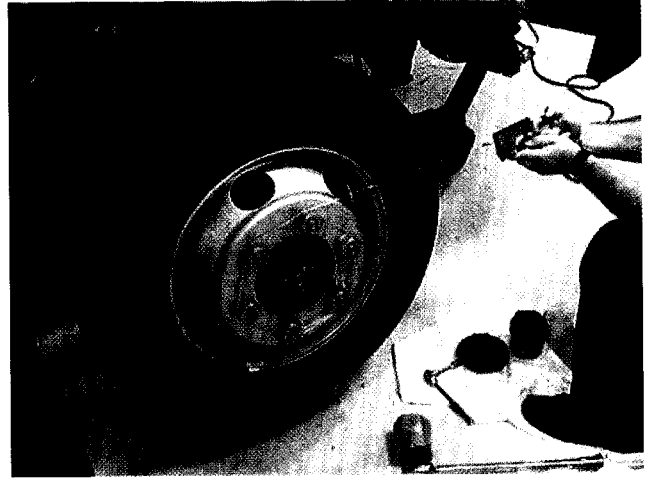
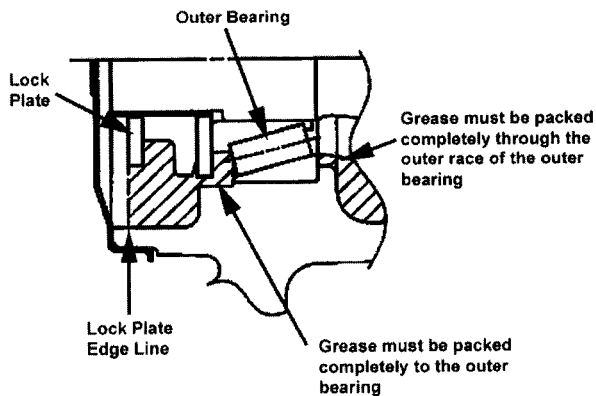
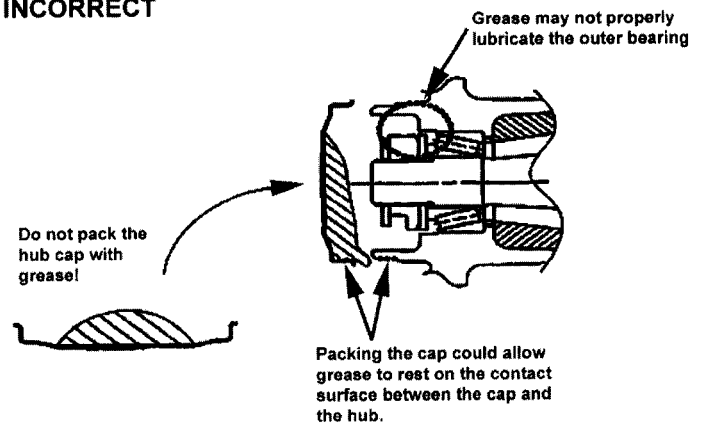

ILLUSTRATION 3

CORRECT



INCORRECT



BEARING INSPECTION PROCEDURES:

1. REUSABLE BEARING:

The following conditions constitute a reusable bearing:

A) The bearing race and roller are discolored due to oiling. The contact point between the bearing race and roller may turn blue or purple in color, due to discoloration by oiling. If the bearing has no abnormality except discoloration due to oiling, reuse it (ILLUSTRATION 4).

B) The contact surface between the bearing race and the roller has fine traces of scarring in the direction of the circumference. This is normal condition and the bearing is reusable (PHOTOS 11 & 12).

ILLUSTRATION 4

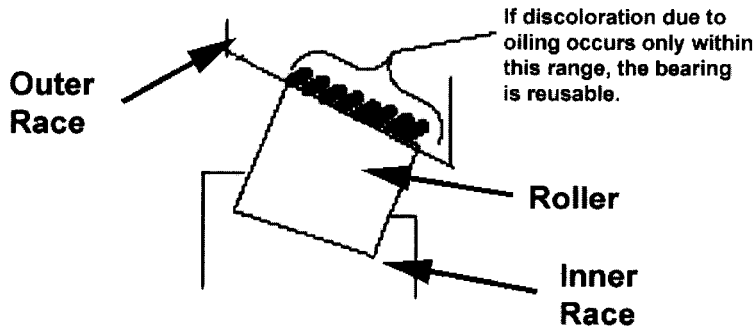
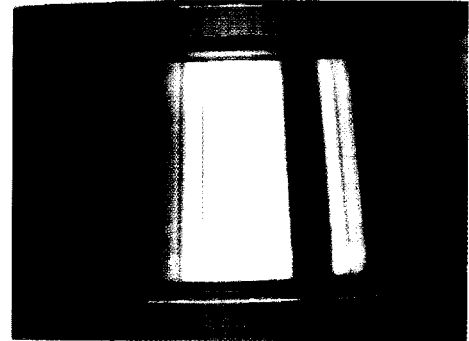
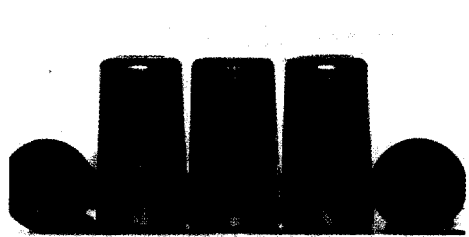

PHOTO 11



Reusable Bearing

PHOTO 12



Reusable Bearing

2. NON-REUSABLE BEARING:

The following conditions constitute a non-reusable bearing, replace with a new bearing:

A) The bearing race, roller and/or cage are corroded/pitted.

B) The contact surface on the bearing races and/or rollers has broken away or is peeling.

C) If the roller surface has indentations, the contact surface of the inner race may have broken away or its surface may have been peeling.

D) If discoloring is found on any portion other than the contact surface of a race and the roller, the bearing may have been overheated. In this case, replace the discolored bearing with a new one.

PARTS PRICING ADJUSTMENT TABLE:

Part #	Part Name	Qty	Dealer Net	30% Mark Up	Recall Reimbursement
MH043140	Outer hub bearing	0-2	48.86	63.52	\$0 - \$127.04
MH043082	Inner hub bearing	0-2	75.16	97.71	\$0 - \$195.42
MH034086	Hub oil seal	2	8.38	10.89	\$21.78
MK309840	Gasket	2	4.97	6.46	\$12.92
	NLGI No. 2 grease				\$8.00
	Solvent				\$4.00

REPAIR PROCEDURES (cont'd):

5. Completely repack the inner and outer wheel hub bearings with new wheel bearing grease (NLGI No.2).
6. Fill the inner hub cavity with new NLGI No. 2 wheel bearing grease (approximately **500 grams**).
7. Remove and discard the wheel hub seal and install a new seal **MH034085** (using the hub seal installer **MH062305** and driving handle **MB990938-01**), following proper Service Manual procedures.
8. Apply new NLGI No. 2 grease to the spindle (approximately **165 grams**). Reinstall the wheel, brake drum and hub using the reverse method of removal. **Important! Do not damage the new wheel hub seal during reinstallation.**
9. Reinstall the outer wheel hub bearing, lock plate and outer hub nut. Torque the nut to **148 ft.lbs.**, then slacken the nut **30 degrees** (PHOTO 3), following proper Service Manual procedures.
10. Check the starting torque of the wheel hub bearing with a spring scale (PHOTO 4), following proper Service Manual procedures. The tangential force at the wheel bearing should fall within **4.0 to 8.5 lbf**.
11. Reinstall the lock ring and three lock ring mounting bolts. Torque the mounting bolts to **5.1 to 8.0 ft.lbs.**
12. Fill the outer hub cavity with new NGLI No. 2 wheel bearing grease (approximately **150 grams**) to the height of the lock plate edge (ILLUSTRATION 1).
13. Clean the wheel hub cover gasket mounting surface. Reinstall the hub cover (with new gasket) and five mounting bolts. Torque the wheel hub cover mounting bolts to **13.7 to 20.3 ft.lbs.**

PHOTO 3

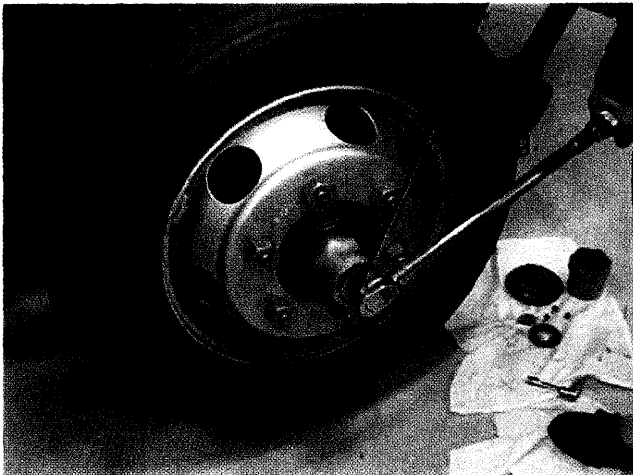

PHOTO 4

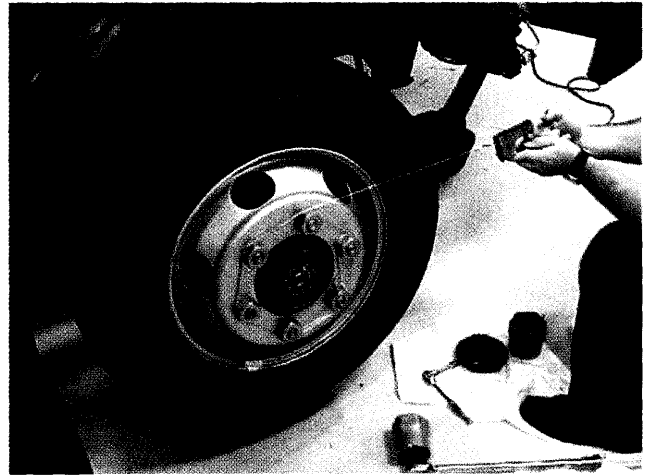
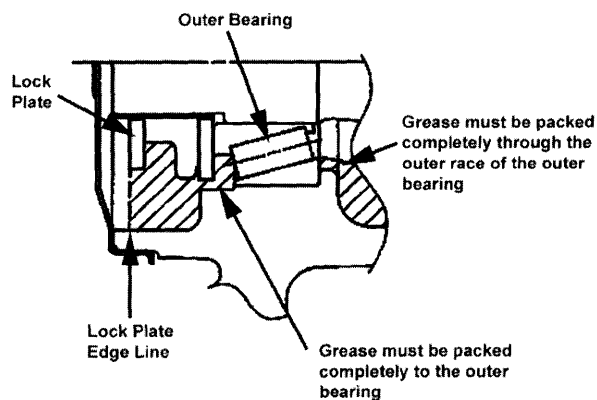
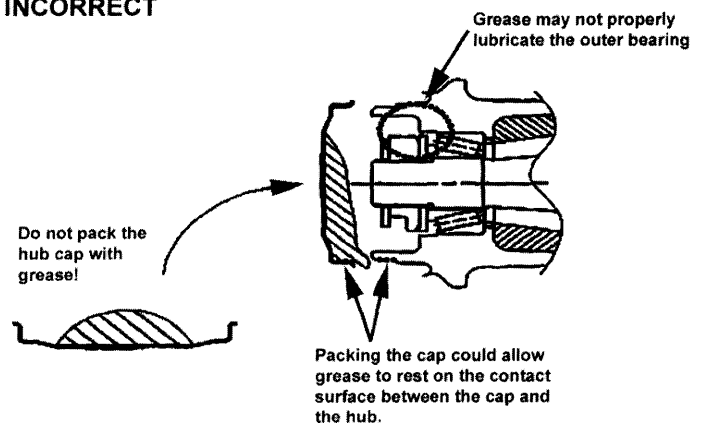

ILLUSTRATION 1

CORRECT



INCORRECT



BEARING INSPECTION PROCEDURES:

1. REUSABLE BEARING:

The following conditions constitute a reusable bearing:

A) The bearing race and roller are discolored due to oiling. The contact point between the bearing race and roller may turn blue or purple in color, due to discoloration by oiling. If the bearing has no abnormality except discoloration due to oiling, reuse it (ILLUSTRATION 2).

B) The contact surface between the bearing race and the roller has fine traces of scarring in the direction of the circumference. This is normal condition and the bearing is reusable (PHOTOS 5 & 6).

ILLUSTRATION 2

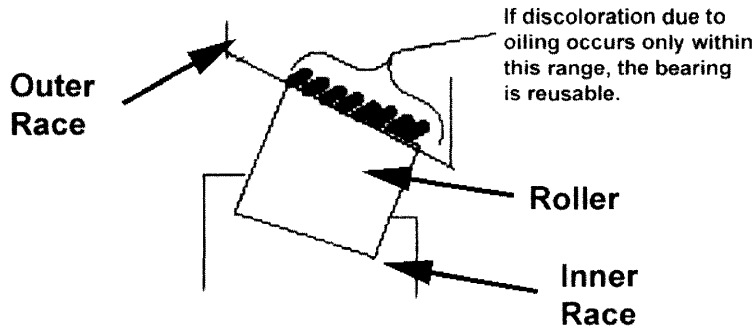
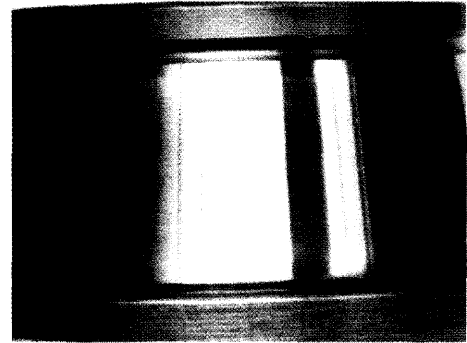
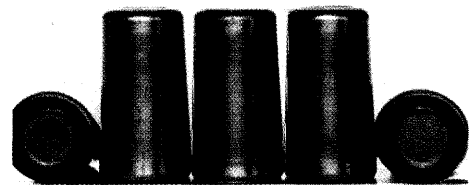

PHOTO 5



Reusable Bearing

PHOTO 6



Reusable Bearing

2. NON-REUSABLE BEARING:

The following conditions constitute a non-reusable bearing, replace with a new bearing:

A) The bearing race, roller and/or cage are corroded/pitted.

B) The contact surface on the bearing races and/or rollers has broken away or is peeling.

C) If the roller surface has indentations, the contact surface of the inner race may have broken away or its surface may have been peeling.

D) If discoloring is found on any portion other than the contact surface of a race and the roller, the bearing may have been overheated. In this case, replace the discolored bearing with a new one.

PARTS PRICING ADJUSTMENT TABLE:

Part #	Part Name	Qty	Dealer Net	30% Mark Up	Recall Reimbursement
MH043127	Outer hub bearing	0-2	33.90	44.07	\$0 - \$88.14
MH043128	Inner hub bearing	0-2	51.31	66.70	\$0 - \$133.40
MH034086	Hub oil seal	2	8.38	10.89	\$21.78
MK309841	Gasket	2	4.02	5.23	\$10.46
	NLGI No. 2 grease				\$8.00
	Solvent				\$4.00



MITSUBISHI FUSO
TRUCK OF AMERICA, Inc.

2015 Center Square Road
Logan Twp., NJ 08085
(856) 467-4500
(856) 467-4695 Fax

Sample

October 25, 2004

CUSTOMER NAME
STREET ADDRESS
CITY, STATE ZIP

**SAFETY RECALL NOTIFICATION: C0021113 – Front Hub Bearing FM
VEHICLES INVOLVED – Certain 2000 – 2005 Model Year FM617, FM657, FM61F, FM64F and FM65F
Trucks**

Vehicle Identification Number – JW6...

This notice is being sent to you in accordance with the requirements of the National Traffic and Motor Vehicle Safety Act. Mitsubishi Fuso Truck of America, Inc. has decided that a defect which relates to motor vehicle safety exists in the front hub bearings on certain vehicles. On affected vehicles, the front wheel hub outer bearing lock nut may have been improperly tightened during initial assembly, and an insufficient amount of grease may have been applied to the outer bearing. These conditions could result in the outer bearing generating excessive heat and/or breaking, causing the vehicle to become disabled. In the worst case, the excessive heat could cause a fire.

The inner and outer wheel bearings will be inspected. If no signs of damage exist, the bearings will be repacked with the factory specified quantity of lubricant and the lock nut will be tightened to the proper specification during reassembly. If signs of damage are found, the affected bearing(s) will be replaced. The procedure will be completed at no cost to you when performed by an Authorized Dealer or Parts and Service Center. The scheduled time for repair is approximately 2.7 – 4.5 hours.

For your continued safety, please contact any Authorized Mitsubishi Fuso Dealer or Parts and Service Center to schedule an appointment for this procedure. Refer to this Recall Notification letter when speaking with Dealer Service Department personnel.

Federal regulation requires that any vehicle lessor receiving this recall notice must forward a copy of this notice to the lessee within ten days. If you are the lessor of the above referenced vehicle, please forward this notification immediately.

Note: If you have incurred costs to obtain a remedy for the problem addressed in this recall, please present the paid invoice to an Authorized Mitsubishi Fuso Dealer or Parts and Service Center. The Dealer/Parts & Service Center will submit a warranty claim to MFTA on your behalf. Reimbursement of these costs should be expected within approximately 30 days of warranty claim submittal.

We at MFTA regret any inconvenience this situation may cause you. However, your safety and continued satisfaction with our product are most important to us.

If your MFTA Dealer is unable to perform this procedure without charge, or within a reasonable amount of time, please contact MFTA Customer Service toll-free at 877-711-0707 for assistance. You may also contact the Administrator, National Highway Traffic Safety Administration, 400 Seventh St. SW, Washington, DC 20590; or call the toll-free Auto Safety Hotline at 888-327-4236.

Sincerely,

A handwritten signature in black ink that reads "William P. Mohr".

William P. Mohr
Director, Service Operations