

Ford Motor Company

James P. Vondale, Director
Automotive Safety Office
Environmental & Safety Engineering

October 12, 2004

Mr. George Person, Chief
Recall Management Division (NVS-215)
Office of Defects Investigation
National Highway Traffic Safety Administration
400 Seventh Street, S.W.
Washington, DC 20590

Dear Mr. Person:

Subject: Safety Recall 04V-442
(Ford Number 04S20)

Pursuant to the requirements set forth in Part 573 of Title 49 of the Code of Federal Regulations -- Defect and Noncompliance Reports, Ford Motor Company is submitting a true or representative copy of information that relates directly to the subject campaign.

Attached are dealer and owner letters issued by Ford Customer Service Division regarding a recall of all 2002 and 2003 model year Explorer and Mountaineer vehicles. Specific details were submitted to you in a letter dated September 9, 2004. Owner notification letters were mailed on September 30, 2004.

Sincerely,

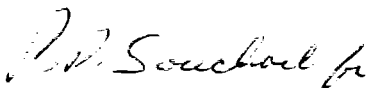

J. P. Vondale

Attachment(s)
04S20 Dealer-Owner Bulletin





Frank M. Ligon
Director
Service Engineering Operations
Ford Customer Service Division

Ford Motor Company
P. O. Box 1904
Dearborn, Michigan 48121

September 9, 2004

TO: All U.S. Ford and Lincoln Mercury Dealers

SUBJECT: Advance Notice - Safety Recall 04S20:
All 2002 and Certain 2003 Model Year Ford Explorer & Mercury Mountaineer Vehicles
Liftgate Glass Hinge and Ball Stud Bracket (if applicable) Replacement

AFFECTED VEHICLES

All 2002 and 2003 model year Ford Explorer and Mercury Mountaineer vehicles built at St Louis Assembly Plant (SLAP) and Louisville Assembly Plant (LAP) from Job #1 2002 through June 23, 2003.

Affected vehicles are identified in OASIS. In addition, for a list of unsold vehicles assigned to your dealership, visit <https://web.fsavinlists.dealerconnection.com>. This information will be available on 9/13/2004.

REASON FOR THIS SAFETY RECALL

In some of the affected 2002 model year vehicles, the ball stud bracket located on the rear liftgate window could rotate out of position on the glass. If this occurs, the window lift strut may detach and become trapped between the glass and the liftgate, possibly causing the window to drop unexpectedly or break.

In all of the affected vehicles (2002 and 2003 MY), the hinge which attaches the liftgate window to the liftgate body may separate from the liftgate body. If this occurs, the window could drop unexpectedly or break. If the liftgate window drops or breaks, either the person operating the window or a nearby person could be injured.

SERVICE ACTION

A complete Dealer Bulletin will be provided to Dealers the week of September 20, 2004 when it is anticipated that parts ordering information and repair instructions will be available to support this safety recall.

CUSTOMER NOTIFICATION

Owners of record will be notified via first-class mail after repair instructions and parts ordering information have been provided to dealers.

OASIS

Consult OASIS for affected vehicles. FSA VIN listings for unsold vehicles will be available September 13, 2004.

PLEASE NOTE:

Correct all vehicles in stock before delivery. Federal law requires dealers to complete any outstanding safety recall service before a new vehicle is delivered to the buyer or lessee. Violation of this requirement by a dealer could result in a civil penalty of up to \$5,000 per vehicle.

QUESTIONS?

Special Service Support Center (Dealer Only) Questions: 1-800-325-5621

Sincerely,

A handwritten signature in black ink that reads "Frank M. Ligon". The signature is written in a cursive style with a large, stylized 'F' and 'L'.

Frank M. Ligon



Frank M. Ligon
Director
Service Engineering Operations
Ford Customer Service Division

Ford Motor Company
P. O. Box 1904
Dearborn, Michigan 48121

September 2004

TO: All U.S. Ford and Lincoln Mercury Dealers

SUBJECT: Safety Recall 04S20

All 2002 and Certain 2003 Model Year Ford Explorer & Mercury Mountaineer Vehicles
Liftgate Glass Hinge and Ball Stud Bracket (if applicable) Replacement

Ref: Advance Notice - Safety Recall 04S20 dated 9/9/04

All 2002 and Certain 2003 Model Year Ford Explorer & Mercury Mountaineer Vehicles
Liftgate Glass Hinge and Ball Stud Bracket (if applicable) Replacement

AFFECTED VEHICLES

All 2002 and 2003 model year Ford Explorer and Mercury Mountaineer vehicles built at St. Louis Assembly Plant (SLAP) and at Louisville Assembly Plant (LAP) from Job #1 2002 through June 23, 2003. Affected vehicles are identified in OASIS. In addition, for a list of vehicles assigned to your dealership, visit <https://web.fsavinlists.dealerconnection.com>.

REASON FOR THIS SAFETY RECALL

In some of the affected 2002 model year vehicles, the ball stud bracket located on the rear liftgate window could rotate out of position on the glass. If this occurs, the window strut may detach and become trapped between the glass and the liftgate, possibly causing the window to drop unexpectedly or break.

On all of the affected vehicles (2002 and 2003 MY), the hinge which attaches the liftgate window to the liftgate body may separate from the liftgate body. If this occurs, the window could drop unexpectedly or break.

If the liftgate window drops or breaks, either the person operating the window or a nearby person could be injured.

SERVICE ACTION

Service parts to repair this condition are currently not available. Owners of affected vehicles will be advised the week of 10/4/04 not to use the liftgate glass until this Safety Recall has been performed. It is expected that Ball Stud Bracket and Hinge service kits will be available in late November 2004.

If you encounter an affected vehicle with a broken hinge, a rotated ball stud bracket, or a broken rear window before parts are available, call the Special Service Support Center at 1-800-325-5621 for further instructions.

Please Note: Although this repair involves the liftgate glass, this is not a glass repair. This is a hardware installation. Therefore, we recommend that this repair be completed in your service department and not be sublet to glass shops.

Vehicles Built From Job #1, 2002 Through March 3, 2002 (LAP) or March 10, 2002 (SLAP)
(See Attachment III for a visual method for identifying these vehicles utilizing the liftgate glass beauty bolts.)

At no charge to the vehicle owner, dealers are to replace both the right and left hand liftgate glass ball stud mounting brackets with a new design bracket. In addition, dealers are to replace both the right and left hand liftgate window hinges. This must be performed on all of the affected vehicles in your inventory as well as vehicles that have been delivered to customers.

PLEASE NOTE: The adhesive used to install the liftgate glass ball stud brackets will require at least two (2) hours to cure at 70° F or higher. If the vehicle must be moved to a much colder environment before two hours has elapsed, cure time may increase substantially before the liftgate glass struts can be reattached.

PLEASE NOTE: We strongly advise dealers to schedule morning appointments for vehicles that require bracket replacement. By replacing the ball stud brackets in the morning, dealers will have the flexibility to allow the adhesive to properly cure and still allow the customer to pick up their vehicle before the end of the day. See "Rental Vehicles" in Attachment I for unusual circumstances where the two-hour cure time cannot be accommodated.

Vehicles Built From March 4, 2002 (LAP) or March 11, 2002 (SLAP) through June 23, 2003
(See Attachment III for a visual method for identifying these vehicles utilizing the liftgate glass beauty bolts.)

At no charge to the vehicle owner, dealers are to replace both the right and left hand liftgate window hinges only. This must be performed on all of the affected vehicles in your inventory as well as vehicles that have been delivered to customers. Vehicles built in this period do not require replacement of the ball stud strut brackets.

PLEASE NOTE:

Correct all vehicles in stock before delivery. Federal law requires dealers to complete any outstanding safety recall service before a new vehicle is delivered to the buyer or lessee. Violation of this requirement by a dealer could result in a civil penalty of up to \$5,000 per vehicle.

ATTACHMENTS

Attachment I: Administrative Information
Attachment II: Labor Allowances and Parts Ordering Information
Attachment III: Technical Information
Attachment IV: Dealer Questions and Answers
Customer Notification Letters

QUESTIONS?

Claims Information: 1-800-423-8851
Special Service Support Center (Dealer Only) Questions: 1-800-325-5621

Sincerely,

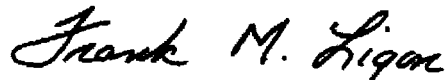

Frank M. Ligon

Safety Recall 04S20

All 2002 and Certain 2003 Model Year Ford Explorer & Mercury Mountaineer Vehicles
Liftgate Glass Hinge and Ball Stud Bracket (if applicable) Replacement

OASIS ACTIVATED? Yes. OASIS was activated 9/9/2004.

FSA VIN LIST ACTIVATED? Yes.

Available through FMCDDealer.com or at <https://web.fsavinlists.dealerconnection.com>

Owner names and addresses will be available by 10/15/04.

NOTE: Your FSA VIN list may contain owner names and addresses obtained from motor vehicle registration records. The use of such motor vehicle registration data for any purpose other than in connection with this recall is a violation of law in several states, provinces, and countries. Accordingly, you must limit the use of this listing to the follow-up necessary to complete this recall action.

STOCK VEHICLES

Correct all affected stock vehicles before delivery.

SOLD VEHICLES

- When parts are available, owners of affected vehicles will be directed to dealers for repairs.
- Contact any of your affected owners whose vehicles are not on your VIN lists but are identified in OASIS. Give the owner a copy of the Customer Notification Letter (when available).
- When parts are available, correct other affected vehicles identified in OASIS which are brought to your dealership.

TITLE BRANDED / SALVAGED VEHICLES

Affected title branded and salvaged vehicles are eligible for this Field Service Action.

RELATED DAMAGE

- If a related damage condition exists that you believe to be caused by the covered condition, call the Special Service Support Center to request approval **prior** to the repair of any related damage. Requests for approval after completion of the repair will not be granted.
- Refer to Attachment IV for additional information.

ADDITIONAL LABOR TIME

- If a condition exists that requires additional labor to complete the repair, call the Special Service Support Center to request approval **prior** to performing any additional labor. Requests for approval after completion of the repair will not be granted.
- If you encounter aftermarket equipment or modifications to the vehicle that might prevent the repair of the covered condition, call the Special Service Support Center.

Safety Recall 04S20

All 2002 and Certain 2003 Model Year Ford Explorer & Mercury Mountaineer Vehicles
Liftgate Glass Hinge and Ball Stud Bracket (if applicable) Replacement

OWNER REFUNDS

- Ford Motor Company is offering a refund for owner-paid repairs covered by this recall if the repair was performed prior to the date indicated in the reimbursement plan, which is posted with this bulletin. This plan is also available to owners through the Customer Relationship Center (CRC). The CRC will direct owners to seek reimbursement through authorized dealers or, at an owners' option, directly through Ford Motor Company at P.O. Box 6251, Dearborn, MI 48121-6251.
- Dealers are also authorized to refund owner-paid emergency repairs that were performed away from an authorized servicing dealer after the end date specified in the reimbursement plan. Refund claims that include other non-covered repairs, or those judged by Ford to be excessive, will not be accepted for reimbursement.
- **This safety recall must still be performed, even if the customer has paid for a previous repair. Claiming a refund will not close out the VIN for this recall.**
- Refund Claiming Information (Submit on separate repair line.)
 - Program Code: 04S20
 - Misc. Expense: REFUND
 - Misc. Expense: ADMIN
 - Misc. Expense: 0.2 Hrs.

RENTAL VEHICLES

A rental vehicle is only authorized when:

- A vehicle arrives with a shattered back glass and a new glass must be ordered.
- Service department volume or scheduling makes it impossible to store vehicles which require bracket replacement at 70° F or higher for two hours. It is anticipated that rental vehicles will only be required in limited circumstances.

NOTE: Rental vehicles are not covered under this program for vehicles which only require hinge replacement.

CLAIMS PREPARATION AND SUBMISSION

- Enter claims using Direct Warranty Entry (DWE).
- Refund or related damage must be claimed on a repair line that is separate from the repair line on which the FSA is claimed.
- "MT" labor should be submitted on a separate repair line with the related damage flag checked.
- Refer to ACESII manual for claims preparation and submission information.

Safety Recall 04S20

All 2002 and Certain 2003 Model Year Ford Explorer & Mercury Mountaineer Vehicles
Liftgate Glass Hinge and Ball Stud Bracket (if applicable) Replacement

LABOR ALLOWANCES

Description	Labor Operation	Labor Time
Vehicles with Beauty Bolts Replace both liftgate glass ball stud brackets and both liftgate glass hinges - vehicles built from Job #1 2002 through March 10, 2002 (SLAP) or through March 3, 2002 (LAP) units.	04S20B	0.8 Hour
Vehicles without Beauty Bolts Replace both liftgate glass hinges - vehicles built from March 11, 2002 (SLAP) or March 4, 2002 (LAP) through June 23, 2003.	04S20C	0.4 Hour

TOOL REQUIREMENTS

Rotunda Tool 501-040 is required to complete the ball stud bracket replacement. Each dealer will be provided one applicator tool 501-040, when parts become available.

PARTS REQUIREMENTS / ORDERING INFORMATION

Parts to repair this condition are currently not available. Owners of affected vehicles will be advised not to use the liftgate glass until parts are available and this Safety Recall has been performed. It is expected that Ball Stud Bracket and Hinge service kits will be available in late November 2004. *

Part Number	Description	Quantity
TBD*	New parts are being developed – Dealers will be advised when parts are available.*	

***NOTE:** If you encounter an affected vehicle with a broken hinge, a rotated ball stud bracket, or a broken rear window before parts are available, call the Special Service Support Center at 1-800-325-5621 for further instructions.

DEALER PRICE

For latest prices, refer to DOES II.

PARTS RETENTION AND RETURN

Follow the provisions of the Warranty and Policy Manual for "Parts Retention and Return Procedures."

EXCESS STOCK RETURN

Excess stock returned for credit must have been purchased from Ford Customer Service Division in accordance with Policy Procedure Bulletin 4000.

CERTAIN 2002 AND 2003 MODEL YEAR EXPLORER/MOUNTAINEER VEHICLES — LIFTGATE GLASS BALL STUD BRACKET AND HINGE REPLACEMENT

OVERVIEW

This program involves replacing the liftgate glass ball stud brackets and liftgate glass hinges on certain 2002 and 2003 Model Year Explorer and Mountaineer vehicles.

- On early built 2002 model year vehicles, the liftgate glass ball stud brackets and liftgate glass hinges require replacement.
- On later built 2002 and all early 2003 model year vehicles only the liftgate glass hinges require replacement.

INSPECTION

To properly identify the vehicle and decide which repairs to perform, inspect for the presence of liftgate glass beauty bolts.

- Early 2002 models use ball stud brackets which are secured with beauty bolts which pass through the glass (the head of the bolt is visible on the outside of the glass) and are bonded to the glass about 150 mm (6 inches) from the top of the glass. See Figure 1. If beauty bolts are present, both the liftgate ball stud brackets and hinges will be replaced. Perform **BOTH** the Liftgate Glass Hinge Replacement and the Ball Stud Bracket Replacement. Begin your repairs with **LIFTGATE GLASS HINGE REPLACEMENT**.
- Later built 2002 and 2003 model year vehicles use revised ball stud brackets which are not secured with beauty bolts. If beauty bolts are not present, only the hinges will be replaced. Perform only the **LIFTGATE GLASS HINGE REPLACEMENT**.

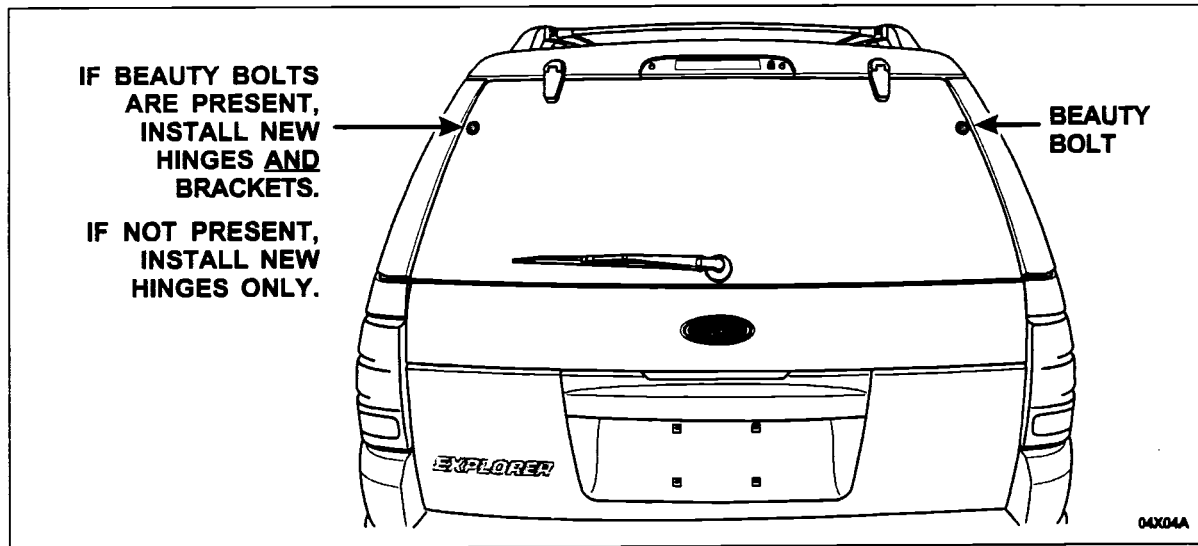

FIGURE 1



LIFTGATE GLASS HINGE REPLACEMENT – ALL AFFECTED VEHICLES

NOTE: The Hinge Replacement procedure must be completed prior to the Ball Stud Bracket procedure.

REMOVAL

WARNING: PERSONAL PROTECTIVE EQUIPMENT (SAFETY GLASSES) IS REQUIRED WHEN WORKING WITH GLASS OR INJURY MAY OCCUR IN THE EVENT OF GLASS BREAKAGE.

CAUTION: Do not use power tools when working on the glass.

1. Open the liftgate glass and support the glass with a jack stand positioned under the striker.
2. Disconnect the liftgate glass support struts from both ends and remove from the vehicle.
3. Remove the jack stand and carefully close the glass making sure the striker is engaged in the latch.
4. Open the full liftgate.
5. Position the upper part of the liftgate trim panel away from the liftgate to gain access to the hinge fasteners. See Figure 2.

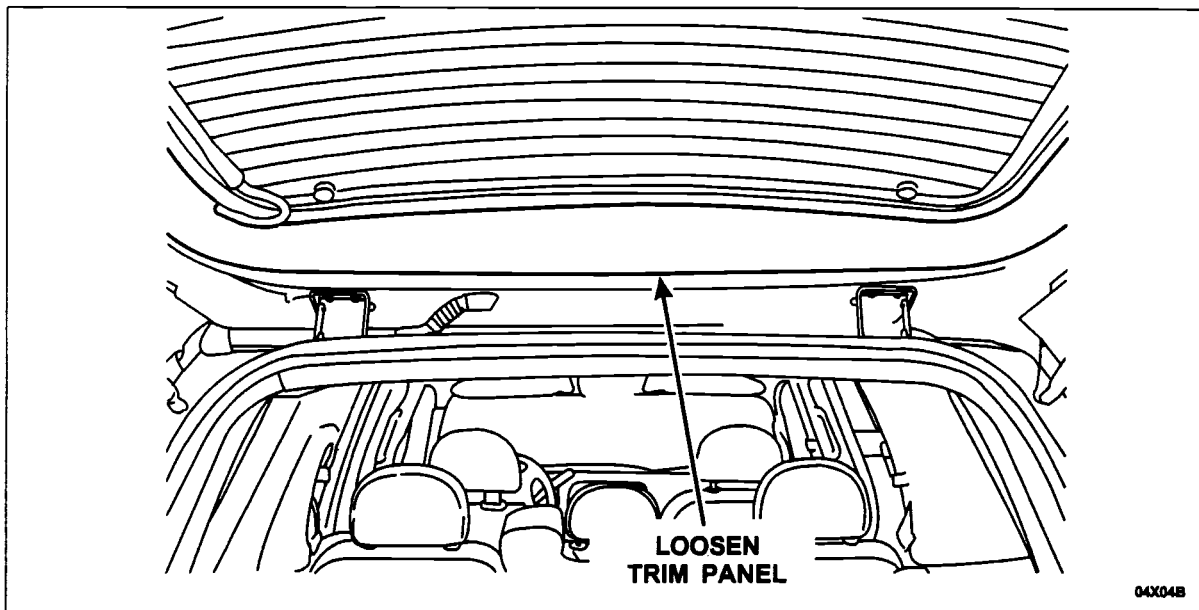

FIGURE 2



NOTE: Replace only one hinge at a time for ease of installation and to assist in keeping the glass properly aligned.

- Using a magnetic socket or tool, remove one (1) liftgate glass hinge-to-body nut then the hinge-to-glass bolt and remove one (1) hinge from the vehicle. See Figure 3.

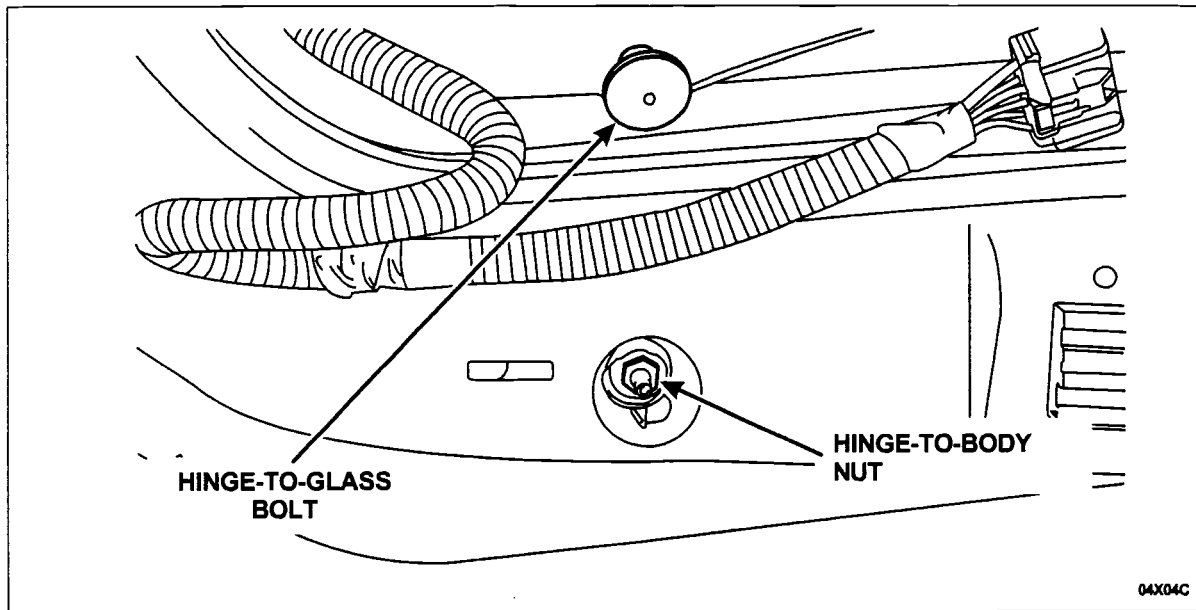

FIGURE 3

INSTALLATION

- Apply Threadlock 262 (Motorcraft TA-26, red high strength) to the hinge-to-glass bolt, then position the hinge onto the vehicle.
- Install the hinge bolt and nut **FINGER TIGHT ONLY** at this time.
- Tighten the hinge **BOLT FIRST** to 8 Nm (71 lb-in).
- Tighten the hinge **NUT SECOND** to 11 Nm (8 lb-ft or 97 lb-in).
- Repeat Removal Step 6 and Installation Steps 1 through 4 for the other hinge.
- Reposition and secure the liftgate trim panel.
- Close the liftgate.

NOTE: If the beauty bolts are present (See INSPECTION, page 1), proceed to the Liftgate Ball Stud Bracket Replacement procedure. If the beauty bolts are **NOT** present, complete Steps 8 and 9 and release the vehicle.

- Install the liftgate glass support struts.
- Remove the jack stand and close the liftgate glass.



LIFTGATE GLASS BALL STUD BRACKET REPLACEMENT – EARLY 2002 MODEL YEAR VEHICLES ONLY (VEHICLES WITH BEAUTY BOLTS)

CAUTION: Do not use power tools when working on glass.

NOTE: The *new* brackets are marked with a stamping, L or R followed by a number. They are NOT interchangeable. The L is for the driver side of the glass and has left-hand threads. The R is for the passenger side of the glass and has right-hand threads. The number can be ignored. See Figure 4.

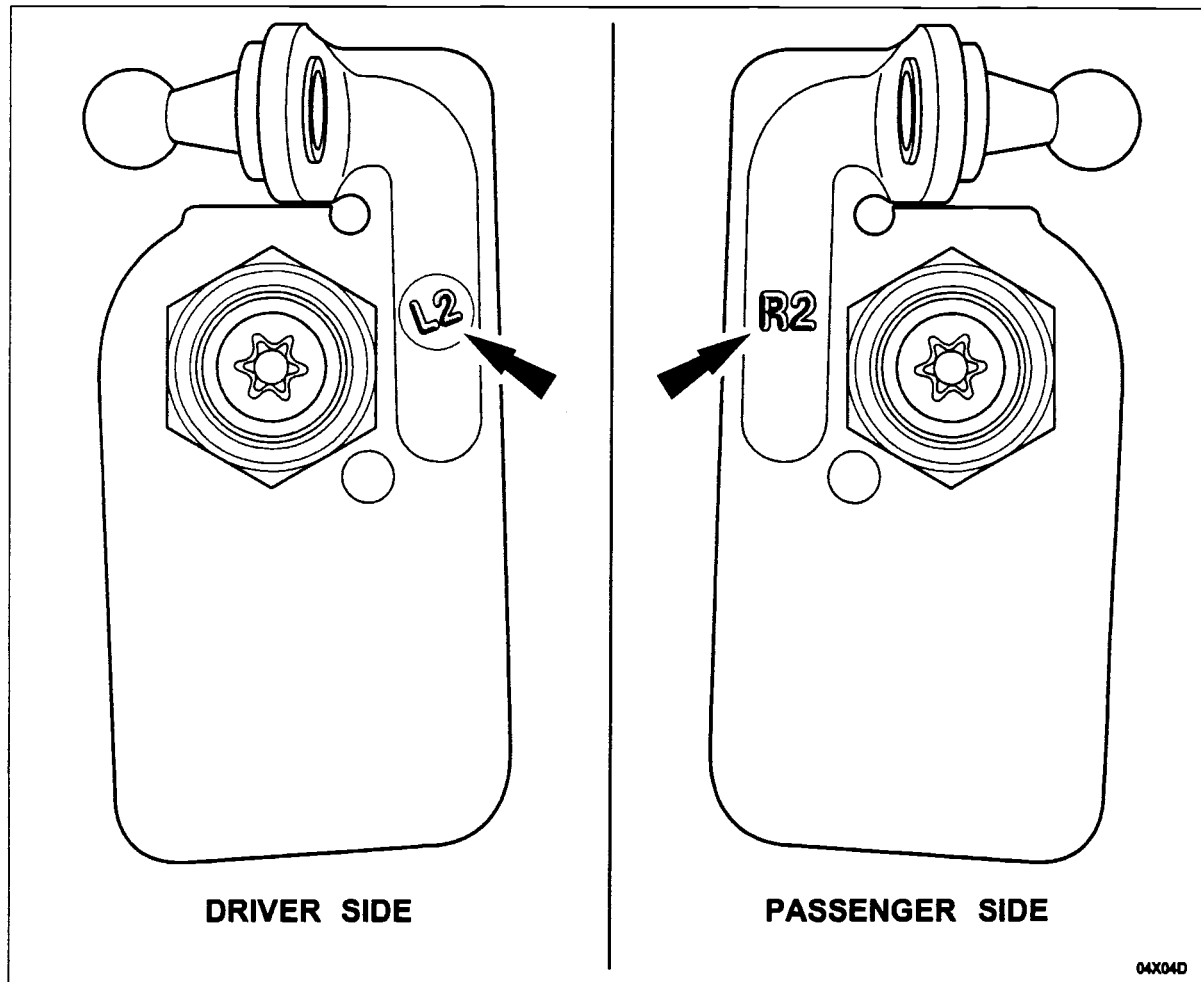

FIGURE 4



CAUTION: Due to the extremely short working time of the adhesive (less than one [1] minute), it is imperative that only one (1) bracket be replaced at a time. Failure to specifically follow these instructions will result in a ruined backglass or failure of the adhesive to bond properly to the glass.

NOTE: Before the installation of the liftgate glass ball stud bracket, make sure that the interior surface of the glass is clean and free of any visible moisture.

1. Open the liftgate glass and support the glass with a jack stand positioned under the striker.
2. **WARNING: PERSONAL PROTECTIVE EQUIPMENT (SAFETY GLASSES) IS REQUIRED WHEN WORKING WITH GLASS OR INJURY MAY OCCUR IN THE EVENT OF GLASS BREAKAGE.**

Remove the bracket from the glass by first removing the beauty bolt using a T-30 Torx bit, then twisting the bracket off the glass using a 17-mm box-end wrench.

NOTE: With the liftgate glass open, be sure to properly orient the *new* brackets with the ball stud pointing upward and outward. See Figure 5.

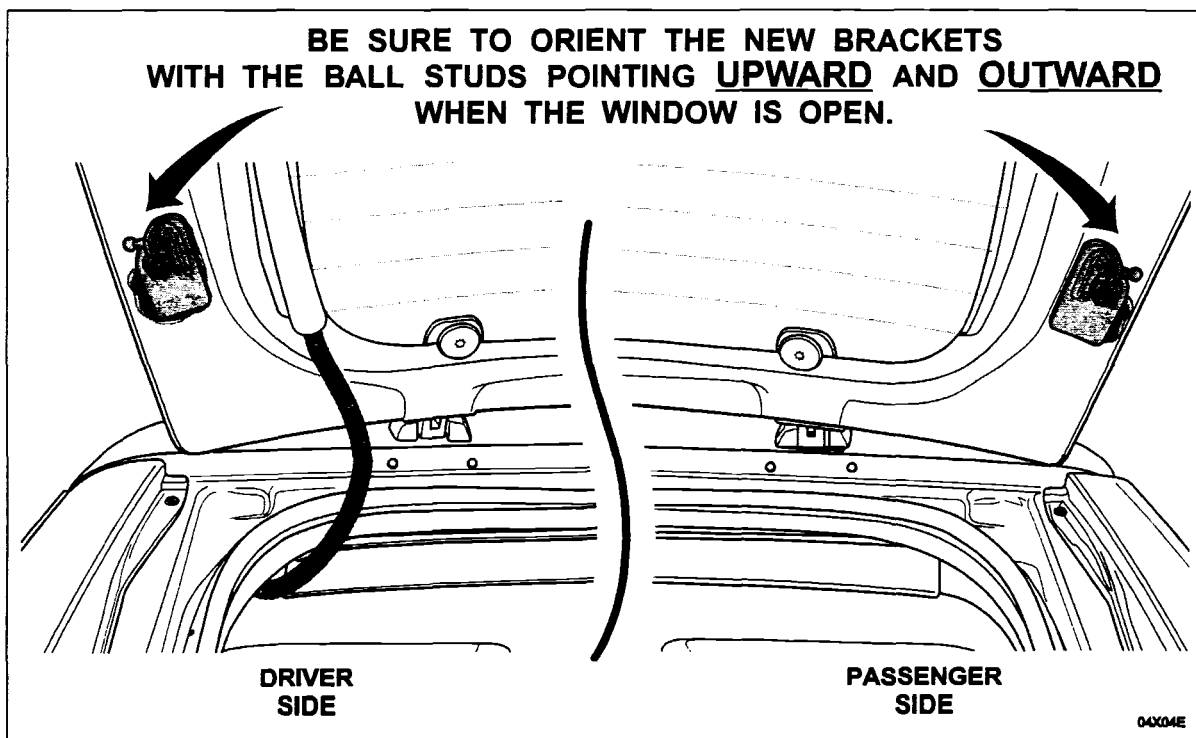

FIGURE 5



3. Hold the **new** bracket in position on the glass with the ball stud pointing UP and OUT (with the liftgate glass open). Mark the area around the bracket using masking tape or vinyl tape. Leave a space approximately 7 mm ($\frac{1}{4}$ in) between the edge of the bracket and the tape. The taped-off area should be approximately 57-mm ($2\frac{1}{4}$ in) wide and 89-mm ($3\frac{1}{2}$ in) high. See Figure 6 for proper placement and dimensions. After the tape is applied, remove the bracket. The tape will be used as an alignment guide, therefore, keep the tape in place until completing the final bracket alignment.

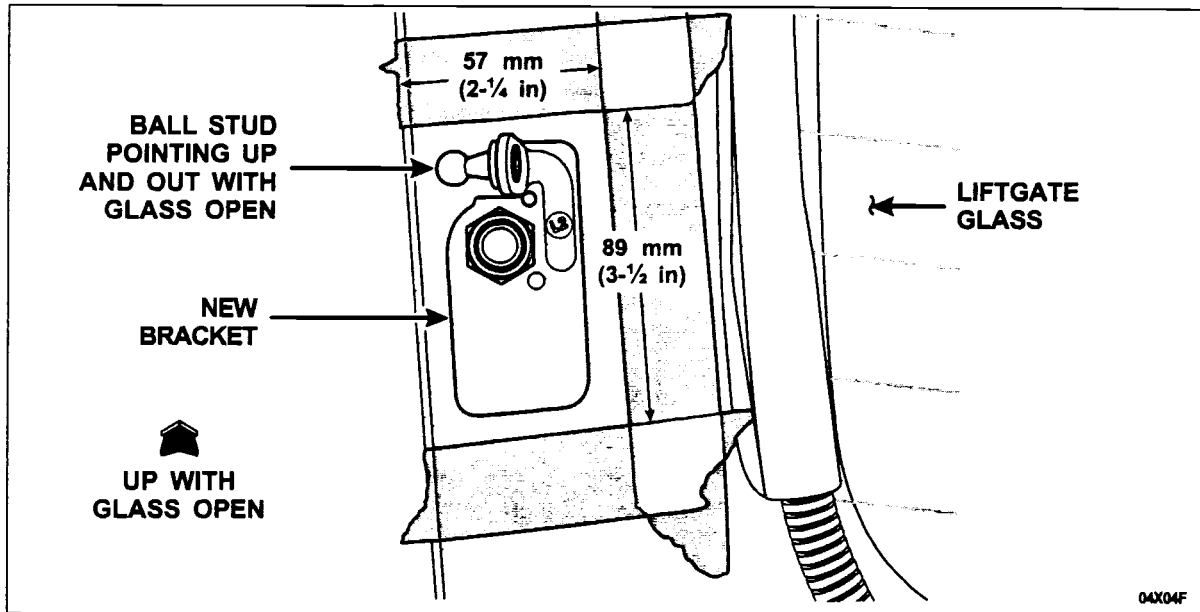

FIGURE 6



8. Install the plastic spacer (with locating tab) and rubber washer onto the *new* brackets as shown in Figure 8. Also, place a plastic washer onto the beauty bolt with the collar toward the glass.

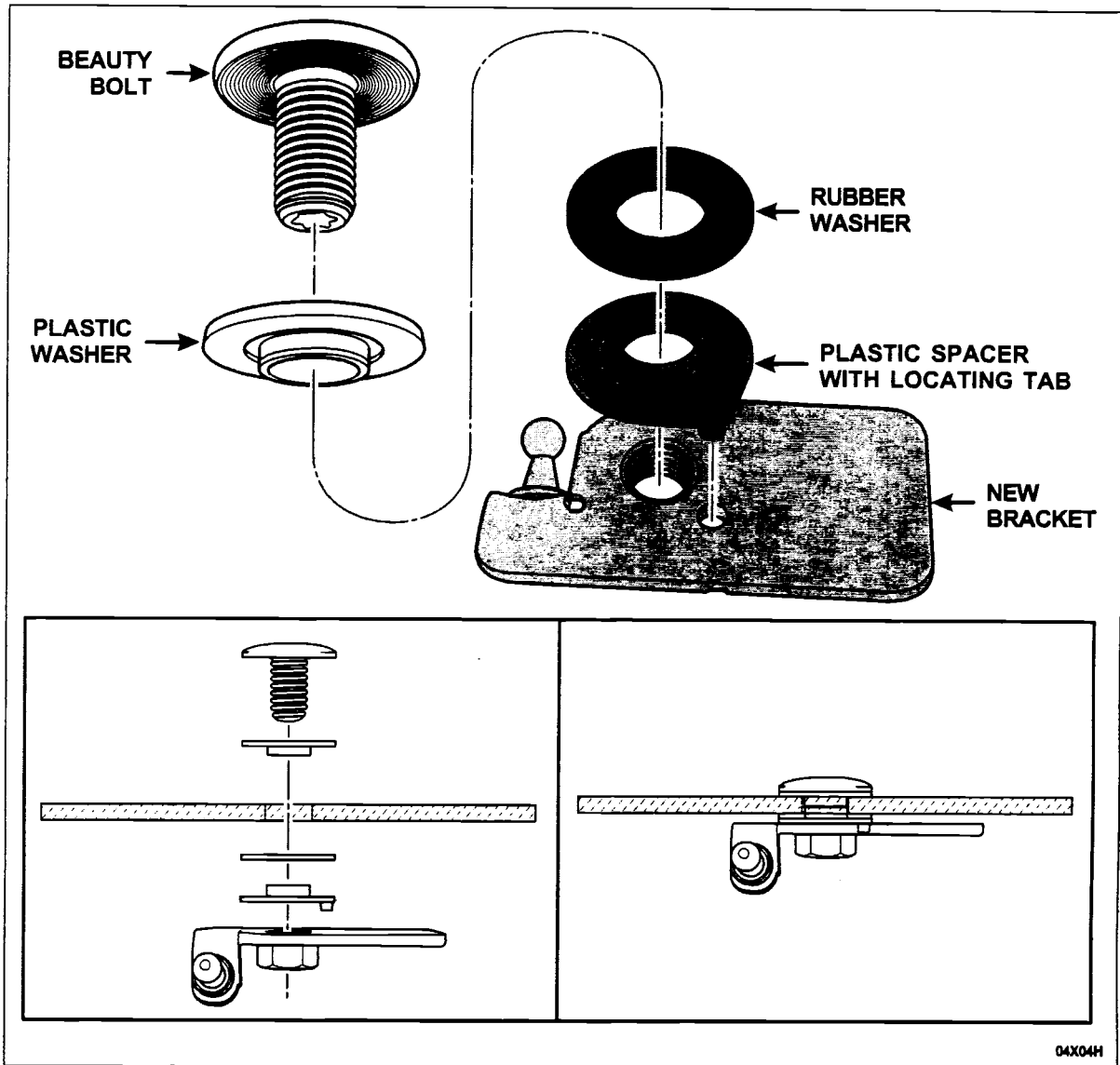

FIGURE 8



9. **CAUTION:** Failure to prepare the adhesive cartridge and mixer tip as described may cause insufficient mixing of the product. This may lead to insufficient bonding of the bracket(s) to the glass.

Assemble the adhesive cartridge and application tool and purge the cartridge as follows:

- A) Trim approximately 13 mm (0.5 in) off the top of both mixer tips, down to the last ring. See Figure 9.
- B) Install the Fusor® #143 adhesive cartridge into the application tool (No. 501-040).
- C) Dispense a small amount of adhesive from the cartridge onto a piece of scrap cardboard to level the plungers and to ensure an even flow of both components.
- D) Install one (1) mixer tip onto the cartridge and dispense a 75-mm (3-in) bead of the adhesive onto a piece of scrap cardboard (until the product is evenly mixed and the color is consistent).

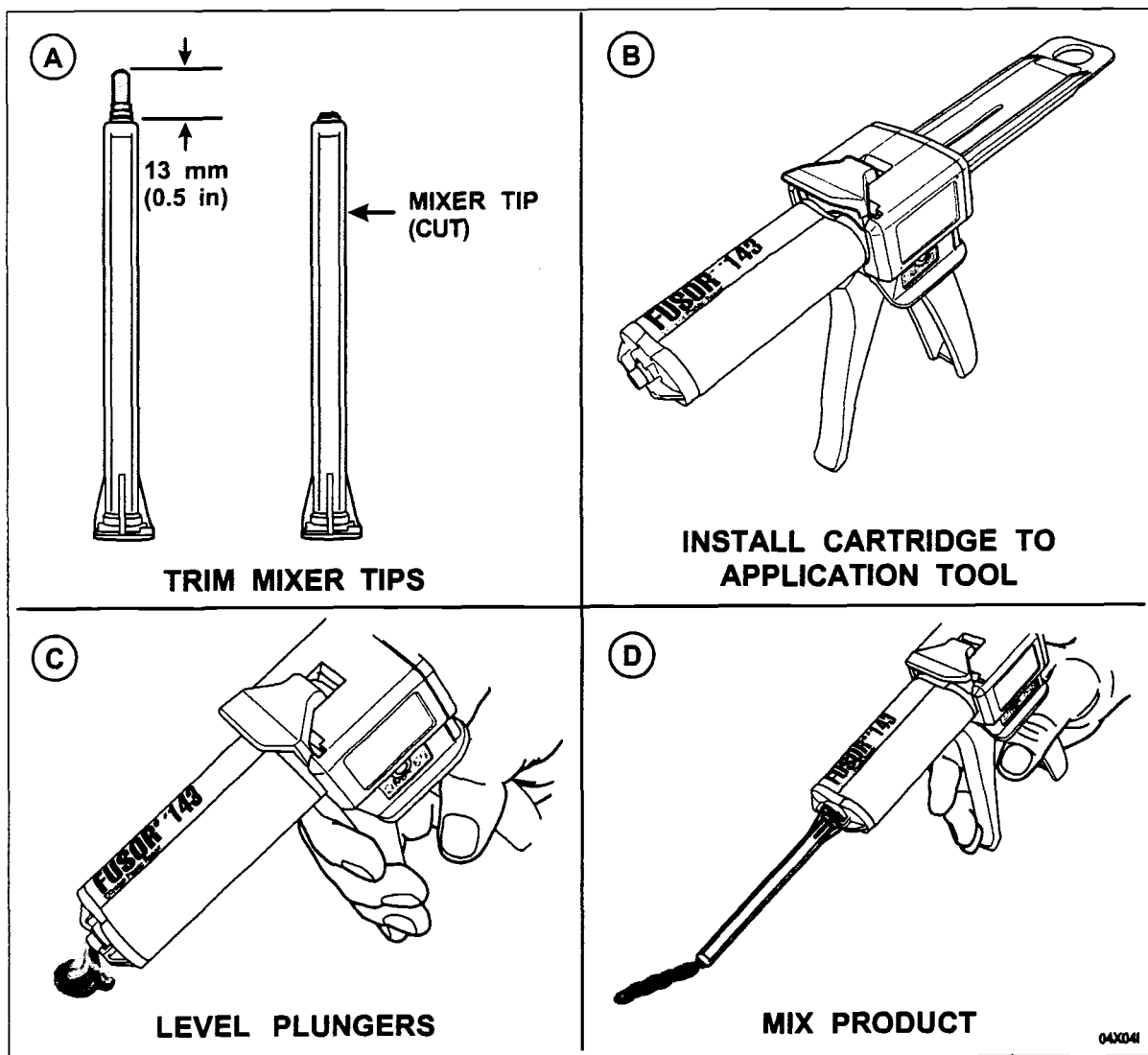

FIGURE 9



NOTE: Due to the working times involved and the necessity of changing mixing tips on the application tool, these instructions are written to perform installation of the left-side bracket first, then the right-side bracket. Please review these instructions and understand the process before proceeding with adhesive application and bracket installation.

10. NOTE: Once the adhesive mixes, you will have less than one (1) minute to install the *new* bracket before the adhesive begins to set. The adhesive will require at least two (2) hours at 70°F or higher to cure before the liftgate glass support struts can be attached.

NOTE: Keep the used mixer tip attached to the cartridge after use.

After the primer has dried for fifteen (15) minutes, apply three (3) **large** beads (9-10 mm in diameter) of adhesive to the backside of the *new* left-side bracket. See Figure 10.

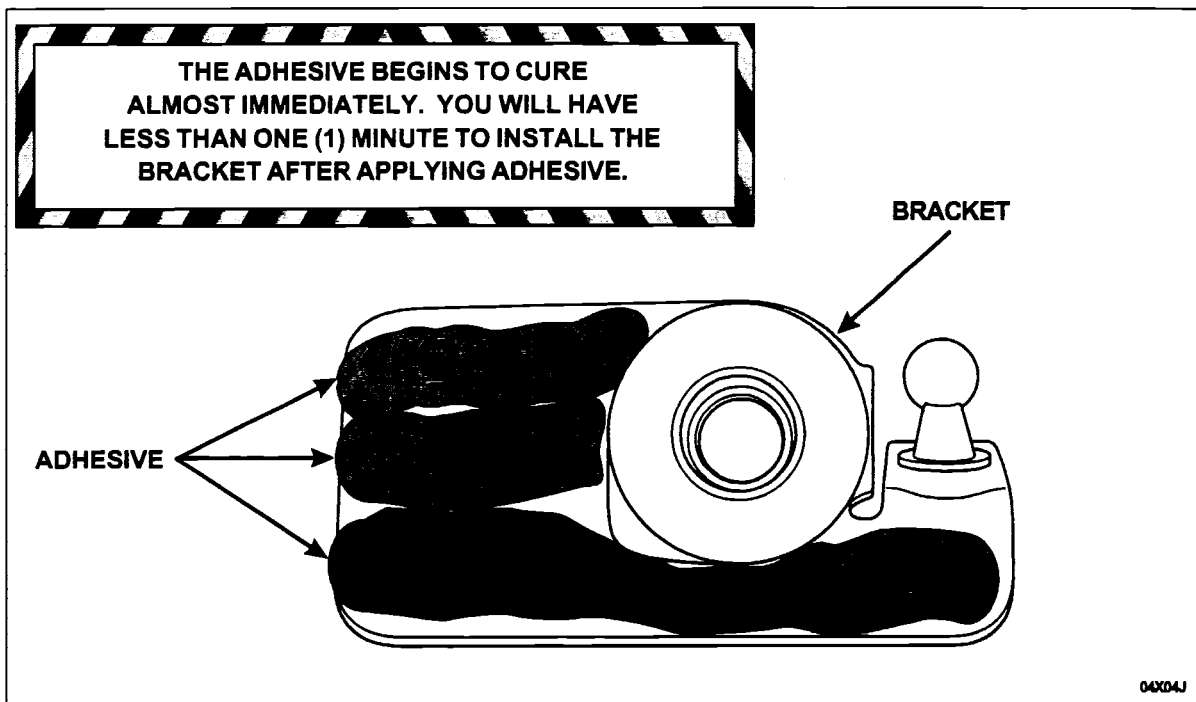

FIGURE 10



11. NOTE: Left side bolts and brackets have left-hand threads.

NOTE: Once the bracket is in position, DO NOT lift it from the glass. You may twist or turn the bracket slightly, but it must remain in contact with the glass to prevent the formation of air bubbles in the adhesive.

With the correct left-hand thread beauty bolt and plastic washer ready in one hand, position the *new* left-side bracket onto the glass and align it with the beauty bolt hole and parallel with the edge of the glass. Install the beauty bolt and snug it down hand tight.

CAUTION: While tightening the bolt, some adhesive will be squeezed out from under the bracket. DO NOT WIPE AWAY THE EXCESS ADHESIVE.

While holding the bracket nut with a 17-mm box or open-end wrench, tighten the bolt to 25 Nm (18 lb-ft). See Figure 11.

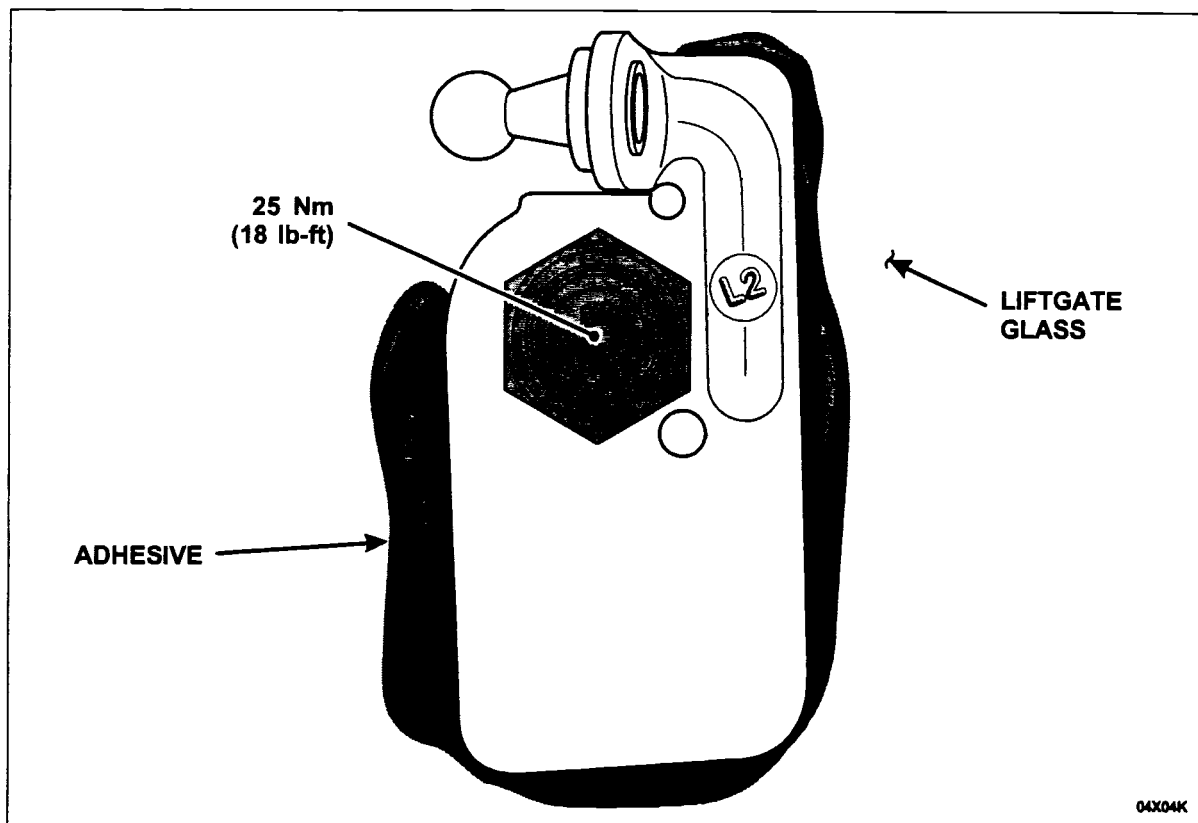

FIGURE 11

12. Once the *new* bracket is in place, make sure the edge of the bracket is parallel to the edge of the glass. If the bracket position needs to be adjusted, you may turn it using a 17-mm wrench. DO NOT separate the bracket from the glass once the bracket is in position.

CAUTION: Do not install the liftgate glass support struts until the adhesive has cured for a minimum of two (2) hours at 70°F or higher. If the vehicle must be moved to a much colder environment before two (2) hours has elapsed, cure time may increase substantially before the liftgate glass support struts can be reattached.



13. NOTE: Be sure to use a *new* mixer tip for each bracket.

Install a *new* trimmed mixer tip onto the adhesive cartridge, then dispense a 75-mm (3-in) bead of adhesive onto a piece of scrap cardboard to ensure the product is evenly mixed in the tip and is ready for application.

14. Apply three (3) **large** beads (9-10 mm in diameter) of adhesive to the backside of the *new* right-side bracket. See Figure 10.
15. With the correct right-hand thread beauty bolt and plastic washer ready in one hand, position the *new* right-side bracket onto the glass and align it with the beauty bolt hole and parallel with the edge of the glass. Install the beauty bolt and snug it down hand tight.

CAUTION: While tightening the bolt, some adhesive will be squeezed out from under the bracket. DO NOT WIPE AWAY THE EXCESS ADHESIVE.

While holding the bracket with a 17-mm box or open-end wrench, tighten the bolt to 25 Nm (18 lb-ft). See Figure 11.

16. Once the *new* bracket is in place, make sure the edge of the bracket is parallel to the edge of the glass. If the bracket position needs to be adjusted, you may turn it using a 17-mm wrench. DO NOT separate the bracket from the glass once the bracket is in position.

CAUTION: Do not install the liftgate glass support struts until the adhesive has cured for a minimum of two (2) hours at 70°F or higher. If the vehicle must be moved to a much colder environment before two (2) hours has elapsed, cure time may increase substantially before the liftgate glass support struts can be reattached.

17. Remove the jack stand, carefully close the glass making sure the striker is engaged in the latch, and allow the adhesive to cure for a minimum of two (2) hours at 21°C (70°F). The adhesive will cure at a slower rate with temperatures below 21°C (70°F).
18. After the adhesive has cured for two (2) hours, reattach the liftgate glass support struts before releasing the vehicle to the customer.



**Safety Recall 04S20
Dealer Questions and Answers**

Q1) Why do later built vehicles only need hinge replacement?

A1) Vehicles built after March 10, 2002 (SLAP) or March 3, 2002 (LAP) have an entirely different lift strut bracket design, and are not affected.

Q2) If the strut has come off the bracket, should the strut be replaced?

A2) No. Liftgate struts are not damaged when the strut comes off the bracket.

Q3.) What if the liftgate glass detached and caused damage to nearby components?

A3.) Call the Special Service Support Center at 1-800-325-5621 prior to performing any repairs when there is damage done to nearby components.

Q4) Some customers have experienced a cracked liftgate appliqué. Is this related to the recall?

A4) No, the appliqué is not related in any way to the issues addressed by this recall. Applique repairs are not covered by this recall.

Q5) When can I provide the customer with a rental vehicle?

A5) A rental vehicle is only authorized when:

- A vehicle arrives with a shattered back glass and a new glass must be ordered.
- Shop volume or service scheduling makes it impossible to store vehicles which require bracket replacement at 70° F or higher for two hours. It is anticipated that rental vehicles will only be required in limited circumstances.

NOTE: Rental vehicles are not covered under this program for vehicles which only require hinge replacement.

Q6) If the liftgate glass is broken and requires replacement, do the brackets on the new glass need to be replaced?

A6) No. The new glass comes with the revised brackets already in place.

Q7) When a new glass is ordered, does it come with new design hinges or old design hinges?

A7) The new glass comes with new design hinges.

Q8) What can customers do until parts are available?

A8) Customers will be advised to not use the liftgate glass. Please note that the full liftgate may continue to be used to access the rear compartment of the vehicle.

Q9) What if the customer arrives with the rear liftgate glass broken?

A9) Call the Special Service Support Center at 1-800-325-5621 prior to performing any repairs.

Q10) How will customers be advised when parts are available?

A10) Customers will receive a second notice advising them that parts are available and to contact their dealer for an appointment to have Safety Recall 04S20 performed on their vehicle. Dealers will be advised of parts availability prior to the second customer notice.



Frank M. Ligon
Ford Motor Company
P. O. Box 1904
Dearborn, Michigan 48121

September 2004

Safety Recall 04S20 - Vehicles built from Job #1 2002 through March 10, 2002 at St Louis Assembly Plant (SLAP) or through March 3, 2002 at Louisville Assembly Plant (LAP)

Mr. John Sample
123 Main Street
Anywhere, USA 12345

Your Vehicle Identification Number: 12345678901234567

This notice is sent to you in accordance with the requirements of the National Traffic and Motor Vehicle Safety Act.

Ford Motor Company has decided that a defect which relates to motor vehicle safety exists in certain 2002 Ford Explorer and Mercury Mountaineer vehicles.

We apologize for this situation and want to assure you that, with your assistance, we will correct this condition. Our commitment, together with Ford and Lincoln Mercury dealers, is to provide you with the highest level of service and support possible.

What is the issue?

In some of the affected vehicles, the liftgate window may drop unexpectedly when it is being operated. When the window drops it may strike a person nearby or the glass may break creating the potential for cuts or bruises.

What will Ford and your dealer do?

Effective Late November 2004: At no charge, dealers will replace both strut mounting brackets and both hinges on the liftgate glass with new design parts. We expect these new design parts will be available late November 2004. We will notify you when parts are available so you can contact your dealer for an appointment to have Safety Recall 04S20 performed on your vehicle.

How long will it take?

The time needed for this repair is less than one-half day. However, due to service scheduling requirements, your dealer may need your vehicle for a longer period of time. To ensure a proper repair, your dealer may also need your vehicle for a longer time when outside temperatures are very low.

What are we asking you to do?

WARNING: Until this recall has been performed, do not open or close your liftgate glass. The larger liftgate door is not affected by this recall, so you can still use it to access the rear compartment of your vehicle. **See the attached illustration for guidance.** When parts become available, we will notify you and ask you to call your dealer to request a service date for Recall 04S20. At that time, provide the dealer with the Vehicle Identification Number (VIN) of your vehicle. The VIN is printed near your name at the beginning of this letter.

If you do not already have a servicing dealer, you can access <http://www.genuinefilmservice.com> for dealer addresses, maps, and driving instructions.

Please note: Federal law requires that any vehicle lessor receiving this recall notice must forward a copy of this notice to the lessee within ten days.

Have you previously paid for this repair?

If you paid to remedy the issue addressed in this notice, you may be eligible for a refund either through your dealer or directly from Ford Motor Company.

To verify eligibility and expedite reimbursement, give your paid original receipt to your dealer. Refund requests, including all required documentation, may also be mailed to Ford at P.O. Box 6251, Dearborn, Michigan 48121-6251. Refund requests mailed to Ford may take up to 60 days to process.

Detailed information regarding eligibility for Ford's reimbursement program and documentation requirements may be obtained by contacting the Ford Customer Relationship Center at 1-866-436-7332. Owners who have previously paid for this repair are still eligible to have the recall described in this letter performed.

Have you changed your address or sold the vehicle?

If you have, please fill out the enclosed prepaid postcard and mail it to us so we can update our records. If you have sold the vehicle, the information you provide on the postcard will be used to notify the new owner about this recall.

Can we assist you further?

If you have difficulty getting your vehicle repaired promptly and without charge, please contact your dealership's Service Manager for assistance.

If you still have concerns, please contact the Ford Motor Company Customer Relationship Center and one of our representatives will be happy to assist you.

Call 1-866-436-7332. For the hearing impaired call 1-800-232-5952 (TDD).

Office Hours: (Eastern Time Zone)

Monday – Friday: 8AM – 8PM

Saturday: 9AM – 5:30PM

If you wish to contact us through the Internet, our address is:

www.ownerconnection.com

If you are still having difficulty getting your vehicle repaired in a reasonable time or without charge, you may write the Administrator, National Highway Traffic Safety Administration, 400 Seventh Street S. W., Washington, D. C. 20590 or call the toll free Auto Safety Hotline at 1-888-327-4236 or 1-800-424-9393.

Thank you for your attention to this important matter.

Sincerely,

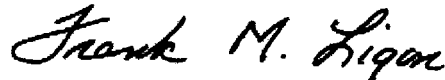

Frank M. Ligon
Director
Service Engineering Operations

**CUSTOMER INSTRUCTIONS
UNTIL REPAIRS ARE COMPLETED**

**DO NOT
OPEN/CLOSE GLASS**

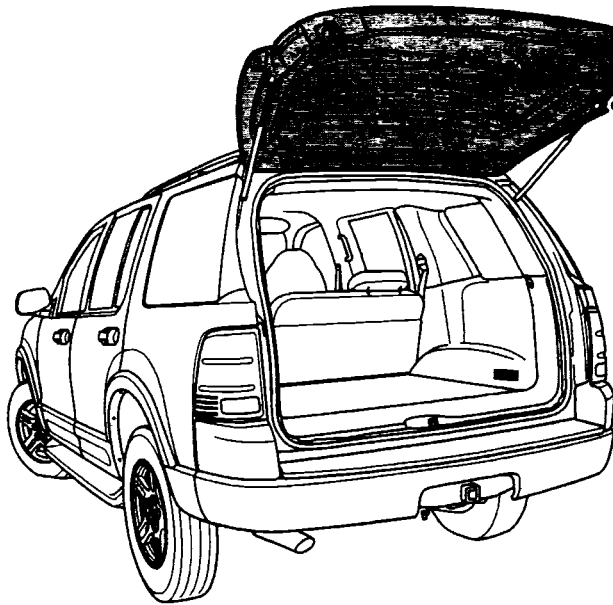
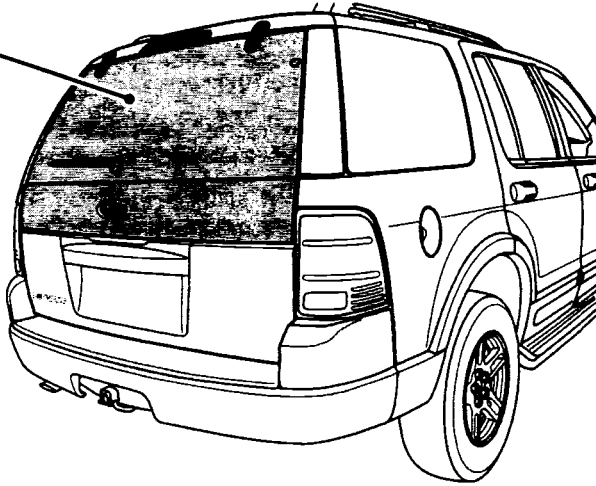

**OK TO
OPEN LIFTGATE**



Frank M. Ligon
Ford Motor Company
P. O. Box 1904
Dearborn, Michigan 48121

September 2004

Safety Recall 04S20 - Vehicles built from March 11, 2002 at St Louis Assembly Plant (SLAP) or March 4, 2002 at Louisville Assembly Plant (LAP) through June 23, 2003

Mr. John Sample
123 Main Street
Anywhere, USA 12345

Your Vehicle Identification Number: 12345678901234567

This notice is sent to you in accordance with the requirements of the National Traffic and Motor Vehicle Safety Act.

Ford Motor Company has decided that a defect which relates to motor vehicle safety exists in certain 2002 and 2003 Ford Explorer and Mercury Mountaineer vehicles.

We apologize for this situation and want to assure you that, with your assistance, we will correct this condition. Our commitment, together with Ford and Lincoln Mercury dealers, is to provide you with the highest level of service and support possible.

What is the issue?

In some of the affected vehicles, the liftgate window may drop unexpectedly when it is being operated. When the window drops it may strike a person nearby or the glass may break creating the potential for cuts or bruises.

What will Ford and your dealer do?

Effective Late November 2004: At no charge, dealers will replace both hinges on the liftgate glass with new design parts. We expect these new design parts will be available late November 2004. We will notify you when parts are available so you can contact your dealer for an appointment to have Safety Recall 04S20 performed on your vehicle.

How long will it take?

The time needed for this repair is less than one-half day. However, due to service scheduling requirements, your dealer may need your vehicle for a longer period of time.

What are we asking you to do?

WARNING: Until this recall has been performed, do not open or close your liftgate glass. The larger liftgate door is not affected by this recall, so you can still use it to access the rear compartment of your vehicle. **See the attached illustration for guidance.** When parts become available, we will notify you and ask you to call your dealer to request a service date for Recall 04S20. At that time, provide the dealer with the Vehicle Identification Number (VIN) of your vehicle. The VIN is printed near your name at the beginning of this letter.

If you do not already have a servicing dealer, you can access <http://www.genuineflmservice.com> for dealer addresses, maps, and driving instructions.

Please note: Federal law requires that any vehicle lessor receiving this recall notice must forward a copy of this notice to the lessee within ten days.

Have you previously paid for this repair?

If you paid to remedy the issue addressed in this notice, you may be eligible for a refund either through your dealer or directly from Ford Motor Company.

To verify eligibility and expedite reimbursement, give your paid original receipt to your dealer. Refund requests, including all required documentation, may also be mailed to Ford at P.O. Box 6251, Dearborn, Michigan 48121-6251. Refund requests mailed to Ford may take up to 60 days to process.

Detailed information regarding eligibility for Ford's reimbursement program and documentation requirements may be obtained by contacting the Ford Customer Relationship Center at 1-866-436-7332. Owners who have previously paid for this repair are still eligible to have the recall described in this letter performed.

Have you changed your address or sold the vehicle?

If you have, please fill out the enclosed prepaid postcard and mail it to us so we can update our records. If you have sold the vehicle, the information you provide on the postcard will be used to notify the new owner about this recall.

Can we assist you further?

If you have difficulty getting your vehicle repaired promptly and without charge, please contact your dealership's Service Manager for assistance.

If you still have concerns, please contact the Ford Motor Company Customer Relationship Center and one of our representatives will be happy to assist you.

Call 1-866-436-7332. For the hearing impaired call 1-800-232-5952 (TDD).

Office Hours: (Eastern Time Zone)

Monday – Friday: 8AM – 8PM

Saturday: 9AM – 5:30PM

If you wish to contact us through the Internet, our address is:

www.ownerconnection.com

If you are still having difficulty getting your vehicle repaired in a reasonable time or without charge, you may write the Administrator, National Highway Traffic Safety Administration, 400 Seventh Street S. W., Washington, D. C. 20590 or call the toll free Auto Safety Hotline at 1-888-327-4236 or 1-800-424-9393.

Thank you for your attention to this important matter.

Sincerely,

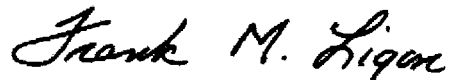

Frank M. Ligon

Director

Service Engineering Operations

**CUSTOMER INSTRUCTIONS
UNTIL REPAIRS ARE COMPLETED**

**DO NOT
OPEN/CLOSE GLASS**

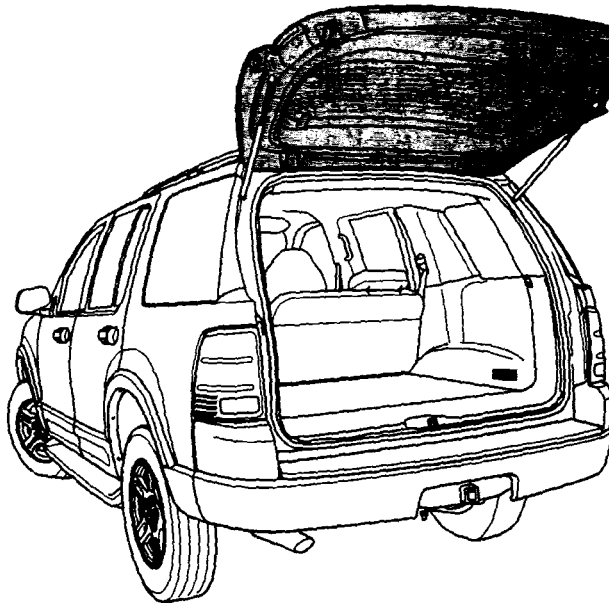
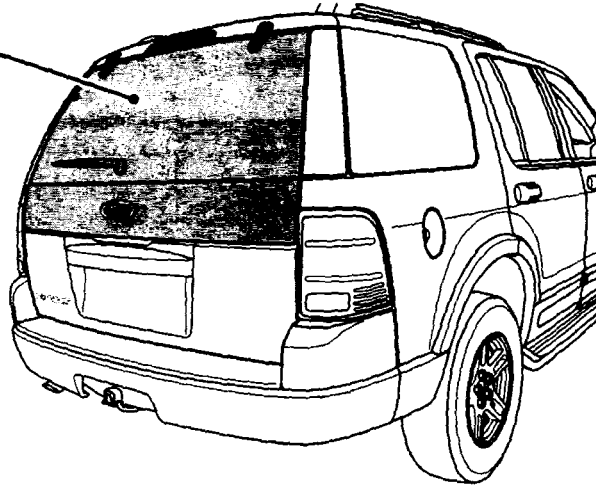

**OK TO
OPEN LIFTGATE**