

**NISSAN**

**NISSAN NORTH AMERICA, INC.**

Corporate Office  
18501 South Figueroa St  
Gardena, California 90248-4800  
Mailing Address: P.O. Box 191  
Gardena, California 90248-0191  
Telephone: 310.582.8111

RECEIVED

2004 SEP 24 A 10 30

OFFICE OF DEFECTS  
INVESTIGATION

September 23, 2004

Mr. George Person  
Chief, Recall Analysis Division  
Office of Defects Investigation  
Safety Assurance  
National Highway Traffic Safety Administration  
400 Seventh Street, S.W.  
Washington, D.C. 20590

Ref: 04V-408

Dear Mr. Person:

The enclosed communication is being provided pursuant to 49 CFR Part 573.6(c)(9).

Technical Compliance Department

Encl.

**RECALL CAMPAIGN BULLETIN**

Reference:

NTB04-105

Date:

September 22, 2004

**VOLUNTARY RECALL CAMPAIGN  
A/T COLUMN SHIFTER****CAMPAIGN I.D. # / NHTSA #: RU403 / 04V-408****APPLIED VEHICLE: 2004 Titan (A60)****APPLIED VIN: 1N6AA0\*\*\*4N604115 - 505574****1N6AA0\*\*\*4N527814 - 548997****NOTE: You MUST use Service Comm to confirm campaign eligibility.****INTRODUCTION**

Nissan has determined that some 2004 model year Nissan Titan vehicles may have a defect which relates to motor vehicle safety. There is a possibility that the transmission shift lever assembly for the column shifter may have been damaged during manufacture. The damage could eventually result in the failure of the portion of the assembly that holds the shift lever in the "Park" position when the key is not in the ignition or when the key is in the "Lock", "Off" or "Accessory" position. This would allow the shift lever to be capable of being moved from "Park" without the key or when the ignition is in a position other than "On". In some situations, the ability of the shift lever to be moved out of the Park position could result in rollaway of the vehicle and cause a crash. To prevent this condition from occurring, Nissan is conducting a Voluntary Safety Recall Campaign to replace the shift lever assembly.

**IDENTIFICATION NUMBER**

Nissan has assigned identification number RU403 to this campaign. This number must appear on all communications and documentation of any nature dealing with this campaign.

**NUMBER OF VEHICLES POTENTIALLY AFFECTED**

The number of vehicles potentially affected is approximately 5,600.

**DEALER RESPONSIBILITY**

It is the retailer's responsibility to check Service Comm for the campaign status on each vehicle falling within the range of this voluntary safety recall which for any reason enters the service department. This includes vehicles purchased from private parties or presented by transient (tourist) owners and vehicles in a dealer's inventory. Federal law requires that new vehicles in dealer inventory which are the subject of a safety recall must be corrected prior to sale. Failure to do so can result in civil penalties by the National Highway Traffic Safety Administration. While federal law applies only to new vehicles, Nissan strongly encourages dealers to correct any used vehicles in their inventory before they are retailed.

## SERVICE PROCEDURE

Replace the A/T Column Shifter as follows:

**NOTE:** Use suitable covers to protect upholstery, carpet, trim, etc. when performing this procedure.

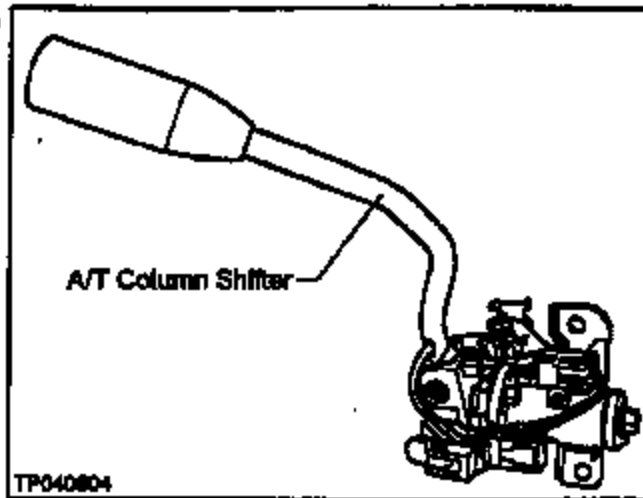

Figure 1

1. Apply the Parking Brake.
2. Remove two Screws and remove the Lower Instrument Panel (see Figure 2).
  - Use a Plastic Pry Tool to release any Securing Clips
  - Disconnect any Wire Harness Connectors from the Panel
  - Be careful, don't scratch/damage the Panel

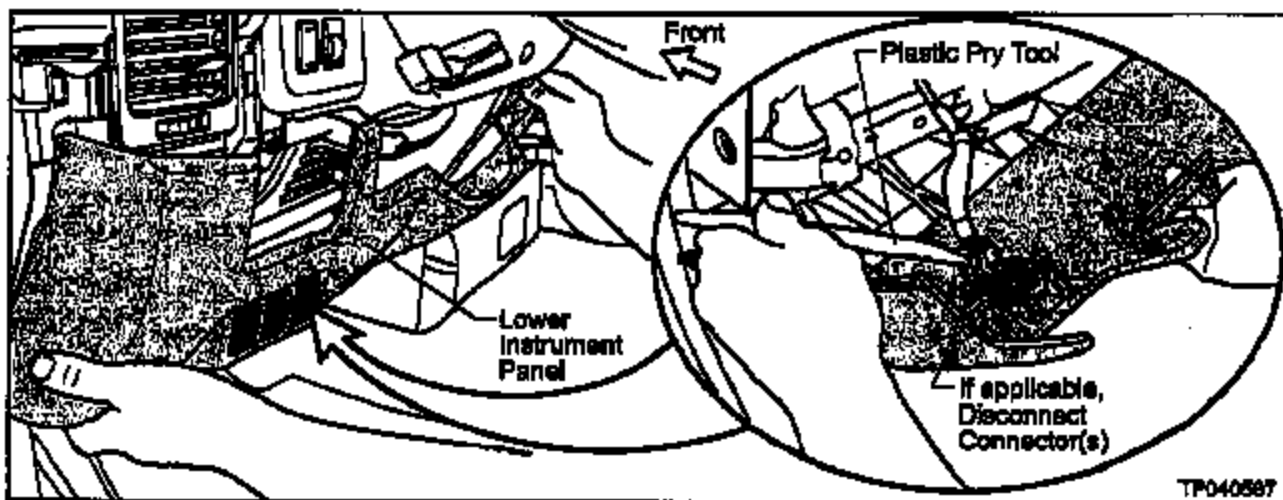

Figure 2

3. Remove four Bolts and remove the metal Knee Protector (see Figure 3).

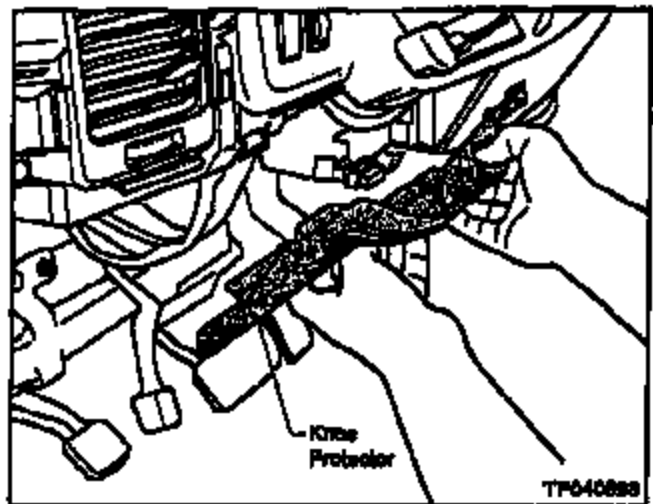

Figure 3

4. Tilt the Steering Wheel down.

5. Remove the Steering Wheel Tilt Knob (see Figure 4).

- To remove the Knob, press UP on the Tab on the underside of the Knob until the Pin lifts out of the Handle hole (see Figure 4).

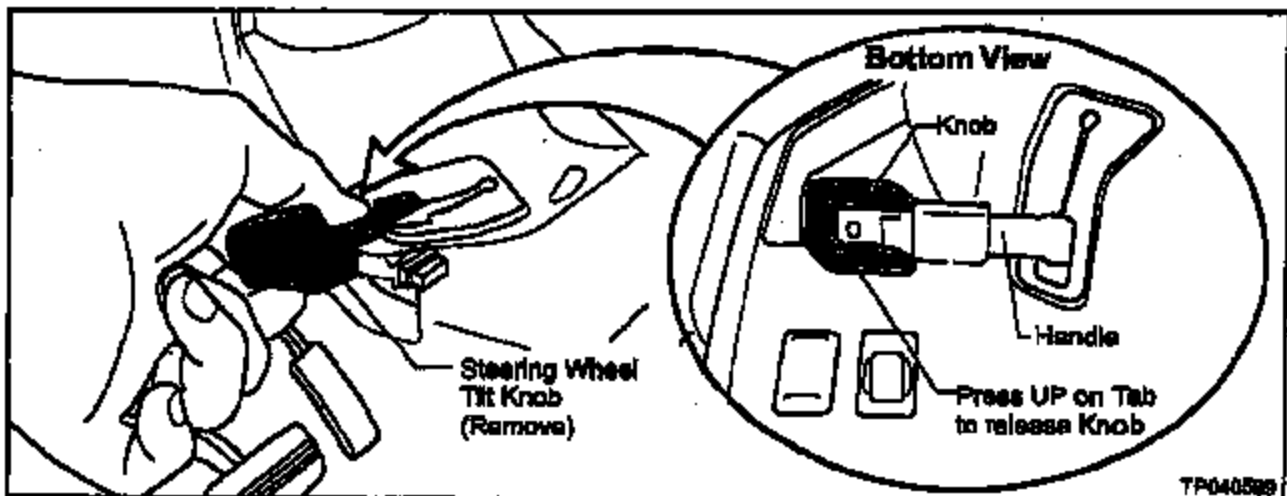

Figure 4

6. Turn the Ignition key to the "ON" position (engine OFF), depress the foot brake pedal, and place the shift lever in ("D") Drive.

- This will make it easier to remove the Upper Steering Column Cover.

7. Remove two Screws and carefully remove the Lower Steering Column Cover.

- If applicable, remove the Plastic Cover and Screw from the LH side of the Cover (see Figure 5)
- Be careful not to scratch/damage the Cover when removing it

8. Carefully remove the Upper Steering Column Cover.

- Slide the Cover off the end of the Shift Handle (see Figure 5)
- Be careful not to scratch/damage the Cover when removing it

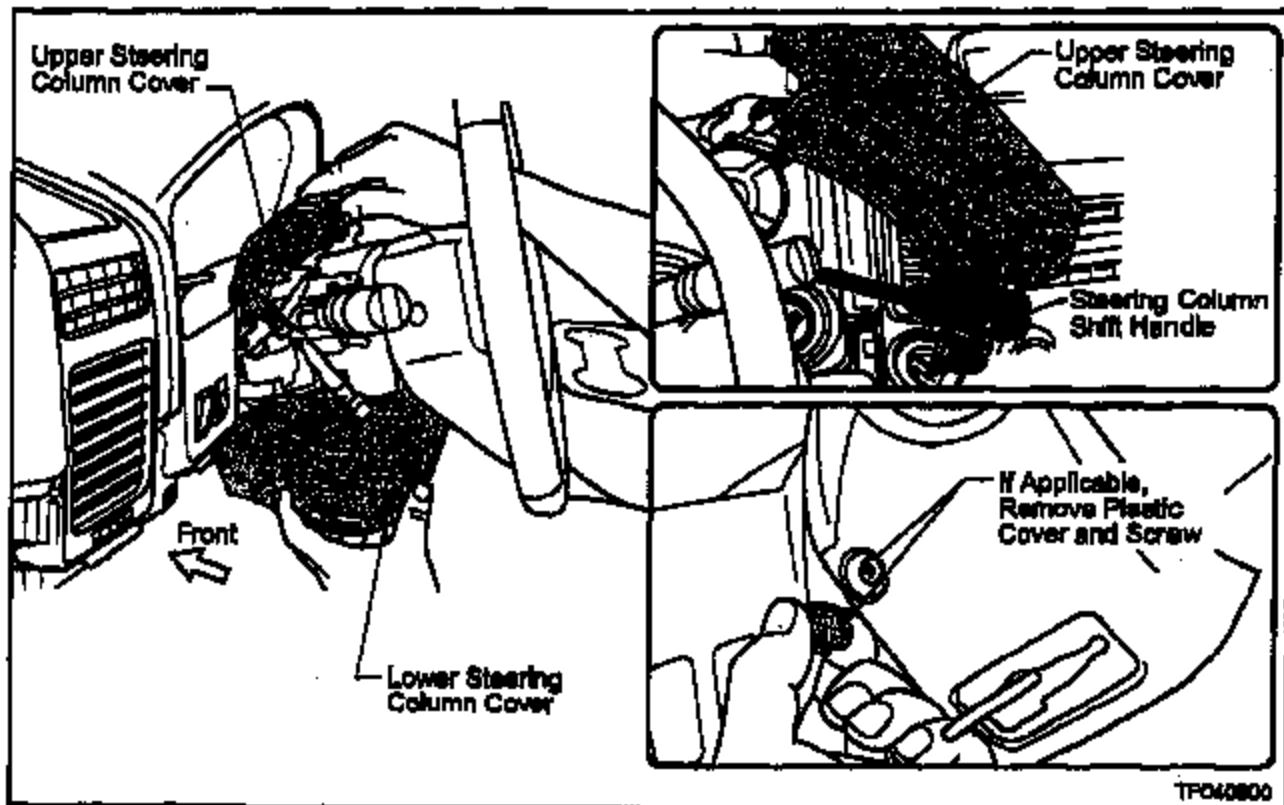

Figure 5

9. Depress the Foot Brake Pedal, place the Shift Lever in the ("P") Park position, and turn the Ignition key to the "OFF" position.

10. Disconnect the Ignition Key Interlock Rod from the Interlock Cable (see Figure 6).

- Squeeze the Locking Tabs, then pull the Rod out of the Cable

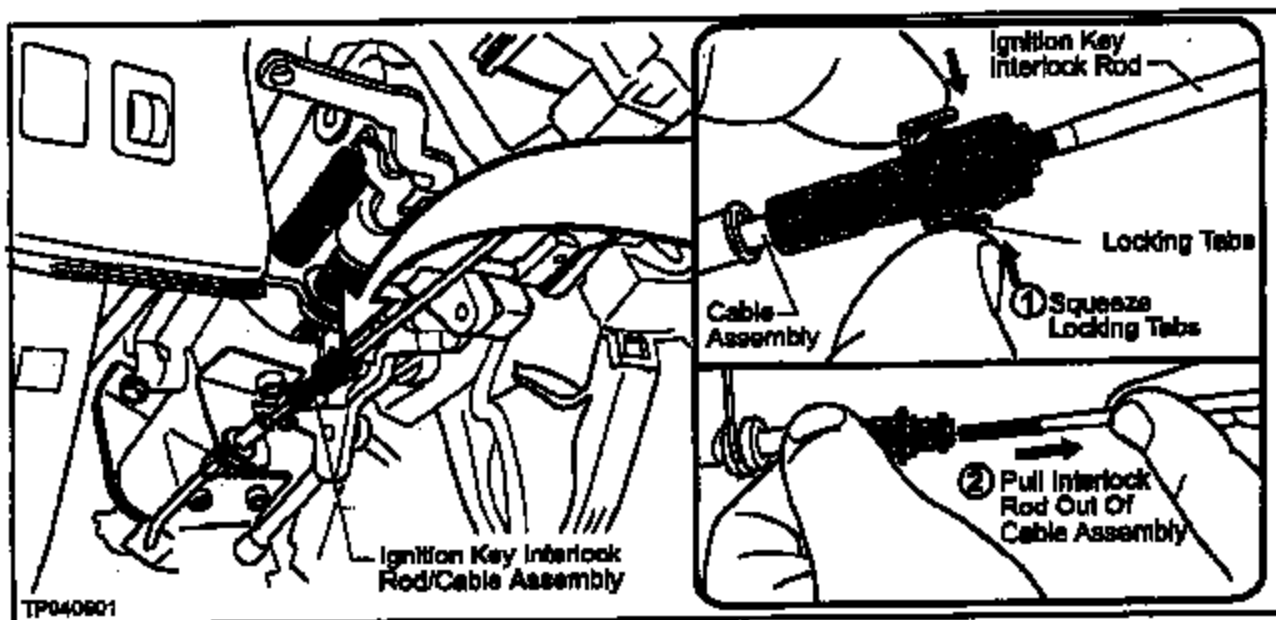

Figure 6

11. Disconnect the Shift Lock Control Unit Wire Harness Connector (see Figure 7).

- Use a small pick or screw driver to press on the connector lock tab. This will release the connector (see Figure 7).

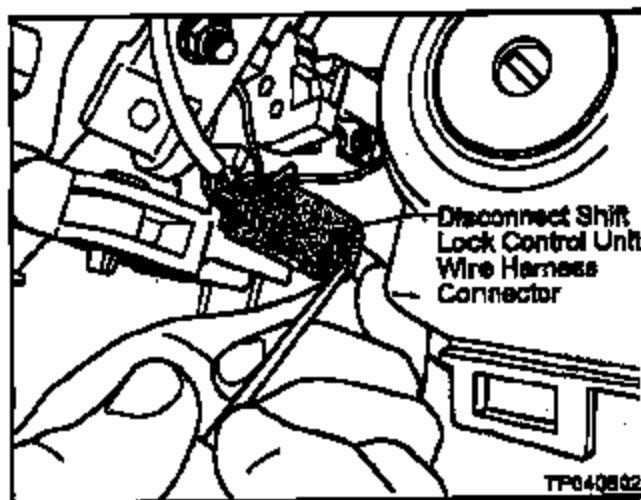
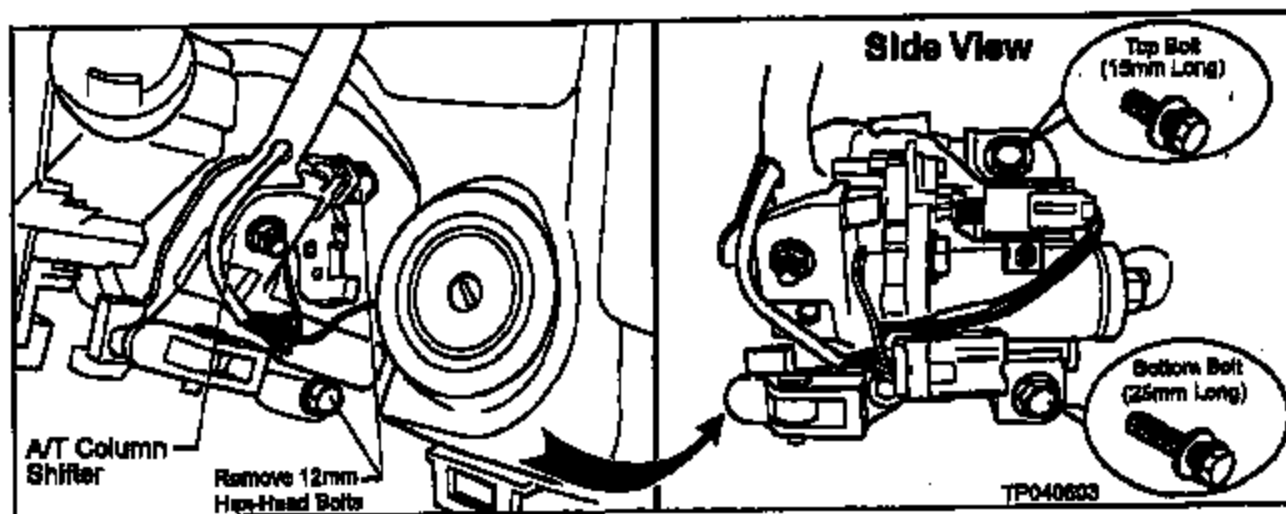

Figure 7

12. Remove the two 12mm Hex-Head Bolts and remove the original (old) A/T Column Shifter (see Figure 8).

- The top Bolt is 15mm long and the bottom Bolt is 25mm long



12. Install the new A/T Column Shifter (see Figure 8).

- The top Bolt is 15mm long and the bottom Bolt is 25mm long
- Tighten the Bolts to: 15 N-m (1.5 Kg-m, 11 ft-lb, 132 In-lb)

13. Re-install the Ignition Key Interlock Cable onto the Interlock Rod as follows (see Figure 9).

- Place the A/T Column Shifter in the ("P") Park position.
- Make sure the Interlock Rod is in its "rested" position.
- Squeeze the Locking Tabs on the Interlock Cable and slide the Cable over the Interlock Rod.
- Make sure the Locking Tabs slide towards the Interlock Rod to fully lock onto the Rod. Pull out on the Rod to make sure it's locked in place.

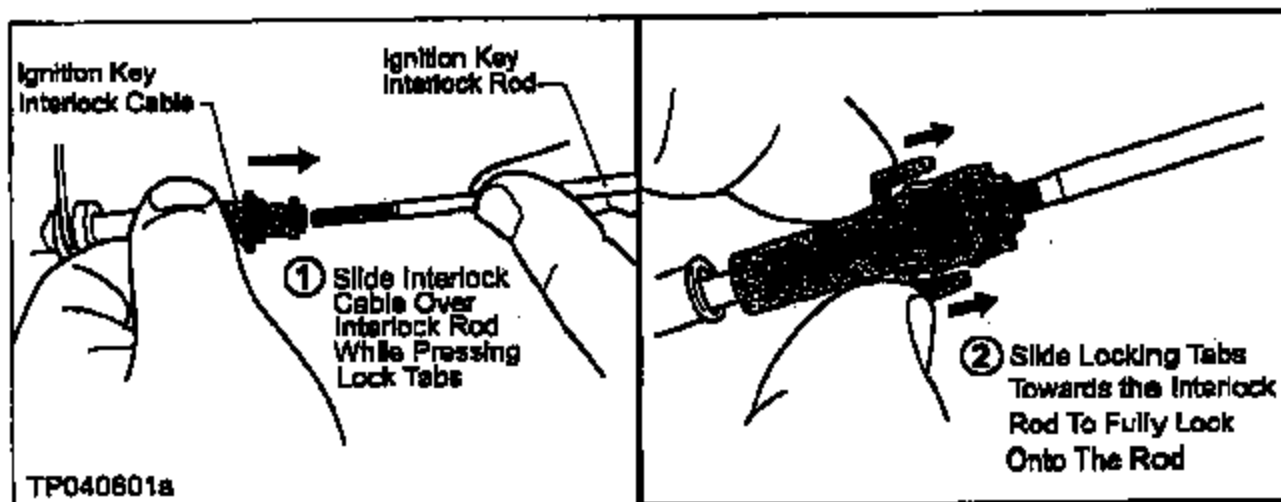

14. Re-connect the Shift Lock Control Unit Wire Harness Connector.

15. Turn the ignition key to the "ON" position (engine OFF), depress the foot brake pedal, and place the shift lever in ("D") Drive.

- This will make it easier to re-install the Upper Steering Column Cover (next step)

16. Re-install the Upper Steering Column Cover, then re-install the Lower Steering Column Cover.

- Be careful not to scratch/damage the Covers when re-installing them
- Depress the Foot Brake Pedal, place the Shift Lever in the ("P") Park position, and turn the ignition key to the "OFF" position.

17. Re-install the Steering Wheel Tilt Knob.

- Make sure the Pin is inserted into the Handle hole.

18. Re-install the metal Knee Protector.

- Tighten the four Bolts to: 5.9 N-m (.61 Kg-m, 4.4 ft-lb, 52.8 in-lb).

19. Re-install the Lower Instrument Panel.

- Make sure you re-connect any wire harness connectors to the Panel.

20. Check the Steering Column Tilt for proper operation.

21. Check the Ignition Key Interlock as follows:

**CAUTION: Make sure the Parking Brake is applied before performing this procedure.**

- a. Turn the Ignition Key to the "ON" position (engine OFF). Grab the shift handle and make sure the Shifter does NOT move from the ("P") Park position into gear.
- b. Press and hold the Brake Pedal. Then make sure the Shifter can be moved from ("P") Park into ("D") Drive.
- c. With the Shifter in ("D") Drive, release the Brake Pedal.
- d. Turn the Ignition Key to the "OFF" position (with Shifter in "D" Drive). Make sure you can NOT remove the Ignition Key from the Ignition Cylinder.
- e. Turn the Ignition Key to the "ON" position (engine OFF), press and hold the Brake Pedal, and move the Shifter to the ("P") Park position. Make sure the Ignition Key can be removed from the Ignition Cylinder.



22. Destroy the original (old) A/T Column Shifter as follows (see Figure 10).

**CAUTION:** Wear suitable hand and face protection when performing this procedure.

- a. Clamp the Shifter in a Vise
- b. Hit the Shifter with a Ball-Peen Hammer to break off the Interlock Shift Lever Mounting Point (see Figure 10).
- c. Discard the Shifter.

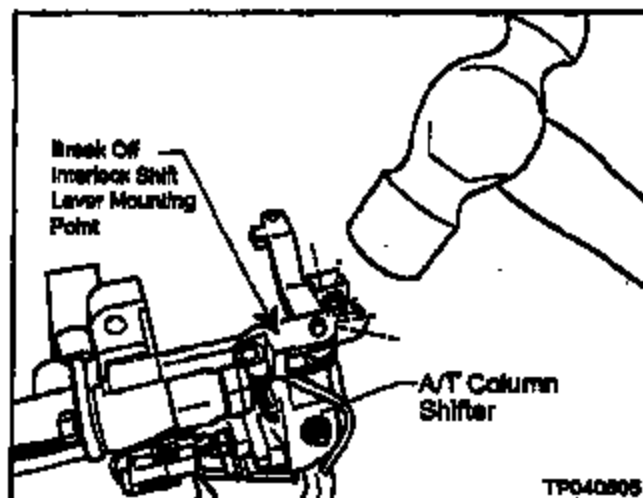

Figure 10

#### PARTS INFORMATION

| DESCRIPTION        | PART NUMBER | QUANTITY |
|--------------------|-------------|----------|
| A/T Column Shifter | 34101-7S000 | 1        |

#### CLAIMS INFORMATION

Submit a Campaign (CM) line claim using the following claims coding:

| DESCRIPTION            | OP CODE | FRT     |
|------------------------|---------|---------|
| RPL A/T Column Shifter | RU4030  | 0.7 hrs |

## **OWNER'S LETTER**

Dear Nissan owner:

This notice is sent to you in accordance with the requirements of the National Traffic and Motor Vehicle Safety Act. Nissan has decided that a defect that relates to motor vehicle safety exists in some 2004 model year Nissan Titan vehicles, equipped with a column shifter.

### **Reason for Recall**

The transmission shift lever assembly for the column shifter may have been damaged during manufacture. This could allow the shift lever to be moved out of the PARK (P) position without the key in the ignition or when the key is in the ignition switch in the LOCK, OFF or ACCESSORY position. In some situations, the ability of the shift lever to be moved out of the Park position could result in rollaway of the vehicle and cause a crash.

### **What Nissan Will Do**

The shift lever assembly will be replaced.

### **What You Should Do**

Contact your Nissan dealer at your earliest convenience in order to arrange an appointment to have your vehicle repaired. Please bring this notice with you when you keep your service appointment. Instructions have been sent to your Nissan dealer.

Always lock your vehicle and do not allow children to play in or around an unattended vehicle.

If the dealer fails, or is unable to make the necessary repairs free of charge, you may contact the National Consumer Affairs Office, Nissan North America, Inc. at P.O. Box 191, Gardena, California 90248-0191. The toll free number is 1-800-NISSAN1 (1-800-847-7261). You may also contact the Administrator of the National Highway Traffic Safety Administration, 400 Seventh Street SW, Washington, D.C. 20590 or call the toll free Safety Hotline at (888) 327-4236.

Federal regulations require that any vehicle lesser receiving this recall notice must forward a copy of this notice to the lessee within ten days.

Thank you for your cooperation. We are indeed sorry for any inconvenience this may cause you.