

04V-365

# SERVICE BULLETIN



B-059

August 27, 2004

## Safety Recall Code 0829 - BLAST FUEL VENT ROLLOVER VALVE ASSEMBLY

### GENERAL

See Figure 1. Buell Motorcycle Company has learned that certain 2004 model year Blast vehicles built between 1/6/2004 and 6/2/2004 have a fuel tank vent valve assembly that could malfunction. This condition could prevent sufficient fuel flow, which may cause the engine to unexpectedly stall. Accordingly, Buell Motorcycle Company is conducting a voluntary recall campaign to formally recall all potentially affected motorcycles. This condition will be remedied by replacing the fuel tank vent valve on all potentially affected vehicles. In addition to the above mentioned motorcycles a number of rollover valves and certain fuel tanks shipped from the P&A warehouse between 8/11/2003 and 6/3/2004 are suspect as well.

### Motorcycles Affected

This campaign involves 2004 P3 Blast vehicles built between 1/6/2004 and 6/2/2004.

### Customer Notification

Attached is a complete list of all vehicles shipped to you that are involved in this recall campaign. To protect the safety of our riders, it is our mutual responsibility to ensure that the recall service is performed on all affected motorcycles. Therefore, we strongly urge you to perform the recall service even if the motorcycle was not purchased from your dealership. You also are required to perform the recall service on all affected vehicles in your dealership inventory prior to delivering or leasing those vehicles.

If you are not sure that the safety recall service has been completed on a particular motorcycle, recall information is available on TALON and h-dnet.com.

### IMPORTANT NOTES

- **Because only registered owners as shown on the attached list will receive notification from us, we request that you contact any owners of vehicles still listed as unregistered by your dealership. Advise them of the safety recall and make arrangements for them to come in for recall service. We also require that you provide us with their names, addresses and VIN's as soon as possible to enable us to mail them an owner's letter, as required by the National Traffic and Motor Vehicle Safety Act (as amended).**
- **Because Buell Motorcycle Company has no record of who may have purchased/received affected vent valves or fuel tanks containing affected vent valves at the retail level, it is your responsibility to notify each of your customers.**

### Vent Valve Kit

#### NOTE

The kit below is for all affected Blast vehicles.

The Fuel Vent Valve recall kit (Part No. 94335Y) consists of:

**Table 1. Kit No. 94335Y**

Quantity	Part No.	Description
1	P0107.8C	Vent Valve
1	Y0305.8B	Cable Strap
1	P0106.8	O-ring

A shipment of Safety Recall Code 0829 kits, Part No. 94335Y, will contain approximately 65% of your total estimated kit requirements. Shipments will begin the week of August 30, 2004.

All kits will be shipped no charge, transportation paid. If additional kits are needed, fill in the attached order form and fax it to the Warranty Department at 414-343-8346.

#### NOTE

Do not send in orders for additional kits until you have received your one and only initial shipment and have determined your remaining kit requirements. Orders received before the initial shipment is complete will be discarded.

### IMPORTANT NOTE

In the interest of preserving customer safety and satisfaction, always check for outstanding recalls whenever any motorcycle is brought into your dealership for either maintenance or service.

ROUTING	SERVICE MANAGER	SALES MANAGER	PARTS MANAGER	LEAD TECHNICIAN	TECHNICIAN NO.1	TECHNICIAN NO. 2	TECHNICIAN NO. 3	TECHNICIAN NO. 4	RETURN THIS TO
INITIAL HERE									

©2004 Buell Motorcycle Company

**NOTE**

Buell Motorcycle Company reserves the right to conduct wave shipments in lieu of processing individual orders and/or adjusting order quantities, depending on the availability of replacement parts and dealers' recall completion rates.

To avoid an excess of unneeded kits in the field, please order responsibly.

**IMPORTANT NOTE**

**DO NOT ORDER THE RECALL KITS TO RESTOCK YOUR INVENTORY OR PROVIDE RETAIL REPLACEMENT! (Use Service Part No. P0107.8C)**

**Required Dealer Action**

**IMPORTANT NOTE**

**Obtain the 2004 Buell Blast Service Manual (Part No. 99492-04Y) for proper procedure. When reviewing the sections, be sure to take note of all warnings and cautions.**

**NOTE**

Perform the following procedures according to the guidelines given in the service manual for the model being serviced.

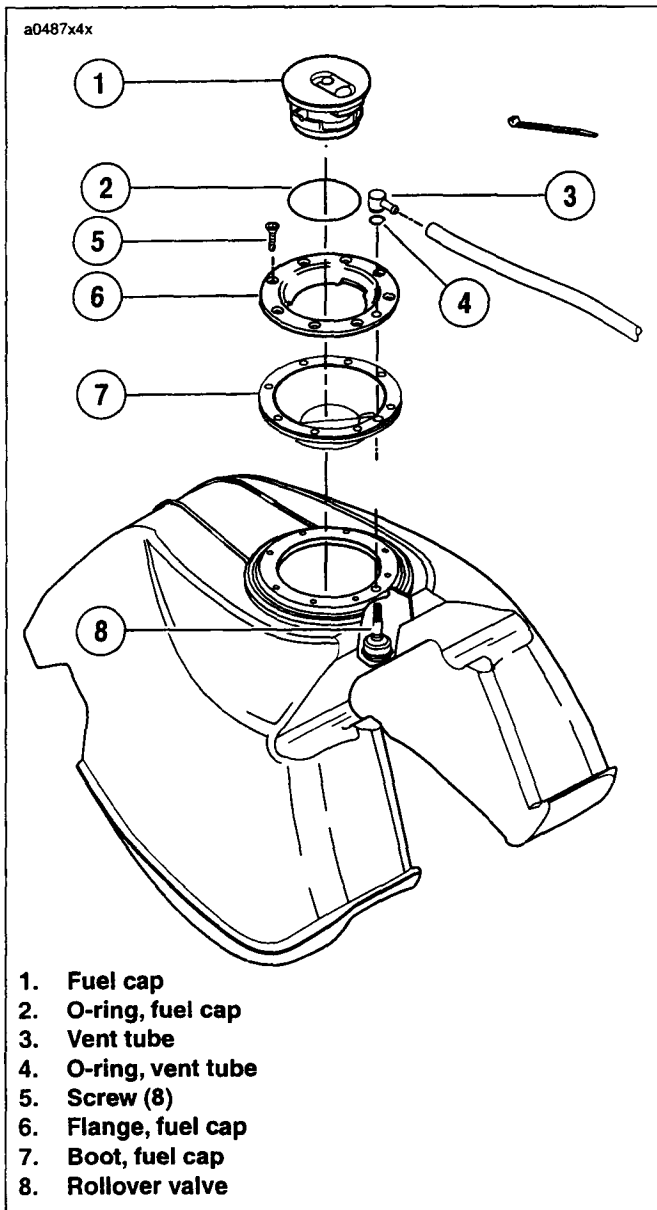

Figure 1. Rollover Valve And Fuel Cap Assembly

**CREDIT PROCEDURES -  
VEHICLE REPAIR, ORIGINAL  
EQUIPMENT VEHICLES INVOLVED**

**IMPORTANT NOTE**

**In order to receive credit in a timely manner, as well as to allow us to ensure our recall records are accurate and up to date, it is important that you submit completed recall cards to H-D immediately upon completion of the recall procedure.**

Upon completion of the recommended service, send in a properly completed Dealer Service Card, for each vehicle serviced. Write safety recall code "0829" on the card and place a "C" in the letter box.

Package the original rollover valve along with the properly completed Dealer Service Card and send it to: Buell Motorcycle Company, Warranty Return Department, 3801 W. Juneau Avenue, Milwaukee, WI 53208.

Upon receipt of the parts and a properly completed Dealer Service Card, you will be credited 0.8 hours labor, which includes 0.1 hour administration time, and also for return postage. No credit will be issued for parts as replacement parts were sent no charge, transportation paid.

**IMPORTANT NOTE**

**Dealers are not responsible for reimbursing customers who have replaced fuel tank vent valves prior to this recall. Advise customers that they may apply directly to Harley-Davidson for reimbursement of their costs following the procedures outlined in the attached Harley-Davidson Pre-Notification Remedy Reimbursement Program. Provide customer with copy of said document upon request.**

**CREDIT PROCEDURES-DEALER  
STOCK VALVES/VALVES SOLD  
OVER THE COUNTER NOT  
INSTALLED**

Remove all affected fuel vent rollover valves (Part No. P0107.8A) from your inventory and recover any uninstalled valves from your retail customers. To receive credit, complete an electronic warranty claim referencing Service Bulletin B-059 in the notes or comments section. Fill in the rest of the claim as follows:

**Table 2. Credit for Parts**

<b>Claim Type</b>	BDS
<b>Quantity</b>	See Note Below
<b>Event 1, Problem Part No.</b>	P0107.8A
<b>Part Description</b>	Fuel Tank Vent Rollover Valve
<b>Customer Concern Code</b>	9205
<b>Condition Code</b>	3109

**NOTE**

"Quantity" may vary depending upon what you have in stock and what is recovered from your retail customers. Upon receipt and processing of claim you will receive a bar-coded label requiring return of all affected valves, Part No. P0107.8A. In order to receive credit, part must be returned by due date on bar-coded label.

**IMPORTANT NOTE**

**DO NOT ORDER THE RECALL KITS TO RESTOCK YOUR INVENTORY OR PROVIDE RETAIL REPLACEMENT! (Use Service Part No. P0107.8C)**

**CREDIT PROCEDURES -  
INSTALLED AFFECTED TANKS AND  
VALVES**

Upon removing all affected installed vent valves and vent valves from affected tanks, complete an electronic warranty claim for each vehicle serviced. Reference Service Bulletin B-059 in the notes or comments section. Fill in the rest of the claim as follows:

**Table 3. Vehicle Repair-  
Installed Over the Counter Parts**

<b>Claim Type</b>	BMC/BGW*
<b>Quantity</b>	0
<b>Event 1, Problem Part No.</b>	P0107.8A
<b>Quantity Additional Parts</b>	1
<b>Replacement Part Nos.</b>	P0107.8C-Vent Valve
	Y0305.8B-Cable Strap
	P0106.8-O-ring
<b>Part Description</b>	Fuel Tank Vent Rollover Valve
<b>Primary Labor Code</b>	2569
<b>Time</b>	0.8
<b>Customer Concern Code</b>	9205
<b>Condition Code</b>	3109

**NOTE**

\*This procedure will require a VIN (use BMC if vehicle is within factory warranty, use BGW if vehicle is outside of factory warranty).

Upon receipt and processing of claim you will receive a bar-coded label requiring return of Part No. P0107.8A. In order to receive credit, part must be returned by due date on bar-coded label. When parts are returned, you will be credited as indicated in Table 3.

**IMPORTANT NOTE**

**DO NOT ORDER THE RECALL KITS TO RESTOCK YOUR INVENTORY OR PROVIDE RETAIL REPLACEMENT! (Use Service Part No. P0107.8C)**

# CREDIT PROCEDURES - REPAIR OF TANKS IN DEALER STOCK

Remove and replace all affected fuel vent rollover valves from tanks in stock (Part No. P0107.8A). To receive credit, complete an electronic warranty claim referencing Service Bulletin B-059 in the notes or comments section. Fill in the rest of the claim as follows:

**Table 4. Repair of Tanks in Dealer Stock**

<b>Claim Type</b>	BDS
<b>Quantity</b>	0
<b>Event 1, Problem Part No.</b>	P0107.8A-Vent Valve
<b>Additional part needed</b>	P0106.8-O-ring
<b>Quantity,</b>	1
<b>Part Description</b>	Fuel Tank Vent Rollover Valve
<b>Primary Labor Code</b>	Leave Blank
<b>Detail Labor Code</b>	2569
<b>Time</b>	All: 0.7 hr
<b>Customer Concern Code</b>	9205
<b>Condition Code</b>	3109

**NOTE**

*A separate claim needs to be completed for each tank repaired.*

Upon receipt and processing of claim you will receive a bar-coded label requiring return of affected valve from tank. In order to receive credit, part must be returned by due date on bar-coded label. When parts are returned, you will be credited as indicated in Table 4.

**IMPORTANT NOTE**

**DO NOT ORDER RECALL KITS TO REPAIR TANKS IN YOUR INVENTORY! (Use Service Part No. P0107.8C)**





**BUELL MOTORCYCLE COMPANY**  
3700 WEST JUNEAU AVE. MILWAUKEE, WI 53201  
414.342.4680 | buell.com

**SAMPLE COPY**

Dear Buell Motorcycle Owner:

This notice is being sent to you in accordance with the requirements of the National Traffic and Motor Vehicle Safety Act.

Buell Motorcycle Company has decided that a defect, which relates to motor vehicle safety, exists on certain 2004 Buell Blast Model Year Motorcycles built between January 6, 2004 and June 3, 2004. A defect involving the fuel vent rollover valve exists. This defect could cause the engine to shut down without notice, leading to a crash involving injuries or death.

Our records indicate that you purchased one of the motorcycles involved in this safety recall identified by the VIN (Vehicle Identification Number) shown on this letter.

**We strongly urge you to take your motorcycle to your dealer to have the appropriate service performed as soon as possible. If you had the defect, which is subject of this letter, remedied prior to receiving this letter, you may be eligible for reimbursement by Buell for your remedy costs. If you have incurred such pre-recall notice letter costs, please refer to the enclosure in this mailing which presents all of the details, including coverage and limitations, of the Buell Motorcycle Company reimbursement plan. Should you choose to ride your motorcycle prior to this service, we urge you to be aware of this condition.**

Please contact your Buell motorcycle dealer immediately and arrange an appointment to have your vent valve replaced. The dealer labor time to perform this service takes approximately less than 1 hour and the parts and labor will be free of charge to you. Parts should be available at your dealership approximately the week of August 30, 2004.

To verify that the service has been completed, Dealer will ask you to sign a recall claim. If you have sold your motorcycle, please forward the appropriate information about your purchaser to us. This will enable us to contact him/her and advise that person of this recall. Also, Federal regulation requires that any vehicle lessor receiving this recall notice must forward a copy of this notice to the lessee within ten days.

If you take your motorcycle to your dealer on a mutually agreed upon date and he does not perform the required service to your satisfaction, please contact Buell Motorcycle Company for

immediate assistance at the address or telephone number listed on this letterhead. If your dealer or Buell Motorcycle Company fails or is unable to remedy your motorcycle without charge within a reasonable time, you may wish to inform the Administrator, The National Highway Traffic Safety Administration, 400 Seventh Street, SW, Washington, DC 25090, or call the toll-free Auto Safety Hotline at 1-888-DASH-2DOT or contact NHTSA at [www.NHTSA.DOT.GOV](http://www.NHTSA.DOT.GOV).

We regret any inconvenience this may cause you, but we are initiating this action in the interest of your personal safety and satisfaction with our products. Thank you for your cooperation.

Sincerely,

Buell Motorcycle Company

**Buell Pre-Notification  
Remedy Reimbursement Program**

**Recall Summary**

(1) Buell Motorcycle Company is recalling certain 2004 Model Year Buell Blast motorcycles built between January 6, 2004 and June 3, 2004. Our records indicate that you purchased one of these motorcycles covered in this recall campaign. The defect in this recall condition involves the fuel vent rollover valve, which was designed to allow air to replace fuel in the tank during operation. This valve could malfunction thereby starving the engine for fuel. This situation could cause the vehicle to shut down without warning, which could lead to a crash, causing possibility of death or injury.

**Reimbursement Program**

(2) Our program for reimbursing a claimant who incurred costs prior to this recall for a remedy involving the defect which is the subject of this recall is as follows: subject to the limitations and qualifications noted below, we will reimburse the lesser of the dollar amount you paid for the remedy or your cost of remedy parts [at the Buell list price for related, authorized parts], labor at local rates, and associated costs such as taxes and disposal fees.

Our remedy in this recall involves replacing the vent valve. This is the only type of pre-notification remedy eligible for reimbursement consideration.

### **Time Limitation**

(3) The covered pre-recall remedy of your motorcycle must have occurred no later than September 3, 2004.

### **Exclusions**

(4) Buell's Pre-Notification Remedy Reimbursement Program does not include reimbursement:

(a) for costs incurred while our original warranty, or an extended warranty as to which we gave written notice in either case, was in effect and would have provided a free remedy (without any consumer payment) of the problem involved in the recall, unless our authorized dealer or representative denied warranty coverage to you or the warranty repair did not remedy the problem involved in the recall;

(b) for a pre-notification remedy which was not of the same type as the Buell recall remedy, which is replacing the vent valve.

(c) for a pre-notification remedy that did not address the defect involved in the recall;

(d) for a pre-notification remedy that was not reasonably necessary to correct the defect involved in the recall;

(e) for a pre-notification remedy involving a motorcycle first purchased more than 10 calendar years before the recall notice letter in this recall campaign was provided to owners or purchasers by Buell; or

(f) for insufficient documentation of your claim for pre-notification reimbursement, as specified immediately below. If this is the case, you will be given an opportunity to resubmit the claim with the complete information.

### **Required Claim Documentation**

- (5) To process your claim, Buell must have:
- (a) your name and mailing address;
  - (b) the make, model, model year and vehicle identification number (VIN) of your motorcycle;
  - (c) the recall campaign number (you may provide either the NHTSA or Buell recall number);
  - (d) name of the owner or purchaser of the motorcycle with the recall at the time the pre-notification remedy was obtained;
  - (e) a copy of the receipt for the pre-notification remedy, which, in the case of a replacement of a motorcycle part or component, a copy of the receipt identifying the part, etc. involved and stating the total amount paid for the part, etc. which replaced the defective item; and
  - (f) if the pre-notification remedy was obtained when your motorcycle could have been remedied at no charge under a Buell original or extended warranty, documentation indicating that our authorized dealer or facility either refused or failed to remedy the recall problem under our warranty program.

### **Where to File a Claim**

- (6) Claims for reimbursement, with the requisite documentation as itemized above, should be mailed to:

Buell Motorcycle Company  
Attn: Customer Service  
3900 W. Juneau Avenue  
Milwaukee, WI 53208

**Call Us With Your Questions**

(7) It is as important to us as it is to you that you understand the terms of our pre-notification reimbursement program. If you have any questions about the program or its possible application to you, please call us at 1-414-343-8400.

As always, Buell stands behind its products and wants to assure your continued satisfaction with your Buell motorcycle.

Buell Motorcycle Company