

*Ford Motor Company*

James P. Vondale, Director  
Automotive Safety Office  
Environmental & Safety Engineering

July 20, 2004

Mr. George Person, Chief  
Recall Management Division (NVS-215)  
Office of Defects Investigation  
National Highway Traffic Safety Administration  
400 Seventh Street, S.W.  
Washington, DC 20590

Dear Mr. Person:

**Subject: Safety Recall 04V-331  
(Ford Number 04S19)**

Pursuant to the requirements set forth in Part 573 of Title 49 of the Code of Federal Regulations -- Defect and Noncompliance Reports, Ford Motor Company is submitting a true or representative copy of information that relates directly to the subject campaign.

Attached are dealer and owner letters issued by Ford Customer Service Division regarding a recall of certain 2004 model year Ranger pickup trucks. Specific details were submitted to you in a letter dated July 6, 2004. Owner notification letters were mailed on July 19, 2004.

Sincerely,



J. P. Vondale

Attachment(s)  
04S19 Dealer-Owner Bulletin





Frank M. Ligon  
Director  
Service Engineering Operations  
Ford Customer Service Division

Ford Motor Company  
P. O. Box 1904  
Dearborn, Michigan 48121

July 2004

**TO:** All U.S. Ford and Lincoln Mercury Dealers

**SUBJECT:** **DEMONSTRATION/DELIVERY HOLD - Safety Recall 04S19:**  
Certain 2004 Model Year Ford Ranger Regular Cab Pickup Trucks  
Frame Rail Inspection

**AFFECTED VEHICLES**

Certain 2004 model year Ford Ranger regular cab pickup trucks built at the Twin Cities Assembly Plant from June 2, 2004 through June 23, 2004. Affected vehicles are identified in OASIS. In addition, for a list of vehicles assigned to your dealership, visit <https://web.fsavinlists.dealerconnection.com>. This information will be available on July 5, 2004.

**REASON FOR THIS SAFETY RECALL**

In some of the affected vehicles, it may be possible that the frames on short and long wheel base regular cab models have center rail section flanges that were not formed properly. In the event of a collision, an improperly formed center rail section could potentially puncture the fuel tank, resulting in a fuel leak. A fuel leak in the presence of an ignition source could result in a fire.

**SERVICE ACTION**

**DO NOT DRIVE, DEMONSTRATE OR DELIVER** any of the vehicles involved in this recall until they have been inspected per Attachment III. Vehicles that pass the inspection may be released; if a vehicle does not pass inspection, call the Special Service Support Center at 1-800-325-5621.

**OWNER NOTIFICATION MAILING SCHEDULE**

Owners of record will be notified via first-class mail the week of July 12, 2004. Please note that dealers should inspect any affected vehicles that arrive at their dealerships, whether or not the customer has received a letter.

**ATTACHMENTS**

Attachment I: Administrative Information  
Attachment II: Labor Allowances and Parts Ordering Information  
Attachment III: Technical Information  
Customer Notification Letter – To be provided week of July 12, 2004

**QUESTIONS?**

Claims Information: ..... 1-800-423-8851  
Special Service Support Center (Dealer Only) Questions: ..... 1-800-325-5621

Sincerely,

Frank M. Ligon

**DEMONSTRATION / DELIVERY HOLD: Safety Recall 04S19**  
Certain 2004 Model Year Ford Ranger Regular Cab Pickups  
Frame Rail Inspection

**OASIS ACTIVATED?** Yes. OASIS will be activated by July 2, 2004.

**FSA VIN LIST ACTIVATED?** Yes

Available through FMCDealer.com or at <https://web.fsavinlists.dealerconnection.com> July 5, 2004.

**STOCK VEHICLES**

Inspect all affected stock vehicles before demonstrating or delivering.

**SOLD VEHICLES**

- Immediately contact any of your affected owners and schedule an inspection date. Inspect other affected vehicles identified in OASIS, which are brought to your dealership.
- Owners of affected vehicles will be notified the week of July 12, 2004 and directed to dealers for inspection.

**TITLE BRANDED / SALVAGED VEHICLES**

Affected title branded and salvaged vehicles are eligible for this recall.

**RELATED DAMAGE**

Related damage claims will not be accepted for this program.

**ADDITIONAL LABOR TIME**

Requests for additional labor time will not be accepted.

**OWNER REFUNDS**

Refunds are not authorized for this program.

**RENTAL VEHICLES**

Call the Special Service Support Center at 1-800-325-5621 if an affected vehicle, already in customer possession, is found to have an improperly formed frame rail flange. Ford will pay for a rental vehicle except for fuel and insurance, which will be at the owner's expense.

**CLAIMS PREPARATION AND SUBMISSION**

- Enter claims using Direct Warranty Entry (DWE).
- Refer to ACESII manual for claims preparation and submission information.

**DEMONSTRATION / DELIVERY HOLD: Safety Recall 04S19**  
Certain 2004 Model Year Ford Ranger Regular Cab Pickups  
Frame Rail Inspection

**LABOR ALLOWANCES**

<b>Description</b>	<b>Labor Operation</b>	<b>Labor Time</b>
Inspect Driver's Side Frame Rail	04S19A	0.2 Hours
Inspect Driver's Side Frame Rail and call SSSC	04S19E	0.4 Hours

**PARTS INFORMATION**

Parts are not applicable for this program.

## CERTAIN 2004 MODEL YEAR RANGER VEHICLES — FRAME RAIL INSPECTION

### OVERVIEW

This program involves an inspection of the inboard side of the driver side center and rear frame rails. There are three (3) suspect areas of the frame rail to be inspected. At these areas, the frame rail lower flange lip may not have been formed correctly. See Figure 1.

- At the forward and center area, the frame flange lip should be rolled UP.
- At the rear area, the frame flange lip should be rolled DOWN.

For a vehicle to pass inspection, all flange areas must be properly formed. If any portion of the suspect areas of the frame is formed incompletely or incorrectly, the vehicle should be held, and the Special Service Support Center should be notified by calling 1-800-325-5821.

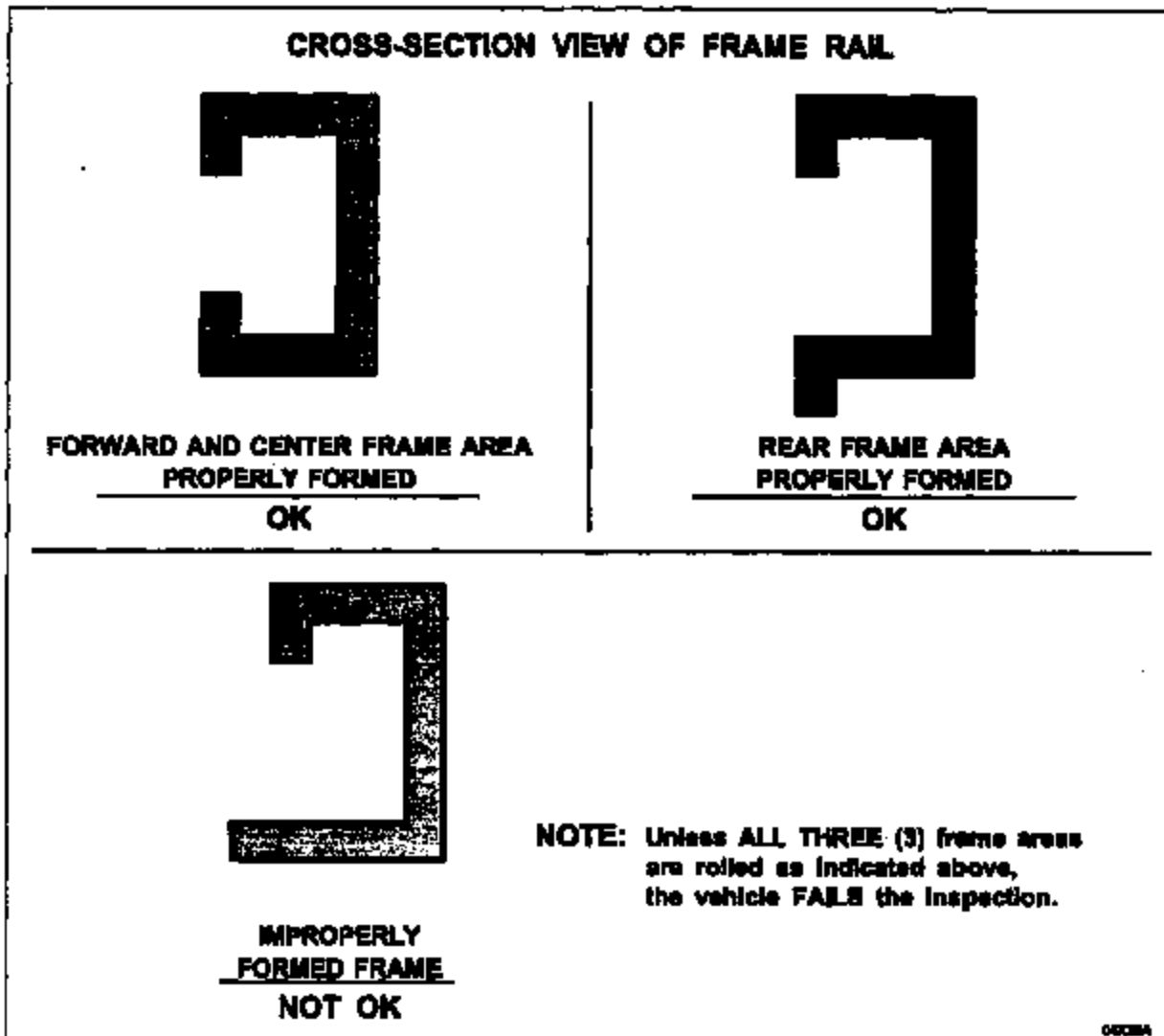

FIGURE 1



## INSPECTION

1. Raise the vehicle on a hoist. Note: Do not place the hoist arms on the driver side frame rail near the fuel tank or your view of the inspection area may be obstructed.
2. Inspect the three (3) suspect areas on the inboard side of the frame rail near the fuel tank. Each area must be rolled along the entire length of the flange. See Figures 2 and 3.
  - If the flange is properly formed, release the vehicle.
  - If the flange is not properly formed, call the Special Service Support Center at 1-800-325-5621 for further instructions.

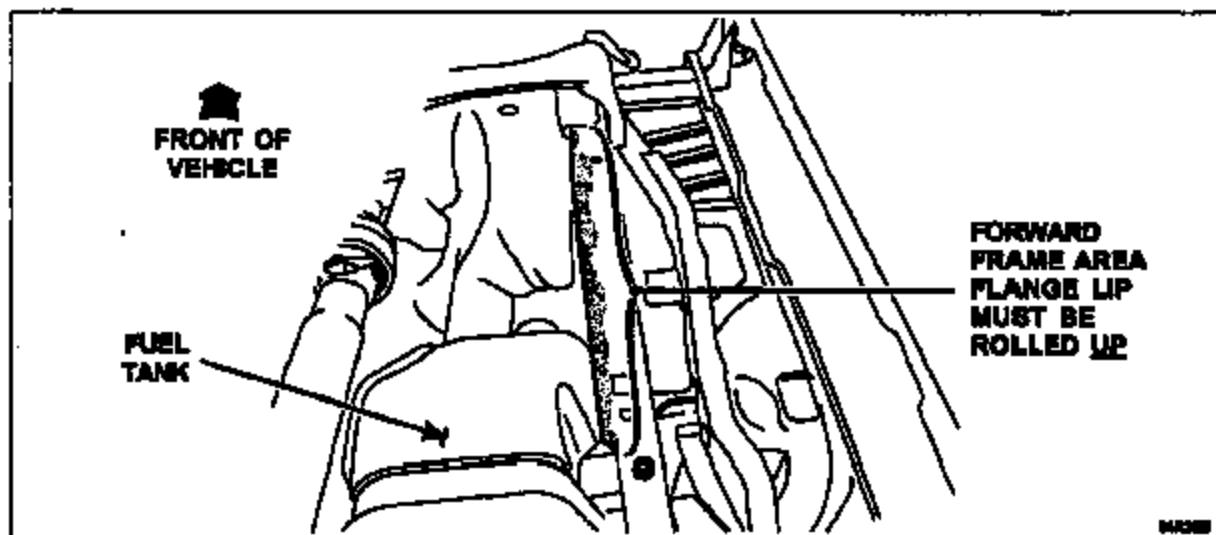

FIGURE 2

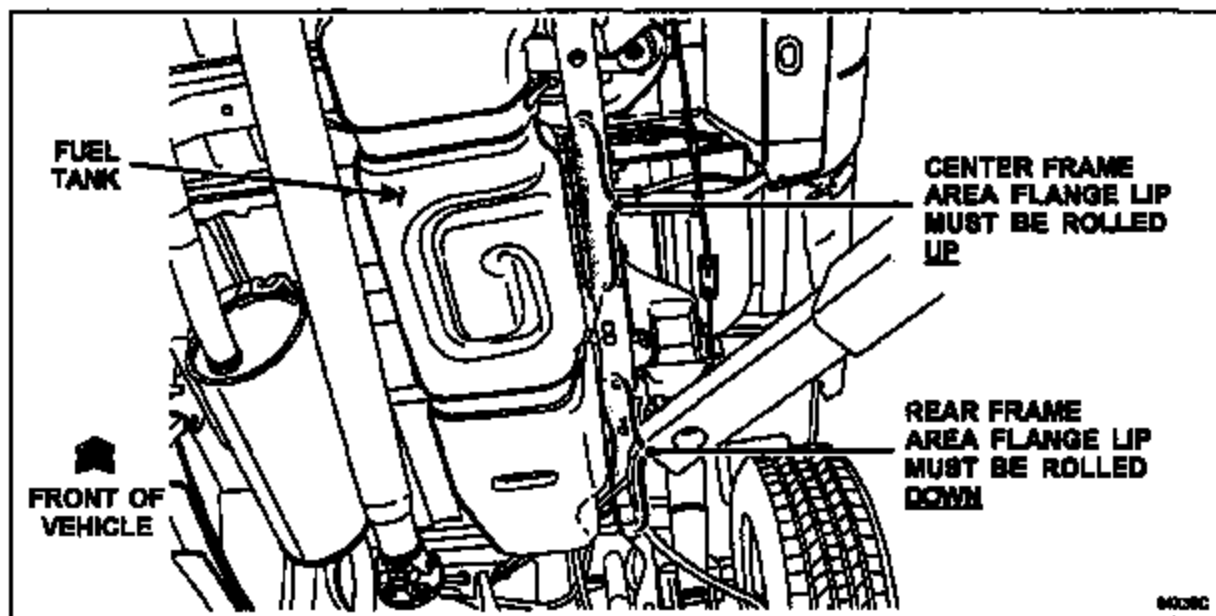

FIGURE 3





Frank M. Ligon  
Director  
Service Engineering Operations  
Ford Customer Service Division

Ford Motor Company  
P. O. Box 1904  
Dearborn, Michigan 48121

July 2004

**TO:** All U.S. Ford and Lincoln Mercury Dealers

**SUBJECT:** **DEMONSTRATION/DELIVERY HOLD - Safety Recall 04S19: Supplement #1**  
Certain 2004 Model Year Ford Ranger Regular Cab Pickup Trucks  
Frame Rail Inspection

**Ref:** **DEMONSTRATION/DELIVERY HOLD - Safety Recall 04S19:**  
Certain 2004 Model Year Ford Ranger Regular Cab Pickup Trucks  
Frame Rail Inspection

**New!**

**PURPOSE OF THIS SUPPLEMENT**

- Advise dealers that Customer Letters will be mailed and available to dealers on July 19, 2004.
- Advise dealers that units that do not pass inspection will not be repaired.
- Advise dealers to make arrangements to have sold and unsold units that do not pass inspection repurchased by their FCSD Zone Manager through the normal Reacquired Vehicle (RAV) process.

**New!**

**AFFECTED VEHICLES**

Certain 2004 model year Ford Ranger regular cab pickup trucks built at the Twin Cities Assembly Plant from June 2, 2004 through June 25, 2004. Affected vehicles are identified in OASIS. In addition, for a list of vehicles assigned to your dealership, visit <https://web.fsavinlists.dealerconnection.com>.

**REASON FOR THIS SAFETY RECALL**

In some of the affected vehicles, it may be possible that the frames on short and long wheel base regular cab models have center rail section flanges that were not formed properly. In the event of a collision, an improperly formed center rail section could potentially puncture the fuel tank, resulting in a fuel leak. A fuel leak in the presence of an ignition source could result in a fire.

**SERVICE ACTION**

**DO NOT DRIVE, DEMONSTRATE OR DELIVER** any of the vehicles involved in this recall until they have been inspected per Attachment III. Vehicles that pass the inspection may be released; if a vehicle does not pass inspection, call the Special Service Support Center at 1-800-325-5621.

**New!**

**STOCK VEHICLES**

- Inspect all affected stock vehicles before demonstrating or delivering. *Vehicles which pass inspection may be released.*
- *If a dealer stock unit is found to have an improperly formed frame:*
  - *The vehicle will not be repaired and cannot be sold to customers.*
  - *Contact the Special Service Support Center at 1-800-325-5621 to verify the inspection; a digital photo or Ford on-site inspection may be required after calling.*
  - *When the Special Service Support Center has verified the inspection, contact your Market Area Team and request to have the vehicle uploaded in RAV-Fast.*
  - *Ford Motor Company will repurchase the vehicle utilizing the existing RAV process.*

**New!**

**SOLD VEHICLES**

- Immediately contact any of your affected owners and schedule an inspection date. Inspect other affected vehicles identified in OASIS, which are brought to your dealership.
- Owners of affected vehicles will be notified the week of July 19, 2004 and directed to dealers for inspection.
- *If a customer's vehicle is found to have an improperly formed frame:*
  - *Contact the Special Service Support Center at 1-800-325-5621 to verify the inspection; a digital photo or Ford on-site inspection may be required after calling.*
  - *The vehicle will not be repaired and cannot be returned to the customer.*
  - *Dealers should contact their Service Zone Manager to initiate the process to repurchase the vehicle from the customer.*
  - *The customer should be placed in a rental vehicle until a suitable replacement vehicle can be obtained.*

**OWNER NOTIFICATION MAILING SCHEDULE**

Owners of record will be notified via first-class mail the week of July 19, 2004. Please note that dealers should inspect any affected vehicles that arrive at their dealerships, whether or not the customer has received a letter.

**ATTACHMENTS**

Attachment I:           Administrative Information  
Attachment II:         Labor Allowances and Parts Ordering Information  
Attachment III:        Technical Information  
*Customer Notification Letter*

**QUESTIONS?**

Claims Information: ..... 1-800-423-8851  
Special Service Support Center (Dealer Only) Questions: ..... 1-800-325-5621

Sincerely,

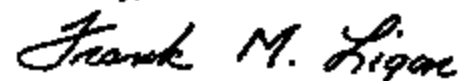

Frank M. Ligon



**DEMONSTRATION / DELIVERY HOLD: Safety Recall 04819-S1**  
Certain 2004 Model Year Ford Ranger Regular Cab Pickups  
Frame Rail Inspection

**OASIS ACTIVATED?** Yes.

**FSA VIN LIST ACTIVATED?** Yes

Available through FMCDealer.com or at <https://web.fsaVINlists.dealerconnection.com>

**New!**

**STOCK VEHICLES**

- Inspect all affected stock vehicles before demonstrating or delivering. *Vehicles which pass inspection may be released.*
- *If a dealer stock unit is found to have an improperly formed frame:*
  - *The vehicle will not be repaired and cannot be sold to customers.*
  - *Contact the Special Service Support Center at 1-800-325-5621 to verify the inspection; a digital photo or Ford on-site inspection may be required after calling.*
  - *When the Special Service Support Center has verified the inspection, contact your Market Area Team and request to have the vehicle uploaded in RAV-Fast.*
  - *Ford Motor Company will repurchase the vehicle utilizing the existing RAV process.*

**New!**

**SOLD VEHICLES**

- Immediately contact any of your affected owners and schedule an inspection date. Inspect other affected vehicles identified in OASIS, which are brought to your dealership.
- Owners of affected vehicles will be notified the week of July 19, 2004 and directed to dealers for inspection.
- *If a customer's vehicle is found to have an improperly formed frame:*
  - *Contact the Special Service Support Center at 1-800-325-5621 to verify the inspection; a digital photo or Ford on-site inspection may be required after calling.*
  - *The vehicle will not be repaired and cannot be returned to the customer.*
  - *Dealers should contact their Service Zone Manager to initiate the process to repurchase the vehicle from the customer.*
  - *The customer should be placed in a rental vehicle until a suitable replacement vehicle can be obtained.*

**TITLE BRANDED / SALVAGED VEHICLES**

Affected title branded and salvaged vehicles are eligible for this recall.

**RELATED DAMAGE**

Related damage claims will not be accepted for this program.

**ADDITIONAL LABOR TIME**

Requests for additional labor time will not be accepted.

**DEMONSTRATION / DELIVERY HOLD: Safety Recall 04S19-S1  
Certain 2004 Model Year Ford Ranger Regular Cab Pickups  
Frame Rail Inspection**

**OWNER REFUNDS**

Refunds are not authorized for this program.

**RENTAL VEHICLES**

Call the Special Service Support Center at 1-800-326-5621 if an affected vehicle, already in customer possession, is found to have an improperly formed frame rail flange. Ford will pay for a rental vehicle until a replacement vehicle can be obtained except for fuel and insurance, which will be at the owner's expense.

**CLAIMS PREPARATION AND SUBMISSION**

- Enter claims using Direct Warranty Entry (DWE).
- Refer to ACESII manual for claims preparation and submission information.

**DEMONSTRATION / DELIVERY HOLD: Safety Recall 04S19-S1**  
Certain 2004 Model Year Ford Ranger Regular Cab Pickups  
Frame Rail Inspection

**TABLE****LABOR ALLOWANCES**

Description	Labor Operation	Labor Time
Inspect Driver Side Frame Rail	04S19A	0.2 Hours
Inspect Drivers Side Frame Rail and call BSSC ( <i>for vehicles that do not pass inspection</i> )	04S19E	0.4 Hours

**PARTS INFORMATION**

Parts are not applicable for this program.

## CERTAIN 2004 MODEL YEAR RANGER VEHICLES — FRAME RAIL INSPECTION

### OVERVIEW

This program involves an inspection of the inboard side of the driver side center and rear frame rails. There are three (3) suspect areas of the frame rail to be inspected. At these areas, the frame rail lower flange lip may not have been formed correctly. See Figure 1.

- At the forward and center area, the frame flange lip should be rolled UP.
- At the rear area, the frame flange lip should be rolled DOWN.

For a vehicle to pass inspection, all flange areas must be properly formed. If any portion of the suspect areas of the frame is formed incompletely or incorrectly, the vehicle should be held, and the Special Service Support Center should be notified by calling 1-800-325-5621.

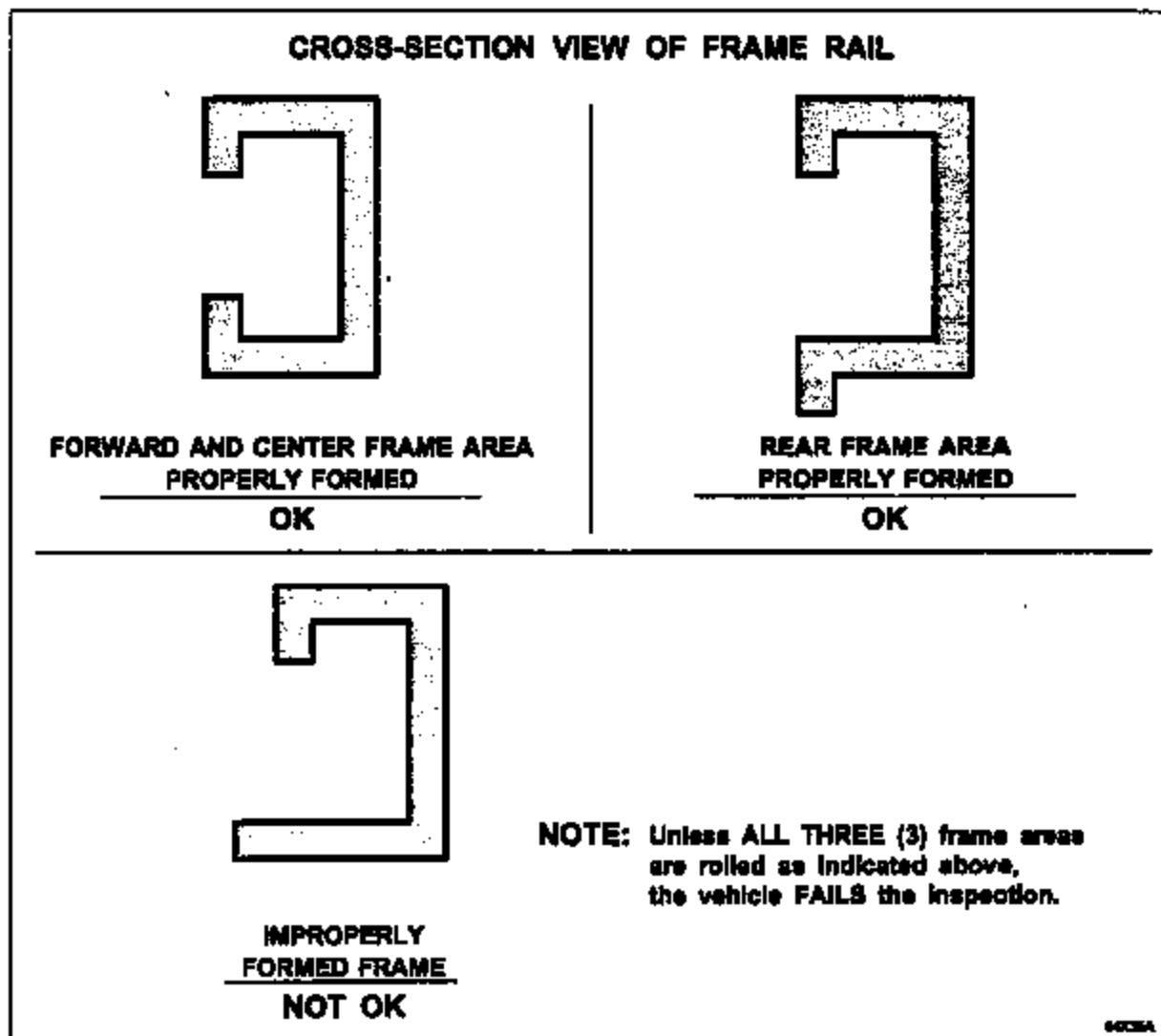

FIGURE 1



## INSPECTION

1. Raise the vehicle on a hoist. Note: Do not place the hoist arms on the driver side frame rail near the fuel tank or your view of the inspection area may be obstructed.
2. Inspect the three (3) suspect areas on the inboard side of the frame rail near the fuel tank. Each area must be rolled along the entire length of the flange. See Figures 2 and 3.
  - If the flange is properly formed, release the vehicle.
  - If the flange is not properly formed, call the Special Service Support Center at 1-800-325-5621 for further instructions.

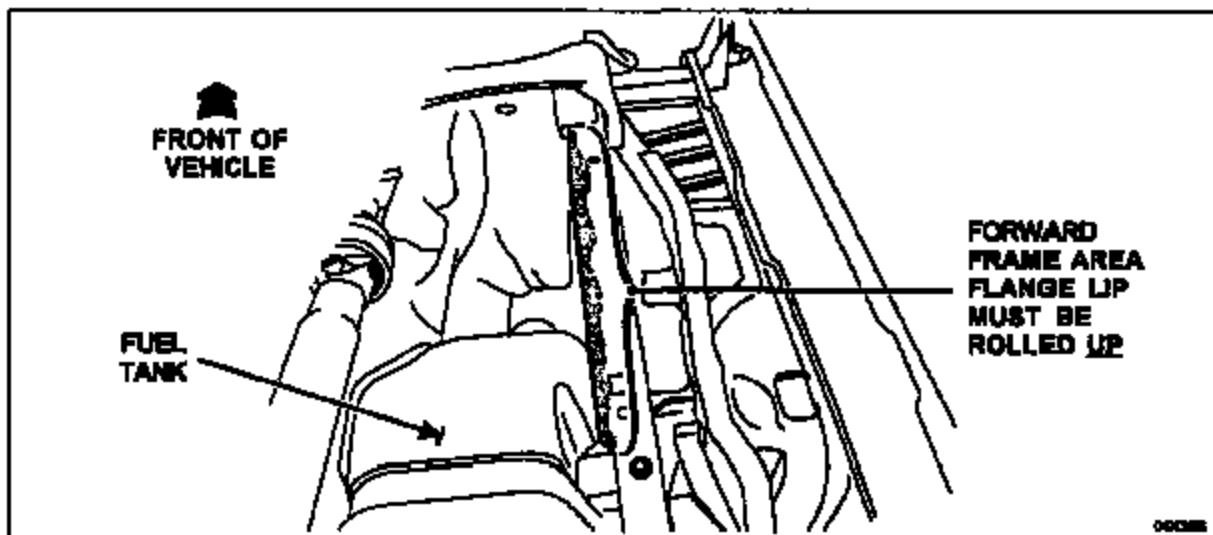

FIGURE 2

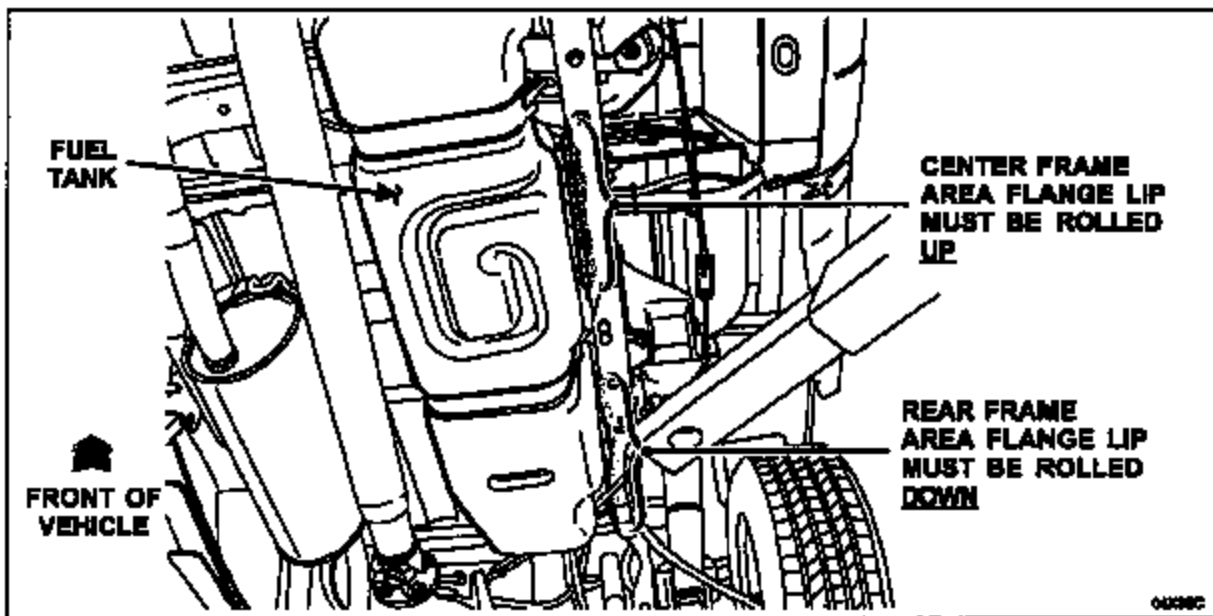
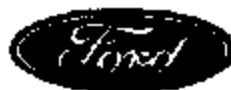

FIGURE 3





Frank M. Ligon  
Ford Motor Company  
P. O. Box 1904  
Dearborn, Michigan 48121

July 2004

Safety Recall 04S19

Mr. John Sample  
123 Main Street  
Anywhere, USA 12345

Your Vehicle Identification Number: 12345678901234567

This notice is sent to you in accordance with the requirements of the National Traffic and Motor Vehicle Safety Act.

Ford Motor Company has decided that a defect which relates to motor vehicle safety exists in certain 2004 Model Year Ford Ranger Regular Cab Pickups.

We apologize for this situation and want to assure you that, with your assistance, we will correct this condition. Our commitment, together with Ford dealers, is to provide you with the highest level of service and support possible.

**What is the issue?** On your vehicle, it may be possible that the frame has center rail section flanges that were not formed properly. In the event of a side impact collision, an improperly formed center rail section could potentially puncture the fuel tank, resulting in a fuel leak. A fuel leak in the presence of an ignition source could result in a fire.

**What will Ford and your dealer do?** Ford Motor Company and your dealer will inspect the frame on your Ranger free of charge, to determine if it was properly manufactured. If the frame is found to be incorrectly manufactured, your vehicle will not be repaired; Ford and your dealer will replace your vehicle. Your dealer will provide a rental vehicle until a suitable replacement vehicle can be obtained. We urge you to return to your dealer for this inspection.

**How long will it take?** The time needed for this inspection is less than one-half day. However, due to service scheduling requirements, your dealer may need your vehicle for a longer period of time.

**What are we asking you to do?**

Please call your dealer without delay and request a service date for Recall 04S19. Provide the dealer with the Vehicle Identification Number (VIN) of your vehicle. The VIN is printed near your name at the beginning of this letter.

**Please note: Federal law requires that any vehicle lessor receiving this recall notice must forward a copy of this notice to the lessee within ten days.**

**Do you need a rental vehicle?**

If your vehicle does not pass the inspection, your dealer is authorized to provide a rental vehicle at no charge (except for fuel and insurance), until a replacement vehicle can be obtained.

**Have you changed your address or sold the vehicle?**

If you have, please fill out the enclosed prepaid postcard and mail it to us so we can update our records. If you have sold the vehicle, the information you provide on the postcard will be used to notify the new owner about this recall.

**Can we assist you further?**

If you have difficulty getting your vehicle inspected promptly and without charge, please contact your dealership's Service Manager for assistance.

If you still have concerns, please contact the Ford Motor Company Customer Relationship Center and one of our representatives will be happy to assist you.

Call 1-800-392-3673. For the hearing impaired call 1-800-232-5952 (TDD).

**Office Hours: (Eastern Time Zone)**

**Monday – Friday: 8AM – 8PM**

**Saturday: 9AM – 5:30PM**

If you wish to contact us through the Internet, our address is:  
[www.ownerconnection.com](http://www.ownerconnection.com)

If you are still having difficulty getting your vehicle inspected in a reasonable time or without charge, you may write the Administrator, National Highway Traffic Safety Administration, 400 Seventh Street S. W., Washington, D. C. 20590 or call the toll free Auto Safety Hotline at 1-888-327-4236 or 1-800-424-9393.

Thank you for your attention to this important matter.

Sincerely,

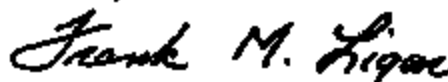

Frank M. Ligon  
Director  
Service Engineering Operations