



RECEIVED

**RECALL CAMPAIGN BULLETIN**

Reference:

NTB04-052

Date:

June 16, 2004

**VOLUNTARY RECALL CAMPAIGN  
POWER SLIDING DOOR LATCH ACTUATOR****CAMPAIGN I.D. # / NHTSA #: RU401 / 04V-186****APPLIED VEHICLE:** 2004 Quest (V42) – SL & SE models ONLY**APPLIED VINS:** Vehicles built between 5N1BV28 U\*4N300000 - 339000**NOTE: Use Service Comm to confirm campaign eligibility.****INTRODUCTION**

Nissan has determined that some 2004 model year Nissan Quest vehicles, SL and SE models only, may have a defect which relates to motor vehicle safety. At an ambient temperature below approximately 40 degrees Fahrenheit, the actuator for the power sliding door(s) may experience binding. If binding occurs and the driver shifts the vehicle out of Park while a power sliding door is still closing, the door latches may not engage. This can result in the door coming open unexpectedly upon rapid acceleration such as accelerating quickly from a stopped position. If a passenger is not wearing a seat belt and the door unexpectedly opens, he could fall out and be injured. Unbelted passengers are at an increased risk of injury in a crash. To prevent this condition from occurring, Nissan is conducting a Voluntary Safety Recall Campaign to replace the actuator for the power sliding door(s).

**IDENTIFICATION NUMBER**

Nissan has assigned identification number RU401 to this campaign. This number must appear on all communications and documentation of any nature dealing with this campaign.

**NUMBER OF VEHICLES POTENTIALLY AFFECTED**

The number of vehicles potentially affected is approximately 26,000.

**DEALER RESPONSIBILITY**

It is the retailer's responsibility to check Service Comm for the campaign status on each vehicle falling within the range of this voluntary safety recall which for any reason enters the service department. This includes vehicles purchased from private parties or presented by transient (tourist) owners and vehicles in a dealer's inventory. **Federal law requires that new vehicles in dealer inventory which are the subject of a safety recall must be corrected prior to sale. Failure to do so can result in civil penalties by the National Highway Traffic Safety Administration.** While federal law applies only to new vehicles, Nissan strongly encourages dealers to correct any used vehicles in their inventory before they are retailed.

## SERVICE PROCEDURE

- **For an Applied SE model:** Replace both the driver and passenger side Power Sliding Door Latch Actuators.
- **For an Applied SL model:** Replace only the passenger side Power Sliding Door Latch Actuator.

### NOTE:

- Look for the "SE" or "SL" model badge on the Rear Hatch of the vehicle.
- The following service procedure shows you how to replace the Latch Actuator on the passenger side Power Sliding Door. This same procedure can be used for the driver side Power Sliding Door.
- Use Service Comm to see if the Sliding Door Squeak and Rattle Repair (B0122) needs to be performed on the vehicle your working on. If so, perform the Squeak and Rattle Repair procedure at the same time you perform the procedure in this bulletin.

### Preliminary Steps

1. Open the passenger side Sliding Door on the "SL" model or both Sliding Doors on the "SE" model. Leave the door(s) open for now.
2. Apply suitable covers to protect carpet, upholstery, paint, etc.
3. Write down all radio station presets.
4. Turn the ignition switch to the OFF position.
5. Disconnect the negative battery cable.

### Parts Removal

6. Remove the Upper Finisher from the Passenger Sliding Door (see Figure 1).
  - Use a Plastic Pry Tool (J-46534\* or equivalent) to release the securing clips (see Figure 1).

\* Essential tool shipped to dealers and to be stored in drawer number 4 of the STSS.

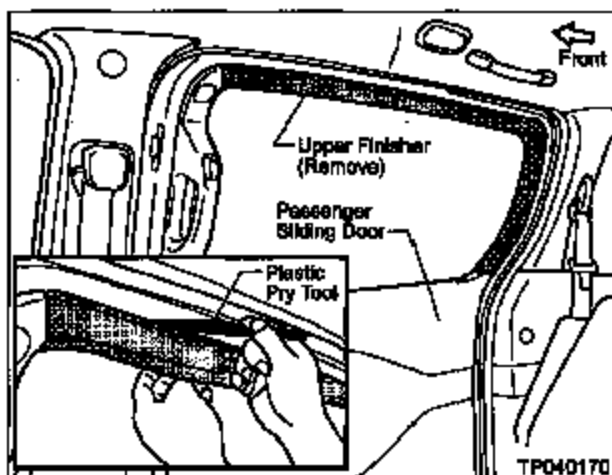

Figure 1

7. Remove the Sliding Door Inner Panel (see Figure 2) as follows:

- Take note of the Clip locations.
- The clip in the upper front corner of the Door Inner Panel is a "Christmas Tree" type clip. Be careful when you remove it. It will need to be re-used.
- The part number for this Clip is 76995-D1000.

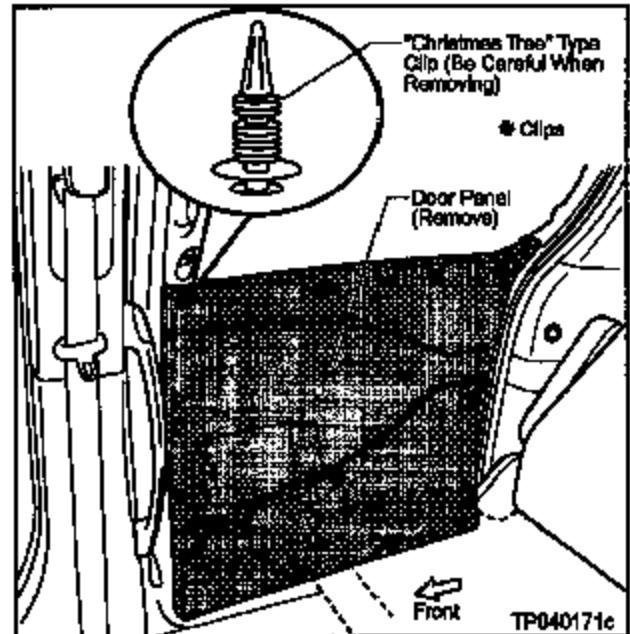

Figure 2

- a. Use a suitable Pry Tool to carefully release the Securing Clips along the front edge of the Inner Door Panel (see Figure 3).

**CAUTION:** Be careful not to damage the paint/plastic. Use duct tape on the end of the Pry Tool (see Figure 3).

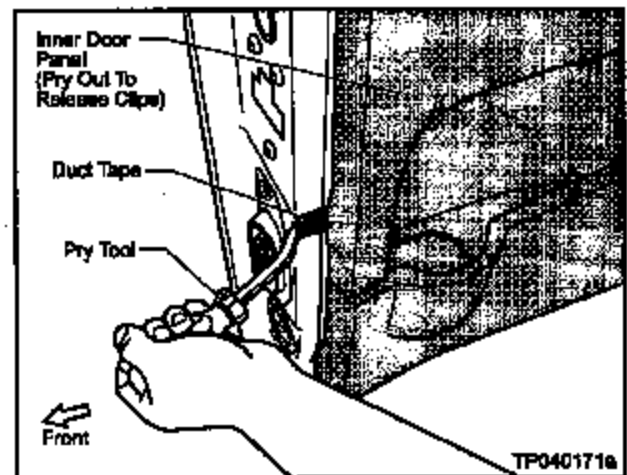

Figure 3

- b. Carefully pull out on the Inner Door Panel to release all remaining securing clips (see Figure 4).
- c. Remove the panel and place it in a clean, safe location.

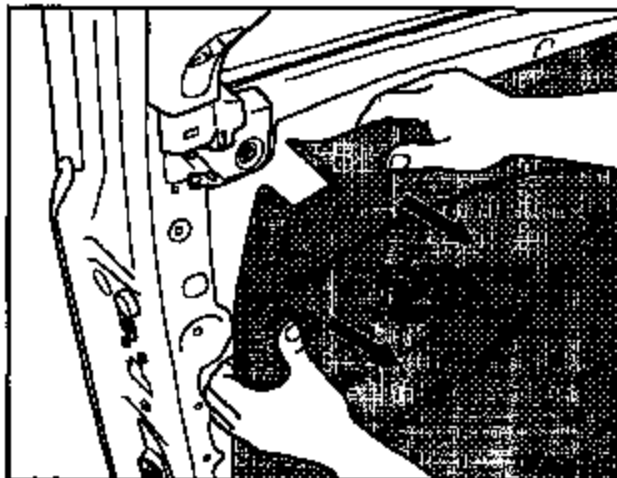

Figure 4

8. Roll the Inner Vapor Barrier/Insulator back (see Figure 5) as follows:
  - You need to do this so you can get to the Sliding Door Latch Assembly.

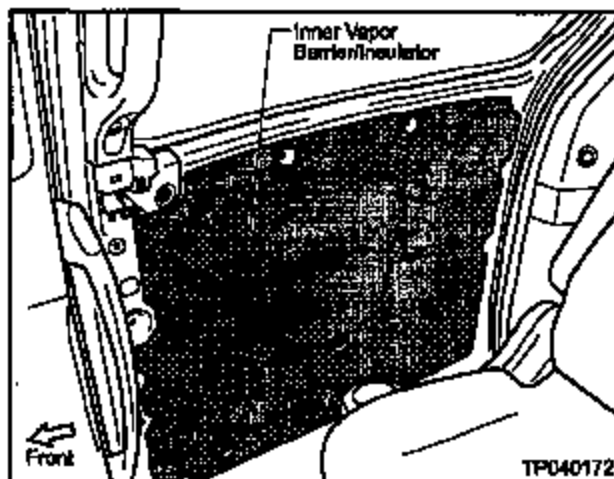

Figure 5

- a. Starting at the front vertical end of the Sliding Door, use a razor knife to carefully cut the adhesive that holds the Vapor Barrier/Insulator to the door (see Figure 6).
- **ONLY** cut the adhesive back to about the middle of the door.

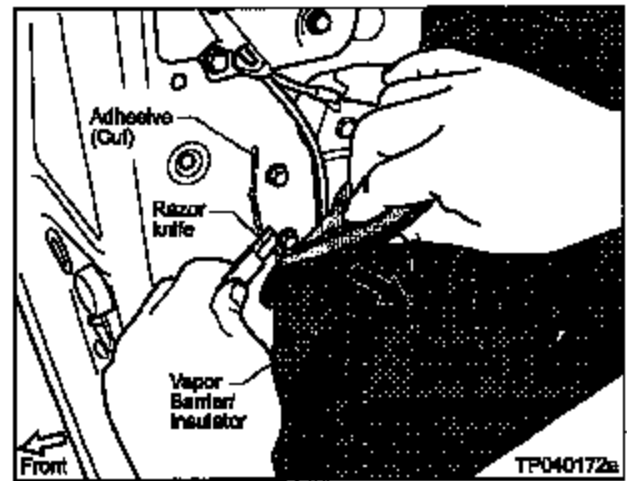

Figure 6

- b. Now, roll the Vapor Barrier/Insulator back and wedge it between the door and the body (see Figure 7). Now you'll be able to get to the Sliding Door Latch Assembly.

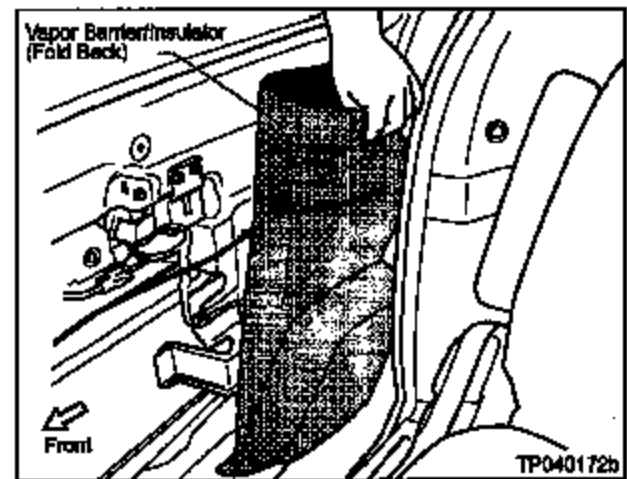

Figure 7

**CAUTION:**

- Before you perform the next step, take note of the Door Lock Actuator Lever position.
  - The Lever must be reinstalled into the Linkage Arm hole properly. If not, the door lock/unlock function will not work.
9. Remove two screws/one bolt and remove the Door Lock Actuator (see Figure 8).
- Carefully let the Actuator hang down by the wire harness.

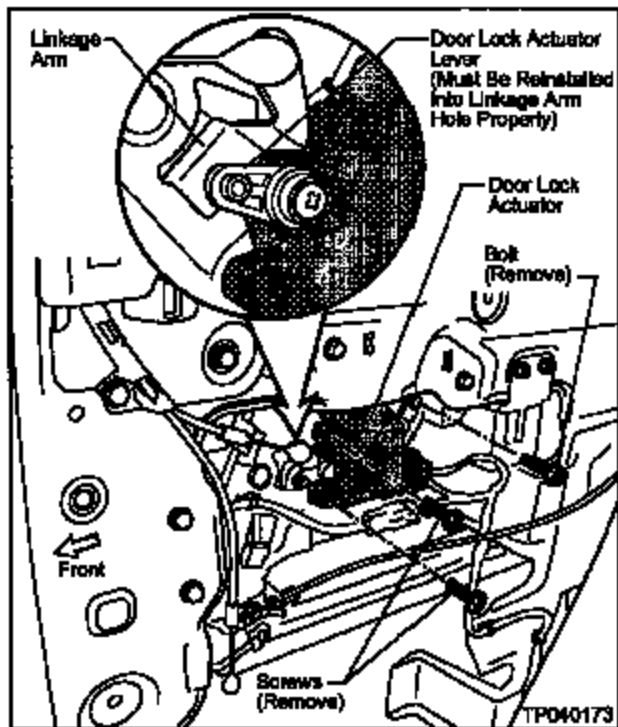

Figure 8

10. Remove the Sliding Door Latch Assembly as follows:

- a. Remove the four Bolts that secure the Latch Assembly to the door (see Figure 9).

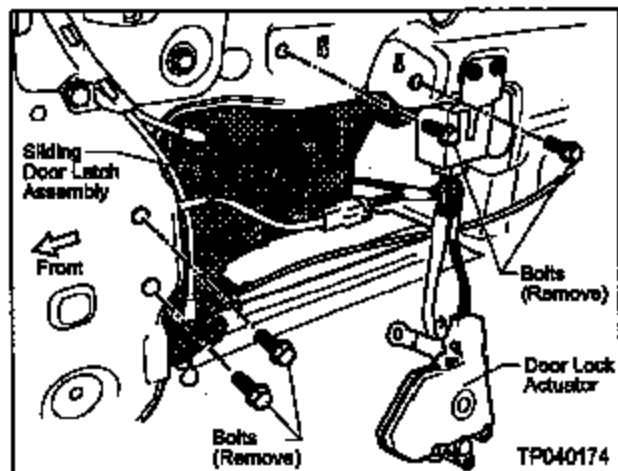

Figure 9

- b. Remove three Torx T30 Screws that secure the front end of the Latch Assembly to the door (see Figure 10).

**NOTE:** You can use an air tool in the "low" setting.

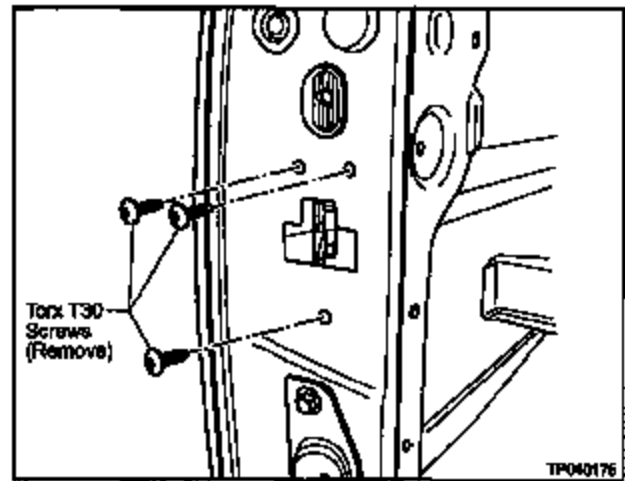

Figure 10

- c. Disconnect the two Cables (shown in Figure 11) from the Latch Assembly.

- Use a pair of Needle-Nose Pliers to release the Cables from the levers (see Figure 11).

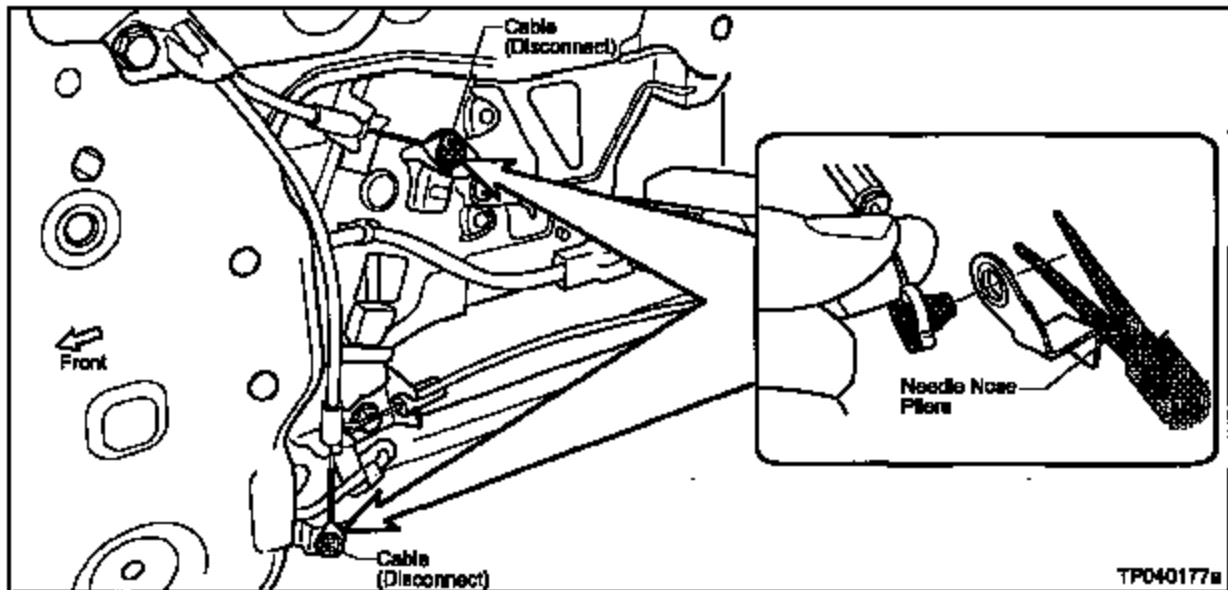

Figure 11

- Pull the Cables out of the Cable Clips (see Figure 12).

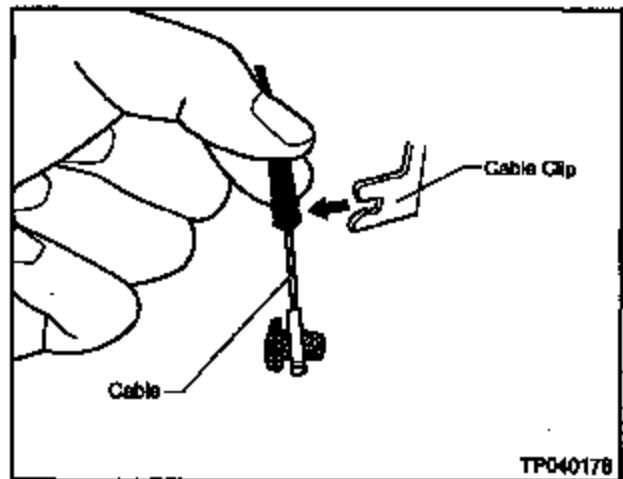

Figure 12

### Replace Door Latch Actuator

11. Reposition the Door Latch Assembly down and out of the door opening (see Figure 13).

- Lift UP on the Latch Assembly to release the support hooks from the door sheet metal.
- One cable is still connected to the Latch Assembly. This is okay. You'll be able to reposition the Latch Assembly enough to replace the Door Latch Actuator (covered in the following steps).

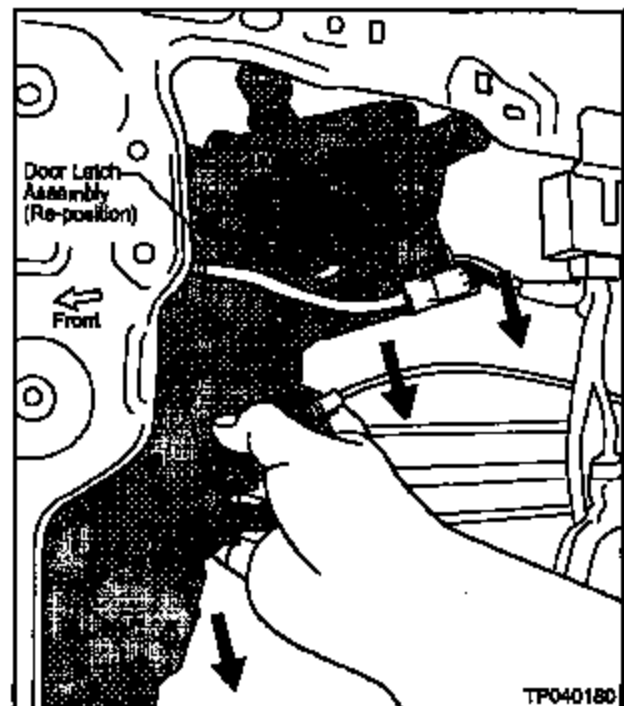

Figure 13



12. Remove the three Screws that secure the Door Latch Actuator to the Latch Assembly (see Figure 14).

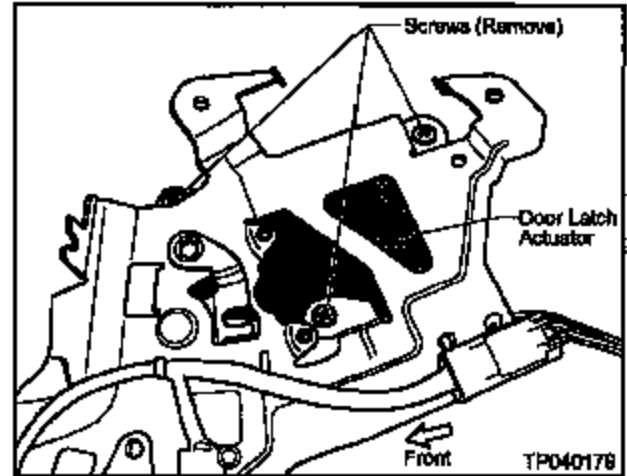

Figure 14

13. Remove the Door Latch Actuator from the Door Latch Assembly (see Figure 15).

- Disconnect the Vehicle Harness from the Door Latch Actuator Harness connector.
- Also, release the Door Latch Actuator Harness Connector from the body of the Latch Assembly (1 clip and 1 alignment pin).
- The driver side Door Latch Actuator has "LH" (or P/N 82553-5Z110) printed on it.
- The passenger side Door Latch Actuator has "RH" (or P/N 82552-5Z110) printed on it.

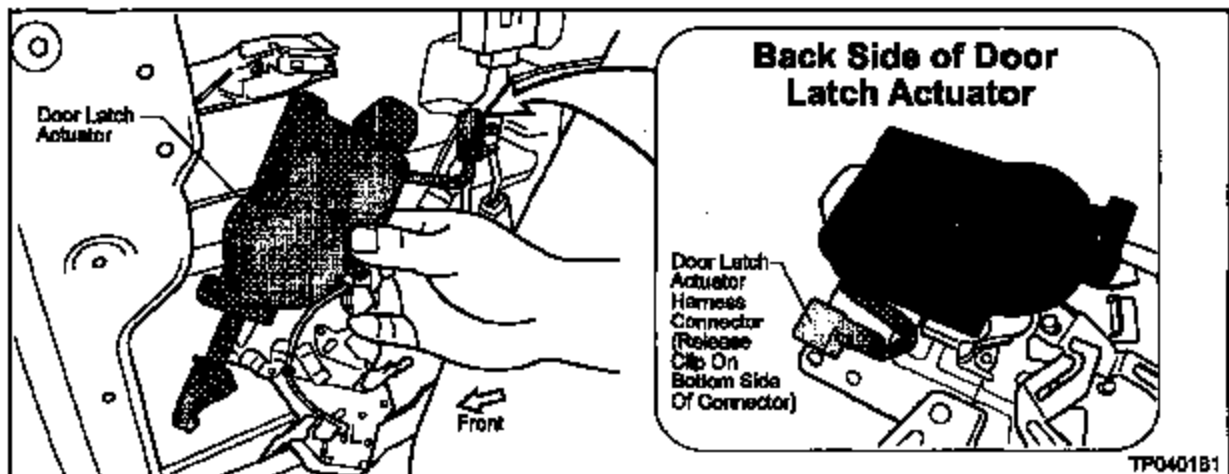

Figure 15

14. Install the new Door Latch Actuator to the Door Latch Assembly using three Screws (see Figure 16).

- Make sure the Latch Actuator "Hook" is properly engaged to the Latch Assembly Lever (see Figure 16).
- Apply grease to the Latch Actuator "Hook" and Latch Assembly Lever as needed.
- Make sure the Door Latch Actuator Harness Connector is correctly routed and securely re-attached to the Latch Assembly (see Figure 16).

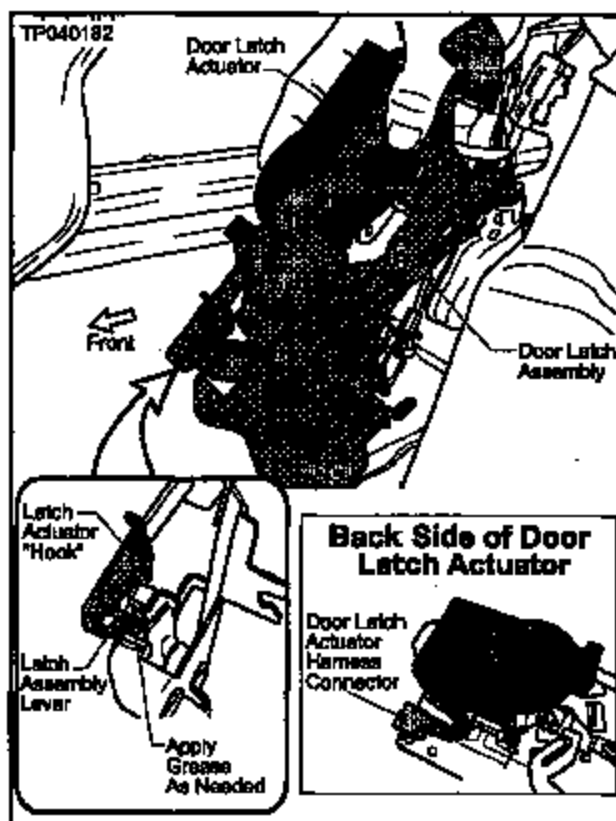

Figure 16

15. Re-Install the Door Latch Assembly (with the new Latch Actuator Installed) as follows:

- a. Position the Door Latch Assembly in the Sliding Door (see Figure 17).

**NOTE:**

- If needed, pull out on the Door Sheet Metal (see Figure 17) to fit the Latch Assembly back into the door.
- Make sure the Child Safety Lever is sticking through the front end of the Sliding Door properly. You may have to remove and re-install the Grommet (around the Child Safety Lever) to do this.

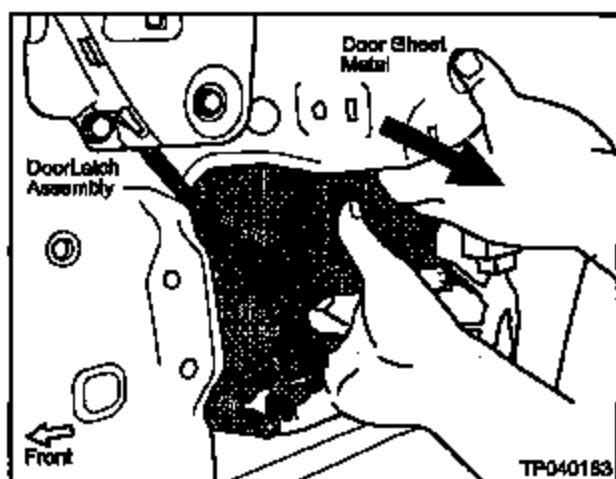

Figure 17

- b. Loosely install the Door Latch Assembly mounting Screws and Bolts.
- Apply medium-strength Thread Locking Fluid (Blue) P/N 999MP-AM005P (or equivalent) to the three Torx Screws (see Figure 18).

**CAUTION: The Screws and Bolts MUST be tightened in order (see next step).**

- c. Tighten the Door Latch Assembly mounting Screws and Bolts as follows:
1. First, make sure the Door Latch Assembly Support Hooks are properly inserted in the door sheet metal (see Figure 18).
  2. Then, tighten the three Torx Screws that hold the Latch Assembly to the front end of the Sliding Door to 5.1 – 6.5 N-m (45 – 57 in-lb). See Figure 18.
- NOTE: Make sure the three Torx Screws are tightened down in their original locations. Look for the original tightening "witness" marks.**
3. Finally, tighten the four remaining Bolts to 5.1 – 6.5 N-m (45 – 57 in-lb). See Figure 18.

- d. Re-Install the Door Lock Actuator onto the Latch Assembly.

**CAUTION: The Door Lock Actuator Lever must be reinstalled into the Linkage Arm hole properly. If not, the door lock/unlock function will not work. Refer to Figure 8.**

- e. Make sure the Vehicle Harness is correctly routed and securely re-connected to the Door Latch Actuator and Latch Assembly. Also, make sure the Cables are properly re-connected (see Figure 19).

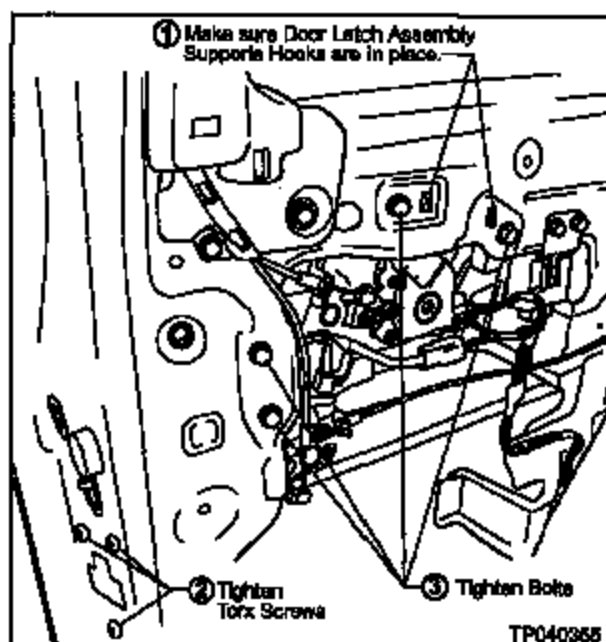

Figure 18

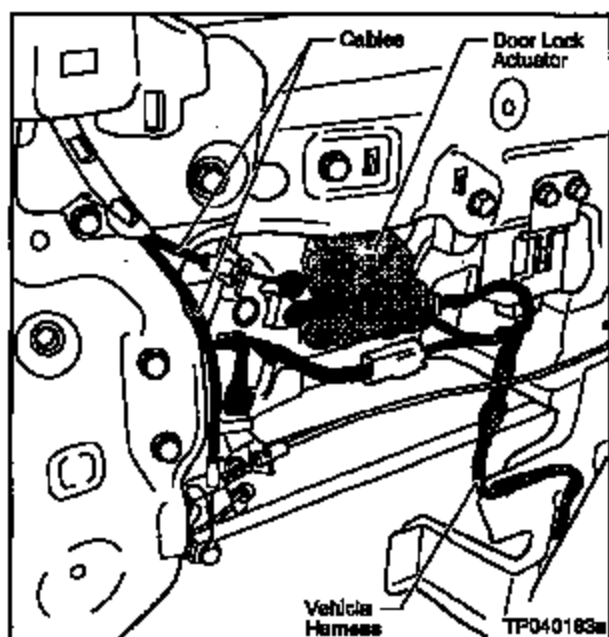

Figure 19

## Check Door Striker/Latch Clearance And Dovetail Clearance

16. Check and adjust the Sliding Door Front Striker/Latch clearance and Dovetail clearance to ensure proper engagement (see Figure 20).

### NOTES:

A) Worn coating on the Striker usually means the Striker/Latch clearance is incorrect.

B) Do NOT perform the above step:

- While the vehicle is on a hoist

OR

- Just after the vehicle was on a hoist

The vehicle must be driven and allowed to "settle" before performing the above step.

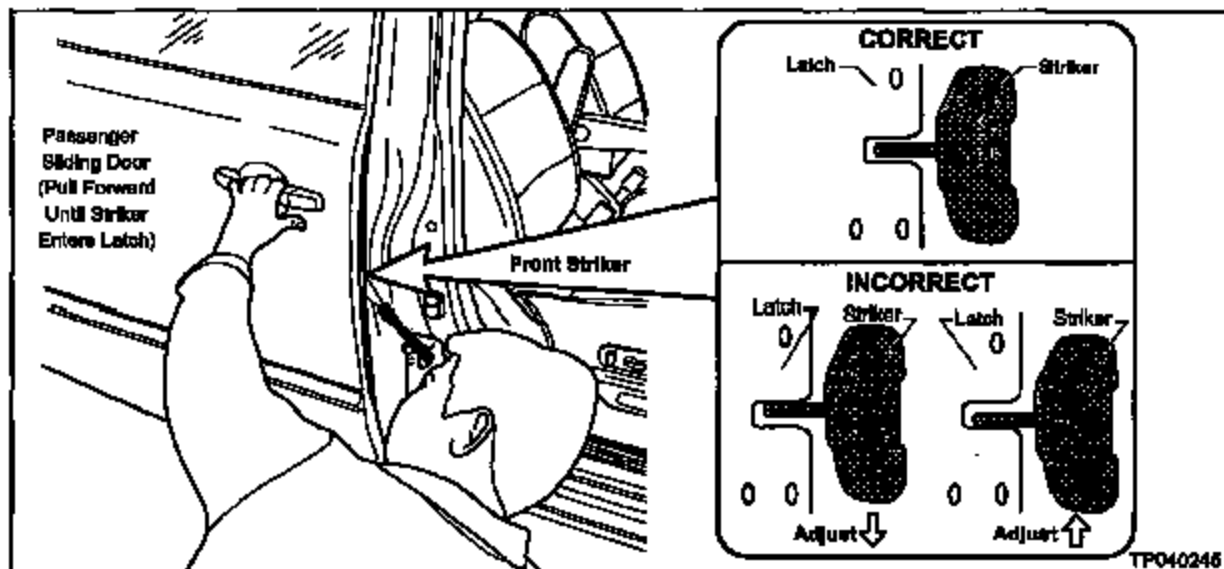

Figure 20 (Front Striker)

## Check Service Comm For B0122 (If you have not already done so)

17. If you have not already done so, use Service Comm to see if the Sliding Door Squeak and Rattle Repair (B0122) needs to be performed on the vehicle your working on. If so, perform the Squeak and Rattle Repair procedure before you perform the following steps.

## Check Door Functions (Before Re-assembly)

18. Confirm all electronic and mechanical door lock, unlock, and release functions operate properly.

## Re-Assemble Other Removed Parts

19. Re-install all previously removed components in the reverse order they were removed.

### **"Re-Initialize" Power Sliding Door (If applicable)**

20. Close the Sliding Doors.
21. Make sure the Power Sliding Door Main Power Switch is OFF (see Figure 21).
22. Reconnect the negative battery cable.
23. Make sure the Child Safety Lever (on the front end of the sliding door) is OFF.

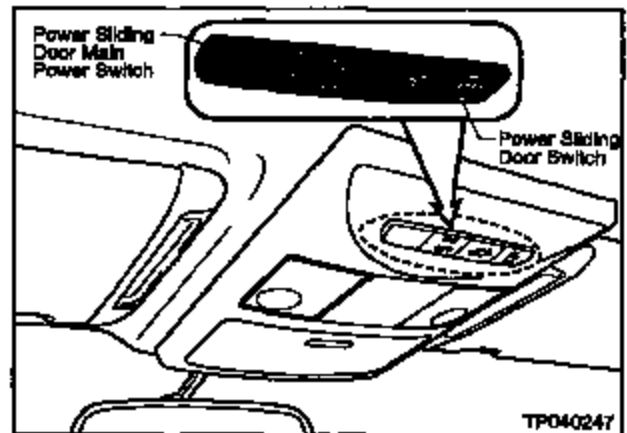

Figure 21

24. Manually open the Sliding Doors to the fully open position.
25. Turn the Power Sliding Door Main Power Switch ON.
26. Press and hold the Power Sliding Door Switch until the door is fully closed and latched. Then release the switch.
27. Press and hold the Power Sliding Door Switch until the door is fully opened. Then release the switch.
28. Press and hold the Power Sliding Door Switch until the door is fully closed and latched.

### **Check Sliding Door Operation**

29. Perform the Sliding Door final check as follows:
  - a. Use the Power Sliding Door Switch (see Figure J36) to make sure the Sliding Door(s) properly:
    - opens
    - closes
    - latches
    - stops and reverses if an obstruction is detected
  - b. Make sure the Child Safety Lever operates properly.
  - c. Confirm proper operation of: all applicable sliding door electrical power switches, exterior door handle, and inside push button/lock knob.

**NOTE:** If the above listed Sliding Door functions do not operate properly, refer to the BL section of the Service Manual for further diagnosis.

## Final Steps

30. Reprogram all radio station presets.

31. Reset the clock.

32. If applicable, reset the Sunroof memory as follows:

- a. Push the Sunroof Tilt Switch in the tilt DOWN position (repeat as necessary) until the Sunroof is fully closed. See Figure 22.
- b. Then, push and hold the Sunroof Tilt Switch (see Figure 22) in the tilt DOWN position for more than 2 seconds.
- c. Reset is complete.

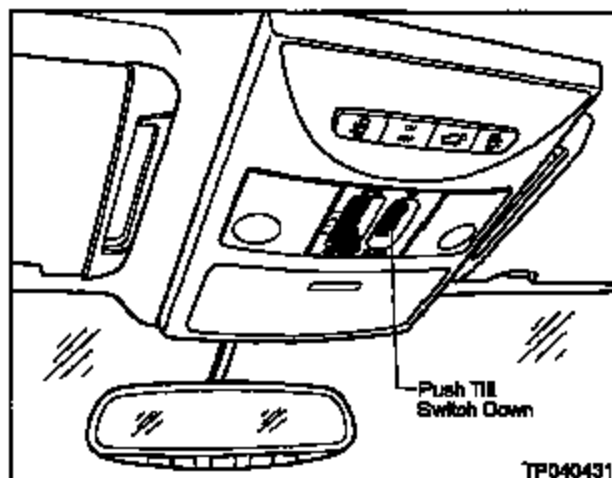

Figure 22

**PARTS INFORMATION**

DESCRIPTION	PART NUMBER	QUANTITY
Latch Actuator (Passenger Side - RH)	82552-5Z110	1
Latch Actuator (Driver Side - LH)	82553-5Z110	1*

\* Only required for the "SE" model.

**CLAIMS INFORMATION**

Campaign I.D.: RU401

If the vehicle has only ONE Power Sliding Door ("SL" model), submit a Campaign ("CM") line claim using the following claims coding information:

DESCRIPTION	OP CODE	FRT
RPL R/H Power Sliding Door Actuator Motor	RU4010	0.4 hrs

**OR**

If the vehicle has TWO Power Sliding Doors ("SE" model), submit a Campaign ("CM") line claim using the following claims coding information:

DESCRIPTION	OP CODE	FRT
RPL R/H & L/H Power Sliding Door Actuator Motors	RU4011	0.7 hrs

## **OWNER'S LETTER**

Dear Nissan Owner:

This notice is sent to you in accordance with the requirements of the National Traffic and Motor Vehicle Safety Act. Nissan has decided that a defect that relates to motor vehicle safety exists in some 2004 model year Nissan Quest vehicles.

### **Reason for Recall**

At an ambient temperature below approximately 40 degrees Fahrenheit, the actuator for the power sliding door(s) may experience binding. If binding occurs and the driver shifts the vehicle out of Park while a power sliding door is still closing, the door latches may not engage. This can result in the door coming open unexpectedly upon rapid acceleration such as accelerating quickly from a stopped position. If a passenger is not wearing a seat belt and the door unexpectedly opens, he could fall out and be injured. Unbelted passengers are at an increased risk of injury in a crash.

### **What Nissan Will Do**

Your Nissan dealer will replace the actuator for the power sliding door(s). This free service should take about one hour to complete, but your Nissan dealer may require your vehicle for a longer period of time based upon their work schedule, or parts availability.

### **What You Should Do**

Contact your Nissan dealer at your earliest convenience in order to arrange an appointment to have your vehicle repaired. **Until your vehicle is repaired, leave the shift lever in the P (Park) position until the power sliding doors are fully closed.** Please bring this notice with you when you keep your service appointment. Instructions have been sent to your Nissan dealer. If the dealer fails, or is unable to make the necessary repairs free of charge, you may contact the National Consumer Affairs Office, Nissan North America, Inc. at P.O. Box 191, Gardena, California 90248-0191. The toll free number is 1-800-753-9781. You may also contact the Administrator of the National Highway Traffic Safety Administration, 400 Seventh Street SW, Washington, D.C. 20590 or call the toll free Safety Hotline at (888) 327-4236.

Federal law requires that any vehicle lessor receiving this recall notice must forward a copy of this notice to the lessee within ten days.

Thank you for your cooperation. We are indeed sorry for any inconvenience this may cause you.