

NISSAN

NISSAN NORTH AMERICA, INC.

Corporate Office
18501 South Figueroa St.
Gardena, California 90248-4500
Mailing Address: P.O. Box 191
Gardena, California 90248-0191
Telephone: 310.532.3111

December 3, 2004

04V-103

Mr. George Person
Chief, Recall Analysis Division
Office of Defects Investigation
Safety Assurance
National Highway Traffic Safety Administration
400 Seventh Street, S.W.
Washington, D.C. 20590

Ref: 04V-103

Dear Mr. Person:

The enclosed communication is being provided pursuant to 49 CFR Part 573.6(c)(9).

Technical Compliance Department

Encl.

To: ALL NISSAN DEALER PRINCIPALS, SERVICE MANAGERS, AND PARTS MANAGERS

Subject: 2004 Quest Front Passenger Seat Occupant Detection System Recall Campaign

***** Update to earlier Nissan Net messages *****

The purpose of this Nissan Net message is to inform Nissan dealers of a revised bulletin for this campaign, a revised Seat Inspection Form (SIF) and the re-notification of Quest owners who have not yet had their seat re-calibrated. See below for additional details.

***** Recall Campaign Bulletin *****

Recall Campaign Bulletin NTB04-051 has been revised to include a Procedure Index of the required service procedures related to this campaign from initial customer contact through delivery of the vehicle (with re-calibrated seat) back to the customer. Several procedures including headrest removal, seat packaging/shipping and seat re-installation have been revised to provide additional clarity when performing this campaign repair.

The revised bulletin (NTB04-051a) is now available on ASIST and also on NNAnet.com under My Documents in the Parts/Campaign and Service/Campaign categories. Please discard any copies of the original bulletin.

***** Seat Inspection Form *****

Twenty five (25) sets of revised Seat Inspection Forms are being sent to your dealership. The form has been revised as a 3-part form to eliminate the need to copy the form. Upon completion of the seat inspection, the first copy is to be kept with the Repair Order (R.O.), the second is to be attached to the seat that is being recalibrated and the third copy is for the customer to retain.

Additional copies of the Seat Inspection Form can be obtained (in packets of 25) by contacting Nissan Publications at 1-800-247-5321 and requesting Form ID: Quest SIF. The Seat Inspection Form (one part) will continue to be available on NNAnet.com under My Documents in both the Parts/Campaign and Service/Campaign categories.

***** Customer Notification *****

Nissan is re-notifying approximately 7,800 Quest customers who have not yet had their front passenger seats recalibrated. To support this activity, a limited number of additional seat packaging crates will become available. If an additional crate is needed, please contact your Nissan Dealer Parts and Service Manager (DPSM).

Nissan Parts and Service Operations
11/03/2004



RECALL CAMPAIGN BULLETIN

Reference:

NTB04-051a

Date:

November 3, 2004

VOLUNTARY RECALL CAMPAIGN PASSENGER FRONT SEAT SRS OCCUPANT DETECTION SYSTEM

IMPORTANT: THIS BULLETIN HAS BEEN REVISED.

- Procedure Index was added. Head restraint removal, seat inspection, seat packaging/shipping, and seat re-installation procedures were clarified.
 - Use this bulletin NTB04-051a ONLY.
 - Discard all copies of NTB04-051.

CAMPAIGN I.D. # / NHTSA #: B0112 / 04V-103

APPLIED VEHICLE: 2004 Quest (V42)

APPLIED VINS: Vehicles built between: 5N1BV28U*4N300000 - 315562

NOTE: Use Service Comm to confirm campaign eligibility.

INTRODUCTION

Nissan has determined that the front passenger seat on some 2004 model year Nissan Quest vehicles fail to comply with Federal Motor Vehicle Safety Standard 208 – Occupant Crash Protection. In order to meet one part of Safety Standard 208, the air bag for the front passenger seat must be turned off (so that it does not inflate) when certain occupants, such as small children, are in the front seat. This prevents such occupants from being injured by an inflating air bag in a collision.

To do this, the front seat has an Occupant Detection System (ODS). The ODS measures the pressure on the seat when it is being used and turns the air bag on or off as required by the regulation. One test under the regulation is to place a dummy about the size of an average six-year old child on the passenger seat and make sure the air bag turns off. Nissan has found that the ODS may not work properly in this test. To correct this condition, Nissan is conducting a Voluntary Safety Recall Campaign to remove the front passenger seat and ship it in a special container to a facility which will modify the Occupant Detection System and then return the seat to the dealer. When the passenger seat is removed, the vehicle can not be operated by the customer.

IDENTIFICATION NUMBER

Nissan has assigned identification number B0112 to this campaign. This number must appear on all communications and documentation of any nature dealing with this campaign.

NUMBER OF VEHICLES POTENTIALLY AFFECTED

The number of vehicles potentially affected is approximately 13,700.

DEALER RESPONSIBILITY

It is the retailer's responsibility to check Service Comm for the campaign status on each vehicle falling within the range of this voluntary safety recall which for any reason enters the service department. This includes vehicles purchased from private parties or presented by transient (tourist) owners and vehicles in a dealer's inventory. **Federal law requires that new vehicles in dealer inventory which are the subject of a safety recall must be corrected prior to sale. Failure to do so can result in civil penalties by the National Highway Traffic Safety Administration.** While federal law applies only to new vehicles, Nissan strongly encourages dealers to correct any used vehicles in their inventory before they are retailed.

PROCEDURE INDEX

The following is an index of the required procedures related to this campaign repair. It starts with initial (first) customer contact and ends with delivery of the vehicle (with re-calibrated seat) back to the customer.

Service Advisor	Page
• Initial (First) Customer Contact	3
▶ Confirm availability of Seat Packaging Crate.	
▶ Schedule customer appointment (early in the week).	
▶ Schedule alternate transportation, as needed.	
• Scheduled Appointment Date	4
▶ Confirm alternate transportation for the customer.	
▶ Inspect seat and complete the Seat Inspection Form.	
Service Department	
• Obtain Seat Packaging Crate <u>Base</u>	6
• Inspect Seat (in vehicle)	6
• Remove Seat	7
• Remove Head Restraint	11
Parts/Shipping Department	
• Install Plastic Cover On Seat	11
• Package/Ship Seat	12
▶ FedEx Shipping Procedure	
▶ DDS Shipping Procedure	
• Inspect Seat After it Returns From Re-Calibration	21
Service Department	
• Re-Install Seat and Head Restraint	22
• Check/Clear Any Stored DTC(s)	22
• Check Air Bag Module Warning Light	23
• Check Occupant detection System (ODS)	23
• Check Seat/Components Operation	24
• "Re-Initialize" Power Sliding Door (if applicable)	24
• Check Sliding Door Operation	26
• Final Steps	26

SPECIAL CUSTOMER ASSISTANCE FEATURES

Nissan recognizes that the re-calibration of the seat installed in a customer owned or leased vehicle requires special customer handling. Nissan has identified the following times the customer may contact your dealership:

- When the customer first learns of the campaign either through receipt of an Owner Notification Letter from Nissan, through the Nissan-USA.com web site or other internet source or on a routine service visit to your dealership.
- When the customer brings their vehicle at the scheduled appointment time to have the front passenger seat re-calibrated.
- When the customer picks up their vehicle after the campaign repair has been completed on the vehicle.

To ensure the highest levels of customer satisfaction, Nissan recommends the following actions be taken:

Initial (First) Customer Contact

- Respond to any customer questions. Refer to the Owner's Letter (page 30).
- Inform the customer that the re-calibration: (1) requires removal of the front passenger seat from the vehicle, (2) the re-calibration will take about a week to complete and (3) alternate transportation is available free of charge to the customer during this period of time. However, the rental vehicle may not be a van.
- If the passenger seat has been changed from its original factory specifications (such as replacement of the original seat material), inform the customer that the seat must be returned to the original factory condition to be eligible for the campaign repair. Any aftermarket accessories such as seat covers or video screens installed in the rear of the head restraint must be removed before the seat is shipped to the repair facility.
- Inform the customer that an appointment is necessary. Prior to scheduling the appointment confirm the availability of a Seat Packaging Crate.
- Schedule the appointment. Nissan recommends an appointment early in the week (Mon/Tue/Wed) so the vehicle can be returned to the customer within the same week. Car rental is pre-approved for 5 days. If car rental is required for more than 5 days, pre-approval must be obtained from the Warranty Claim Call Center.
- You may advise owners that prior to the scheduled appointment the vehicle is safe to drive and that the front passenger airbag light is an accurate indicator of the status of the front passenger seat airbag. At the same time, it is important to inform the customer that Nissan recommends children 12 years old and under be properly restrained in the REAR SEAT. You may also refer concerned callers to Section 1 of their Owner's Manual for additional information about proper use of seats, seat belts, child restraints, and airbags.

- Schedule alternate transportation for the customer as needed. NNA has named Enterprise as the preferred source for providing alternate transportation to Nissan Quest customers during the 2004 Quest Front Passenger Seat Occupancy Detection System Campaign. This special program is effective through June 30, 2005. This is not an exclusive agreement and, subject to the Claims Information section of this bulletin, your dealership may elect to utilize other sources to provide alternate transportation to your Nissan Quest customers.

NOTE: When reserving a car rental through Enterprise, please dial 1-877-722-0097. See page 27 for additional information regarding Enterprise car rental.

Scheduled Appointment Date

- If applicable, confirm availability of alternate transportation prior to customer arrival.
- Complete the Seat Inspection Form (Figure 1) and have the customer sign the form. If this is a drop-off, please note any damage, marks, etc. and sign the form. In some cases, a digital photo may be appropriate.
- Confirm the customer has removed all personal items from the seat (for example, check the storage pocket on the rear of the seat back). Removal of all personal items from the vehicle is encouraged.
- Provide a copy of the Seat Inspection Form to the customer, keep a copy with the Repair Order, and attach a copy to the lower seat frame of the front passenger seat using a tie-wrap and a Nissan Parts Return Bag (or equivalent Zip-Loc bag with grommet). See Figure 2.

Re-Calibration Complete

- Contact the customer to arrange for return of alternate transportation and pick-up of the vehicle.
- Upon customer arrival, complete the second section of Seat Inspection Form and have the customer sign the form acknowledging receipt.
- Address any customer questions or concerns.

Seat Inspection Form

TP040698a

Seat Condition Before Removal From Vehicle

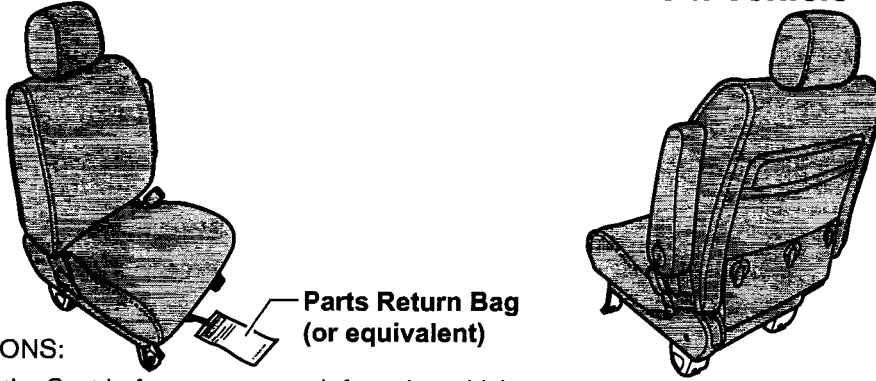

INSTRUCTIONS:

- 1) Inspect the Seat before you remove it from the vehicle.
- 2) Indicate the location of any existing damage using (A), (B), (C), or (D).
- 3) Review the inspection results with the customer.
- 4) Have the customer and the qualified dealer personnel sign (below).
- 5) Write down the Vehicle Ident. No. (VIN), Dealer Code, FedEx Airbill No. or DDS carrier name.
- 6) Keep a copy of this Form with the R.O., then insert a copy in a Parts Return Bag (or equiv.) and attach the bag to the Pass. Front Seat Lower frame (see above). Give a copy to the customer.

(A) Scratches (B) Torn Covering (C) Mark or Stain (D) Other _____

Notes: _____

VIN (last six digits) _____ Dealer Code _____ FedEx Airbill No. or DDS carrier name _____

Dealer Signature

Owner Signature

Seat Condition After Re-Calibration

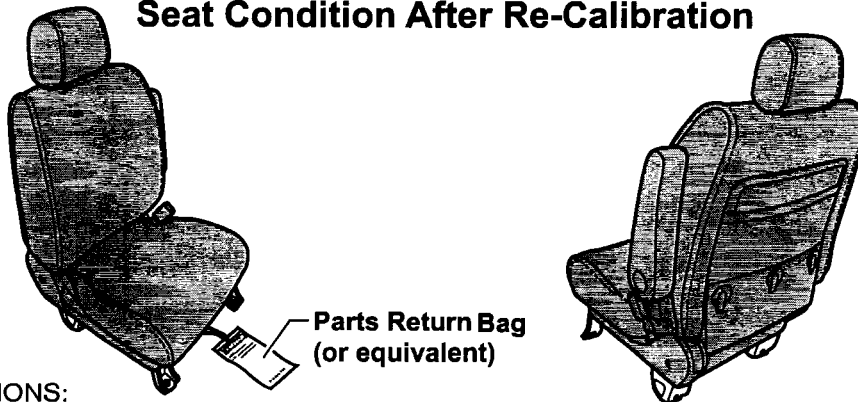

INSTRUCTIONS:

- 1) Inspect the seat after it returns from being re-calibrated.
- 2) Indicate the location of any new damage using (A), (B), (C), or (D).
- 3) Make sure any new damage is repaired, then submit a normal warranty claim.
- 4) Review the inspection results with the customer.
- 5) Have the customer and the qualified dealer personnel sign (below).
- 6) Keep a copy of this form with the R.O. and give a copy to the customer.

(A) Scratches (B) Torn Covering (C) Mark or Stain (D) Other _____

Notes: _____

Dealer Signature

Owner Signature

Copy 1: Retain with R.O. Copy 2: Attach to seat Copy 3: Customer copy

Resolve Form ID: Quest SIF

Figure 1

SERVICE PROCEDURE

This service procedure involves removal of the Front Passenger Seat and preparing it for shipment to a Nissan facility to have the SRS Occupant Detection System re-calibrated.

Obtain Seat Packaging Crate Base

1. Obtain a seat packaging crate base (for sending seat to re-calibration facility) from the Parts/Shipping department.

Inspect Seat (in vehicle)

2. Confirm the seat was inspected for any existing damage before you remove it from the vehicle.
 - Make sure the Seat Inspection Form (Figure 1) is attached to the lower seat frame (see Figure 2 below). Also, confirm that one copy of the Seat Inspection Form is attached to the Repair Order and kept with the vehicle.

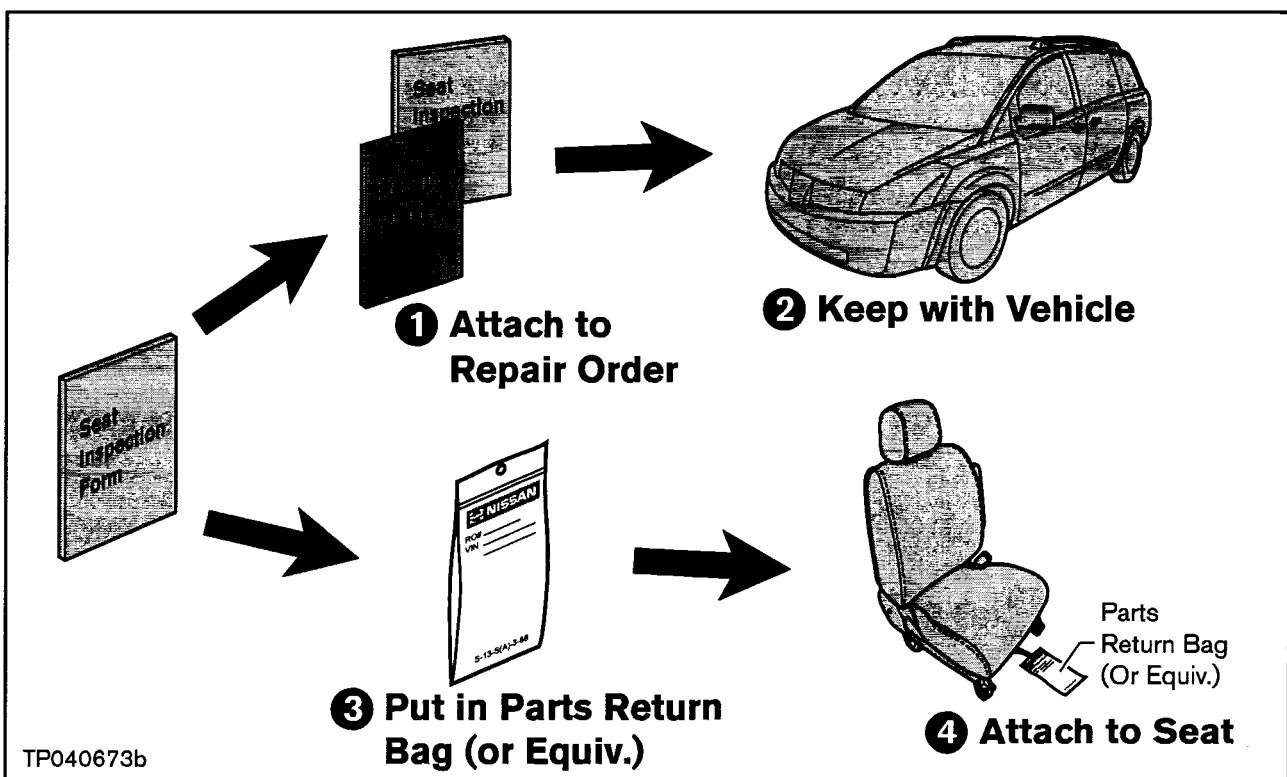

Figure 2

- If a Seat Inspection Form has NOT been completed, obtain one NOW (from the Shipping Information Packet). Then complete the form, making sure the following information is included on the form:
 - ▶ Any existing damage
 - ▶ Last six digits of the Vehicle Identification Number (VIN)
 - ▶ Dealer Code
 - ▶ FedEx Airbill number or DDS carrier name

NOTE: If the FedEx Airbill number or DDS carrier name is not known at this time, this information can be added later in the process.

 - ▶ The customer (if available) and a qualified dealer person (Service Advisor and/or Service Technician) have reviewed and signed the form.

Remove Seat

CAUTION: In addition to the plastic cover for the seat, use suitable covers to protect other upholstery, carpet, paint, etc. when performing this service procedure.

IMPORTANT: Make sure you follow the below step carefully. If the seat is not positioned properly, the seat may not fit in the shipping crate.

3. Position the seat so that:

- The Seat Back is leaning forward (towards the front of the vehicle - about 70°). See Figure 3.
- The seat is in the middle of its forward and rearward travel.

4. Write down all radio station presets.

5. Make sure the ignition switch is **OFF**.

6. Disconnect both battery cables and wait for at least 3 minutes.

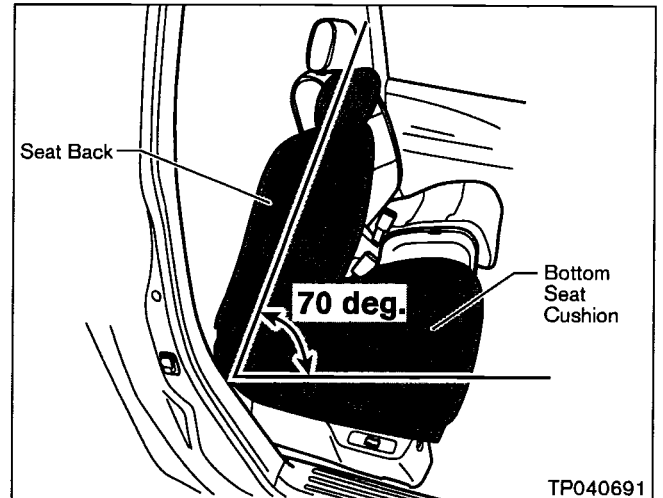

Figure 3

7. Remove the Passenger Seat RH "Skirt" Finisher as follows:

a. Use a Torx T25 to remove the Screw at the front end of the Finisher (see Figure 4).

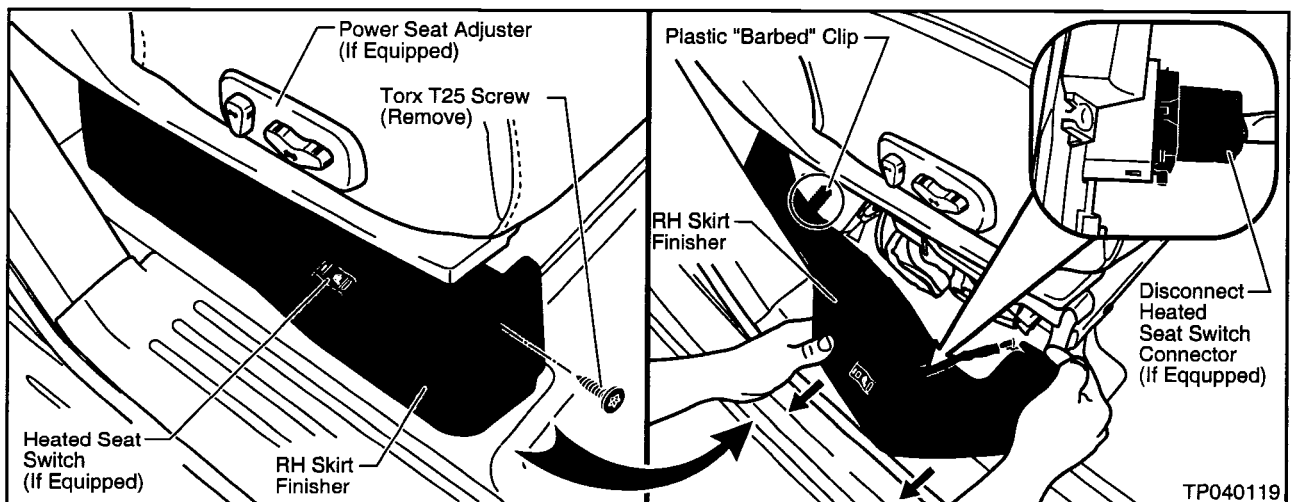

Figure 4

b. Carefully pull out (towards the outside of the vehicle) on the Finisher to release any securing clips (see Figure 4).

c. If equipped, disconnect the Heated Seat Switch Harness Connector (see Figure 4).

d. Keep the RH Skirt Finisher and the Torx T25 Screw in the vehicle while the seat is sent out for re-calibration.

8. Remove the Passenger Seat LH Skirt Finisher as follows:

a. Use a Torx T25 to remove the Screw at the front end of the Finisher (see Figure 5).

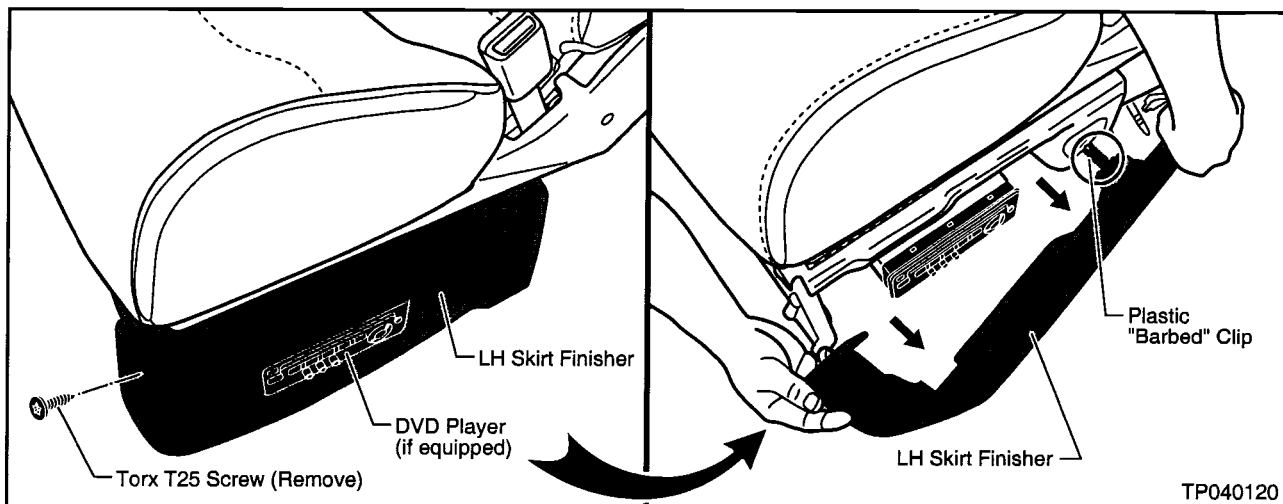

Figure 5

b. Carefully pull out (towards the inside of the vehicle) on the Finisher to release any securing clips (see Figure 5).

c. Keep the LH Skirt Finisher and the Torx T25 Screw in the vehicle while the seat is sent out for re-calibration.

9. Remove the two Mounting Bolts that secure the front of the seat frame (see Figure 6).

10. Keep the Mounting Bolts in the vehicle while the seat is sent out for re-calibration.

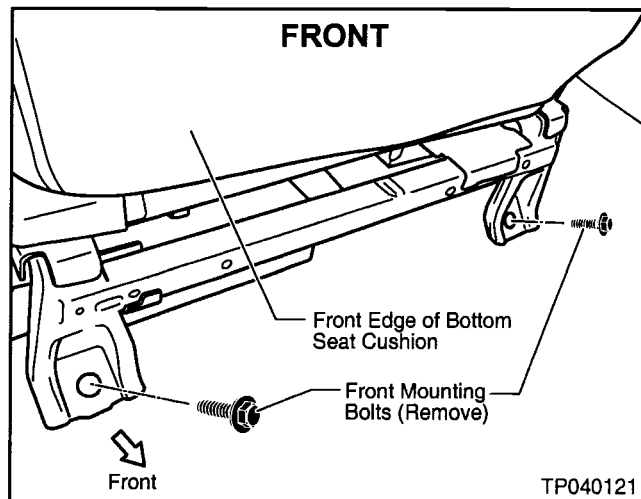

Figure 6

11. Remove the two Mounting Bolts that secure the rear of the seat frame as follows:

- a. To reach the Mounting Bolts, carefully fold the Carpet Cover back towards the rear of the vehicle (see Figure 7).
- b. After removing the Bolts, keep them in the vehicle while the seat is sent out for re-calibration.

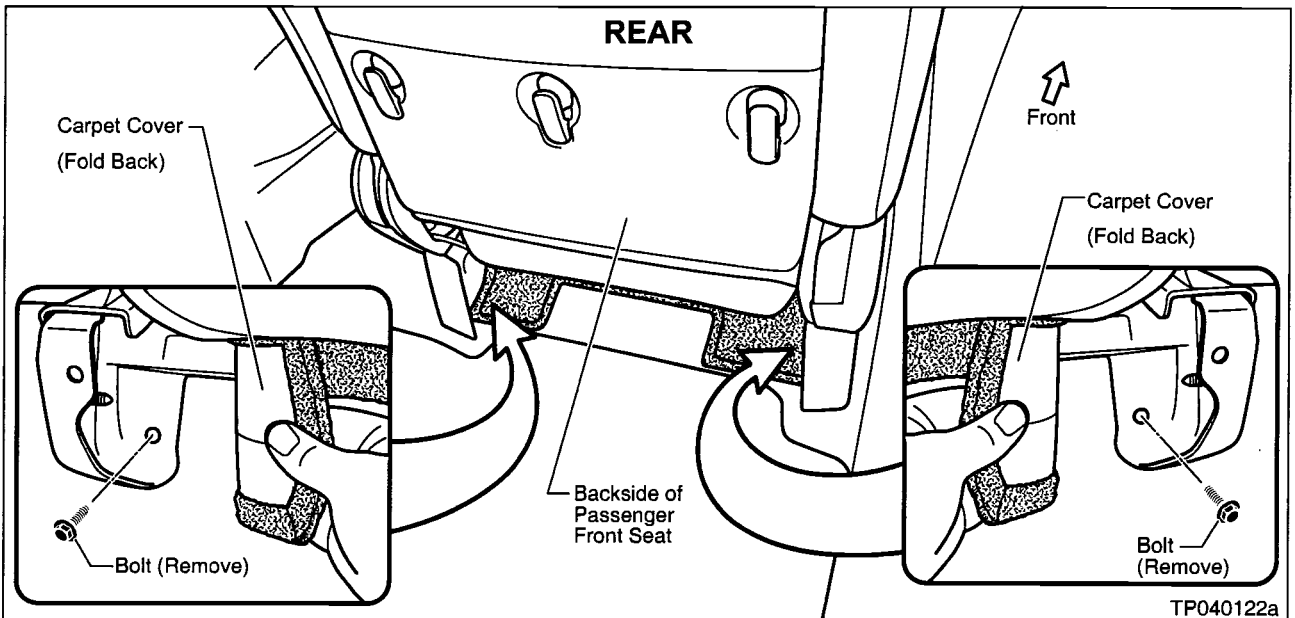

Figure 7

12. Carefully disconnect the following harness connectors from the Passenger Front Seat (see Figure 8).

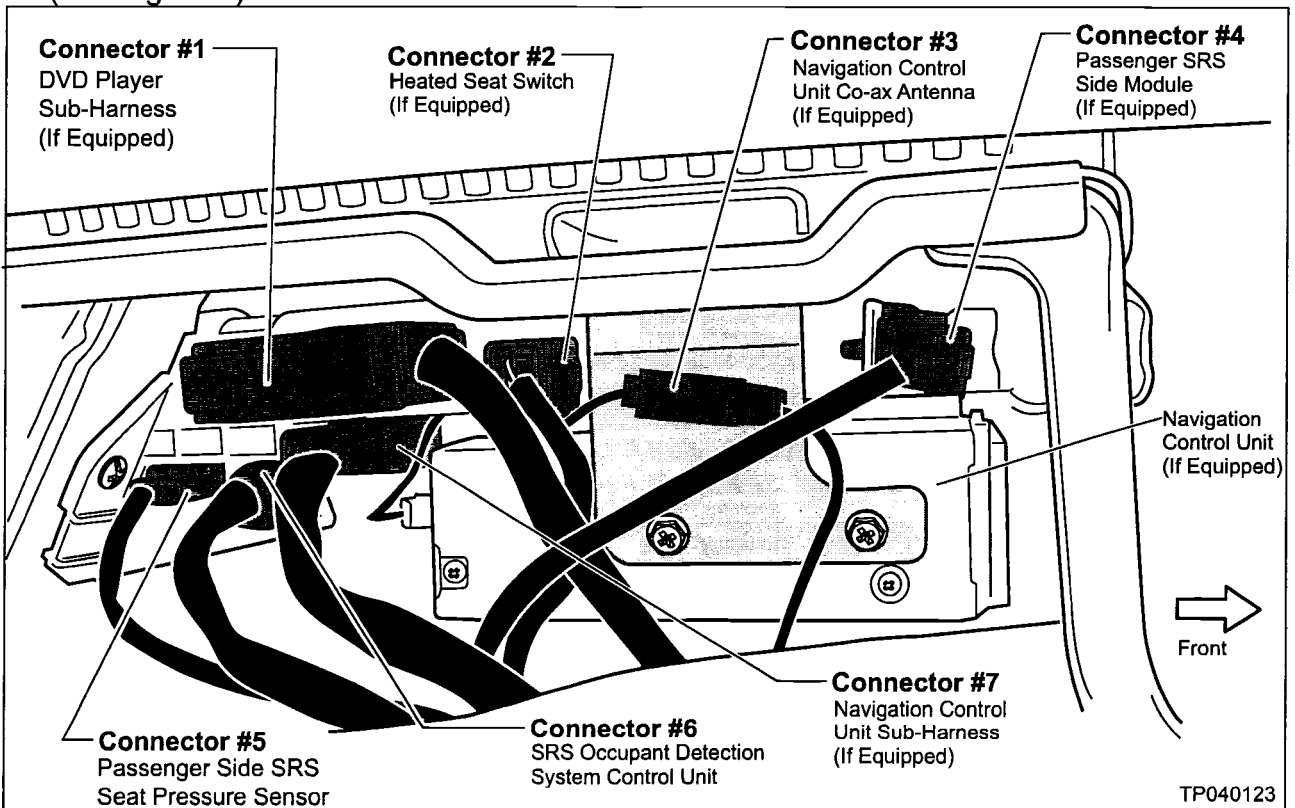

Figure 8

13. Carefully remove the seat from the vehicle.

Install Seat Onto Seat Packaging Crate Base

14. Install the seat onto the provided Seat Packaging Crate Base as follows:

- a. Place the seat on the crate base, paying strict attention to the CAUTIONS below.

CAUTION:

- Make sure the seat faces the front end of the Seat Packaging Crate Base.
 - ▶ The front end of the **Corrugated/Plywood Base** is painted with a color.
 - ▶ The front end of the **All-Plywood Base** has "FRONT" painted on it.
- When setting the seat onto the Base, make sure you place the rear end of the seat frame onto the Base first, then lower the front end of the seat down into position (see Figure 9).
 - ▶ This will help prevent damage to the components (Navigation Control Unit, DVD Player, etc. - if equipped) that are mounted to the underside of the seat.

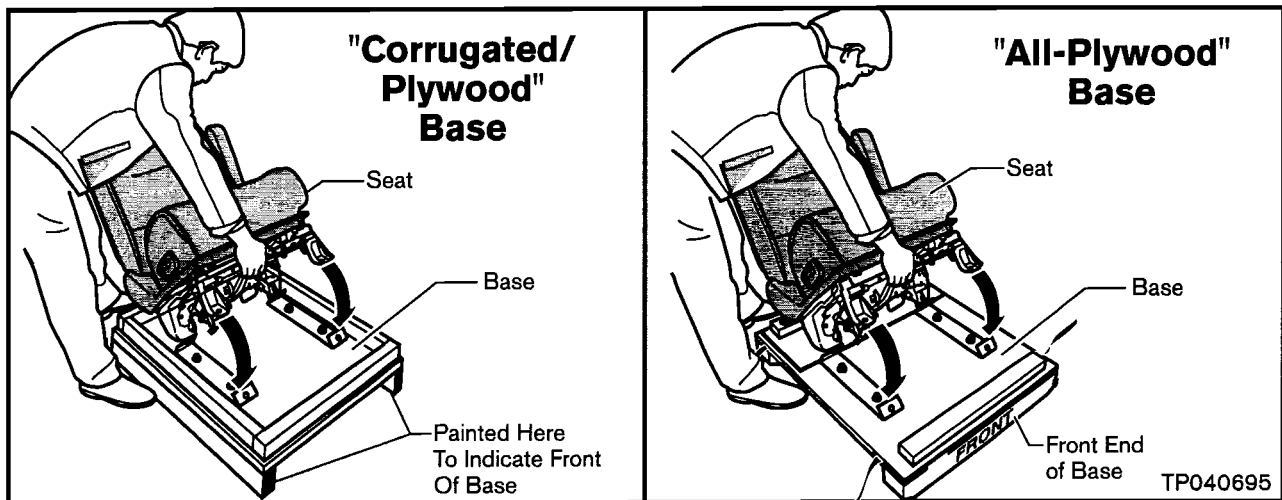

- b. Mount the seat to the Base of the Seat Packaging Crate with the provided nuts, bolts, and washers (see Figure 10).

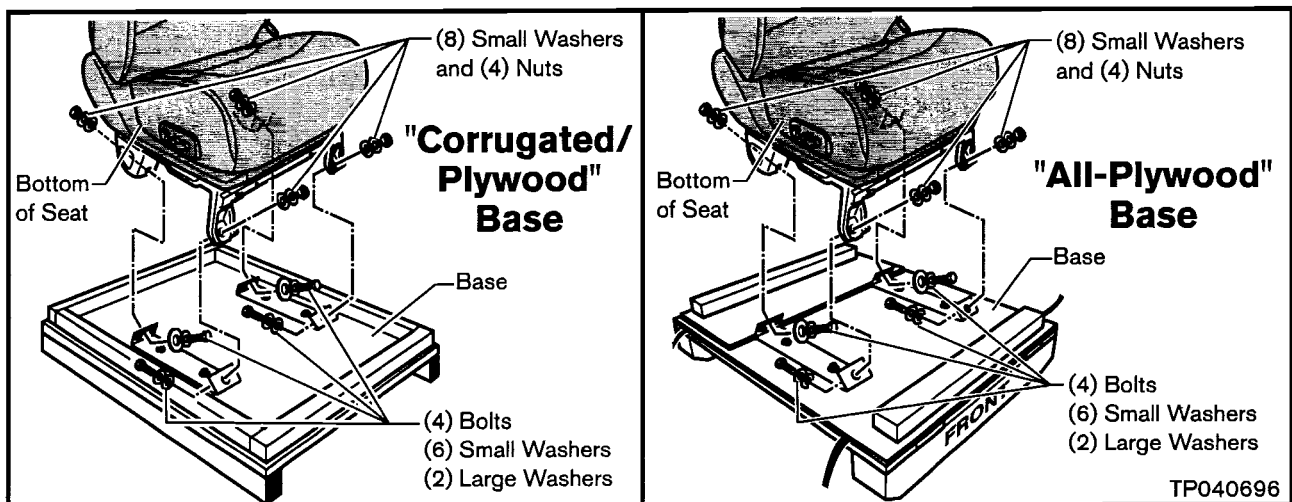

Remove Head Restraint

IMPORTANT: The head restraint must be removed from the seat prior to shipment. The Seat Packaging Crate is designed for shipment of the seat only.

15. Remove the head restraint from the seat as follows:

- a. Press the Release Button and raise the head restraint to the highest position.
- b. Use a Plastic Pry Tool to release (move towards the middle of the seat) the Spring Clip from the Notch on the outboard Head Restraint Holder (see Figure 11).

CAUTION: Use care not to damage the seat covering material when releasing the Spring Clip.

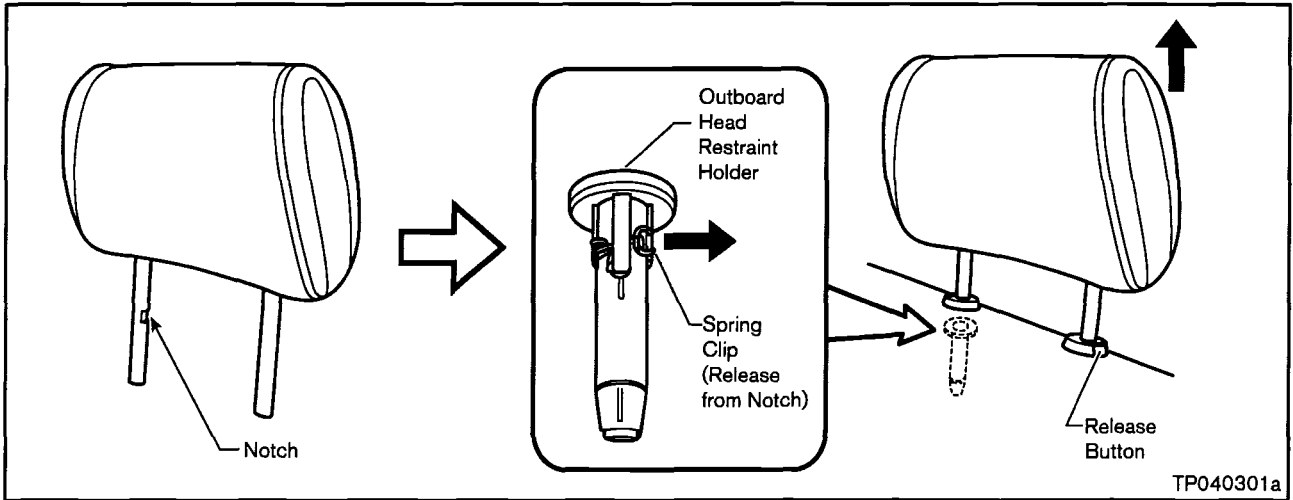

Figure 11

- c. Press the Release Button again and pull up on the head restraint to remove it.
- d. Place the head restraint in the vehicle.

CAUTION: The head restraint **MUST** be removed from the seat and kept with the vehicle.

16. Remove any of the customer's personal items from the seat and place them in the vehicle.

17. Install the plastic cover over the seat.

18. The seat is now ready to be shipped by your Parts Department. Take the seat/crate base to your Parts Department (or Shipping Department) for shipment to the re-calibration facility. The vehicle should be parked in a safe location until the seat returns.

Package / Ship Seat:

There are two types of Seat Packaging Crates that will be sent to your Parts Department:

- Corrugated/Plywood Seat Packaging Crate (see Figure 12a)
- All-Plywood Seat Packaging Crate (see Figure 12b)

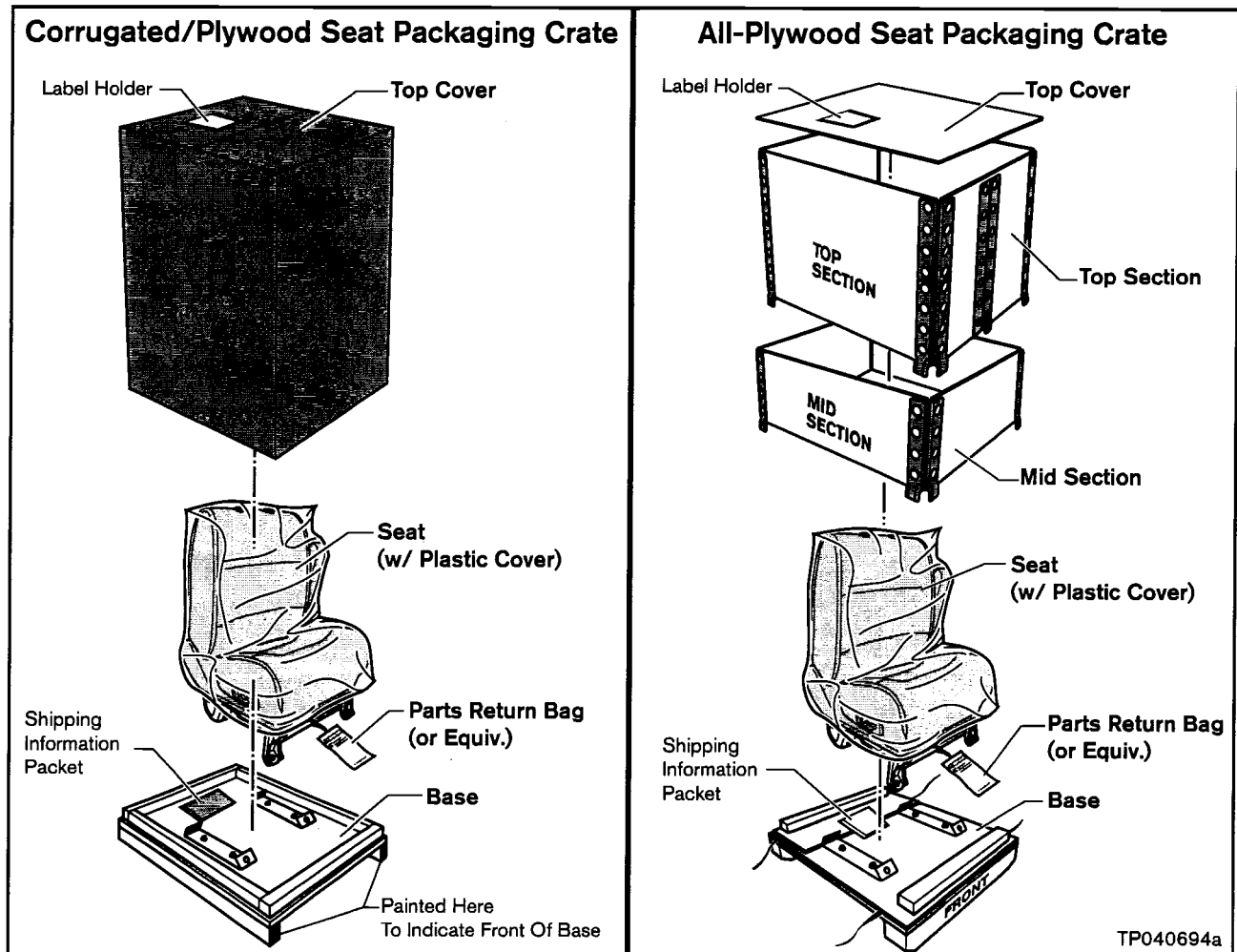

Figure 12a

Figure 12b

Nissan places a Shipping Information Packet in every Seat Packaging Crate shipped to your dealership. The information and materials contained in the packet are to be used when you are ready to ship the seat to the re-calibration facility.

The Shipping Information Packet contains the following:

a. Reusable Seat Packaging Crate Reminder (See Figure 13)

- The Seat Packaging Crates used in this campaign are reusable. This sheet is included to make sure this message is communicated throughout your dealership.

b. Seat Inspection Form (See Figure 1)

- When completed, the Seat Inspection Form should contain the following information:
 - **Last six digits of the Vehicle Identification Number (VIN)**
 - **Dealer Code**
 - **FedEx Airbill number or DDS carrier name**
 - **Indication (written notes) of any pre-existing damage, marks, etc.**

c. FedEx Airbill (See Figure 14)

- A preprinted FedEx Airbill is supplied to facilitate the shipping process and all shipments are billed to a 3rd Party Account Number. The preprinted Airbills contain the address where the seat is to be shipped to. If your dealership is located in Southern California, the packet does not contain a FedEx Airbill. You will need to complete a Bill of Lading (see Figure 15).

NOTE: If the preprinted Airbill is misplaced or lost, an Airbill can be obtained directly from your local FedEx office or any Kinko's location. Complete the Airbill per the sample (Figure 14), using the following Ship To information:

Mallory Alexander International Logistics
4834 S. Mendenhall Road
Memphis, TN 38141
901-363-7200 (Option 2)

NOTE: This address is subject to change.

d. Shipping Procedure

- A copy of the FedEx Standard Operating Procedures (SOP) is included in the packet. If your dealership is located in Southern California, the packet may not contain the FedEx SOP.

e. Shipment Status - Damage Report Form (See Figure 16)

- This form is to be used if a seat is not returned to your dealership in a reasonable time (more than 4 business days) or to report damage to the Seat Packaging Crate or to the Quest Seat during transit. The form is also used to provide additional comments or requests related to the seat re-calibration process.

f. Packaging Straps/Metal Buckles (For Corrugated/Plywood Seat Packaging Crate)

- New Plastic Packaging Straps and Metal Buckles are provided only in the Packet for the Corrugated/Plywood Seat Packaging Crate.

A large plastic cover is provided to cover the seat during seat removal and shipment to and from the Nissan re-calibration center. This plastic cover is re-usable.

Important: This Seat Packaging Crate is designed for multiple trips to and from the central re-calibration facility.

Do not dispose of this Seat Packaging Crate until Nissan notifies you that it is no longer needed. If you have not used this crate in the last 30 days, please shrink wrap and return it to the central re-calibration facility or your facing PDC.

Keep this envelope with the Seat Packaging Crate.

The contents of this envelope are to be used when you are ready to ship the "next" Quest seat to the central re-calibration facility.

Figure 13

TP040417

FedEx USA Airbill

1 From Please print and print hard. Sender's FedEx Account Number

Date _____

Sender's Name _____ Phone () _____

Company _____

Address _____

City _____ State _____ ZIP _____

2 Your Internal Billing Reference (2)

3 [Shaded area for internal billing reference]

Try online shipping at fedex.com

By using this Airbill you agree to the service conditions on the back of this Airbill and in our current Service Guide, including terms that limit our liability.

Questions? Visit our Web site at fedex.com or call 1.800.Go.FedEx.® 800.463.3330.

Sender's Copy

4a Express Package Service Packages up to 150 lbs. Delivery commitment may be later in some areas.

FedEx Priority Overnight Next business morning FedEx Standard Overnight Next business afternoon FedEx First Overnight Earliest next business morning delivery to select locations

FedEx 2Day Second business day FedEx Express Saver Third business day

Public Services may not be available. Minimum charge. Occasional rate.

4b Express Freight Service Packages over 150 lbs. Delivery commitment may be later in some areas.

FedEx 1Day Freight* Next business day FedEx 2Day Freight Second business day FedEx 3 Day Freight Third business day

* Call for Confirmation. * Declared value limit \$500

5 Packaging

FedEx Envelope* FedEx Pak* Includes FedEx Small Pak, FedEx Large Pak, and FedEx Sturdy Pak Other

6 Special Handling Includes FedEx address in Section 5.

SATURDAY Delivery Available ONLY for FedEx 1Day and FedEx 2Day to select ZIP codes. HOLD Wednesday at FedEx Location NOT Available for FedEx First Overnight. HOLD Saturday at FedEx Location Available ONLY for FedEx Priority Overnight and FedEx 2Day to select ZIP codes.

Does this shipment contain dangerous goods? One box must be identified.

No Yes (per shipper's Declaration and Federal) Yes (per shipper's Declaration and Federal) Dry Ice (IATA, ICAO, IAW, IAW, IAW)

Dangerous Goods (including Dry Ice) cannot be shipped in FedEx packaging. Cargo Aircraft Only

7 Payment Bill to: Enter FedEx Account No. or Credit Card No. below.

Sender Recipient Third Party Credit Card Cash/Check

Phone Area No. 2912-1468-1 Fax No.

3 Total Packages: 1 Total Weight: 151 Total Declared Value: \$ 0.00

* Our liability is limited to \$500 unless you declare a higher value. See back for details. FedEx Use Only

8 Release Signature Sign to authorize delivery without obtaining a signature and sign it manually and add no less than any resulting charges. (4) 447

Rev. Date: 06/07/07 FedEx Form 420 (07/06-2007) FedEx PRINTED IN U.S.A. TCEB 02

The information in this shaded area will be pre-printed.

TP040218aa

Figure 14

NOTE: The pre-printed Airbill will contain the "Ship To" name and address information. However, if the preprinted Airbill is misplaced or lost, an Airbill can be obtained directly from your local FedEx office or any Kinko's location. Complete the Airbill per the instructions on page 19.

Shipment Status / Damage Report Form

**Quest Front Passenger Seat (ODS) Campaign
Shipment Status / Damage Report Form**

Dealer Name: _____

Dealer Code: _____

Requestor: _____

VIN (Last 6): _____

Request for Seat Shipment / Re-Calibration Status

Use this portion to obtain status of seat re-calibration

Airbill Number: _____

Report of Seat Packaging Crate / Seat Damage

Use this portion to report any damage to the shipping crate during transit

- Corrugated Shipping Crate was damaged during transit but the base is usable for next seat shipment. Please send replacement cardboard.
- Corrugated Shipping Crate was damaged during transit and the base is NOT usable. Please send a replacement shipping crate.
- Wood Shipping Crate was damaged during transit and shipping crate is NOT usable. Please send a replacement shipping crate.

Note: If you are requesting a replacement shipping crate, please shrink wrap the damaged crate and return it to the re-calibration facility.

Use this portion to report any damage to the seat during transit

- Seat was damaged and is repairable at the dealership.
Repair Order: _____
- Seat was damaged but can NOT be repaired at the dealership. Seat is being returned to re-calibration facility.

Use this portion for Additional Comments/Requests: _____

Send the completed form to:

Memphis, TN facility
Fax: (901) 363-2040
Email: elesah@mdclogistics.com

TP040416b

Figure 16

19. Parts/Shipping Department: Finish packing up the Seat Packaging Crate and send it to the Re-Calibration Facility as follows:

- The Seat Packaging Crate that is sent to your dealer contains the necessary shipping information you'll need to send the seat to the Re-Calibration facility.
- Most dealers will send the seat using FedEx. In this case, a FedEx USA Airbill will be included in the crate (remove the Airbill from the crate). The address of the re-calibration facility is pre-printed on the provided Airbill.
- Please use the applicable shipping procedure (FedEx or DDS) as described on the following pages.

For the Corrugated/Plywood Seat Packaging Crate:

NOTE: Before you proceed with the next step, make sure:

- The seat is properly/securely packaged in the Seat Packaging Crate.
 - The Seat Inspection Form is put into a Parts Return Bag (or equivalent) and attached to the lower frame of the front passenger seat.
- a. Carefully install the Top Cover onto the base (see Figure 17a).
 - b. Tighten the Top Cover down with Plastic Packaging Straps and Metal or plastic Buckles (disposable type) so that the buckles are positioned on top of the Crate. See Figure 17a.

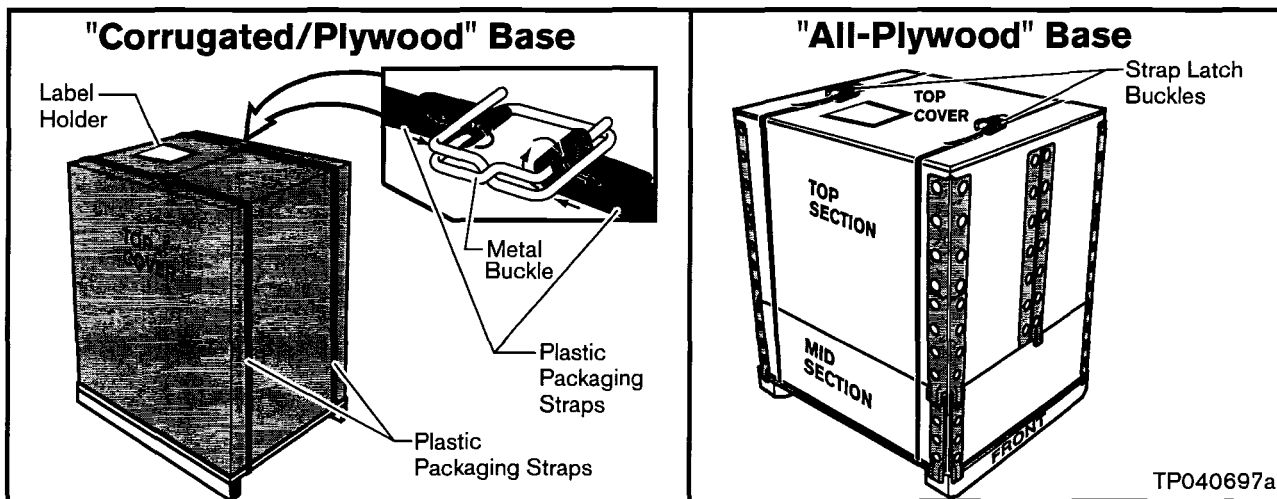

Figure 17a

Figure 17b

For the All-Plywood Seat Packaging Crate:

NOTE: Before you proceed with the next step, make sure:

- The seat is properly/securely packaged in the Seat Packaging Crate.
 - The Seat Inspection Form is put into a Parts Return Bag (or equivalent) and attached to the lower frame of the front passenger seat.
- a. Carefully install the Mid Section onto the Base (see Figure 17b).
 - b. Then, carefully install the Top Section onto the Mid Section (see Figure 17b).
 - c. Carefully install the Top Cover onto the Top Section (see Figure 17b).
 - d. Tighten down the re-useable Straps so the Latch Buckles are positioned on top of the Crate (see Figure 17b).

FedEx Shipping Procedure:

20. Complete the FedEx USA Airbill (see Figure 14) as follows:

- a. Enter your dealership name, address, and phone number at the number 1 location.
- b. **Write down your Dealer Code and the last six digits of the Vehicle Identification Number (VIN) at the number 2 location.**
- c. Enter the Total Packages (1), Total Weight (151 lb.), and Total Declared Value (\$0) at the number 3 location.
- d. Have the Parts Manager sign at the number 4 location.

NOTE: Use a separate Airbill for each seat being shipped.

NOTE: If the preprinted Airbill is misplaced or lost, an Airbill can be obtained directly from your local FedEx office or any Kinko's location. Complete the Airbill per the sample (see Figure 14).

21. Call 1-800-332-0807 to request a pick-up for "Express Freight F-1" shipment. This is an airfreight shipment and you must specify your exact service requirement to the FedEx customer service agent. Write down the customer service agent's first and last name for reference.

IMPORTANT: Do NOT ship via "FedEx Freight". Shipments via "FedEX Freight" are subject to charge back.

22. Obtain the pick-up number and booking number from the FedEx agent to make sure the freight will move overnight.

23. Provide the following information to the FedEx agent: shipper's address, consignee zip, exact package dimensions, skid count, and the account number.

24. Please call for a pick-up by 1:30 PM. If your zip code is in an H-3 FedEx Express Freight pick up and delivery area, you may need to call earlier. If you are not sure if you are in an H-3 area or not, contact the "800" number listed above and provide them with your zip code.

25. Make sure the airbill is completely filled out and attach it to the top of the Seat Packaging Crate (see Figure 17a or Figure 17b).

NOTES:

- Write the FedEx Airbill Number on the Repair Order or other document that remains with the vehicle while it is at your dealership. This information is necessary if you need to inquire about the status of a seat that has been shipped to the central re-calibration facility.
- You can schedule a pick-up 24 hours in advance. Just provide the time that the package will be ready for pick-up.
- If you have any difficulties that cannot be resolved thru the "800" number, please contact your Nissan Dealer Parts and Service Manager (DPSM).

DDS Shipping Procedure:

26. Fill out the Straight Bill of Lading Form (see Figure 15) as follows:

- a. Enter the Re-Calibration Facility name, address, and telephone number at the number **1** location. Get this information off of the supplied FedEx Airbill.
- b. Enter your dealership name and address at the number **2** location.
- c. Enter the number of packages being shipped at the number **3** location.
- d. Enter the shipping item description at the number **4** location.
- e. Enter the total weight of the packages being shipped at the number **5** location.
- f. **Enter your Dealer Code and the last six digits of the Vehicle Identification Number (VIN) at the number 6 location.**

NOTE: If you're sending more than one seat, make sure you write down the VIN for each seat.

- g. Enter the total number of packages being shipped at the number **7** location.
- h. Enter the emergency contact name at the number **8** location.
- i. Enter the total weight being shipped at the number **9** location.
- j. Have the Parts Manager print their name and sign at the number **10** location.
- k. Print the name of the carrier that will be transporting the goods (i.e. DDS or common carrier name) at the number **11** location.

27. Make sure the Bill of Lading is completely filled out. Then attach it to the top of the seat packaging crate.

28. Place the crate in the specified DDS pickup location.

Inspect Seat After It Returns From Re-calibration

29. Make sure you received the correct seat. Confirm the VIN on the airbill or the Bill of Lading matches the VIN of the vehicle you are working on.

30. Inspect the Seat Packaging Crate for damage.

- If the Seat Packaging Crate has been damaged in transit, complete the Shipment Status / Damage Report Form (Figure 16) and FAX/e-mail the form to the central re-calibration facility noting all damage.
- If only the cardboard from the Corrugated/Plywood Crate is damaged, request replacement cardboard using the Shipment Status/Damage Request Form.
- If damage to the Seat Packaging Crate is extensive and the crate is no longer usable, shrink wrap the base (including all nuts, bolts, straps, etc.) and return it to the re-calibration center.

31. Open the Seat Shipping Crate and remove the Plastic Cover from the seat.

IMPORTANT: Please save the plastic cover from the re-calibrated seat so it can be used to ship the “next” seat.

32. Inspect the Seat for damage.

- Complete the Seat Inspection Form (contained in the Parts Return Bag that is attached to the lower frame of the seat), indicating any new damage.
- If the Seat has been damaged in transit, complete the Shipment Status / Damage Report Form (Figure 16) and FAX/e-mail the form to the central re-calibration facility.
- Make sure any new damage is repaired, then submit a normal warranty claim.
- If damage to the seat is extensive, contact TechLine.

33. The seat is now ready to be re-installed.

- Replace the plastic cover on the seat and take the seat (still attached to the base) to the Service Department.
- Only the base needs to be sent to the Service Department.
- Keep the cardboard/plywood shipping crate covers, straps, and other packaging/shipping material in the parts/shipping department so they will be available to ship the “next” seat to the re-calibration facility.

Re-install Seat And Head Restraint

34. Remove the seat (from the base) and return the Seat packaging Crate to the Parts Department (or other area identified by your dealership) to be used for the "next" seat to be shipped to the re-calibration center.
35. Make sure the ignition switch is **OFF**.
36. Disconnect both battery cables and **wait for at least 3 minutes**.
37. Re-install the seat in the reverse order it was removed, making sure:
 - The Head Restraint is properly re-installed.
 - All vehicle wire harnesses are properly routed and re-connected to the seat (see Figure 8).
 - The seat mounting bolts are tightened to: **45 N-m (4.6 kg-m, 33 ft-lb)**.

Check/Clear Any Stored DTC(s)

CAUTION: Make sure the ignition key is in the **OFF** position and all doors are closed before re-connecting the battery cables (next step).

38. Re-connect both battery cables.
39. From the driver's side, use CONSULT-II to check and delete any stored DTC(s) that are stored in:
 - **Self Diagnosis Past**AND
 - **Self Diagnosis Current**

Check Air Bag Module Warning Light (on Instrument Panel): See Figure 18

40. From the driver's side, turn the ignition key **OFF**, then turn it back **ON** again.
 - a. If the Air Bag Module Warning Light turns **OFF** after 5 – 7 seconds, proceed to "Check Occupant Detection System Warning Light".
 - b. If the Air Bag Module Warning Light does **NOT** turn **ON** at first, does **NOT** turn **OFF**, or if it blinks, refer to the applicable Service Manual for diagnosis/repair.
 - c. Turn the ignition key **OFF**, then proceed to "Check Occupant Detection System Warning Light".

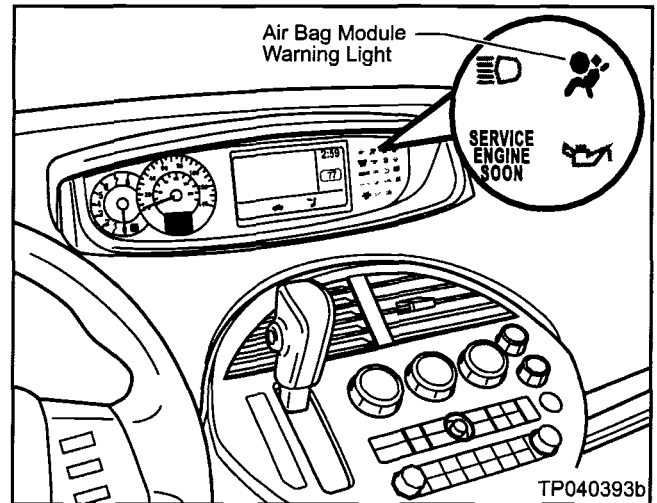

Figure 18

Check Occupant Detection System Warning Light (on Instrument Panel): See Figure 19

41. With no one sitting in the passenger front seat, turn the ignition key **ON**.
42. Confirm the Occupant Detection System Warning Light turns **ON**.
43. Have someone (an average male who weighs approximate 171 lbs) sit in the passenger front seat in accordance with the recommended seating position in the Owners Manual.
44. Confirm the Occupant Detection System Warning Light turns **OFF** (after approximately 7 seconds).
 - a. If the Occupant Detection System Warning Light correctly operates (as described above), proceed with "Check Seat/Components Operation" (next page).
 - b. If the Occupant Detection System Warning Light does **NOT** correctly operate (as described above), refer to the applicable Service Manual for diagnosis/repair. Then, proceed with "Check Seat/Components Operation" (next page).

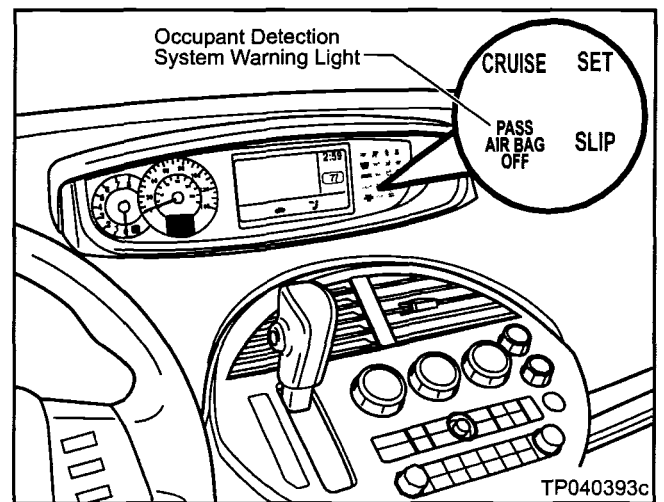

Figure 19

Check Seat/Components Operation

45. Make sure all functions of the Front Passenger Seat operate properly.

46. If equipped, make sure the DVD Player and Navigation system work properly.

“Re-Initialize” Power Sliding Door (if applicable)

NOTE: The following procedure is for one sliding door. It must be repeated (if needed) on a second door.

47. Open the sliding door.

48. Turn the ignition key ON.

49. Turn the Automatic Door Main Switch OFF (see Figure 20).

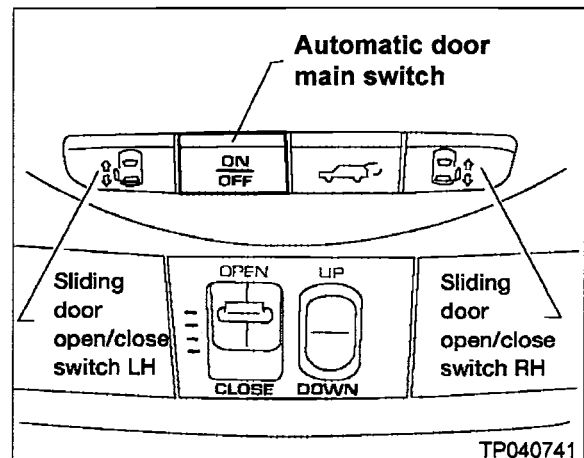

Figure 20

50. Within 3 seconds after step 49, press the sliding door B-pillar switch (LH or RH, depending on which door you are initializing) 10 times within 10 seconds.

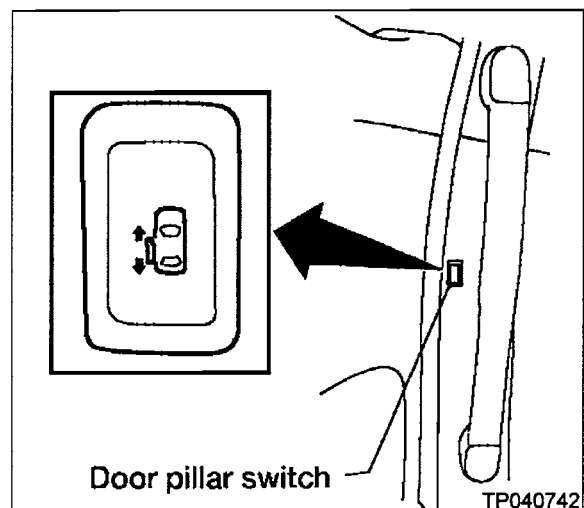

Figure 21

51. Within 3 seconds after step 50, turn the ignition key OFF → ON.

- You should hear three (3) sliding door warning chimes.
- The three chimes indicate the controller has entered initialization mode.
- Normal door functions are disabled during initialization.

52. Turn the Automatic Door Main Switch ON (see Figure 22).

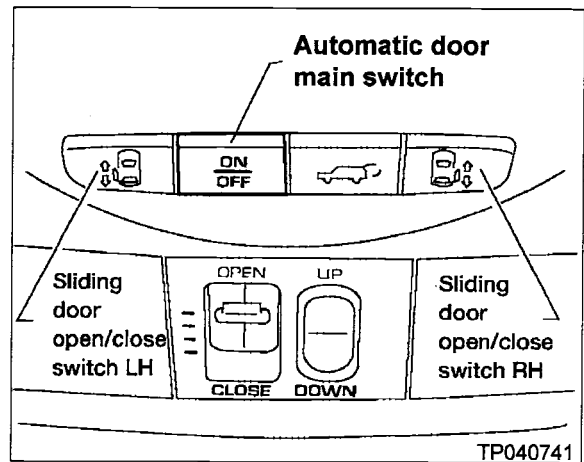

Figure 22

53. Press and hold the driver's overhead Sliding Door Open / Close Switch (LH or RH, depending on which door you are initializing) until the sliding door completely closes and stops; then release the switch.

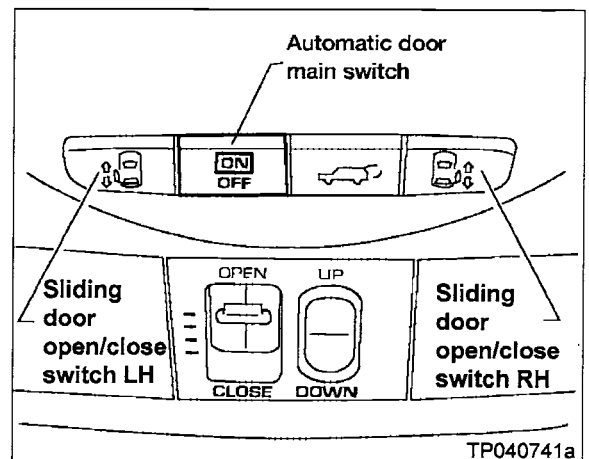

Figure 23

54. Press and hold the same sliding door switch again, until the door completely opens and stops; then release the switch. (Same switch as step 53.)

55. Press and hold the same switch again, until the door completely closes and stops; then release the switch. (Same switch as step 53 and 54.)

56. Turn the ignition key OFF. One sliding door is now initialized.

- The initialized door will now operate normally.
- If needed, repeat steps 47 through 56 for a second sliding door.

Check Sliding Door Operation

57. Perform the Sliding Door final check as follows:

- a. Make sure the Sliding Door properly:
 - opens
 - closes
 - latches
 - stops and reverses if an obstruction is detected (power sliding door only)
- b. Make sure the Child Safety Lever operates properly.
- c. Confirm proper operation of: all applicable sliding door electrical power switches, exterior door handle, and inside push button/lock knob.

NOTE: If the above listed Sliding Door functions do not operate properly, refer to the BL section of the Service Manual for further diagnosis.

Final Steps

58. Re-program all radio station presets.

59. Re-set the clock.

60. Review the Seat Inspection Results with the customer as follows:

- a. Review the seat inspection results with the customer.
- b. Have the customer and the qualified dealer personnel sign the form.
- c. Keep a copy of the form with the Repair Order and give a copy to the customer.

NOTE: If there was no new damage found on the seat (after it was returned from being re-calibrated), go ahead and perform the above steps so an "official record" is on file indicating that there was no new damage.

61. If applicable, reset the Sunroof memory as follows:

- a. Push the Sunroof Tilt Switch in the tilt DOWN position (repeat as necessary) until the Sunroof is fully closed. See Figure 24.
- b. Then, push and hold the Sunroof Tilt Switch (see Figure 24) in the tilt DOWN position for more than 2 seconds.
- c. Reset is complete.

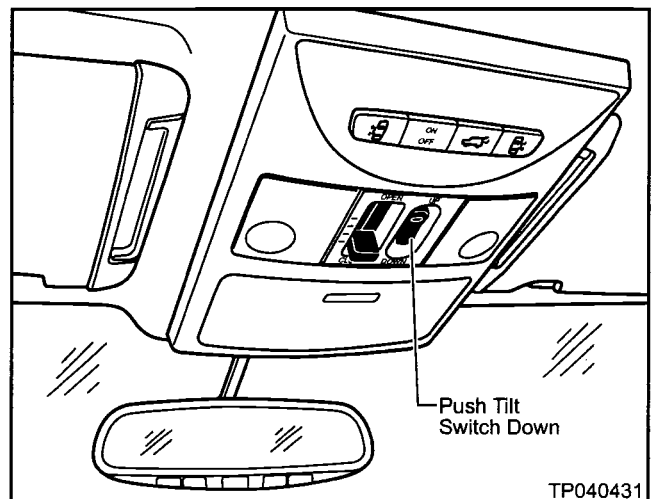

Figure 24

CLAIMS INFORMATION

Submit a Campaign ("CM") line claim using the following claims coding information:

Campaign I.D.: B0112

DESCRIPTION	OP CODE	FRT
Remove seat, inspect, package, ship, un-package, inspect & re-install	B01122	0.8 hrs

Expense Codes:

EXPENSE CODE	DESCRIPTION	MAX. AMOUNT
502	Rental Car	Up to \$45.00/day + tax + surcharge*, for up to 5 days**

* Some areas serviced by Enterprise Rent-A-Car may include a surcharge, which will be included in the invoice from Enterprise.

** If Rental Car is required for more than 5 days, contact the Warranty Claim Call Center.

Additional information related to the national agreement with Enterprise-Rent-A-Car follows:

Reservations:

- It is recommended you make all rental reservations through the Enterprise toll free number 1-877-722-0097.
- We also recommend that you determine specific customer rental vehicle requirements at the time the customer appointment is scheduled. This information will be helpful when you contact Enterprise.
- Each reservation is processed by a specially trained team at the Enterprise call center in St. Louis. The reservation is immediately sent to the corresponding rental location using a national "Nissan Quest Campaign" source number (QUESTRC)."

Vehicle Delivery:

- Enterprise will provide vehicle delivery with 2-hour advance notice and customer pickup within 10 minutes when notified by your dealership that the customer has arrived for their scheduled campaign appointment.

Rental Vehicle:

- Enterprise will provide rental vehicles based on the following customer priorities:

1st Priority - Nissan Quest, Murano or Maxima

2nd Priority - Similar competitive make utility vehicle (Minivan, SUV), Nissan Xterra or Full Size vehicle

3rd Priority - Nissan Altima

4th Priority - All Others

Daily Rates:

- Enterprise will provide vehicles at the following daily rental rates:

Vehicle	Daily Rental Rate
Nissan Quest, Maxima & Murano	\$45 + Tax & local surcharges
Competitive Vans, SUVs (including Xterra) & Full size class vehicles or higher	\$40 + Tax & local surcharges
Nissan Altima	\$35 + Tax & local surcharges
All Others including Sentra	\$30 + Tax & local surcharges

Contact your local Enterprise office to determine if any local surcharges are applicable to your area.

Rental Periods:

- Nissan dealers are authorized to provide up to 5 days of car rental.
- If additional time is required, prior approval must be obtained from the Nissan Warranty Claim Call Center.

Billing:

- Enterprise will invoice your dealership at the close of each rental event.
- See the Claims Information section of the Quest Front Passenger Seat Occupancy Detection System Recall Campaign Bulletin for specific instructions on how to submit the claim for car rental.

Reporting:

- Enterprise will provide a nightly report to NNA of all open rental tickets by dealership for analysis by NNA to ensure the appropriate vehicle has been provided.

Grace Period:

- When a customer returns the rental vehicle, Enterprise will allow a minimum grace period of 2 hours.
- This will provide a 26-hour rental day on the last day of the rental event.
- Individual Enterprise Branch offices may extend the 2-hour grace period at their discretion.
- Billing for rental events will be based on 24-26 hour periods and not on a calendar day basis.

Free Mileage:

- Enterprise will include a minimum of 150 free miles per rental day.
- Individual Enterprise branch offices may extend the 150 free miles at their discretion.

Protection Products:

- In those states where permitted by law, Enterprise may offer optional insurance products to Nissan customers; payment for optional insurance products will be the responsibility of the Nissan customers.

OWNER'S LETTER

Dear Nissan Owner:

This notice is sent to you in accordance with the requirements of the National Traffic and Motor Vehicle Safety Act. Nissan has decided that some 2004 Nissan Quest vehicles fail to conform to Federal Motor Vehicle Safety Standard (FMVSS) 208 – Occupant Crash Protection.

REASON FOR RECALL

FMVSS 208 regulates vehicle restraint systems, including air bags. One part of the regulation requires the air bag for the front passenger seat to be turned off (so that it does not inflate) when certain occupants, such as small children, are in the front seat. This prevents such occupants from being injured by an inflating air bag in a collision.

To do this, the front passenger seat has an Occupant Detection System (ODS). The ODS measures the pressure on the seat when it is being used and turns the air bag on or off as required by the standard. (A light on the dashboard will glow and indicate "Pass Air Bag OFF".) One test under the standard is to place a dummy about the size of an average six-year old child on the passenger seat and make sure the air bag turns off. Nissan has found that the ODS may not work properly in this test. If the ODS does not turn the air bag off, there is an increased risk of injury from an inflating air bag in some situations. We would like to correct your vehicle to ensure proper operation.

WHAT NISSAN WILL DO

Your Nissan dealer will remove the front passenger seat and ship it in a special container to a facility which will modify the Occupant Detection System and then return the seat to the dealer. This free service should take about one week to complete and your vehicle will be inoperable during this period. Your dealer will arrange for alternate transportation from Enterprise Rent-A-Car or other agency until your Quest is returned to you. To ensure availability, you will need to schedule an appointment. The alternate transportation, exclusive of any optional insurance you elect to purchase, will be provided free of charge.

WHAT YOU SHOULD DO

Contact your Nissan dealer at your earliest convenience in order to arrange an appointment to have your vehicle repaired. **It is essential that you have an appointment before bringing your vehicle to the dealer in order to ensure that the dealer will be able to take your vehicle that day for the recall repair.** Please bring this notice with you when you keep your service appointment. Instructions have been sent to your Nissan dealer.

Important Note: As outlined in your owner's manual, changes to the front passenger seat should not be made, because they can affect proper operation of the ODS system. If the passenger seat has been changed from its original factory specifications (such as replacing the original seat material), the seat must be returned to the original factory condition prior to having this campaign repair completed by your Nissan dealer. Any aftermarket accessories such as seat covers or video screens installed in the front seat head restraints must be removed before you bring the vehicle to your Nissan dealer for the scheduled appointment.

Even with the Occupant Detection System in your Quest, Nissan recommends that children 12 and under be properly restrained in a rear seat using a child restraint, booster seat, or vehicle seat belt, as appropriate for the child's size. According to accident statistics, children are safer when properly restrained in the rear seat than in the front seat. You should especially follow this recommendation until the front passenger seat is repaired.

If the dealer fails, or is unable to make the necessary repairs free of charge, you may contact the National Consumer Affairs Office, Nissan North America, Inc. at P.O. Box 191, Gardena, California 90248-0191. The toll free number is 1-800-753-9781. You may also contact the Administrator of the National Highway Traffic Safety Administration, 400 Seventh Street SW, Washington, D.C. 20590 or call the toll free Safety Hotline at (888) 327-4236.

Federal law requires that any vehicle lessor receiving this recall notice must forward a copy of this notice to the lessee within ten days.

Thank you for your cooperation. We are indeed sorry for any inconvenience this may cause you.
