

**ISUZU**

RECEIVED  
66-215

JUN 19 11:00 AM  
DET.04-068

OFFICE OF  
DEFECTS INVESTIGATION

July 15, 2004

Mr. Kenneth N. Weinstein  
Associate Administrator for Safety Assurance - NSA-01  
National Highway Traffic Safety Administration  
400 Seventh Street, SW - Room 5321  
Washington D.C. 20590

Subject: MY 2003 Isuzu Ascender -  
Windsheld Wiper Module -  
Part 573 Defect Information Report -  
Recall 04V-061 -  
Supplemental Submission

Dear Mr. Weinstein:

On behalf of Isuzu Motors Limited, Isuzu Manufacturing Services of America, Inc. hereby makes this supplemental submission relevant to Recall No. 04V-061 referenced above. Per the requirements of 49 CFR §573.6(c)(9), attached here are representative copies of all notices, bulletins, and other communications that relate to this recall that have been sent to more than one manufacturer, distributor, dealer or purchaser and includes the dealership executive management notice, the campaign bulletin and the owner letter.

If you have any questions or require additional information, please contact me at 734-582-9262 or Christine Ueno of my staff at 734-582-9260.

Sincerely,

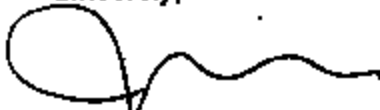

Jeffery A. Marsee  
Chief Representative  
Emissions and Safety  
Isuzu Manufacturing Services of America, Inc

/cfu

Enclosures

July 8, 2004  
Campaign 04V-061  
Bulletin SB04-04-S002

**ASCENDER WINDSHIELD WIPER OPERATION  
SAFETY RECALL CAMPAIGN  
04V-061**

**To: All Isuzu Dealer Service Managers and Parts Managers**

This letter, Campaign Service Bulletin SB04-04-S002 and Campaign Report AWS123-1A are being sent to you to notify you of a Campaign affecting certain Isuzu Ascender vehicles.

**Affected Vehicles:**

Certain 2003 Isuzu Ascender (US) models.

**Condition:**

The manufacturer General Motors has decided that a defect, which relates to motor vehicle safety, exists in certain 2003 Isuzu Ascender vehicles. Under certain conditions, water may seep into the windshield wiper module. If this were to happen, it could result in windshield wipers that will not turn on, cease operation while driving, fail to turn off, turn on by themselves, and/or continuous windshield washer pump operation. Improper operation of the windshield wiper system in a severe weather situation could reduce the driver's visibility, and could cause a vehicle crash without prior warning.

**Dealer Action:**

Isuzu dealers will inspect and seal the windshield wiper motor as outlined in Campaign Bulletin SB04-04-S002. In some cases, after inspection, the windshield wiper module may require replacement. Once you have been contacted by a customer to schedule an appointment we ask that you immediately order the part so that the repair can be completed in a timely manner. Additionally, be advised that the seal assembly part involved in this repair has a shelf life of one year.

**OWNER NOTIFICATION:**

**OWNER NOTIFICATION WILL BEGIN July 15, 2004.**

Please ensure that all appropriate personnel within your dealership are aware of this campaign and that the necessary repairs are performed on all affected vehicles either in your inventory or brought into your dealership for repair.

To confirm that a vehicle has an applicable campaign you can validate the VIN through ICS on the VIN inquiry screen.

# ISUZU

# Campaign Service

## BULLETIN

### IMPORTANT SERVICE INFORMATION FOR:

- ✓ SERVICE MANAGER
- ✓ SERVICE ADVISOR
- ✓ TECHNICIAN
- ✓ PARTS DEPARTMENT
- ✓ WARRANTY PERSONNEL



SB04-04-S002

**BULLETIN NUMBER:**  
SB04-04-S002

**ISSUE DATE:**  
JULY 2004

**GROUP:**  
ELECTRICAL

### WINDSHIELD WIPER OPERATION SAFETY CAMPAIGN 04V-061



SUV

#### CAMPAIGN IDENTIFICATION NUMBER

Number 04V-061 has been assigned to this campaign by the National Highway Traffic Safety Administration (NHTSA). This number will appear on all communications and documentation of any nature dealing with the campaign.

#### AFFECTED VEHICLES

Certain 2003 Isuzu Ascender (US) vehicles within the following VIN range 092100381-X32100366.

#### SERVICE INFORMATION

##### **Condition:**

The manufacturer General Motors has decided that a defect, which relates to motor vehicle safety, exists in certain 2003 model year Isuzu Ascender vehicles. Under certain conditions, water may seep into the windshield wiper module. If this were to happen, it could result in windshield wipers that will not turn on, cease operation while driving, fail to turn off, turn on by themselves, and/or continuous windshield washer pump operation. Improper operation of the windshield wiper system in a severe weather situation could reduce the driver's visibility, and could cause a vehicle crash without prior warning.

##### **Correction:**

Dealers are to inspect and seal the windshield wiper motor. In some cases, the windshield wiper module may require replacement.

#### DEALER RESPONSIBILITY

Isuzu dealers are required to service all eligible vehicles at no charge to the owner, regardless of mileage, age of vehicle or ownership.

Whenever a vehicle subject to this campaign is in a dealer's vehicle inventory, or arrives at the dealership for service, the dealer must take the necessary steps to ensure that this campaign correction has been made before selling or releasing the vehicle.

Each Isuzu dealer will be supplied a copy of the AIMI Campaign Report (AWS-123-1A) listing affected vehicles assigned to that dealership. The report contains VIN and detailed owner information obtained from state motor vehicle registration records. The use of such motor vehicle registration data for any other purpose is a violation of the law in several states. Accordingly, dealers are urged to limit the use of this listing to the follow-up necessary to complete this campaign. If none of the affected vehicles

This Service Bulletin is intended for use by professional, qualified technicians. Attempting repairs or service without the appropriate training, tools, and equipment could cause injury to you or others and damage to your vehicle that may cause it not to operate properly.



CAMPAIGN IDENTIFICATION CAMPAIGN IDENTIFICATION CAMPAIGN IDENTIFICATION CAMPAIGN IDENTIFICATION

are assigned to a dealership, no campaign report will be sent.

### OWNER NOTIFICATION

Isuzu Motors America Inc. will send a notification letter to owners of affected vehicles already retailed (see enclosed copy). Dealers should follow up with vehicle owners by sending a Campaign Reminder Notice (AIMI SVCF-1052) to all vehicle owners listed in the AIMI Campaign Report (AWS-123-1A). Dealers may obtain these postcards from their Regional Office.

### SERVICE PROCEDURE

The following procedure provides instructions for inspecting the windshield wiper module, installing a breathable seal to the vent on the wiper motor cover if applicable, or if necessary, installing a new windshield wiper module.

### INSPECTION PROCEDURE

1. Using a flashlight, look down through the air inlet screen at the location shown (see figure 1).

- If the color of the can on the wiper motor is **SILVER** (see figure 1), no repairs are required on the vehicle, proceed to the section titled, **APPLYING THE CAMPAIGN LABEL**.
- If the color of the can on the wiper motor is **BLACK** (see figure 1), proceed to the section titled **REPAIR PROCEDURE**.

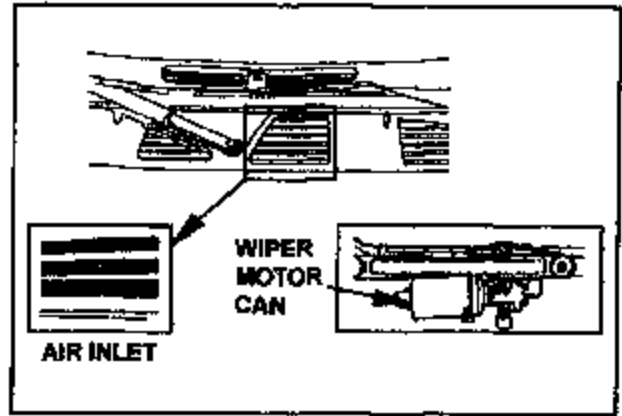

Figure 1

### REPAIR PROCEDURE

1. Verify that all of the functions of the wiper system (low, high, delay, etc.) operate properly.
2. Turn the key to the off position.
3. Open the hood.
4. Remove the three push-in retainers that attach the air inlet grille (leaf screen) to the plenum sheet metal (see figure 2).

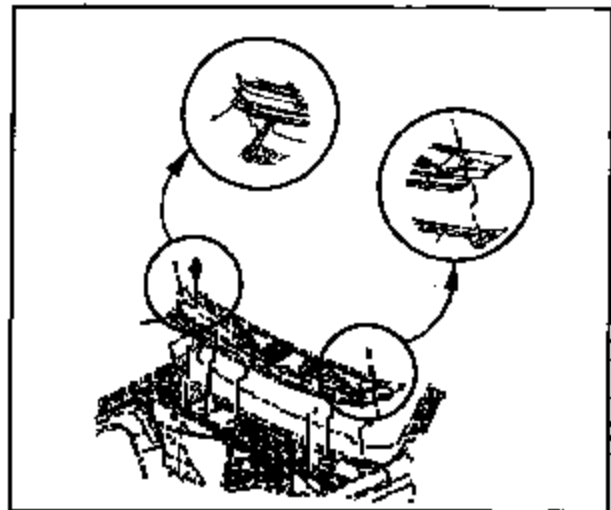

Figure 2

5. Lower the hood to the secondary latch.
6. Using a suitable marker or masking tape, mark the location of both wiper blades on the windshield.
7. Remove the covers from the nuts that attach the wiper arms.
8. Remove the nuts from the wiper arms.
9. Rock the wiper arms back and forth to loosen and remove them from the wiper transmission shaft. **NOTE: If the rocking action fails to loosen the wiper arm, it may be necessary to use a standard top-post battery cable terminal puller to remove the wiper arm.**
10. Remove the antenna mast if applicable.
11. Remove the 10 mm hex head nut that attaches the left and right ends of the air inlet grille to the plenum sheet metal (refer to figure 2).
12. Remove the air inlet grille and reposition it up to the windshield. It is not necessary to disconnect the washer hose. **NOTE: Use caution not to damage the washer hose.**
13. Remove the two 10 mm hex head bolts that attach the wiper module to the plenum sheet metal (see figure 3).

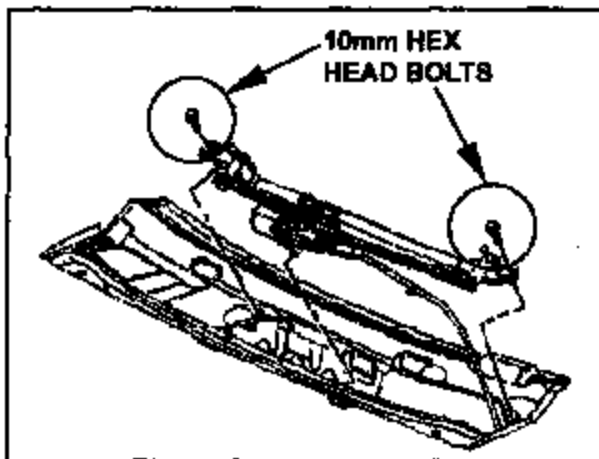

Figure 3

14. Disconnect the electrical connector.
15. Remove the wiper module and place on a suitable work surface.
16. Inspect the inside of the electrical connector on the wiper motor for moisture or water. If no moisture or water is found, continue inspecting for evidence or signs that moisture or water was present at some earlier time. Indicators include water stains, dried dirt, etc (see figure 4).
  - If moisture or water is found in the electrical connector, or if there is evidence that there was moisture or water present at an earlier time, the complete wiper motor module (including the motor) **MUST** be replaced. Obtain a new wiper module and proceed to Step 20. The new wiper modules already have a different style of breathable seal on the wiper cover. **DO NOT** install the breathable seal described later in this recall on new wiper modules.
  - If there is no moisture or water found in electrical connector, or if there is **NO** evidence that moisture or water was present at an earlier time, a breathable seal must be installed over the vent in the wiper motor cover. Proceed to the next step.

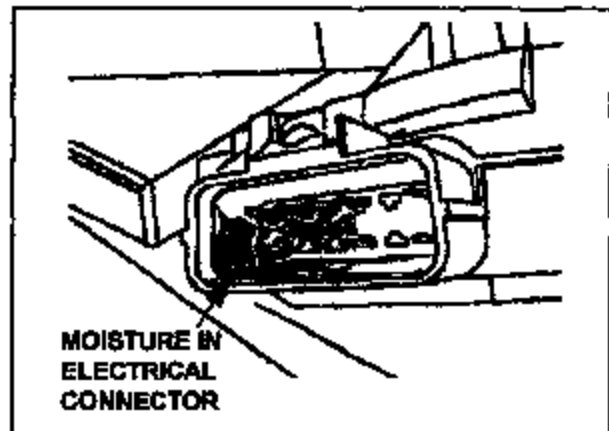

Figure 4

17. Clean the exterior surface of the wiper motor cover thoroughly. It must be free of dirt, grease, oil, and other contamination (see figure 5).

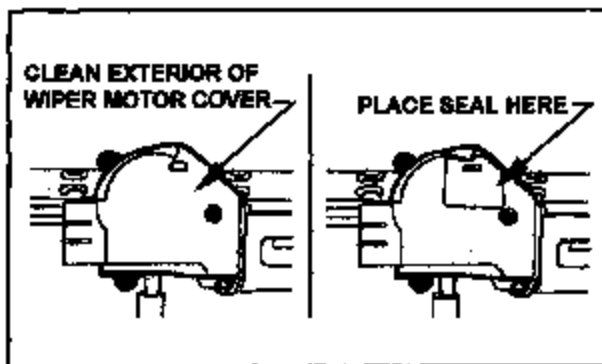

Figure 5

**IMPORTANT:** To ensure good adhesion of the seal being installed, make sure that your hands are clean and free of oil and grease before proceeding.

18. Using the alcohol wipe included in the kit, wipe the complete exterior surface of the wiper cover thoroughly. Allow the surface to dry approximately 30-45 seconds before proceeding.

**IMPORTANT:** When using the adhesion promoter:

- **DO NOT** open the adhesion promoter until you are ready to apply it.
  - Use the complete contents of the packet as soon as it is opened.
  - If the packet is dried-out when opened, obtain another sealer kit or use P/N 8-12378-462-0 (4 oz. can of adhesion promoter).
  - Do not allow the liquid to "spill" inside of the vent opening on the wiper motor cover when applying.
  - Allow to dry 30-90 seconds before applying the seal.
19. Carefully apply the adhesion promoter that is included in the kit.

**IMPORTANT:**

- The seal must be inspected before installing. If there are any creases in the seal or backing material, the seal must NOT be used. Obtain another sealer kit.
- If you are unable to remove the backing material from the seal in the next step, the seal is beyond its shelf life of one year. Obtain another sealer kit. **DO NOT** touch the adhesive surface on the seal when removing the backing material.

20. Remove the backing material from the seal, align it over the wiper motor cover so that it completely covers the vent and press it firmly into place as shown in the above illustration. Apply firm pressure across the entire surface of the seal and around all outside edges. Continue applying pressure a second time to the edges to assure full adhesion (refer to figure 5).

21. Position the wiper module to the vehicle and connect the electrical connector.

22. Install the wiper module in the plenum sheet metal.

23. Install the two 10 mm hex head bolts that attach the module to the plenum sheet metal and tighten the bolts to 8 N·m (71 lb in).

24. Install the air inlet grille to the plenum sheet metal.

25. Install the 10 mm hex head nut that attaches the left and right ends of the air inlet grille to the plenum sheet metal and tighten the nuts to 4 N·m (35 lb in).

26. Install the antenna mast if applicable.

27. If installing a NEW wiper module, turn the ignition switch to the ON position, turn the wiper switch ON, and visually verify that the wiper transmissions operate. After visually verifying operation, turn the wiper switch to the OFF position and allow the wiper transmissions to stop moving before turning the ignition switch to the OFF position. The wiper motor will now be in the PARK position. **NOTE: Wiper motor and transmissions must be in the PARK position before installing the wiper arms.**

28. Using the marks or masking tape that were placed on the windshield, align and position the wiper arms on the wiper transmission shafts.

29. Install the nuts on the wiper transmission shafts and tighten to 30 N·m (22 lb ft).

30. Install the covers on the wiper arm nuts.

31. Remove the marks or masking tape from the windshield.

32. Open the hood.

33. Install the three push-in retainers that attach the air inlet grille to the plenum sheet metal.

34. Close the hood.

35. Verify that all functions of the wiper system (low, high, delay, etc.) operate properly.

#### APPLYING THE CAMPAIGN LABEL

Affix the campaign label P/N 2-90028-700-0 adjacent to the manufacturer's identification label located inside the driver's door. Using a ballpoint pen, fill in the label with campaign number 04V-061, Isuzu dealer code and repair date.

<b>ISUZU</b>	
CAMPAIGN NUMBER	
_____	
DEALER CODE:	_____
REPAIR DATE:	_____
P/N 2-90028-700-0	

#### PARTS INFORMATION

Part Number	Description	Quantity Required
8-10376-669-0	Seal Assy. WSW MOT*	1 (if required.)
8-15094-704-0	Module, WSW Sys (W/O Rain Sense, RPO -CE1)	1 (if required.)
8-15094-705-0	Module, WSW Sys (W/Rain Sense, RPO +CE1)	1 (if required.)

\*Sealer kits have a shelf life of 1 year do not over order.

## WARRANTY CLAIM INFORMATION

Use the following labor operation:

Operation	Operation Number	Task	Time	Failed P/N	Trouble Code
Inspect WSW Module, No Further Action Required	04V1114	Inspect	0.8	N/A	07
Inspect WSW Module & Install Seal Assembly	04V1115	R&R	0.6	8-15094-704-0	07
Inspect WSW & Replace WSW Module	04V1116	R&R	0.6	8-15094-704-0	07

**NOTE:**

- *Labor Time includes administrative time allowance.*
- *Information released on paper and electronic format prior to bulletin release cannot be updated. For the most current and up to date information refer to [IsuzuONE.com](http://IsuzuONE.com).*
- *Always refer to the Isuzu Service Policy Procedure Manual for specific details on warranty coverage and policies.*

NATIONAL SERVICE DEPARTMENT

SB04-04-S002



Dear Isuzu Ascender Owner:

This notice is sent to you in accordance with the requirements of the National Traffic and Motor Vehicle Safety Act. The manufacturer, General Motors, has decided that a defect which relates to motor vehicle safety exists in certain 2003 Isuzu Ascender vehicles.

**□ WHAT IS THE CONDITION?**

Under certain conditions, water may seep into the windshield wiper module of your 2003 Isuzu Ascender. If this were to happen, it could result in windshield wipers that will not turn on, cease operation while driving, fall to turn off, turn on by themselves, and/or continuous windshield washer pump operation. Improper operation of the windshield wiper system in a severe weather situation could reduce the driver's visibility, and could cause a vehicle crash without prior warning.

**□ WHAT WE WILL DO**

To correct this condition, your Isuzu dealer will inspect and seal the windshield wiper motor. In some cases the windshield wiper module may require replacement. This service will be performed for you at no charge.

**□ WHAT YOU SHOULD DO**

To limit any possible inconvenience, and in order to ensure that the necessary parts are obtained, we recommend that you contact your Isuzu dealer as soon as possible to schedule an appointment to bring your vehicle in to have this work performed. Present this Owner Notification Letter at the time of your appointment or refer to Campaign Service Bulletin SB04-04-S002. Isuzu estimates that the repair will take approximately 15 minutes to perform. If the motor requires sealing or replacement, an additional 15 minutes will be required. However, additional time may be necessary depending on how appointments are scheduled and processed at your dealership. To locate the nearest Isuzu dealer you can visit our website at [www.isuzu.com](http://www.isuzu.com) and click on the dealer locator icon and enter your zip code or state. Should you not have access to a computer terminal please contact our National Owner Relations Department.

If you have any problems obtaining the needed repair or believe that this repair has not been or cannot be made within a reasonable time, you may contact:

National Owner Relations Department  
Isuzu Motors America, Inc.  
16323 Shoemaker Ave.  
Cerritos, CA 90702-6032  
1-800-255-6727.

After contacting your Isuzu dealer or the National Office with any problems, if you still are not satisfied with the work performed, you may submit a written complaint to the Administrator, National Highway Traffic Safety Administration, 400 Seventh Street S.W., Washington, D.C. 20590 or call 1-888-DASH-2-DDT (1-888-327-4236).

**□ REIMBURSEMENT**

If you have already paid for some or all of the cost to have the windshield wiper motor repaired or replaced, you should write to Isuzu Motors America, Inc., 16323 Shoemaker, Cerritos, CA 90702, attention National Owner Relations Department. Please provide the original paid receipt or invoice verifying the repair.

We regret any inconvenience which this action may cause you.

Sincerely,  
**ISUZU MOTORS AMERICA, INC.**

**IMPORTANT:** If you have sold or traded your Isuzu vehicle, please enter the owner's name and address, if known, on the attached "Change of Information" postcard, tear off at both perforations, and drop it in the mail. Postage has already been paid. We will contact the new owner.