

**Dealer TO: ALL BUICK, CHEVROLET, OLDSMOBILE AND PONTIAC DEALERS**

**Salutation:**

**ATTENTION: SERVICE MANAGER, PARTS MANAGER AND WARRANTY ADMINISTRATOR**

**GM SERVICE AND PARTS OPERATIONS**

**DCS1135**

**URGENT DISTRIBUTE IMMEDIATELY**

**DATE: February 24, 2004**

**SUBJECT: 04002 / Product Safety Recall Ignition Circuit Thermal Events**

**MODELS: 1998 Buick Skylark  
1998-2001 Chevrolet Cavalier  
1998 Oldsmobile Achieva  
1998 Pontiac Grand Am  
1998-2001 Pontiac Sunfire**

**TO: All Buick, Chevrolet, Oldsmobile and Pontiac Dealers**

**ATTENTION: Service Manager, Parts Manager and Warranty Administrator**

**THIS MESSAGE IS PART 1 OF A 3 PART MESSAGE.**

**IT REPLACES GM ADMINISTRATIVE MESSAGES WIR20040013 AND WIR20040014  
DATED FEBRUARY 23, 2004.**

#### **PRODUCT FIELD ACTION ANNOUNCEMENT**

**General Motors is announcing Product Safety Recall 04002 today. The total number of vehicles involved is 1,047,175. Please see the attached bulletin for complete details.**

**Due to the limitations of the GM Administrative Message System, the bulletin is being sent to you in 3 separate PDF files. Attached below is the 1st file. For the 2nd file see DCS1136 and for the 3rd file see DCS1136.**

**Mailing Information:**

**Customer letter mailing will begin on March 1, 2004 for 1998-1999 model year vehicles.**

**GM Vehicle Inquiry System (GMVIS)**

GMVIS information will be available on February 24, 2004.

**Service Information System (SI)**

Bulletin 04002 is scheduled to be available in SI on March 5, 2004.

**Campaign Initiation Detail Report (CIDR)**

The CIDR will be available in DealerWorld February 23, 2004.

Due to part availability, this recall is being conducted in 3 phases. Phase 1 will consist of 1998 and 1999 model year vehicles; phase 2 will consist of 2000 model year vehicles; and phase 3 will consist of 2001 model year vehicles. When sufficient parts are available to notify owners of 2000 and 2001 model year vehicles, you will be notified and will receive a new initiation report.

**END OF MESSAGE**

**GM SERVICE AND PARTS OPERATIONS**



File In Section: Product Recalls  
Bulletin No.: 04002  
Date: February 2004

# Recall Bulletin



## PRODUCT SAFETY RECALL

**SUBJECT:** IGNITION CIRCUIT THERMAL EVENTS

**MODELS:** 1998 BUICK SKYLARK  
1998-2001 CHEVROLET CAVALIER  
1998 OLDSMOBILE ACHIEVA  
1998 PONTIAC GRAND AM  
1998-2001 PONTIAC SUNFIRE

Due to part availability, this recall is being conducted in three phases. Phase 1 will consist of 1998-1999 vehicles; phase 2 will consist of 2000 vehicles; and phase 3 will consist of 2001 vehicles. When sufficient parts are available to notify customers of 2000 and 2001 vehicles, you will be notified and will receive a new initiation report.

Due to the limitations of the administrative message system, the bulletin is being sent to you in 3 parts.

(PART 1 OF 3)

### CONDITION

General Motors has decided that a defect, which relates to motor vehicle safety, exists in certain 1998 model year Buick Skylark; 1998-2001 model year Chevrolet Cavalier; 1998 model year Oldsmobile Achieva; 1998 model year Pontiac Grand Am; and 1998-2001 model year Pontiac Sunfire vehicles. If the engine fails to start and the driver holds the key in the "start" position for an extended period, high current flows through the ignition switch, and sometimes produces enough heat to melt internal switch parts. If the switch is damaged, a fire could occur in the steering column, even with the engine off and the key removed. The fire could spread to the interior of the car, which could injure occupants of the car or cause damage to adjoining structures.

### CORRECTION

Dealers are to install a relay kit and verify that the vehicle will start with a properly charged battery in good operating condition (adequate reserve capacity, or cold cranking amps).

**VEHICLES INVOLVED**

Involved are certain 1998 model year Buick Skylark; 1998-2001 model year Chevrolet Cavalier; 1998 model year Oldsmobile Achieva; 1998 model year Pontiac Grand Am; and 1998-2001 model year Pontiac Sunfire vehicles built within these VIN breakpoints:

YEAR	DIVISION	MODEL	FROM	THROUGH
1998	Buick	Skylark	WC400001	WC419782
1998	Chevrolet	Cavaller	W7100001	W7338853
			WB900001	WB907093
			WM100001	WM125954
			WS100001	WS195627
			WS800002	WS872036
1999	Chevrolet	Cavaller	X7100001	X7325566
			XB900001	XB907822
			XS100008	XS188987
			XS800001	XS863995
2000	Chevrolet	Cavaller	Y7100001	Y7459760
			YB900001	YB904761
			YS100001	YS257163
2001	Chevrolet	Cavalier	17100001	17370764
			1S100001	1S219421
1998	Oldsmobile	Achieva	WM300001	WM328922
1998	Pontiac	Grand Am	WC700001	WC784311
			WM500001	WM527299
1998	Pontiac	Sunfire	W7500001	W7603242
			WB200001	WB206765
			WS100003	WS195633
			WS800001	WS871999
1999	Pontiac	Sunfire	X7500001	X7586420
			XB200001	XB205488
			XS100009	XS188973
			XS800005	XS863973
2000	Pontiac	Sunfire	Y7100003	Y7459754
			YB200001	YB203598
			YS100011	YS257157
2001	Pontiac	Sunfire	17100002	17370765
			1S100002	1S219425

**IMPORTANT:** Dealers should confirm vehicle eligibility through **GMVIS** (GM Vehicle Inquiry System) prior to beginning recall repairs. [Not all vehicles within the above breakpoints may be involved.]

**For U.S.:** For dealers with involved vehicles, a Campaign Initiation Detail Report containing the complete Vehicle Identification Number, customer name and address data has been prepared and will be loaded to the GM DealerWorld, Recall Information website. The customer name and address data furnished will enable dealers to follow up with customers involved in this recall.

**For Canada & IPC:** Computer listings containing the complete Vehicle Identification Number, customer name and address data of involved vehicles have been prepared, and are being

furnished to involved dealers. The customer name and address data will enable dealers to follow up with customers involved in this recall. Any dealer not receiving a computer listing with the recall bulletin has no involved vehicles currently assigned.

These dealer listings may contain customer names and addresses obtained from Motor Vehicle Registration Records. The use of such motor vehicle registration data for any other purpose is a violation of law in several states/provinces/countries. Accordingly, you are urged to limit the use of this listing to the follow-up necessary to complete this recall.

## PARTS INFORMATION

### Parts Pre-Ship Information - For US and Canada

**Important:** An initial supply of harness kits required to complete this program will be pre-shipped to involved dealers of record. This pre-shipment is equal to 20% of your involved vehicles and is scheduled to begin the week of February 16, 2004. Pre-shipped parts will be charged to dealer's open parts account.

Additional parts, if required, are to be obtained from General Motors Service Parts Operations (GMSPO). Please refer to your "involved vehicles listing" before ordering parts. Normal orders should be placed on a DRO = Daily Replenishment Order. In an emergency situation, parts should be ordered on a CSO = Customer Special Order.

Part Number	Description	Quantity/ Vehicle
22694036	Harness Kit, Engine Wiring Harness Extension (4 Cyl. J Car and N Car)	1
88880045	Harness Kit, Engine Wiring Harness Extension (8 Cyl. N Car)	1
26034119	Switch, Ignition (All)	As Required
22551357	Lever, Steering Column Tilt Wheel Release (All)	As Required
12089191	Splice Sleeve (Sealed)	As Required
25010633 - U.S. 729854 - Canada	Filter, Engine Oil (PF44) - 4 Cylinder (1998 2.4L Only)	1

## SERVICE PROCEDURE

1. Open the hood.
2. Check the battery state of health using J 4200 Midtronics Digital Battery Tester or suitable equivalent. If the tester displays "Replace Battery", attach a battery charger to the battery while performing this repair, as the test at the end will require cranking/starting the engine six times in succession. A low battery state of charge may affect the outcome of the test.

### **Important**

If the battery fails the test (does not have sufficient reserve capacity or cold cranking amps required), the customer should be advised that the battery is not functioning properly and should be replaced. The customer should be informed that battery replacement is not covered under this recall, and that a replacement battery may be purchased from the dealership or another source.

3. Disconnect the negative battery cable.

**Caution**

The oil filter, exhaust manifold, and exhaust pipe may be hot. Use care to avoid personal injury.

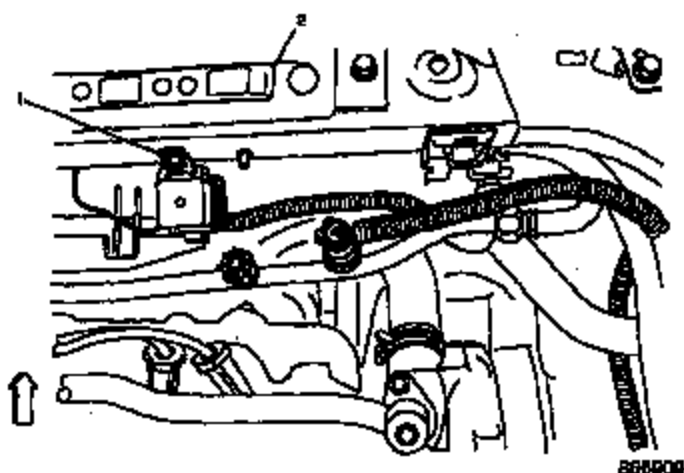
**1998 N car - Achieva/Grand Am/Skylark with 3.1L V6 Engine (VIN Code M)**

1. Locate the round hole located in the small depressed area in the back side of the radiator support upper bar just to the right (passenger side) of the air bag sensor mounting bracket and install the J-nut included in the harness kit.
2. Attach the relay bracket (1) on the harness kit to the radiator tie bar (2) using the J-nut previously installed and the shorter hex head bolt (with the washer) included in the kit. **Tighten**

Tighten the bolt to 10 N·m (89 lb in).

3. Locate the short black wire with a ring terminal on one end from the harness kit.
4. Using the longer hex head bolt (without the washer) included in the kit, attach the ring terminal to the weld nut located on the top surface of the upper radiator support bar just to the left (driver side) of the air bag support bracket. **Tighten**

Tighten to 10 N·m (89 lb in).

5. Route the new wiring harness down to the starter motor. On vehicles with automatic transmissions, fasten the harness to the cooler lines using the clips on the harness.
6. Raise the vehicle on a suitable hoist.
7. Remove the nut from the starter solenoid "B" terminal, and remove all wires and the positive battery cable from the terminal.

8. Visually inspect the condition of the "S" terminal stud and nut on the starter solenoid.
  - o If the nut and/or stud appear to be in good condition with little or no sign of corrosion, proceed to Step 16 and remove the nut. Do NOT perform Steps 9-15 if the stud and nut are in good condition.
  - o If the nut and/or stud appear to be corroded to the point where the stud may break off if removal of the nut is attempted, proceed to Step 9 of this procedure. Steps 9-15 will require the use of one ADDITIONAL butt connector P/N 12089191. Obtain the additional butt connector before proceeding.
9. Using wire cutters, cut the purple wire off the "S" terminal of the starter solenoid leaving approximately 50mm (2 in) of wire on the terminal.
10. Strip the insulation back about 6.35 mm (1/4 in) on the short purple wire that remained on the starter solenoid.
11. Using an appropriate crimping tool, install one end of butt connector P/N 12089191 on the short purple wire.
12. Using wire cutters, cut the small ring terminal off the end of the red wire on the service harness kit.
13. Strip the insulation back about 6.35 mm (1/4 in) on the red wire.
14. Using an appropriate crimping tool, install the red wire in the other end of the butt connector that is on the starter solenoid short purple wire.
15. Using an appropriate tool, heat shrink the yellow tubing on the butt connector to shrink it into position to seal the connection.

#### **Important**

If you have just completed Steps 9-15, proceed to Step 18. Do not perform Steps 16-17. If you did NOT perform Steps 9-15, proceed to Step 16.

16. Remove the nut from the starter solenoid "S" terminal, and remove all wires from the solenoid terminal.
17. Cut the ring terminal from the vehicle wiring harness purple wire which was removed from the "S" terminal.
18. Strip the insulation back about 6.35 mm (1/4 in) on the purple wires of the vehicle wiring harness and the service harness kit.
19. Using an appropriate crimping tool, install one end of the butt connector included in the harness kit on the purple wire.
20. Install and crimp the other end of the butt connector, which is already installed on the harness kit, on the purple wire on the vehicle's wiring harness. Crimp the wires together firmly.
21. Using an appropriate tool, heat shrink the yellow tubing on the butt connector to shrink it into position to seal the connection.

#### **Important**

If you performed Steps 9-15 earlier, proceed to the next IMPORTANT statement prior to Step 24. Do not perform Steps 22-23. If you did NOT perform Steps 9-15 earlier, proceed to Step 22.

22. Thoroughly clean the interface surfaces of the "S" terminal. Ensure the "S" terminal is snug to the starter solenoid cap.

23. Install the small ring terminal on the red wire of the service harness kit and install it on the "S" terminal. Reinstall the nut. **Tighten**

Tighten the nut to 2.5 N·m (22 lb in).

**Important**

In the next step, make sure the battery cable is the last cable positioned on the starter solenoid "B" terminal so that the nut is tightened against the battery cable.

24. Thoroughly clean the interface surfaces of the "B" terminal on the starter solenoid.
25. Clean the fusible link terminal on the vehicle wiring harness and install it on the starter solenoid "B" terminal.
26. Install the large ring terminal on the harness kit on the starter solenoid "B" terminal.
27. Clean and install the positive battery cable on the starter solenoid "B" terminal. Install the nut. **Tighten**

Tighten the nut to 11 N·m (97 lb in).

28. Lower the vehicle.
29. Reinstall the negative battery cable to the battery. **Tighten**

Tighten the bolt to 16 N·m (12 lb ft).

**Important**

Do not use a remote starter device in the next step. The vehicle ignition switch must be used to start the vehicle (turn ignition switch to crank position) to verify that the ignition switch is in good working condition.

30. Using the ignition key, start the engine and allow it to run approximately 5 seconds. After 5 seconds, turn the engine off for approximately 5 seconds. Repeat this 6 times.
  - o If the starter cranks the engine 6 times in a row, no further action is required.
  - o If the starter will NOT crank the engine, skip to **Procedure A** for N car **Achieva/Grand Am/Skylark**.

**1996 N car - Achieva/Grand Am/Skylark with 2.4L Engine (VIN Code T)**

1. Remove the two 10mm hex head bolts that secure the air cleaner outlet resonator to the throttle body.
2. Disconnect the electrical connector from the sensor in the air cleaner outlet duct.
3. Loosen the clamp that secures the air cleaner outlet duct to the air cleaner housing.
4. Loosen the clamp that secures the air cleaner outlet resonator to the throttle body.
5. Remove the air cleaner outlet duct and the air cleaner outlet resonator from the throttle body.



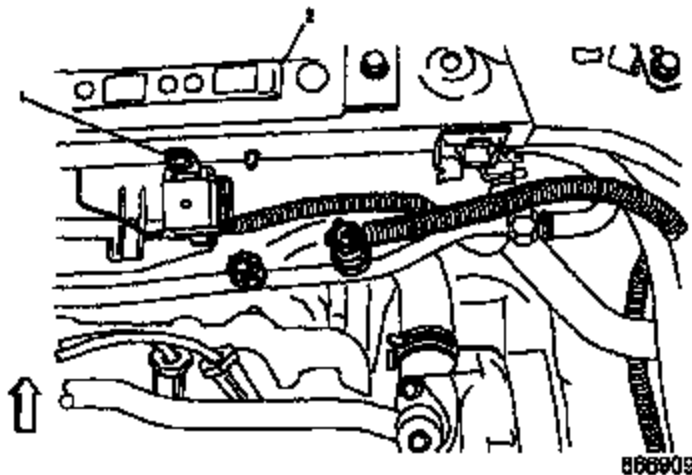

6. Locate the round hole located in the small depressed area in the back side of the radiator support upper bar just to the right (passenger side) of the air bag sensor mounting bracket and install the J-nut included in the harness kit.
7. Attach the relay bracket (1) on the harness kit to the radiator tie bar (2) using the J-nut previously installed and hex head bolt included in the kit. Tighten

Tighten the screw to 10 N-m (89 lb in).

8. On the HARNESS KIT, strip the insulation back about 6.35 mm (1/4 in) on the purple wire. The purple wire is the only wire on the harness kit that does not have a terminal on it.
9. Using an appropriate crimping tool, install one end of the butt connector included in the harness kit on the purple wire.
10. Route the new wiring harness down to the starter motor.
11. Remove the top starter bolt.
12. Raise the vehicle on a suitable hoist.
13. Remove the oil filter.
14. On 1986 models, remove the two bolts that attach the intake manifold brace to the engine block and the two bolts that attach it to the intake manifold. Remove that brace.
15. Remove the bottom starter bolt and remove the starter.
16. Remove the nut from the "B" terminal of the starter and disconnect all wires and the positive battery cable from the terminal.
17. Visually inspect the condition of the "S" terminal stud and nut on the starter solenoid.
  - o If the nut and/or stud appear to be in good condition with little or no sign of corrosion, proceed to Step 25 and remove the nut. Do NOT perform Steps 18-24 if the stud and nut are in good condition.
  - o If the nut and/or stud appear to be corroded to the point where the stud may break off if removal of the nut is attempted, proceed to Step 18 of this procedure. Steps 18-20 will require the use of one ADDITIONAL butt connector P/N 12089191. Obtain the additional butt connector before proceeding.
18. Using wire cutters, cut the purple wire off the "S" terminal of the starter solenoid leaving approximately 50mm (2 in) of wire on the terminal.
19. Strip the insulation back about 6.35 mm (1/4 in) on the short purple wire that remained on the starter solenoid.
20. Using an appropriate crimping tool, install one end of butt connector P/N 12089191 on the short purple wire.

21. Using wire cutters, cut the small ring terminal off the end of the red wire on the service harness kit.
22. Strip back the insulation back about 6.35 mm (1/4 in) on the red wire.
23. Using an appropriate crimping tool, install the red wire in the other end of the butt connector that is on the starter solenoid short purple wire.
24. Using an appropriate tool, heat shrink the yellow tubing on the butt connector to shrink it into position to seal the connection.

**Important**

If you have just completed Steps 18-24, proceed to Step 27. Do NOT perform Steps 25-26. If you did NOT perform Steps 18-24, proceed to Step 25.

25. Remove the nut from the starter solenoid "S" terminal, and remove all the wires from the terminal.
26. Cut the ring terminal from the vehicle wiring harness purple wire which was removed from the "S" terminal.
27. Strip the insulation back about 6.35 mm (1/4 in) on the purple wire of the vehicle wiring harness.
28. Using an appropriate crimping tool, install the other end of the butt connector, which is already installed on the harness kit, on the purple wire on the vehicle's wiring harness. Crimp the wires together firmly.
29. Using an appropriate tool, heat shrink the yellow tubing on the butt connector to shrink it into position to seal the connection.

**Important**

If you performed Steps 18-24 earlier, proceed to the next IMPORTANT statement prior to Step 32. Do not perform Steps 30-31. If you did NOT perform Steps 18-24 earlier, proceed to Step 30.

30. Thoroughly clean the interface surfaces of the "S" terminal. Ensure that the "S" terminal is snug to the starter solenoid cap.
31. Install the small ring terminal on the red wire of the service harness kit and install it on the "S" terminal. Reinstall the nut. **Tighten**

Tighten the nut to 2.5 N·m (22 lb in).

**important**

In the next steps, make sure the battery cable is the last cable positioned on the starter solenoid "B" terminal so that the nut is tightened against the battery cable.

32. Thoroughly clean the interface surfaces of the "B" terminal on the starter solenoid.
33. Clean the fusible link terminal on the vehicle wiring harness and install it on the starter solenoid "B" terminal.
34. Install the large ring terminal on the harness kit on the starter solenoid "B" terminal.
35. Clean and install the positive battery cable on the starter solenoid "B" terminal. Install the nut. **Tighten**

Tighten to 11 N·m (97 lb in).

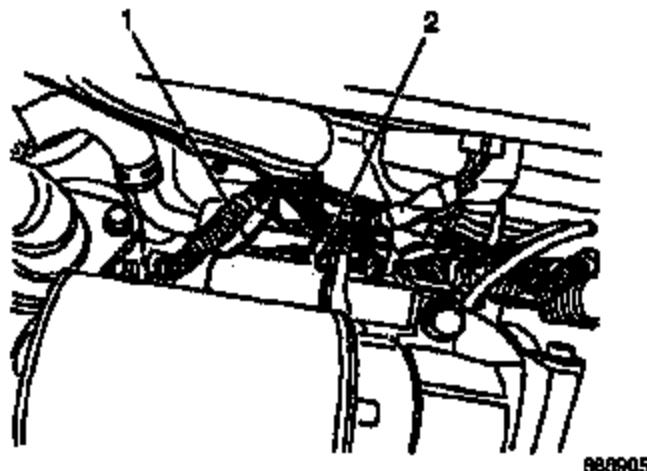

36. Remove one of the bolts (2) that attach the starter solenoid (1) to the starter motor.
37. Install the ground ring terminal (black wire) on the harness kit on the bolt and reinstall it in the starter. **Tighten**

Tighten to 9 N·m (80 lb in).

38. Install the starter to the engine and install the lower bolt finger tight. Do not tighten at this time.
39. Lower the vehicle.
40. Install the upper starter bolt. **Tighten**

Tighten the bolt to 90 N·m (66 lb ft).

41. Raise the vehicle.
42. Tighten the lower starter bolt. **Tighten**

Tighten the bolt to 90 N·m (66 lb ft).

43. On 1996 models, install the intake manifold brace to the engine block and install the two bolts finger tight. Install the two bolts attaching the brace to the intake manifold. **Tighten**
- o Tighten the two bolts attaching the brace to the intake manifold to 24 N·m (18 lb ft).
  - o Tighten the two bolts to the engine block to 26 N·m (19 lb ft).

44. Install a new oil filter.
45. Lower the vehicle.
46. Remove the rubber seal from around the top of the throttle body and install it on the bottom of the air cleaner outlet resonator.
47. Position the air cleaner outlet duct and resonator over the throttle body and install the hose to the bottom of the resonator.
48. Install the air cleaner outlet resonator on the throttle body. **Tighten**

Tighten the clamp to 5 N·m (44 lb in).

**49. Connect the air cleaner outlet duct to the air cleaner housing. Tighten**

Tighten the clamp to 5 N·m (44 lb in).

**50. Connect the electrical connector to the sensor in the air cleaner outlet duct.****51. Install the two 10 mm hex head bolts that secure the air cleaner outlet resonator. Tighten**

Tighten the bolts to 10 N·m (89 lb in).

**52. Reinstall the negative battery cable to the battery. Tighten**

Tighten the bolt to 16 N·m (12 lb ft).

**Important**

Do not use a remote starter device in the next step. The vehicle ignition switch must be used to start the vehicle (turn ignition switch to crank position) to verify that the ignition switch is in good working condition.

**53. Using the ignition key, start the engine and allow it to run approximately 5 seconds. After 5 seconds, turn the engine off for approximately 5 seconds. Repeat this 6 times.**

- o If the starter cranks the engine 6 times in a row, proceed to the next step.
- o If the starter will NOT crank the engine, skip to **Procedure A** for **Achieva/Grand Am/Skylark**

**54. Check the engine oil level and add as necessary.****1998 N car - Achieva/Grand Am/Skylark -- PROCEDURE A (all engines)**

1. Remove the fuse panel trim plate from the Instrument Panel (I/P) and remove the 15-amp AIR BAG fuse.
2. Remove the left side dash lower insulation panel.
3. Remove the Connector Position Assurance (CPA) from the yellow air bag connector located at the base of the steering column and disconnect the connector.
4. Remove the left side knee bolster trim panel.
5. If equipped, remove the tilt steering column lever.
6. Remove the bezel around the key lock cylinder.
7. Remove the screws that hold the steering column trim in place.
8. Remove both halves of the steering column trim.
9. Disconnect the wiring from the ignition switch.

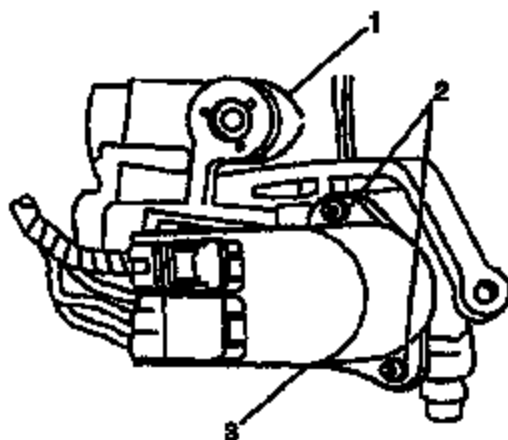

800922

10. Remove the two screws (2) holding the ignition switch (3) to the steering column (1). Remove the ignition switch from the steering column.

**Notice**

The ignition switch mounting screws and the screws that secure the upper and lower halves of the steering column covers are self-tapping. To prevent stripping the screws when attaching the ignition switch and steering column covers, the following procedure should be used:

- o Place the screw into position and with slight pressure, rotate the screw in a counter-clockwise (loosening) direction.
  - o When the original thread is located, the screw will drop slightly; reverse direction and tighten the screw.
11. Position the new ignition switch to the column and check for proper location of the tab. Install both screws. **Tighten**  
  
Tighten both screws to 1.4 N·m (12 lb in).
  12. Attach the wiring harness connectors to the ignition switch.
  13. Reinstall the upper and lower steering column covers. **Tighten**  
  
Tighten the fasteners to 9 N·m (80 lb in).
  14. Reinstall the knee bolster trim. **Tighten**  
  
Tighten the fasteners to 2 N·m (18 lb in).
  15. Reconnect the yellow airbag connector at the base of the steering column and install the CPA.
  16. Reinstall the sound insulator panel. **Tighten**  
  
Tighten the fasteners to 2 N·m (18 lb in).
  17. Reinstall the 15-amp AIR BAG fuse into the fuse box and replace the VP trim cover.
  18. Turn the ignition switch to the ON position and verify that the AIR BAG indicator light flashes seven times and goes out.

**(PROCEED TO PART 2)**

**Dealer TO: ALL BUICK, CHEVROLET, OLDSMOBILE AND PONTIAC DEALERS**  
**Salutation: ATTENTION: SERVICE MANAGER, PARTS MANAGER AND WARRANTY ADMINISTRATOR**

**GM SERVICE AND PARTS OPERATIONS**  
**DCS1138**  
**URGENT DISTRIBUTE IMMEDIATELY**

**DATE: February 24, 2004**

**SUBJECT: 04002 / Product Safety Recall Ignition Circuit Thermal Events**

**MODELS: 1998 Buick Skylark**  
**1998-2001 Chevrolet Cavalier**  
**1998 Oldsmobile Achieva**  
**1998 Pontiac Grand Am**  
**1998-2001 Pontiac Sunfire**

**TO: All Buick, Chevrolet, Oldsmobile and Pontiac Dealers**

**ATTENTION: Service Manager, Parts Manager and Warranty Administrator**

**THIS MESSAGE IS PART 2 OF A 3 PART MESSAGE.**  
**IT REPLACES GM ADMINISTRATIVE MESSAGES WIR20040013 AND WIR20040014**  
**DATED FEBRUARY 23, 2004.**

**PRODUCT FIELD ACTION ANNOUNCEMENT**

**General Motors is announcing Product Safety Recall 04002 today. The total number of vehicles involved is 1,047,175. Please see the attached bulletin for complete details.**

**Due to the limitations of the GM Administrative Message System, the bulletin is being sent to you in 3 separate PDF files. Attached below is the 2nd file. For the 1st file see DCS1135 and for the 3rd file see DCS1138.**

**Mailing Information**

**Customer letter mailing will begin on March 1, 2004 for 1998-1999 model year vehicles.**

**GM Vehicle Inquiry System (GMVIS)**

**GMVIS information will be available on February 24, 2004.**

**Service Information System (SI)**

Bulletin 04002 is scheduled to be available in SI on March 5, 2004.

**Campaign Initiation Detail Report (CIDR)**

The CIDR will be available in DealerWorld February 23, 2004.

Due to part availability, this recall is being conducted in 3 phases. Phase 1 will consist of 1998 and 1999 model year vehicles; phase 2 will consist of 2000 model year vehicles; and phase 3 will consist of 2001 model year vehicles. When sufficient parts are available to notify owners of 2000 and 2001 model year vehicles, you will be notified and will receive a new Initiation report.

**END OF MESSAGE**

**GM SERVICE AND PARTS OPERATIONS**

**(PART 2 OF 3)****1998 J car - Cavalier/Sunfire with 2.4L Engine (VIN Code T)**

1. Remove the two 10 mm hex head bolts that secure the air cleaner outlet resonator to the throttle body.
2. Disconnect the electrical connector from the sensor in the air cleaner outlet duct.
3. Loosen the clamp that secures the air cleaner outlet duct to the air cleaner housing.
4. Loosen the clamp that secures the air cleaner outlet resonator to the throttle body.
5. Remove the air cleaner outlet duct and the air cleaner outlet resonator from the throttle body.

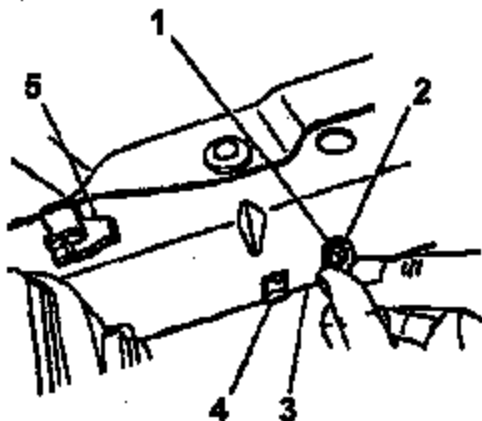

1423721

6. Slide the J-nut (1) included in the harness kit on the bottom edge of the upper radiator support (3) so that it is located just to the right of the existing clip (4). If there is no clip, use the prop rod holding clip (5) as a reference for determining the correct location for the J-nut.
7. With the J-nut in position, use a pencil to mark the location (2) for a 6.35 mm (1/4 in) to be drilled.

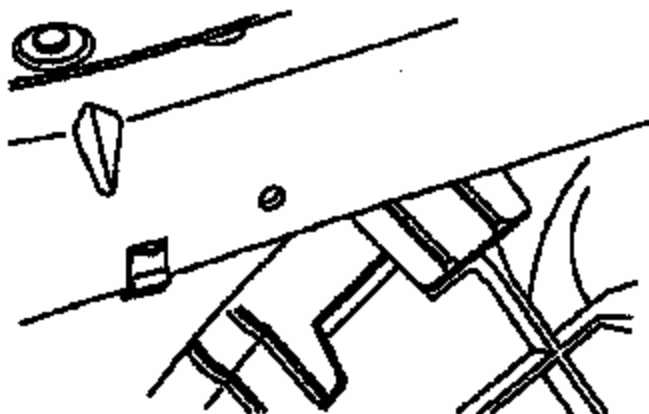

068849

8. Remove the J-nut and using a 6.35 mm (1/4 in) drill bit, drill a hole in the radiator support at the location marked (2) in the previous step. The above illustration shows the radiator support after the hole has been drilled.
9. Touch up the drilled hole as necessary using an appropriate anti-corrosion material.



10. On the HARNESS KIT, strip the insulation back about 6.35 mm (1/4 in) on the purple wire. The purple wire is the only wire on the harness kit that does not have a terminal on it.
11. Using an appropriate crimping tool, install one end of the butt connector, included in the harness kit, on the purple wire.
12. Slide the J-nut on the bottom edge of the radiator support and over the drilled hole.

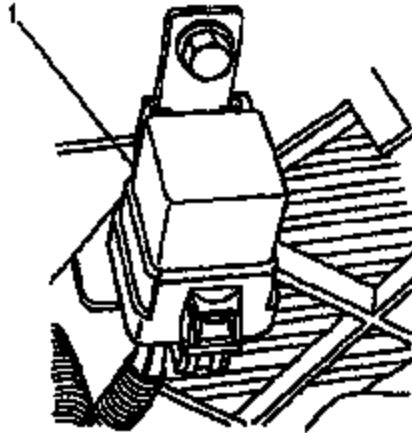

88854

13. Using the 10 mm hex head bolt provided in the harness kit, attach the relay (1) to the radiator support using the previously drilled hole and J-nut. **Tighten**

Tighten the bolt to 10 N-m (89 lb in).

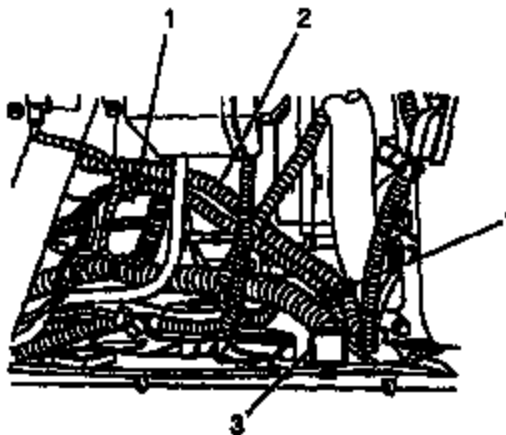

858432

### Important

The push-in barbed feature on the plastic harness clips are NOT used when attaching the wiring harnesses together in the next step.

14. Route and attach the service relay harness (3) to the vehicle wiring harness (2) using the two plastic clips (1) already attached to the relay harness.
15. Remove the top starter bolt.
16. Raise the vehicle on a suitable hoist.
17. Remove the oil filter.
18. Remove the bottom starter bolt and remove the starter.

19. Remove the nut from the "B" terminal of the starter and disconnect all wires and the positive battery cable from the terminal.
20. Visually inspect the condition of the "S" terminal stud and nut on the starter solenoid.
  - o If the nut and/or stud appear to be in good condition with little or no sign of corrosion, proceed to Step 28 and remove the nut. Do NOT perform Steps 21-27 if the stud and nut are in good condition.
  - o If the nut and/or stud appear to be corroded to the point where the stud may break off if removal of the nut is attempted, proceed to Step 21 of this procedure. Steps 21-27 will require the use of one ADDITIONAL butt connector, P/N 12089191. Obtain the additional butt connector before proceeding.
21. Using wire cutters, cut the purple wire off the "S" terminal of the starter solenoid leaving approximately 50 mm (2 in) of wire on the terminal.
22. Strip the insulation back about 6.35 mm (1/4 in) on the short purple wire that remained on the starter solenoid.
23. Using an appropriate crimping tool, install one end of butt connector, P/N 12089191 on the short purple wire.
24. Using wire cutters, cut the small ring terminal off the end of the red wire on the service harness kit.
25. Strip the insulation back about 6.35 mm (1/4 in) on the red wire.
26. Using an appropriate crimping tool, install the red wire in the other end of the butt connector that is on the starter solenoid short purple wire.
27. Using an appropriate tool, heat shrink the yellow tubing on the butt connector to shrink it into position to seal the connection.

#### **Important**

If you have just completed Steps 21-27, proceed to Step 30. Do NOT perform Steps 28-29. If you did NOT perform Steps 21-27, proceed to Step 28.

28. Remove the nut from the starter solenoid "S" terminal, and remove all the wires from the terminal.
29. Cut the ring terminal from the vehicle wiring harness purple wire, which was removed from the "S" terminal.
30. Strip the insulation back about 6.35 mm (1/4 in) on the purple wires of the vehicle wiring harness and the service harness kit.
31. Using an appropriate crimping tool, install the other end of the butt connector, which is already installed on the harness kit, on the purple wire on the vehicle's wiring harness. Crimp the wires together firmly.
32. Using an appropriate tool, heat shrink the yellow tubing on the butt connector to shrink it into position to seal the connection.

#### **Important**

If you performed Steps 21-27 earlier, proceed to the next IMPORTANT statement prior to Step 35. Do not perform Steps 33-34. If you did NOT perform Steps 21-27 earlier, proceed to Step 33.

33. Thoroughly clean the interface surfaces of the "S" terminal. Ensure the "S" terminal is snug to the starter solenoid cap.

34. Install the small ring terminal on the red wire of the service harness kit and install it on the "S" terminal. Reinstall the nut. **Tighten**

Tighten the nut to 2.5 N·m (22 lb in).

#### **Important**

In the next step, make sure the battery cable is the last cable positioned on the starter solenoid "B" terminal so that the nut is tightened against the battery cable.

35. Thoroughly clean the interface surfaces of the "B" terminal on the starter solenoid.  
36. Clean the fusible link terminal on the vehicle wiring harness and install it on the starter solenoid "B" terminal.  
37. Install the large ring terminal on the harness kit on the starter solenoid "B" terminal.  
38. Clean and install the positive battery cable on the starter solenoid "B" terminal. Install the nut. **Tighten**

Tighten the nut to 11 N·m (97 lb in).

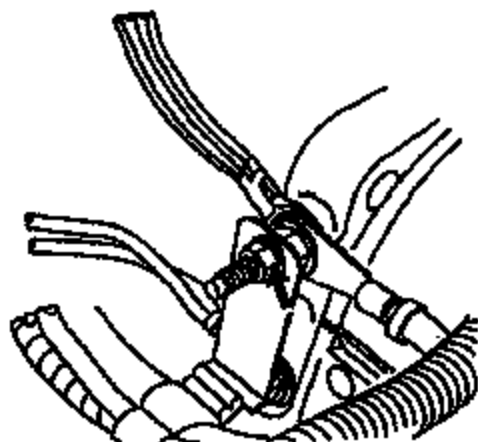

620365

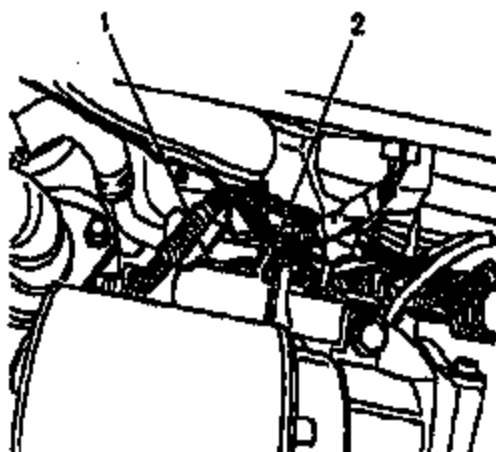

866905

39. If equipped, remove the 10 mm hex head nut from the ground stud on the engine block. If no ground stud is present, remove one of the bolts (2) that attach the starter solenoid (1) to the starter motor.

40. Install the ground ring terminal (black wire) on the harness kit on the ground stud or solenoid bolt. Install the nut on the stud. **Tighten**

Tighten the bolt to 9 N-m (80 lb in).

41. Install the starter to the engine and install the lower bolt finger tight. Do not tighten at this time.  
42. Lower the vehicle.  
43. Install the upper starter bolt. **Tighten**

Tighten the bolt to 90 N-m (66 lb ft).

44. Raise the vehicle.  
45. Tighten the lower starter bolt. **Tighten**

Tighten the bolt to 90 N-m (66 lb ft).

46. Install a new oil filter.  
47. Lower the vehicle.  
48. Remove the rubber seal from around the top of the throttle body and install it on the bottom of the air cleaner outlet resonator.  
49. Position the air cleaner outlet duct and resonator over the throttle body and install the hose to the bottom of the resonator.  
50. Install the air cleaner outlet resonator on the throttle body. **Tighten**

Tighten the clamp to 5 N-m (44 lb in).

51. Connect the air cleaner outlet duct to the air cleaner housing. **Tighten**

Tighten the clamp to 5 N-m (44 lb in).

52. Connect the electrical connector to the sensor in the air cleaner outlet duct.  
53. Install the two 10 mm hex head bolts that secure the air cleaner outlet resonator. **Tighten**

Tighten the bolts to 10 N-m (89 lb in).

54. Reinstall the negative battery cable to the battery. **Tighten**

Tighten the bolt to 16 N-m (12 lb ft).

#### **Important**

Do not use a remote starter device in the next step. The vehicle ignition switch must be used to start the vehicle (turn ignition switch to crank position) to verify that the ignition switch is in good working condition.

55. Using the ignition key, start the engine and allow it to run approximately 5 seconds. After 5 seconds, turn the engine off for approximately 5 seconds. Repeat this 6 times.
- o If the starter cranks the engine 6 times in a row, proceed to the next step.
  - o If the starter will NOT crank the engine, skip to Procedure A for J car Cavalier/Sunfire.

56. Check the engine oil level and add as necessary.

**1999-2001 J car - Cavalier/Sunfire with 2.4L Engine (VIN Code T)**

1. Remove the two 10 mm hex head bolts that secure the air cleaner outlet resonator to the throttle body.
2. Disconnect the electrical connector from the sensor in the air cleaner outlet duct.
3. Loosen the clamp that secures the air cleaner outlet duct to the air cleaner housing.
4. Loosen the clamp that secures the air cleaner outlet resonator to the throttle body.
5. Remove the air cleaner outlet duct and the air cleaner outlet resonator from the throttle body.

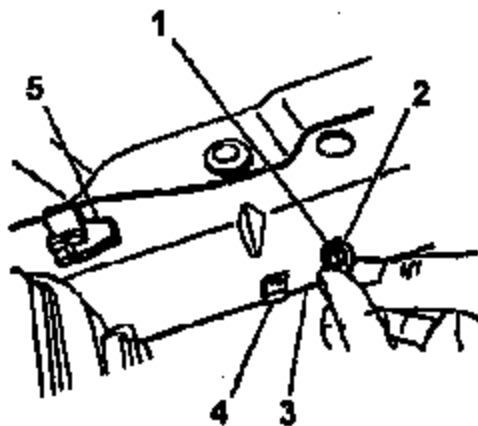

1423721

6. Slide the J-nut (1) included in the harness kit on the bottom edge of the upper radiator support (3) so that it is located just to the right of the existing clip (4). If there is not clip, use the prop rod holding clip (5) as a reference for determining the correct location for the J-nut.
7. With the J-nut in position, use a pencil to mark the location (2) for a 6.35 mm hole (1/4 in) to be drilled.

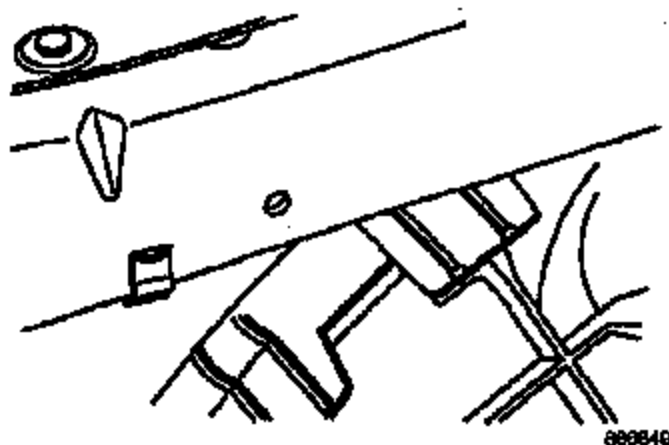

898846

8. Remove the J-nut and using a 6.35 mm (1/4 in) drill bit, drill a hole in the radiator support at the location marked (2) in the previous step. The above illustration shows the radiator support after the hole has been drilled.

9. Touch up the drilled hole as necessary using an appropriate anti-corrosion material.
10. On the HARNESS KIT, strip the insulation back about 6.35 mm (1/4 in) on the purple wire. The purple wire is the only wire on the harness kit that does not have a terminal on it.
11. Using an appropriate crimping tool, install one end of the butt connector included in the harness kit on the purple wire.
12. Slide the J-nut on the bottom edge of the radiator support and over the drilled hole.

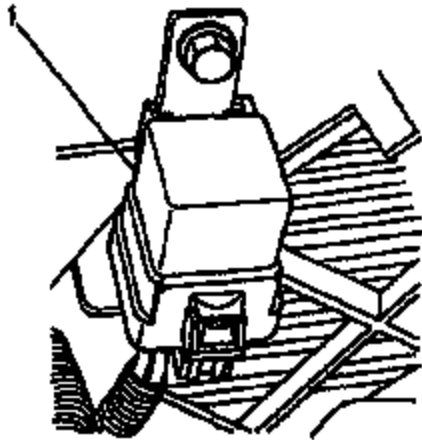

686854

13. Using the 10 mm hex head bolt provided in the harness kit, attach the relay (1) to the radiator support using the previously drilled hole and J-nut. **Tighten**

Tighten the bolt to 10 N-m (89 lb in).

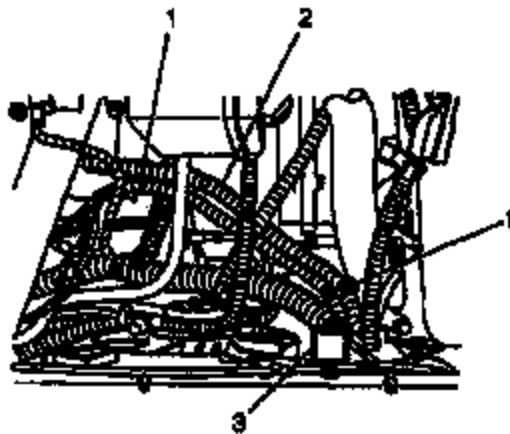

659432

### Important

The push-in barbed feature on the plastic harness clips are **NOT** used when attaching the wiring harnesses together in the next step.

14. Route and attach the service relay harness (3) to the vehicle wiring harness (2) using the two plastic clips (1) already attached to the relay harness.

**Important**

The terminals located on the starter motor solenoid can be accessed through the opening between the runners in the intake manifold. It is not necessary to remove the starter motor to access the terminals on the 1999-2001 models.

15. Remove the nut from the "B" terminal of the starter and disconnect all wires and the positive battery cable from the terminal.
16. Visually inspect the condition of the "S" terminal stud and nut on the starter solenoid.
  - o If the nut and/or stud appear to be in good condition with little or no sign of corrosion, proceed to Step 24 and remove the nut. Do NOT perform Steps 17-23 if the stud and nut are in good condition.
  - o If the nut and/or stud appear to be corroded to the point where the stud may break off if removal of the nut is attempted, proceed to Step 17 of this procedure. Steps 17-23 will require the use of one ADDITIONAL butt connector, P/N 12089191. Obtain the additional butt connector before proceeding.
17. Using wire cutters, cut the purple wire off the "S" terminal of the starter solenoid leaving approximately 50 mm (2 in) of wire on the terminal.
18. Strip the insulation back about 6.35 mm (1/4 in) on the short purple wire that remained on the starter solenoid.
19. Using an appropriate crimping tool, install one end of butt connector, P/N 12089191 on the short purple wire.
20. Using wire cutters, cut the small ring terminal off the end of the red wire on the service harness kit.
21. Strip the insulation back about 6.35 mm (1/4 in) on the red wire.
22. Using an appropriate crimping tool, install the red wire in the other end of the butt connector that is on the starter solenoid short purple wire.
23. Using an appropriate tool, heat shrink the yellow tubing on the butt connector to shrink it into position to seal the connection.

**Important**

If you have just completed Steps 17-23, proceed to Step 26. Do not perform Steps 24-25. If you did NOT perform Steps 17-23, proceed to Step 24.

24. Remove the nut from the starter solenoid "S" terminal, and remove all the wires from the terminal.
25. Cut the ring terminal from the vehicle wiring harness purple wire, which was removed from the "S" terminal.
26. Strip the insulation back about 6.35 mm (1/4 in) on the purple wires of the vehicle wiring harness and the service harness kit.
27. Using an appropriate crimping tool, install the other end of the butt connector, which is already installed on the harness kit, on the purple wire on the vehicle's wiring harness. Crimp the wires together firmly.
28. Using an appropriate tool, heat shrink the yellow tubing on the butt connector to shrink it into position to seal the connection.

**Important**

If you performed Steps 17-23 earlier, proceed to the next IMPORTANT statement prior to Step 31. Do not perform Steps 29-30. If you did NOT perform Steps 17-23 earlier, proceed to Step 29.

29. Thoroughly clean the interface surfaces of the "S" terminal. Ensure the "S" terminal is snug to the starter solenoid cap.

**Important**

Because access to the "S" terminal and the "B" terminal on the starter solenoid is limited, it may not be possible to use a torque wrench when tightening the terminal attaching nuts in upcoming Steps 30 and 34. If your torque wrench cannot be used because of insufficient clearance, it is acceptable to tighten the nuts "securely" using regular hand tools.

30. Install the small ring terminal on the red wire of the service harness kit and install it on the "S" terminal. Reinstall the nut. **Tighten**

Tighten the nut to 2.5 N·m (22 lb in).

**Important**

In the next step, make sure the battery cable is the last cable positioned on the starter solenoid "B" terminal so that the nut is tightened against the battery cable.

31. Thoroughly clean the interface surfaces of the "B" terminal on the starter solenoid.
32. Clean the fusible link terminal on the vehicle wiring harness and install it on the starter solenoid "B" terminal.
33. Install the large ring terminal on the harness kit on the starter solenoid "B" terminal.
34. Clean and install the positive battery cable on the starter solenoid "B" terminal. Install the nut. **Tighten**

Tighten the nut to 11 N·m (97 lb in).



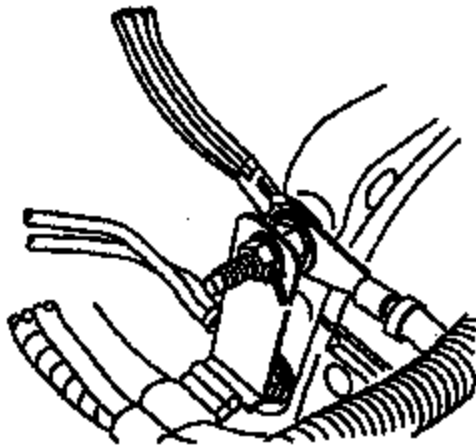

820985

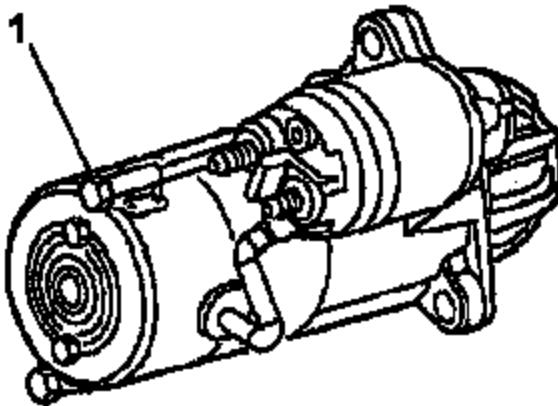

1428877

35. If equipped, remove the 10 mm hex head nut from the ground stud on the engine block. If no ground stud is present, remove one of the long bolts (1) that hold the starter motor end cap to the housing.
36. Install the ground ring terminal (black wire) on the harness kit on the ground stud or on the long bolt on the starter motor. Install the nut on the stud or install the long bolt in the starter. **Tighten**
  - o Tighten the nut to 18 N·m (13 lb ft).
  - o Tighten the long bolt to 9 N·m (80 lb in).
37. Remove the rubber seal from around the top of the throttle body and install it on the bottom of the air cleaner outlet resonator.
38. Position the air cleaner outlet duct and resonator over the throttle body and install the hose to the bottom of the resonator.
39. Install the air cleaner outlet resonator on the throttle body. **Tighten**

Tighten the clamp to 5 N·m (44 lb in).

40. Connect the air cleaner outlet duct to the air cleaner housing. **Tighten**

Tighten the clamp to 5 N·m (44 lb in).

41. Connect the electrical connector to the sensor in the air cleaner outlet duct.

42. Install the two 10 mm hex head bolts that secure the air cleaner outlet resonator. **Tighten**

Tighten the bolts to 10 N·m (89 lb in).

43. Reinstall the negative battery cable to the battery. **Tighten**

Tighten the bolt to 16 N·m (12 lb ft).

#### **Important**

Do not use a remote starter device in the next step. The vehicle ignition switch must be used to start the vehicle (turn ignition switch to crank position) to verify that the ignition switch is in good working condition.

44. Using the ignition key, start the engine and allow it to run approximately 5 seconds. After 5 seconds, turn the engine off for approximately 5 seconds. Repeat this 6 times.
- o If the starter cranks the engine 6 times in a row, no further action is required.
  - o If the starter will NOT crank the engine, skip to **Procedure A** for **J car Cavalier/Sunfire**.

**(PROCEED TO PART 3)**

Dealer TO: ALL BUICK, CHEVROLET, OLDSMOBILE AND PONTIAC DEALERS  
Salutation: ATTENTION: SERVICE MANAGER, PARTS MANAGER AND WARRANTY ADMINISTRATOR

**GM SERVICE AND PARTS OPERATIONS  
DCS1138  
URGENT DISTRIBUTE IMMEDIATELY**

**DATE:** February 24, 2004

**SUBJECT:** 04002 / Product Safety Recall  
Ignition Circuit Thermal Events

**MODELS:** 1998 Buick Skylark  
1998-2001 Chevrolet Cavalier  
1998 Oldsmobile Achieva  
1998 Pontiac Grand Am  
1998-2001 Pontiac Sunfire

**TO:** All Buick, Chevrolet, Oldsmobile and Pontiac Dealers

**ATTENTION:** Service Manager, Parts Manager and Warranty Administrator

**THIS MESSAGE IS PART 3 OF A 3 PART MESSAGE.  
IT REPLACES GM ADMINISTRATIVE MESSAGES WIR20040013 AND WIR20040014  
DATED FEBRUARY 23, 2004.**

**PRODUCT FIELD ACTION ANNOUNCEMENT**

General Motors is announcing Product Safety Recall 04002 today. The total number of vehicles involved is 1,047,175. Please see the attached bulletin for complete details.

Due to the limitations of the GM Administrative Message System, the bulletin is being sent to you in 3 separate PDF files. Attached below is the 3rd file. For the 1st file see DCS1135 and for the 2nd file see DCS1136.

**Mailing Information**

Customer letter mailing will begin on March 1, 2004 for 1998-1999 model year vehicles.

**GM Vehicle Inquiry System (GMVIS)**

GMVIS information will be available on February 24, 2004.

**Service Information System (SI)**

Bulletin 04002 is scheduled to be available in SI on March 5, 2004.

**Campaign Initiation Detail Report (CIDR)**

The CIDR will be available in DealerWorld February 23, 2004.

Due to part availability, this recall is being conducted in 3 phases. Phase 1 will consist of 1998 and 1999 model year vehicles; phase 2 will consist of 2000 model year vehicles; and phase 3 will consist of 2001 model year vehicles. When sufficient parts are available to notify owners of 2000 and 2001 model year vehicles, you will be notified and will receive a new Initiation report.

**END OF MESSAGE**

**GM SERVICE AND PARTS OPERATIONS**

## (PART 3 OF 3)

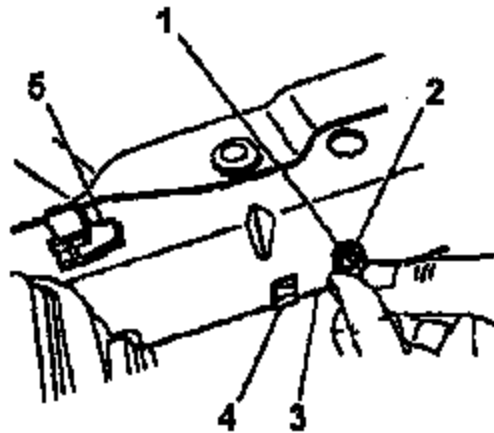
**1998-2001 J car - Cavalier/Sumfire with 2.2L Engine (VIN Code 4)**

1423721

1. Slide the J-nut (1), included in the harness kit, on the bottom edge of the upper radiator support (3) so that it is located just to the right of the existing clip (4). If there is no clip, use the prop rod holding clip (5) as a reference for determining the correct location for the J-nut.
2. With the J-nut in position, use a pencil to mark the location (2) for a 6.35 mm (1/4 in) hole to be drilled.

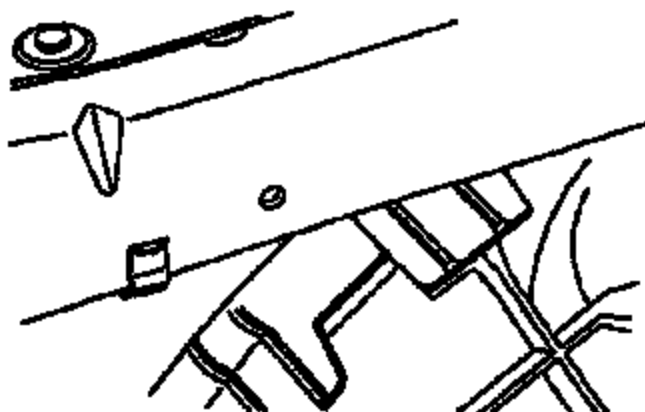

868849

3. Remove the J-nut, and using a 6.35 mm (1/4 in) drill bit, drill a hole in the radiator support at the location marked (2) in the previous step. The above illustration shows the radiator support after the hole has been drilled.
4. Touch up the drilled hole as necessary using an appropriate anti-corrosion material.
5. On the HARNESS KIT, strip the insulation back about 6.35 mm (1/4 in) on the purple wire. The purple wire is the only wire on the harness kit that does not have a terminal on it.
6. Using an appropriate crimping tool, install one end of the butt connector, included in the harness kit, on the purple wire.
7. Slide the J-nut on the bottom edge of the radiator support and over the drilled hole.

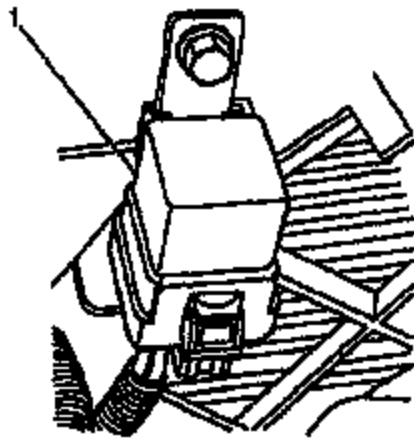

898854

- Using the 10 mm hex head bolt provided in the harness kit, attach the relay (1) to the radiator support using the previously drilled hole and J-nut. **Tighten**

Tighten the bolt to 10 N-m (89 lb in).

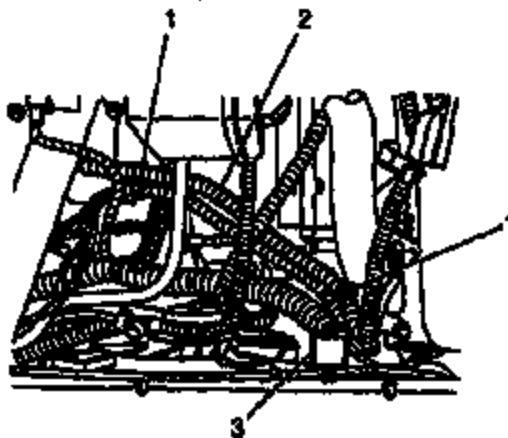

866432

### Important

The push-in barbed feature on the plastic harness clips are NOT used when attaching the wiring harnesses together in the next step.

- Route and attach the service relay harness (3) to the vehicle wiring harness (2) using the two plastic clips (1) already attached to the relay harness.
- Remove the nut from the "B" terminal of the starter and disconnect all wires and the positive battery cable from the terminal.

11. Visually inspect the condition of the "S" terminal stud and nut on the starter solenoid.
  - o If the nut and/or stud appear to be in good condition with little or no sign of corrosion, proceed to Step 19 and remove the nut. Do NOT perform Steps 12-18 if the stud and nut are in good condition.
  - o If the nut and/or stud appear to be corroded to the point where the stud may break off if removal of the nut is attempted, proceed to Step 12 of this procedure. Steps 12-14 will require the use of one ADDITIONAL butt connector, P/N 12089191. Obtain the additional butt connector before proceeding.
12. Using wire cutters, cut the purple wire off the "S" terminal of the starter solenoid, leaving approximately 50 mm (2 in) of wire on the terminal.
13. Strip the insulation back about 6.35 mm (1/4 in) on the short purple wire that remained on the starter solenoid.
14. Using an appropriate crimping tool, install one end of the butt connector, P/N 12089191, on the short purple wire.
15. Using wire cutters, cut the small ring terminal off the end of the red wire on the service harness kit.
16. Strip the insulation back about 6.35 mm (1/4 in) on the red wire.
17. Using the appropriate crimping tool, install the red wire in the other end of the butt connector that is on the starter solenoid short purple wire.
18. Using an appropriate tool, heat shrink the yellow tubing on the butt connector to shrink it into position to seal the connection.

#### **Important**

If you have just completed Steps 12-18, proceed to Step 21. Do not perform Steps 20-21. If you did NOT perform Steps 12-18, proceed to Step 19.

19. Remove the nut from the starter solenoid "S" terminal and remove all the wires from the terminal.
20. Cut the ring terminal from the vehicle wiring harness purple wire, which was removed from the "S" terminal.
21. Strip the insulation back about 6.35 mm (1/4 in) on the purple wires of the vehicle wiring harness and the service harness kit.
22. Using an appropriate crimping tool, install the other end of the butt connector, which is already installed on the harness kit, on the purple wire on the vehicle's wiring harness. Crimp the wires together firmly.
23. Using an appropriate tool, heat shrink the yellow tubing on the butt connector to shrink it into position to seal the connection.

#### **Important**

If you performed Steps 12-18 earlier, proceed to the next IMPORTANT statement prior to Step 26. Do not perform Steps 24-25. If you did NOT perform Steps 12-18 earlier, proceed to Step 24.

24. Thoroughly clean the interface surfaces of the "S" terminal. Ensure the "S" terminal is snug to the starter solenoid cap.
25. Install the small ring terminal on the red wire of the service harness kit on the "S" terminal. Reinstall the nut. **Tighten**

Tighten the nut to 2.5 N-m (22 lb in).

**Important**

In the next step, make sure the battery cable is the last cable positioned on the starter solenoid "B" terminal so that the nut is tightened against the battery cable.

26. Thoroughly clean the interface surfaces of the "B" terminal on the starter solenoid.
27. Clean the fusible link terminal on the vehicle wiring harness and install it on the starter solenoid "B" terminal.
28. Install the large ring terminal on the harness kit on the starter solenoid "B" terminal.
29. Clean and install the positive battery cable on the starter solenoid "B" terminal. Install the nut. **Tighten**

Tighten the nut to 11 N·m (97 lb in).

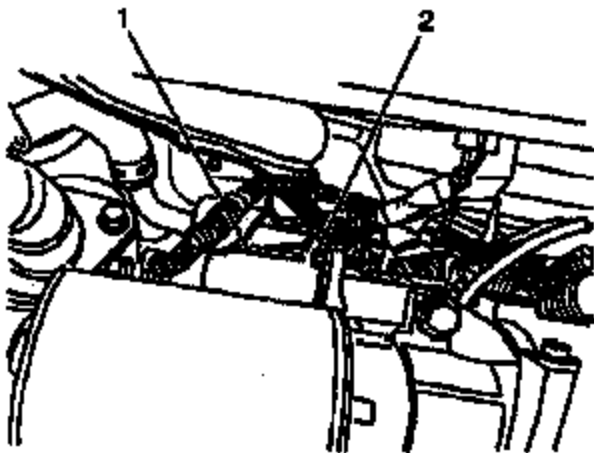

560605

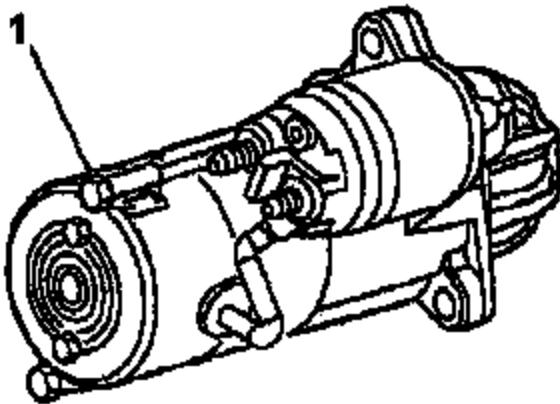

1429077

30. On 1998 models, remove one of the bolts (2) that attach the starter solenoid to the starter motor. On 1999-2001 models, remove one of the long bolts (1) that hold the starter motor end cap to the housing.



31. On 1998 models, install the ground ring terminal (black wire) on the harness kit on the bolt and reinstall the bolt in the starter solenoid. On 1999-2001 models, install the ground ring terminal (black wire) on the long bolt and reinstall the bolt in the starter. **Tighten**

Tighten the starter solenoid bolt or long starter motor bolt to 9 N·m (80 lb in).

32. Reinstall the negative battery cable to the battery. **Tighten**

Tighten the bolt to 16 N·m (12 lb ft).

#### **Important**

Do not use a remote starter device in the next step. The vehicle ignition switch must be used to start the vehicle (turn ignition switch to crank position) to verify that the ignition switch is in good working condition.

33. Using the ignition key, start the engine and allow it to run approximately 5 seconds. After 5 seconds, turn the engine off for approximately 5 seconds. Repeat this 6 times.
- o If the starter cranks the engine 6 times in a row, no further action is required
  - o If the starter will NOT crank the engine, skip to **Procedure A** for **J Car Cavalier/Sunfire**.

#### **1998-2001 J car - Cavalier/Sunfire - PROCEDURE A (all engines)**

1. Remove the small cover from the left side end of the Instrument Panel (I/P) and remove the AIR BAG fuse from the fuse panel.
2. Remove the 7 mm hex head screws that attach the left side insulator panel below the I/P and reposition the panel.
3. Remove the Connector Position Assurance (CPA) from the yellow SIR connector(s) that are clipped to the metal I/P brace near the bottom of the steering column.
4. Disconnect the yellow connectors.
5. If equipped, remove the tilt column lever.
6. Remove the three screws attaching the lower steering column cover and remove the cover.
7. Remove the upper steering column cover.

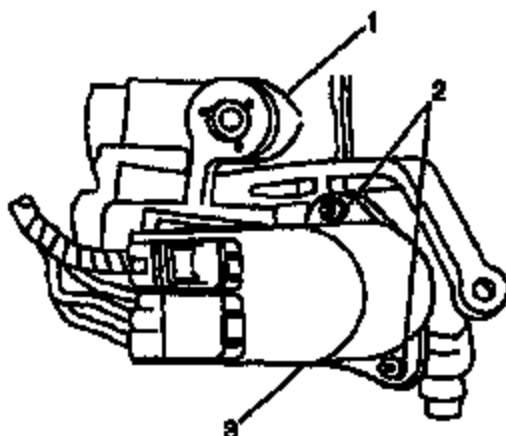

8. Remove the two TORX® head screws (2) that attach the ignition switch (3) to the column (1).
9. Remove the ignition switch from the column and disconnect the electrical connectors from the switch. Discard the switch.
10. Connect the electrical connectors to the new ignition switch.

#### Notice

The ignition switch mounting screws are self-tapping. To prevent stripping the screws when attaching the ignition switch, the following procedure should be used:

- o Place the screw into position and with slight pressure, rotate the screw in a counter-clockwise (loosening) direction.
- o When the original thread is located, the screw will drop slightly; reverse direction and tighten the screw.

11. Position the new ignition switch to the column and install the two attaching TORX® head screws. **Tighten**

Tighten the screws to 4 N·m (35 lb in).

12. Install the upper steering column cover.
13. Install the lower steering column cover and attaching screws. **Tighten**

Tighten the screws to 4 N·m (35 lb in).

14. If equipped, install a new tilt lever.
15. Connect the two yellow SIR connectors at the base of the steering column.
16. Install the CPA in each connector and clip the connector(s) to the I/P brace.
17. If equipped, position the left side insulator panel to the bottom of the I/P and install the attaching screws. **Tighten**

Tighten the screws to 2 N·m (18 lb in).

18. Install the AIR BAG fuse and install the fuse panel cover.
19. Turn the ignition switch to the ON position and verify that the AIR BAG indicator light flashes seven times and goes out.

#### CUSTOMER REIMBURSEMENT For U.S.

All customer requests for reimbursement for previous repairs for the recall condition will be handled by the Customer Assistance Center, not by dealers.

A General Motors Product Recall Customer Reimbursement Procedure Form is included with the customer letter.

**IMPORTANT:** Refer to the GM Service Policies and Procedures Manual, section 6.1.12, for specific procedures regarding customer reimbursement and the form.

**CUSTOMER REIMBURSEMENT** For Canada

Customer requests for reimbursement of previously paid repairs for ignition switch replacement and related wiring repairs due to the condition addressed in this bulletin are to be submitted by June 30, 2005.

All reasonable customer paid receipts should be considered for reimbursement. The amount to be reimbursed will be limited to the amount the repair would have cost if completed by an authorized General Motors dealer.

When a customer requests reimbursement, they must provide the following:

- Proof of ownership at time of repair.
- Original paid receipt confirming the amount of repair expense(s) that were not reimbursed, a description of the repair, and the person or entity performing the repair.

Claims for customer reimbursement on previously paid repairs are to be submitted as required by WINS.

**IMPORTANT:** Refer to the GM Service Policies and Procedures Manual, section 1.6.2, for specific procedures regarding customer reimbursement verification.

**CLAIM INFORMATION**

Submit a Product Recall Claim with the information indicated below:

REPAIR PERFORMED	PART COUNT	PART NO.	PARTS ALLOW	CC-FC	LABOR OP	LABOR HOURS	NET ITEM
Install Engine Wiring Harness Ext. Kit 1998 J Car		--	**	MA-96	V1111		***
• 2.2L	1					0.6*	
• 2.4L	2					0.9*	
1998-2001 J Car							
• 2.2L	1					0.6*	
• 2.4L	2					0.7*	
1998 N Car							
• 3.1L	1					0.5*	
• 2.4L	2					0.8*	
Add: Replace Ignition Switch & Strg Column Tilt Lever	2	--	**				N/A
• J Car						0.3	
• N Car						0.5	
Add: Install Butt Connector on Solenoid "S" Terminal as Req'd.	0	--	**			0.2	N/A
Customer Reimbursement (Canadian Dealers ONLY)	N/A	N/A	N/A	MA-96	V1112	0.2	****

\* For Program Administrative Allowance, add 0.1 hours to the "Labor Hours".

\*\* The "Parts Allowance" should be the sum total of the current GMSPO Dealer net price plus applicable Mark-Up or Landed Cost Mark-Up (for IPC) for the parts needed to complete the repair.

\*\*\* The amount identified in the "Net Item" column should represent the sum total of the current GMSPO Dealer net price plus applicable Mark-Up or Landed Cost Mark-Up (for IPC) for the motor oil and filter needed to perform the required repairs.

\*\*\*\* The amount identified in the "Net Item" column should represent the actual dollar amount reimbursed to the customer.

Refer to the General Motors WINS Claims Processing Manual for details on Product Recall Claim Submission.

**CUSTOMER NOTIFICATION – For US and CANADA**

General Motors will notify customers of this recall on their vehicle (see copy of customer letter included with this bulletin).

**CUSTOMER NOTIFICATION – For IPC**

Letters will be sent to known owners of record located within areas covered by the US National Traffic and Motor Vehicle Safety Act. For owners outside these areas, dealers should notify customers using the attached sample letter.

**DEALER RECALL RESPONSIBILITY – For US and IPC (US States, Territories, and Possessions)**

The US National Traffic and Motor Vehicle Safety Act provides that each vehicle that is subject to a recall of this type must be adequately repaired within a reasonable time after the customer has tendered it for repair. A failure to repair within sixty days after tender of a vehicle is prima facie evidence of failure to repair within a reasonable time. If the condition is not adequately repaired within a reasonable time, the customer may be entitled to an identical or reasonably equivalent vehicle at no charge or to a refund of the purchase price less a reasonable allowance for depreciation. To avoid having to provide these burdensome remedies, every effort must be made to promptly schedule an appointment with each customer and to repair their vehicle as soon as possible. In the recall notification letters, customers are told how to contact the US National Highway Traffic Safety Administration if the recall is not completed within a reasonable time.

**DEALER RECALL RESPONSIBILITY - ALL**

All unsold new vehicles in dealers' possession and subject to this recall must be held and inspected/repaired per the service procedure of this recall bulletin before customers take possession of these vehicles.

Dealers are to service all vehicles subject to this recall at no charge to customers, regardless of mileage, age of vehicle, or ownership, from this time forward.

Customers who have recently purchased vehicles sold from your vehicle inventory, and for which there is no customer information indicated on the dealer listing, are to be contacted by the dealer. Arrangements are to be made to make the required correction according to the instructions contained in this bulletin. A copy of the customer letter is provided in this bulletin for your use in contacting customers. Recall follow-up cards should not be used for this purpose, since the customer may not as yet have received the notification letter.

In summary, whenever a vehicle subject to this recall enters your vehicle inventory, or is in your dealership for service in the future, you must take the steps necessary to be sure the recall correction has been made before selling or releasing the vehicle.

GM bulletins are intended for use by professional technicians, NOT a "do-it-yourselfer". They are written to inform them of conditions that may occur on some vehicles, or to provide information that could assist in the proper service of a vehicle. Properly trained technicians have the tools, equipment, safety instructions, and know-how to do a job properly and safely. If a condition is described, DO NOT assume that the bulletin applies to your vehicle, or that your vehicle will have that condition. See your dealer/retailer for information on whether your vehicle may benefit from the information.



**We Support  
Voluntary  
Technician  
Certification**

March 2004

Dear General Motors Customer:

This notice is sent to you in accordance with the requirements of the National Traffic and Motor Vehicle Safety Act. Federal regulation requires that any vehicle lessor receiving this recall notice must forward a copy of this notice to the lessee within ten days.

General Motors has decided that a defect, which relates to motor vehicle safety, exists in certain 1998 through 2001 model year Chevrolet Cavalier and Pontiac Sunfire vehicles, and 1998 model year Buick Skylark, Oldsmobile Achieva, and Pontiac Grand Am vehicles. If the engine fails to start and the driver holds the key in the "start" position for an extended period, high current flows through the ignition switch, and sometimes produces enough heat to melt internal switch parts. If the switch is damaged, a fire could occur in the steering column, even with the engine off and the key removed. The fire could spread to the interior of the car, which could injure occupants of the car or cause damage to adjoining structures.

The purpose of this letter is to explain this product safety recall, what GM is doing to correct it, and what you can do immediately to reduce the potential for a fire and its consequences. Customers who have experienced this problem usually report that they recently had problems starting their cars. While most of the fires occurred within minutes of an unsuccessful attempt to start the car, others occurred after the car had been unattended for a longer time. If you are experiencing problems starting your car, have it repaired promptly and do not leave the car in a building.

Please know that we understand the concern this may cause and the need to correct it as quickly as we can. Until we are able to install a relay kit in your car that will prevent high current from flowing through the ignition switch, there are two very important precautions you can take to reduce the potential for a fire:

- Do not hold the key in the "start" position if the starter does not immediately begin cranking the engine. A low battery charge and other starting system problems can create a situation where the driver turns the key to the "start" position and nothing happens other than a clicking sound. If that happens, turn the key back to "off" immediately. Holding the key in "start" longer will not help to start the car, but can cause damage to the ignition switch that can eventually lead to a fire.
- If you encounter difficulty starting your car, have it repaired promptly to minimize the potential for damage to the ignition switch. The ignition switch in your vehicle may become damaged and the damage could lead to a fire if you:

(1) have a failing battery and do not replace it promptly and

- (2) experience "click" with no start three or more times and
- (3) jump-start the car three or more times

**What GM Is Doing:** Your GM dealer will (1) install a relay kit that will prevent high current from flowing through the ignition switch and (2) check that your car will start with a properly charged battery and, if necessary, replace the ignition switch. These services will be performed for you at no charge. Battery replacement and other normal maintenance, however, are not covered by this recall.

**Contacting Your Dealer:** To limit any possible inconvenience, we recommend that you contact your GM dealer as soon as possible to schedule an appointment for this repair. By scheduling an appointment, your dealer can ensure that the necessary parts will be available on your schedule appointment date. Should your dealer be unable to schedule a service date within a reasonable time, you should contact the appropriate Customer Assistance Center at the listed number below:

Division	Number	Text Telephones (TTY)
Buick	1-866-608-8080	1-800-832-8425
Chevrolet	1-800-630-2438	1-800-833-2438
Pontiac	1-800-620-7668	1-800-833-7668
Oldsmobile	1-800-630-6537	1-800-833-6537
Puerto Rico – English	1-800-496-9992	
Puerto Rico – Español	1-800-496-9993	
Virgin Islands	1-800-496-9994	

If, after contacting the appropriate Customer Assistance Center, you are still not satisfied that we have done our best to remedy this condition without charge and within a reasonable time, you may wish to write the Administrator, National Highway Traffic Safety Administration, 400 Seventh Street, SW, Washington, DC 20590 or call 1-888-327-4236.

**How Long Will The Repair Take?** This service correction will take approximately 1 to 1-1/2 hours. However, due to service scheduling requirements, your dealer may need your vehicle for a longer period of time.

**Customer Reimbursement:** The enclosed form explains what reimbursement is available and how to request reimbursement if you have paid for repairs for the recall condition.

**Customer Reply Card:** The attached customer reply card identifies your vehicle. Presentation of this card to your dealer will assist in making the necessary correction in the shortest possible time. If you no longer own this vehicle, please let us know by completing the attached and mailing it in the postage paid envelope.

**Recall Information Online:** More information about this recall (including answers to frequently asked questions) is available online at the Owner Center at My GMLink. This free online service offers vehicle and ownership-related

information and tools tailored to your specific vehicle. To join, visit [www.mygmllink.com](http://www.mygmllink.com) and enter your car's Vehicle Identification Number (VIN), shown on the attached card, to get the most personalized information for your vehicle.

We are sorry to cause you this inconvenience; however, we have taken this action in the interest of your safety and continued satisfaction with our products.

General Motors Corporation

Enclosure