



04F-093

MITSUBISHI FUSO

TRUCK OF AMERICA, Inc.

2015 Center Square Road

Logan Twp., NJ 08085

(856) 467-4500

(856) 467-4695 Fax

August 31, 2004

Jonathan D. White, Chief, Defects and Recall Information Analysis Division
Office of Defects Investigation, Safety Assurance
U.S. Department of Transportation
National Highway Traffic Safety Administration, Room 5219
400 Seventh Street, S.W.
Washington, DC 20590

**Subject: Mitsubishi Fuso Truck & Bus Corporation Foreign Recall Advanced Information
(Substantially Similar Vehicle)**

Dear Mr. White:

On August 30, 2004, Mitsubishi Fuso Truck and Bus Corporation (MFTBC), Japan advised Mitsubishi Fuso Truck of America, Inc. (MFTA) that MFTBC has decided to conduct a safety recall campaign in a foreign country involving vehicles that are substantially similar to vehicles offered for sale in the United States. Please see the details of the foreign recall below:

1. Manufacturer's Name

Mitsubishi Fuso Truck & Bus Corporation (MFTBC), Japan

2. Identification of Vehicles/Production Period

- FK603, FK612, FK615, FK616, FK617, FK618, FK619, FK622, FK627, FK628, FK629, FK662, FK666, FK667, FK668, FK672, FK678, FL618, FL628, FL638, FL639, FM612, FM616, FM618, FM619, FM622, FM628, FM629, FM652, FM656, FM658, FN612, FN622
- Production Period: June 29, 1992 to September 29, 1998
- Model Years: In the Japan domestic medium-duty truck market, vehicles are not identified by model year. The trucks are identified by production date and chassis number only. The chassis number includes the engine serial number, the vehicle model code, and the production date. The trucks are not identified by Vehicle Identification Number (VIN), as they are in the U.S.

3. Number of Vehicles Involved

102,404 units (Japan: 91,622; Export: 10,782)

Export Vehicle Details:

AUSTRALIA	1687	ERITREA	3	MYAMAR	8	ST. LUCIA	2
BAHRAIN	10	ETHIOPIA	2	MYANMAR	4	SUDAN	1
BANGLADESH	5	FIJI	4	NEPAL	1	SYRIA	16
BARBADOS	56	GHANA	45	NEW GUINEA	2	TAIWAN	1379
BENIN	6	HONG KONG	525	NEW ZEALAND	390	TANZANIA	67
BERMUDA	6	INDONESIA	1	NICARAGUA	6	THAILAND	99
BRUNEI	135	JAMAICA	3	NIGER	1	TONGA	1
BURKINA FASO	2	KENYA	127	NORTH KOREA	5	TRINIDAD & TOBAGO	93
CAMBODIA	4	KUWAIT	26	OMAN	130	U.A.E.	95
CAPE VERDE	10	LAOS	2	PAKISTAN	36	U.S.A.(MFTA)	2621
CHINA	16	MADAGASCAR	1	PERU	10	UGANDA	37
COMMONWEALTH OF DOMINICA	1	MALAWI	9	PHILIPPINE	1	VANUATU	4
COTE D'IVOIRE	29	MALAYSIA	109	QATAR	31	VENEZUELA	618
CUBA	15	MAURITIUS	65	RWANDA	1	VIETNAM	14
DOMINICAN REP.	35	MMC OTHERS	6	SAUDI ARABIA	313	W.AFRICA OTHERS	6
ECUADOR	29	MONGOLIA	2	SINGAPORE	753	YEMEN	6
EGYPT	18	MOROCCO	896	SOLOMON ISLANDS	1	ZAMBIA	16
EQUADOR	2	MOZAMBIQUE	13	SRILANKA	84	ZIMBABWE	25

4. Defect Description

On affected vehicles, the clearance between the cab main hook and the surrounding components may be insufficient. Repeated normal cab tilting operation could cause the cab tilt system components to become damaged in the area of the cab main hook. If damage occurs, the cab main hook could latch improperly, and in the worst case, the cab could tilt forward during normal vehicle operation.

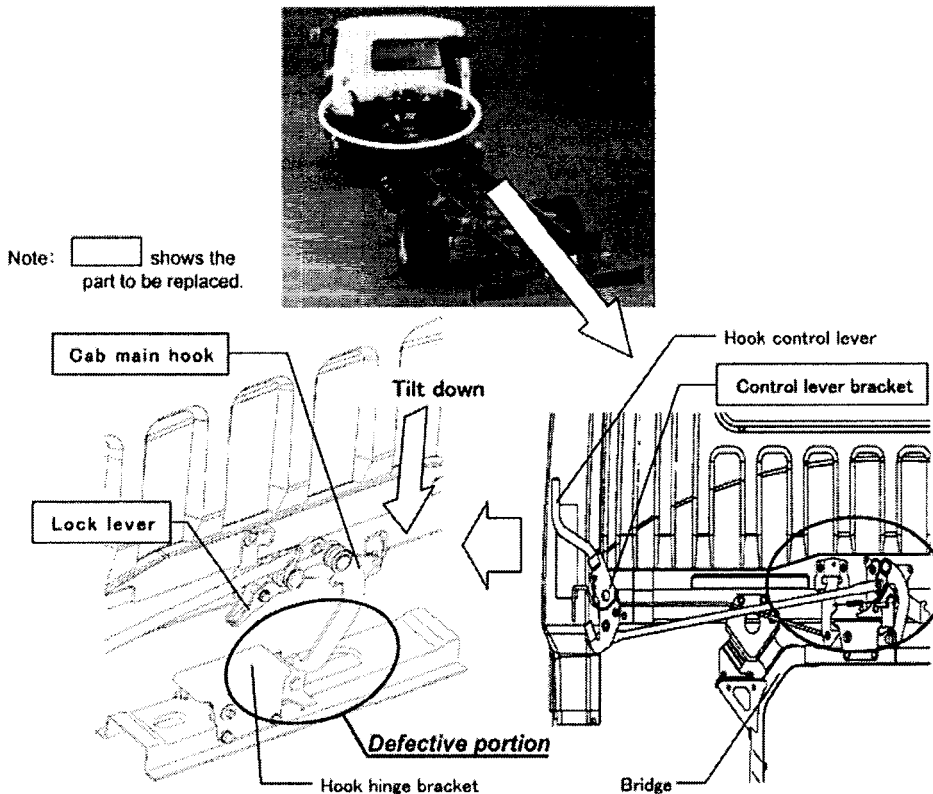

5. Foreign countries where safety recall will be launched:
Japan, and all other countries listed in the table above
6. Safety Recall or other Safety Campaign:
Safety Recall
7. Recall determination, government or manufacturer:
Manufacturer
8. Remedy
Replace the cab hook, lock lever and control lever bracket with modified components.
9. Date Campaign will start:
Notification to MLIT: September 1, 2004
Notification to vehicle owners: September 2, 2004
10. Substantially Similar Vehicles:
Truck models offered for sale in the U.S. by MFTA that are substantially similar to trucks involved in this campaign are the 1996-2004 FK617, 1996-2004 FM617 and 1996-2004 FM657. **Please Note: The same cab tilting system is used on MFTBC trucks manufactured in Japan and offered for sale by MFTA in the USA. MFTBC will notify MFTA of the details of a recall campaign for vehicles in the U.S. market shortly.**

If you have any questions or concerns, please do not hesitate to contact me at the number listed below.

Sincerely,



William P. Mohr
Director, Service Operations
Mitsubishi Fuso Truck of America, Inc.
Phone: (856) 467-3917 Fax: (856) 467-4665

c: K. Idota (MFTBC)
T. Kawai (MFTBC)
H. Imamura (MFTA)