

TOYOTA CUSTOMER SERVICES

Volume: XI
Number: TC04-022
Date: 12/06/2004
 Action
 Retain
 Information

INTEROFFICE MEMORANDUM

TO: ALL REGION/PRIVATE DISTRIBUTOR GENERAL MANAGERS/
VICE PRESIDENTS

FROM: DAVE ZELLERS, 
VICE PRESIDENT, PRODUCT QUALITY & SERVICE SUPPORT

SUBJECT: SPECIAL SERVICE CAMPAIGN (SSC) – 40M
(2004 THROUGH EARLY 2005 MODEL YEAR TOYOTA CAMRY RIGHT FRONT
POWER SEAT, SEAT BELT BUCKLE STATUS SWITCH REPLACEMENT)

Toyota will initiate a voluntary Special Service Campaign (SSC) to replace the right front seat belt buckle status switch on certain 2004 through early 2005 Model Year (MY) Toyota Camry vehicles equipped with a right front power seat.

The National Highway Traffic Safety Administration (NHTSA) recently conducted a front passenger seat airbag suppression test on a Toyota Camry vehicle. The NHTSA discovered that, when installing certain rear-facing infant child seat bases onto the front passenger seat, it was possible to unseat a component called the buckle status switch (switch) from the seat belt buckle. If the switch becomes unseated, the front passenger occupant classification system may mistake the rear-facing child restraint for an unbelted adult occupant, and may not suppress the deployment of the front passenger airbag.

Please note that Toyota recommend that a rear-facing child restraint is ***never*** installed in the front passenger seat, even if the passenger "Airbag OFF" lamp is illuminated. ***The safest place for children is in the rear seat.***

The following vital information is provided to inform you and your staff of the campaign notification schedule and your degree of involvement.

1. **Dealer Letter Mailing Date**

The attached Dealer Letter will be mailed to all Toyota dealers in mid-December, 2004.

2. **Owner Notification Mailing Date**

The owner notification will commence in late December, 2004. We have attached a copy of the owner notification letter for your reference.

If a dealer is contacted by an owner of an involved vehicle, who has not yet received a notification, please instruct them to verify eligibility through Dealer Daily or TIS. Dealers should perform repairs as outlined in the attached Technical Instructions.

3. **Number of Vehicles Involved**

Nationally, there are approximately 68,000 Model Year 2004 and early 2005 Camry vehicles involved in this campaign.

4. Region/District Summary Reports

We have enclosed the following SSC 40M Summary Reports in the Region/Private Distributor (PD) Service Manager/Customer Service Operations Manager/Director of Service package:

- Region/PD Summary Report that provides an overview of the entire Region/PD for this campaign.
- District Summary Report that indicates the number of involved vehicles per dealership in each district for this campaign.

5. Vehicles in Dealer Stock

As required by Federal Regulation, dealers are not to deliver any vehicle acquired in their inventory, which is involved in a Special Service Campaign, until the necessary repairs have been performed.

6. Parts Ordering

The necessary parts can be ordered through the dealer's facing PDC. Please refer to the table below and the Technical Instructions for part number information.

TMC Production (VIN begins with JT)

Part No.	Parts Name	Q'ty/ Vehicle
73121-33010	Seat Belt Buckle Status Switch	1

TMMK Production (VIN begins with 4T)

Part No.	Parts Name	Q'ty/ Vehicle
73121-33020	Seat Belt Buckle Status Switch	1

To prevent parts shortages and excess parts stock at dealerships, the "Suggested Initial Parts Order Quantity" has been provided in each Dealer Inventory List (sent to each dealer's Service and Parts Managers) as a guide. This will assure an adequate and balanced parts inventory for this SSC. The Region/District Summary Reports include a summary of the "Suggested Initial Parts Order Quantity" recommended to each dealer.

7. Reimbursement Procedures

Please refer to the Reimbursement Procedures found in the attached Dealer Letter.

Please review this entire Special Service Campaign package with the appropriate associates so that they may provide the necessary support to your dealers and maximize our combined customer satisfaction efforts. Thank you for your cooperation.

TOYOTA MOTOR SALES, U.S.A, INC.
Enclosures



Toyota Motor Sales, U.S.A., Inc.
19001 South Western Avenue
P.O. Box 2991
Torrance, CA 90509-2991

TO: ALL TOYOTA DEALER PRINCIPALS,
SERVICE MANAGERS, PARTS MANAGERS

SUBJECT: SPECIAL SERVICE CAMPAIGN (SSC) – 40M
(2004 THROUGH EARLY 2005 MODEL YEAR TOYOTA CAMRY RIGHT FRONT
POWER SEAT, SEAT BELT BUCKLE STATUS SWITCH REPLACEMENT)

Toyota will initiate a voluntary Special Service Campaign (SSC) to replace the right front seat belt buckle status switch on certain 2004 through early 2005 Model Year (MY) Toyota Camry vehicles equipped with a right front power seat.

The National Highway Traffic Safety Administration (NHTSA) recently conducted a front passenger seat airbag suppression test on a Toyota Camry vehicle. The NHTSA discovered that, when installing certain rear-facing infant child seat bases onto the front passenger seat, it was possible to unseat a component called the buckle status switch (switch) from the seat belt buckle. If the switch becomes unseated, the front passenger occupant classification system may mistake the rear-facing child restraint for an unbelted adult occupant, and may not suppress the deployment of the front passenger airbag.

Please note that Toyota recommend that a rear-facing child restraint is *never* installed in the front passenger seat, even if the passenger "Airbag OFF" lamp is illuminated. ***The safest place for children is in the rear seat.***

The following vital information is provided to inform you and your staff of the campaign notification schedule and your degree of involvement.

1. **Owner Notification Letter Mailing Date**

The owner notification will commence in late December, 2004.

If you are contacted by an owner of an involved vehicle, who has not yet received a notification, please verify eligibility by confirming through Dealer Daily or TIS prior to performing repairs. Dealers should perform repairs as outlined in the attached Technical Instructions.

2. **Dealer/Owner Lists**

Dealer/Owner Lists for this campaign have been distributed to each dealership's Service and Parts Managers. These lists are based on selling dealership. Dealerships which did not sell an affected vehicle, or do not have affected vehicles in stock, will receive a report indicating so.

3. **Vehicles in Dealer Stock**

As required by Federal Regulation, dealers are not to deliver any vehicle acquired in their inventory, which is involved in a Special Service Campaign, until the necessary repairs have been performed.

4. Identification of Involved Vehicles

Nationally, there are approximately 68,000 Model Year 2004 and early 2005 Camry vehicles equipped with a **Right Front Power Seat** involved in this campaign.

Model	Year	VIN Range	
		VDS	Ranges
TMC Production Camry	2004	BE30K	0244954 - 0301974
		BE32K	0245057 - 0300761
		BF30K	0151821 - 0158353
		BF32K	0151989 - 0158338
	2005	BE30K	0302052 - 0313153
		BE32K	0302096 - 0310833
		BF30K	0158373 - 0159271
		BF32K	0158361 - 0159261

Model	Year	VIN Range	
		VDS	Ranges
TMMK Production Camry	2004	BE30K	U208121 - U381315 U788219 - U940882
		BE32K	U259104 - U381272 U726931 - U940891
		BF30K	U062091 - U082147 U567259 - U590020
		BF32K	U051662 - U082152 U567095 - U590025
	2005	BE30K	U378869 - U408186 U912362 - U969400
		BE32K	U380259 - U408240 U886640 - U969271
		BF30K	U081966 - U088640 U581825 - U594662
		BF32K	U081835 - U088621 U582489 - U594664

NOTE: Not all vehicles in the VIN ranges are involved in this SSC. Always consult Dealer Daily or TIS to confirm VIN eligibility and to assure the SSC is applicable. This will verify the vehicle is involved and has not already been completed by another dealer or prior to dealer delivery. TMS warranty will not reimburse dealers for repairs conducted on vehicles that are not affected.

5. Repair Procedures

Refer to the attached Technical Instructions.

6. Parts Ordering

The necessary parts can be ordered through the dealer's facing PDC. Please refer to the table below and the Technical Instructions for part number information.

TMC Production (VIN begins with JT)

Part No.	Parts Name	Q'ty/ Vehicle
73121-33010	Seat Belt Buckle Status Switch	1

TMMK Production (VIN begins with 4T)

Part No.	Parts Name	Q'ty/ Vehicle
73121-33020	Seat Belt Buckle Status Switch	1

To prevent parts shortages and excess parts stock at dealerships, the "Suggested Initial Parts Order Quantity" has been provided in each Dealer Inventory List (sent to each dealer's Service and Parts Managers) as a guide. This will assure an adequate and balanced parts inventory for this SSC. The Region/District Summary Reports include a summary of the "Suggested Initial Parts Order Quantity" recommended to each dealer.

A UIO by state matrix is listed below to inform dealers of the number of vehicles in their area.

STATE	UIO	STATE	UIO	STATE	UIO	STATE	UIO	STATE	UIO
AK	29	GA	1,531	ME	239	NJ	2,786	SD	104
AL	877	IA	595	MI	1,089	NM	298	TN	1,255
AR	415	ID	184	MN	1,124	NV	571	TX	3,405
AZ	1,407	IL	3,571	MO	1,128	NY	3,956	UT	376
CA	9,242	IN	1,041	MS	392	OH	2,544	VA	2,772
CO	671	KS	527	MT	106	OK	485	VT	87
CT	1,000	KY	943	NC	2,016	OR	833	WA	1,750
DC	133	LA	880	ND	113	PA	2,937	WI	1,091
DE	292	MA	2,287	NE	357	RI	337	WV	329
FL	5,508	MD	2,681	NH	456	SC	844	WY	63

7. Reimbursement Procedures

Submit Special Service Campaign claims following the procedures described in the Toyota Warranty Policy and Procedures Manual.

The operation code to be used for this Special Service Campaign is:

SSC #	Op. Code	Description	Flat Rate Hour
40M	4630L1	Replace Right Front Seat Belt Buckle Status Switch	0.7 hr/vehicle

NOTE: The above flat rate time includes 0.1 hours of administrative cost per unit for the dealership.

Please review this entire package with your Service and Parts staff to familiarize them with the proper step-by-step procedures required to implement this Special Service Campaign.

Thank you for your cooperation.

TOYOTA MOTOR SALES, U.S.A., INC.

**2004 to early 2005 Model Year Camry
Special Service Campaign 40M –Right Front Power Seat, Seat Belt Buckle Status Switch**

Dear Toyota Owner:

Thank you very much for your patronage of Toyota. We are dedicated to providing vehicles of outstanding quality and value. As part of our continuing efforts to provide superior customer satisfaction, Toyota is announcing a Special Service Campaign Program on 2004 to early 2005 model year Camry vehicles equipped with a right front power seat.

What is the condition?

The National Highway Traffic Safety Administration (NHTSA) recently conducted a front passenger seat airbag suppression test on a Toyota Camry vehicle. NHTSA discovered that, when installing certain rear-facing infant child seat bases onto the front passenger seat, it was possible to unseat a component called the buckle status switch (switch) from the seat belt buckle. If the switch becomes unseated, the front passenger occupant classification system may mistake the rear-facing child restraint for an unbelted adult occupant, and may not suppress the deployment of the front passenger airbag.

If this condition were to occur when using a rear-facing child restraint in the front passenger seat, you would be alerted by both the flashing red seat belt warning lamp, and the yellow passenger "Airbag ON" lamp on the vehicle dashboard. In this condition, do not operate the vehicle with a rear-facing child restraint installed in the front passenger seat. In the event of a crash, the force of the rapid inflation of the front passenger airbag can cause death or serious injury to the child if the rear-facing child restraint system is installed on the front passenger seat.

Please note that Toyota recommends that you *never* install a rear-facing child restraint in the front passenger seat, even if the passenger "Airbag OFF" lamp is illuminated. ***The safest place for children is in the rear seat.*** Please refer to your Owners Manual for additional details.

What will Toyota do?

Any Toyota dealer will replace the front passenger seat inner seat belt buckle status switch with an upgraded one at **NO COST** to you.

This offer is only available from your local Toyota dealer.

What should you do?

Contact any Toyota dealer and make an appointment to replace the buckle status switch with an upgraded one as soon as possible.

The actual repair will take approximately one hour. However, depending upon the dealer's work schedule, it may be necessary to make your vehicle available for a longer period of time.

Please present this notice to the dealer at the time of your service appointment.

If you no longer own the vehicle, please indicate so on the enclosed postage-paid form, providing us with the name and address of the new owner.

What if you have any other questions?

Your local Toyota dealer will be more than happy to answer any of your questions and set up an appointment to perform the installation. If you require further assistance, you may contact the Toyota Customer Experience Center at 1-888-270-9371 Monday through Friday, 5:00 am to 9:30 pm, Saturday and Sunday 7:00 am through 3:00 pm Pacific Standard Time.

We have sent this notice in the interest of your continued satisfaction with our products, and we sincerely regret any inconvenience this condition may have caused you.

Sincerely,

TOYOTA MOTOR SALES, U.S.A., INC.



**Special Service Campaign (SSC) Q&A
2004 to early 2005 Model Year Toyota Camry
Right Front Power Seat, Seat Belt Buckle Status Switch**

Q1: What is the condition?

A1: The National Highway Traffic Safety Administration (NHTSA) recently conducted a front passenger seat airbag suppression test on a Toyota Camry vehicle. NHTSA discovered that, when installing certain rear-facing infant child seat bases onto the front passenger seat, it was possible to unseat a component called the buckle status switch (switch) from the seat belt buckle. If the switch becomes unseated, the front passenger occupant classification system may mistake the rear-facing child restraint for an unbelted adult occupant, and may not suppress the deployment of the front passenger airbag.

If this condition were to occur when using a rear-facing child restraint in the front passenger seat, you would be alerted by both the flashing red seat belt warning lamp, and the yellow passenger "Airbag ON" lamp on the vehicle dashboard. In this condition, do not operate the vehicle with a rear-facing child restraint installed in the front passenger seat. In the event of a crash, the force of the rapid inflation of the front passenger airbag can cause death or serious injury to the child if the rear-facing child restraint system is installed on the front passenger seat.

Please note that Toyota recommends that you *never* install a rear-facing child restraint in the front passenger seat, even if the passenger "Airbag OFF" lamp is illuminated. **The safest place for children is in the rear seat.** Please refer to your Owner's Manual for additional details.

Q2: What is the function of the seat belt buckle status switch?

A2: The buckle status switch located on the seat belt buckle, detects whether the seat belt is fastened or unfastened.

Q3: What is the cause of this condition?

A3: If the child seat base is installed onto the front passenger seat with excessively high belt tension, the combination of the child seat base and the right front seat cushion height setting could deflect the seat belt buckle from its normal position. As a result, the status switch retaining clip could release, and the switch could disengage from the buckle.

Q4: Are there any warnings that this condition exists?

A4: Yes, if this condition were to occur the driver would be alerted by a flashing red seat belt warning light and the yellow passenger "Airbag ON" light located on the dash.

Q5: Which and how many vehicles are involved?

A5: Certain 2004 to early 2005 Model Year Camry equipped with a right front power seat and 2004 to early 2005 Model Year Lexus ES 330 vehicles are involved. There are approximately 68,000 Camry (TMC and TMMK production) and 81,000 ES 330 vehicles involved in the U.S.

Q6: What is the production period of the affected vehicles?

A6: The affected Toyota Camry vehicles were produced:
TMC July, 2003 through September, 2004.
TMMK May, 2003 through September, 2004.

Q7: Are there any other Toyota or Lexus vehicles involved?

A7: Yes, this condition also affects certain 2004 to early 2005 Model Year ES 330 vehicles.

Q8: How many incidents of this condition have been reported?

A8: There have been no cases reported in for this condition in the affected vehicles.

Q9: Have there been any accidents reported?

A9: There have been no reported cases of accidents related to this condition.

Q10: What is Toyota going to do?

A10: Owners of the involved vehicles will receive a Special Service Campaign notification by first class mail beginning in late December, 2004. Toyota dealers will replace the right front seat belt buckle status switch at **NO COST** to the vehicle owners.

Q11: How long will the repair take?

A11: The repair will take approximately one hour. However, depending upon the dealer's work schedule, it may be necessary to make the vehicle available for a longer period of time.

Q12: What should an owner do if they experience the condition?

A12: Owners are requested to contact their local Toyota dealer for diagnosis and repair.

TECHNICAL INSTRUCTIONS

FOR

SPECIAL SERVICE CAMPAIGN 40M

2004 through early 2005 CAMRY
RIGHT FRONT POWER SEAT, BELT BUCKLE
STATUS SWITCH REPLACEMENT

I. OPERATION FLOW CHART

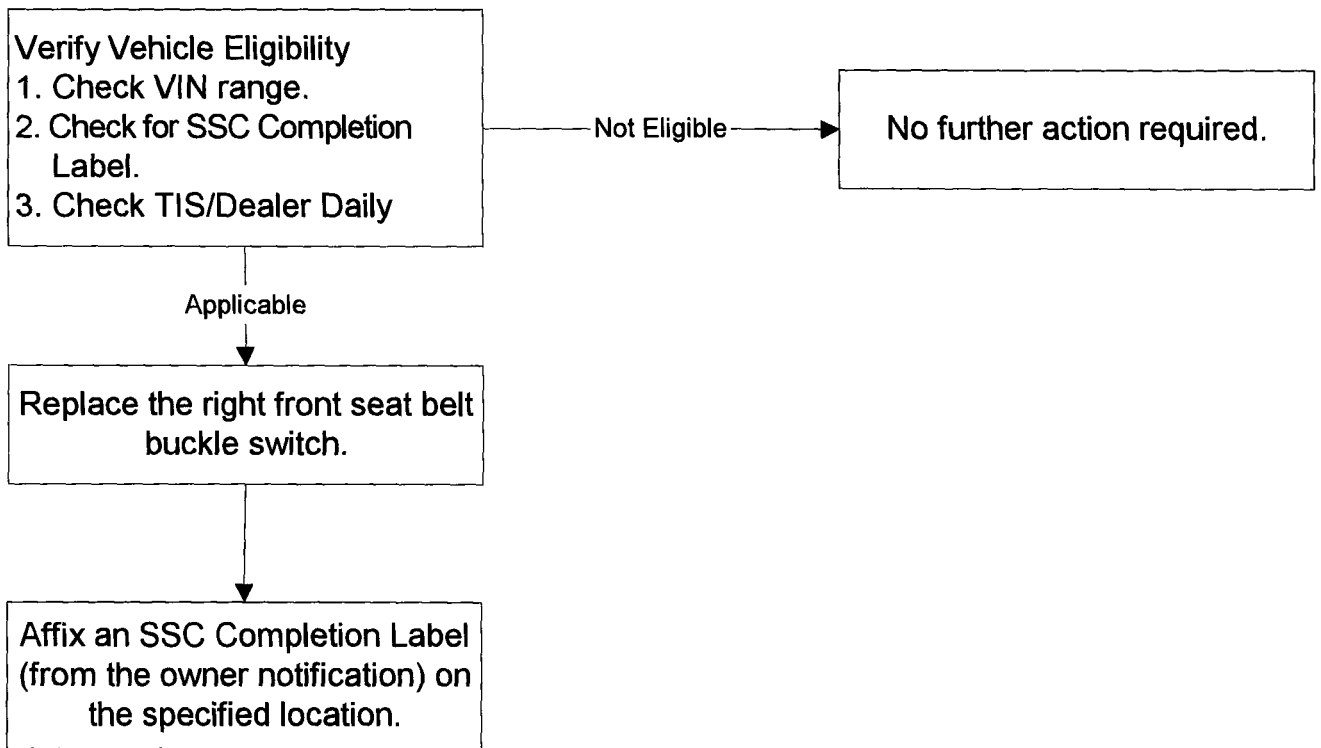

II. IDENTIFICATION OF AFFECTED VEHICLES

A. AFFECTED VIN RANGE

Model	Year	VIN Range	
		VDS	Ranges
TMC Production Camry	2004	BE30K	0244954 - 0301974
		BE32K	0245057 - 0300761
		BF30K	0151821 - 0158353
		BF32K	0151989 - 0158338
	2005	BE30K	0302052 - 0313153
		BE32K	0302096 - 0310833
		BF30K	0158373 - 0159271
		BF32K	0158361 - 0159261

Model	Year	VIN Range	
		VDS	Ranges
TMMK Production Camry	2004	BE30K	U208121 - U381315 U788219 - U940882
		BE32K	U259104 - U381272 U726931 - U940891
		BF30K	U062091 - U082147 U567259 - U590020
		BF32K	U051662 - U082152 U567095 - U590025
	2005	BE30K	U378869 - U408186 U912362 - U969400
		BE32K	U380259 - U408240 U886640 - U969271
		BF30K	U081966 - U088640 U581825 - U594662
		BF32K	U081835 - U088621 U582489 - U594664

NOTE: Not all vehicles in the VIN range are affected by this SSC. Always consult Dealer Daily or TIS to confirm VIN eligibility and to assure the SSC is applicable. This will verify the vehicle is involved and has not already been completed by another dealer. TMS warranty will not reimburse dealers for repairs conducted on vehicles that are not affected.

III. PREPARATION

A. PARTS

TMC Production

Part No.	Parts Name	Q'ty/ Vehicle
73121-33010	Seat Belt Buckle Status Switch	1

TMMK Production

Part No.	Parts Name	Q'ty/ Vehicle
73121-33020	Seat Belt Buckle Status Switch	1

B. TOOLS

- Standard hand tools
- Torque wrench
- Toyota scantool

C. COMPONENTS

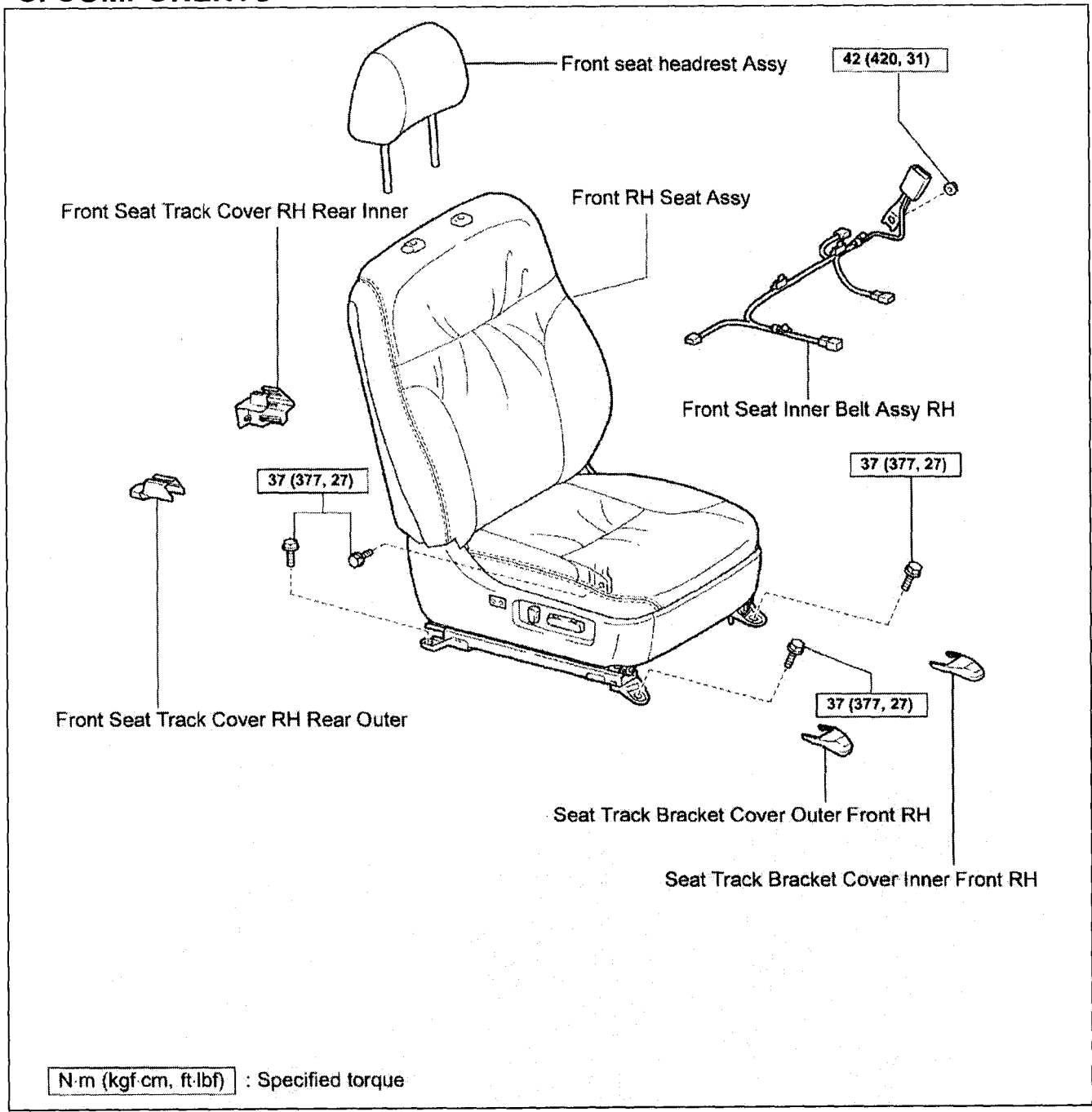

IV. WORK PROCEDURE

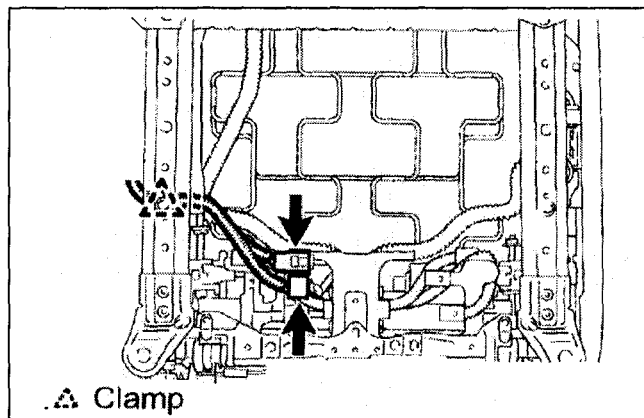
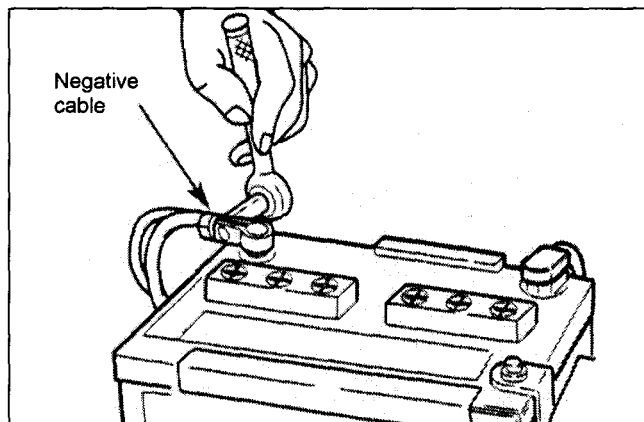
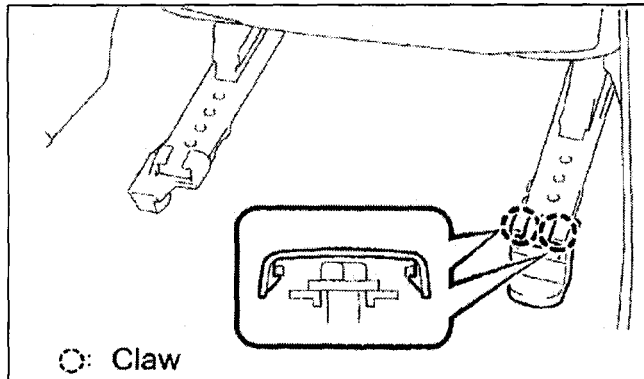
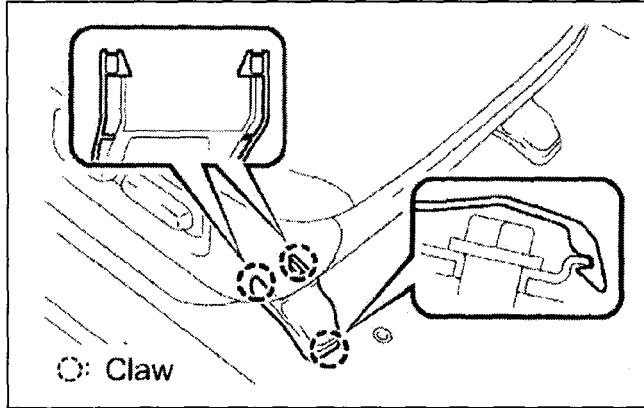

1. REMOVE THE RIGHT FRONT SEAT

- (a) Remove the headrest.
- (b) Place the backrest in the upright position.
- (c) Move the seat fully to the rear.
- (d) Disengage the 3 claws for the front outer seat track cover.
- (e) Remove the seat track cover.
- (f) Remove the front inner seat track cover.
- (g) Remove the 2 front seat bolts.

- (h) Move the seat fully forward.
- (i) Disengage the 2 claws for the outer seat track cover.
- (j) Remove the seat track cover.
- (k) Remove the rear inner seat track cover.
- (l) Remove the 2 rear seat bolts.

- (m) Record audio station presets.
- (n) Disconnect the negative battery cable.

NOTE:

Wait a minimum of two minutes before working on any part of SRS system. This allows the SRS reserve system to power down.

- (m) Disconnect the clamp and the connector located under the seat.
- (n) Disconnect the clamp and connectors for the power seat motors, and SRS system.

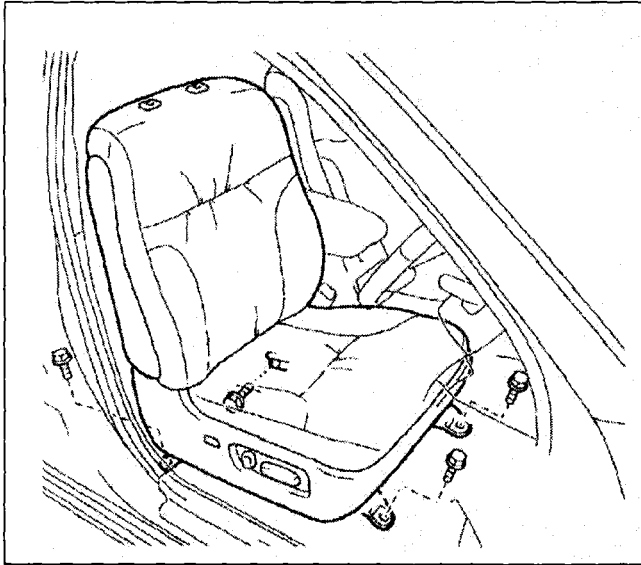

(o) Remove the seat.

NOTE:

The yaw sensor is mounted to the floor under the right front seat and could be damaged during seat removal and installation.

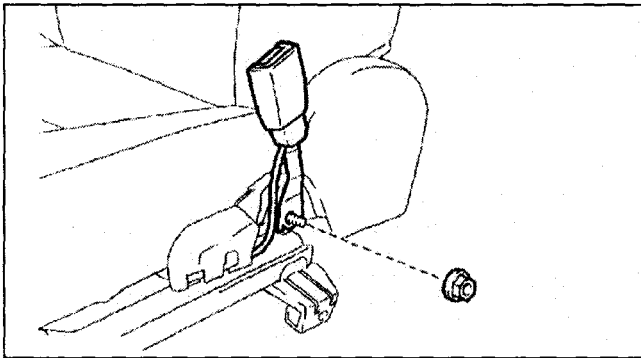

2. REPLACE THE SEAT BELT BUCKLE SWITCH

- (a) Remove the seat belt buckle nut.
- (b) Remove the seat belt buckle.

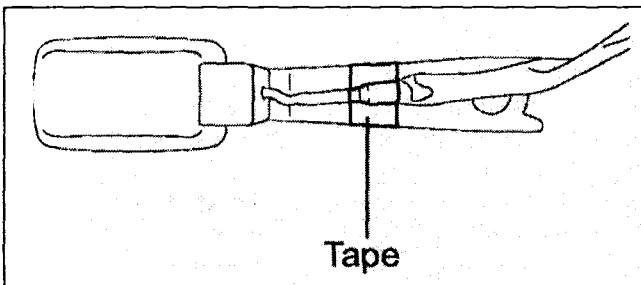

- (c) Remove the tape holding the wire harness to the buckle.

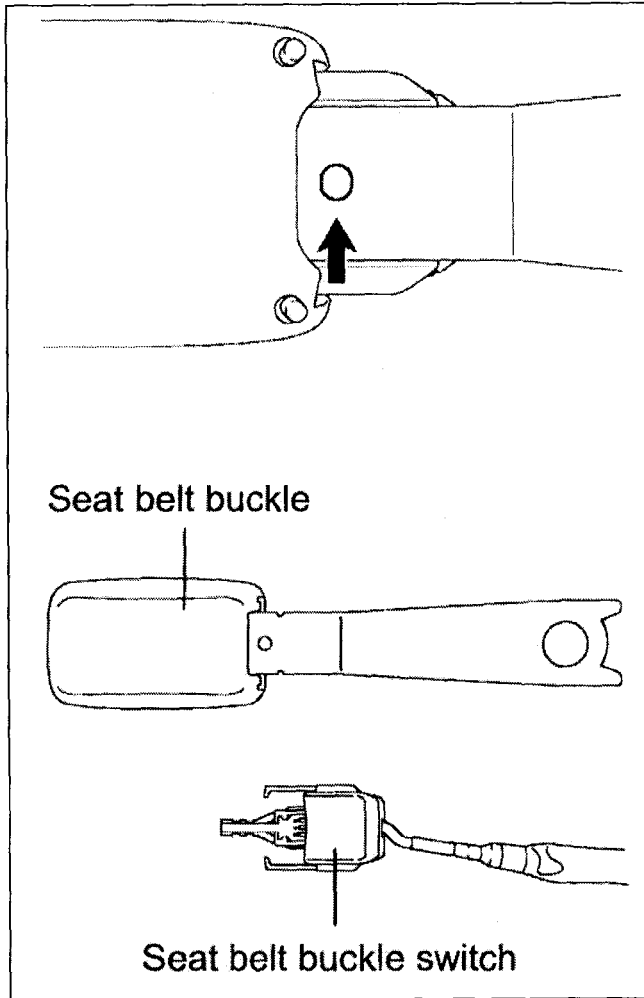

- (d) Using a small pin punch, release the clip holding the switch assembly to the buckle.
- (e) Remove the switch assembly from the buckle.

NOTE:
Pull the switch straight back from the buckle.

Claw Inserting Positions:

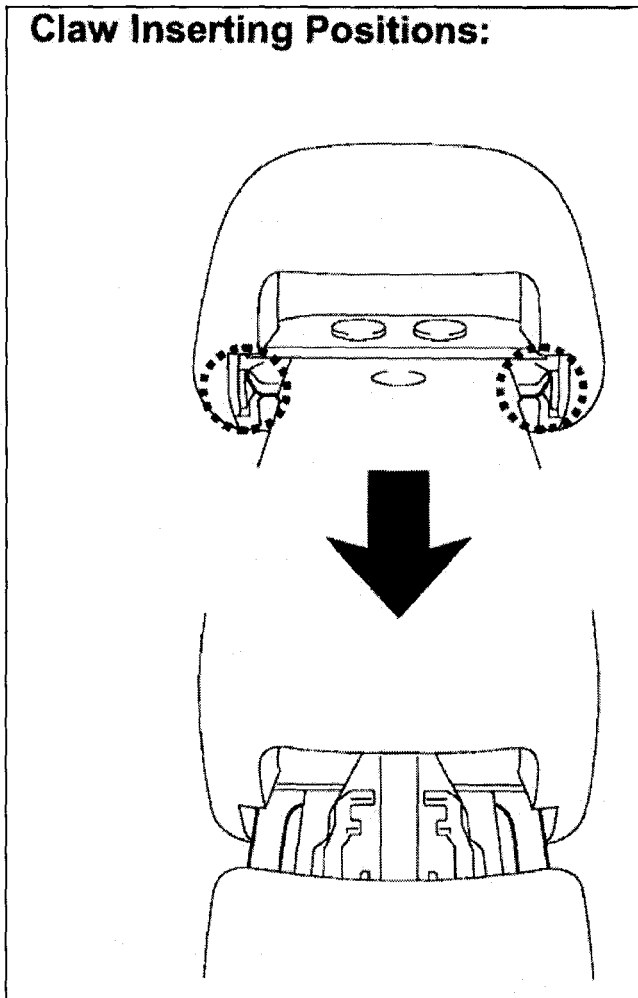

- (f) Install the new switch assembly into the buckle.

NOTE:

Ensure that the new switch assembly engages into the buckle. There will be an audible click when the switch is correctly engaged into the buckle.

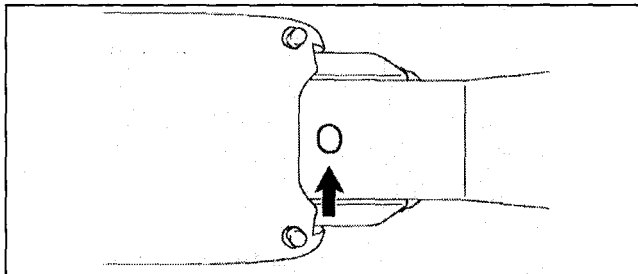

- (g) Ensure that the tab is securely inserted into the hole in the seat belt buckle.

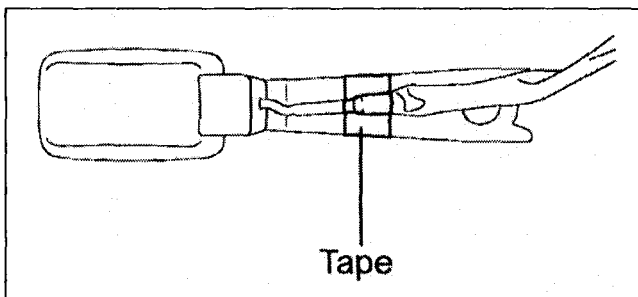

- (h) Retape the harness to the buckle as shown.

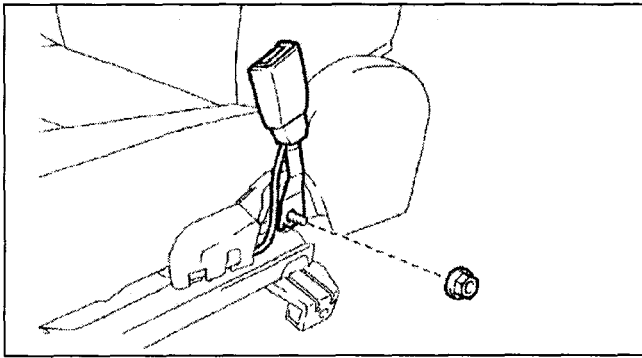

- (i) Reinstall the seal belt buckle.
- (j) Reinstall the nut.

Torque:
42N·m (420 kgf·cm, 31 ft·lb)

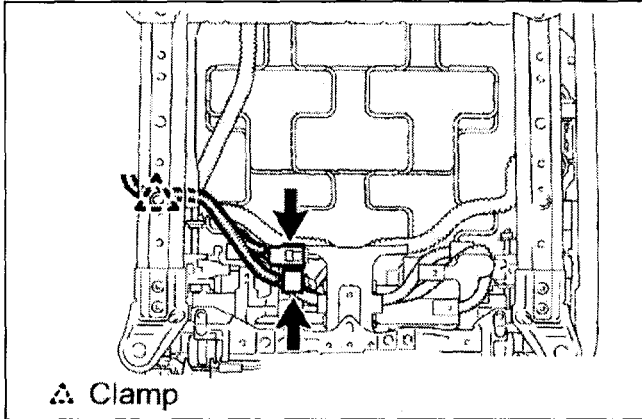

3. REINSTALL THE RIGHT FRONT SEAT

- (a) Reinstall seat into the vehicle.
- (b) Reconnect the connector and the clamp.
- (c) Reconnect the clamp and connectors for the power seat motors, and SRS system.

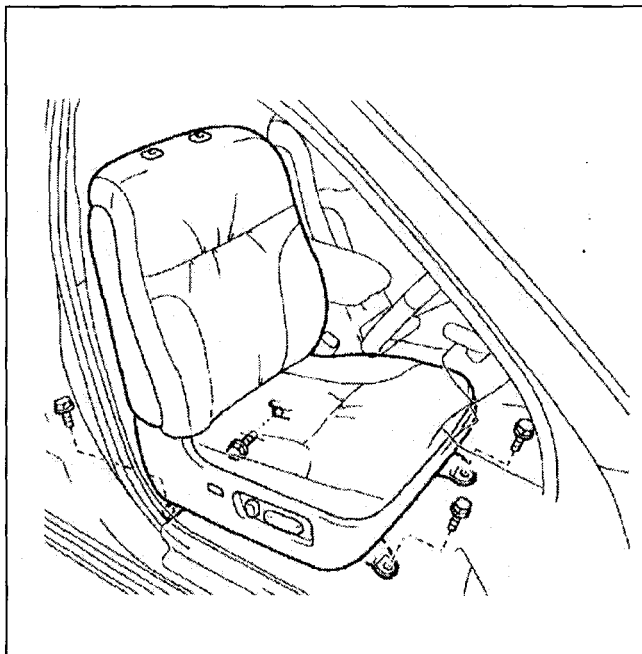

- (d) Reconnect the negative battery terminal.
- (e) Move the seat fully to the rear.
- (f) Reinstall the 2 front seat bolts.

Torque:
37N·m (377 kgf·cm, 27 ft·lb)

- (f) Reinstall the 2 front seat track covers.
- (g) Move the seat fully forward.
- (h) Reinstall the 2 rear seat bolts.

Torque:
37N·m (377 kgf·cm, 27 ft·lb)

- (i) Reinstall the 2 rear seat track covers.
- (j) Reinstall the headrest.

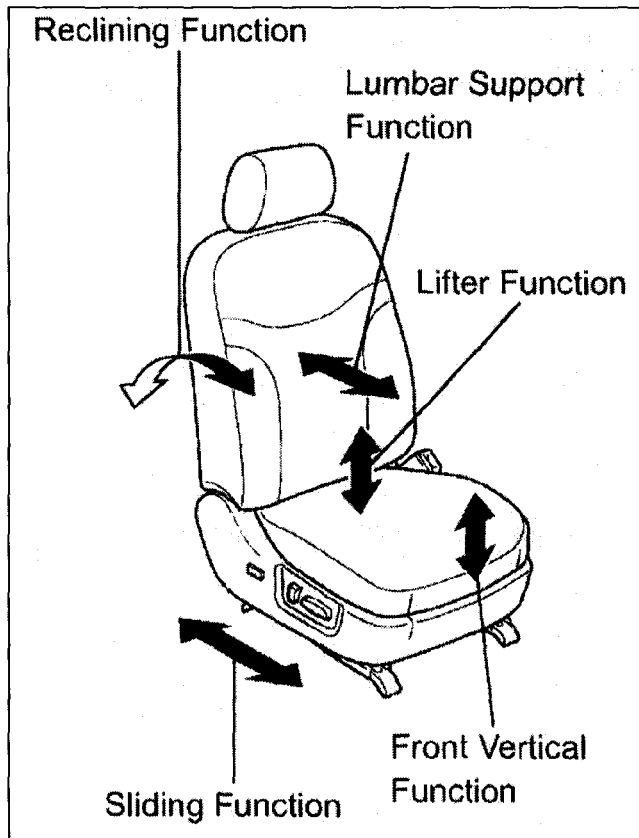

4. INSPECT POWER SEAT OPERATION

- (a) Using the power seat controls, check that the following seat functions operate properly:
- Fore and aft movement
 - Front vertical
 - Lifter
 - Backrest recline
 - Lumbar support (if equipped)
 - Seat heater (if equipped)

5. INITIALIZE THE FRONT RIGHT FRONT SEAT OCCUPANT CLASSIFICATION SYSTEM

NOTE:

The zero point calibration and sensitivity check must be preformed after this repair has been completed. Refer to the appropriate repair manual for the passenger seat initialization.

V. SSC COMPLETION LABEL INSTALLATION

After completing the repair and before returning the vehicle to the owner, an SSC completion label, which is enclosed in the owner's notification, must be affixed to the left front door hinge post, near the check strap.

(a) The label is to be filled out as follows:

- Write in SSC 40M
- Write in date of repair.
- Write in your dealer code.

SSC	Date
DEALER CODE NO.	
00410-01917	

(b) Additional SSC completion labels, in sheets of 50 (P/N 00410-01917), may be ordered through the non-parts system on a 1450 order form or through the TDN system.



Via Overnight Mail
December 8, 2004

To: Area General Manager
Jerry
From: Jerry Marcotti – Service and Parts Operations Manager
Subject: Special Service Campaign (SSC) 4LI
2004 – Early 2005 ES 330 Right Front Seat Belt Buckle Status Switch

Lexus has initiated a Special Service Campaign (SSC) on certain 2004 to early 2005 model year ES 330 vehicles. Campaign details and the degree of your area's involvement are summarized in this communication.

Condition

The National Highway Traffic Safety Administration (NHTSA) recently conducted a front passenger seat airbag suppression test on a Lexus ES 330 platform vehicle. NHTSA discovered that, when installing certain rear-facing infant child seat bases onto the front passenger seat, it was possible to unseat a component called the buckle status switch (switch) from the seat belt buckle. If the switch becomes unseated, the front passenger occupant classification system may mistake the rear-facing child restraint for an unbelted adult occupant, and may not suppress the deployment of the front passenger air bag.

If this condition were to occur when using a rear-facing child restraint in the front passenger seat, you would be alerted by both the flashing red seat belt warning lamp, and the yellow passenger "Airbag ON" lamp on the vehicle dashboard. In this condition, do not operate the vehicle with a rear-facing child restraint installed in the front passenger seat. In the event of a crash, the force of the rapid inflation of the front passenger airbag can cause death or serious injury to the child if the rear-facing child restraint system is installed on the front passenger seat.

Please note that Lexus recommends that customers ***never*** install a rear-facing child restraint in the front passenger seat, even if the passenger "Airbag OFF" lamp is illuminated. ***The safest place for children is in the rear seat.*** Please refer customers to their Owner's Manual for additional details.

SSC 4LI Repair

SSC 4LI involves replacing the right front seat belt buckle status switch.

For further information refer to the attached Lexus Q&A and customer notification letter.

Dealer and Owner Notification Date

Dealer notification packages with the dealer letter and handbook will be sent via Next Day UPS delivery to the attention of the service manager on Friday, December 10, 2004.

Owner notification letters will be mailed in phases to the owners of affected vehicles starting in late December 2004.

Identification of Involved Vehicles

Special Service Campaign 4LI only applies to specific 2004 to early 2005 model year ES 330 vehicles within VIN ranges listed below.

Year	Model	VIN	
		VDS	Range
2004	ES 330	BA30G	0001015 - 0023605 5000006 - 5055753
2005	ES 330	BA30G	0023185 - 0024154 5045822 - 5067460

Note: Not all vehicles in the VIN range are affected by this SSC. You should always consult Dealer Daily or TIS to confirm VIN eligibility and to assure the SSC is applicable. This will verify that the vehicle is involved and has not already been completed by another dealer. TMS Warranty will not reimburse dealers for repairs conducted on vehicles that are not affected.

Implementation at Dealerships

The SSC dealer package contains the SSC 4LI dealer handbook explaining warranty claim procedures, parts information, and technical instructions. Please make sure that Service Department staff (especially Service Managers, Service Consultants, Warranty Administrators, Technicians, and Diagnostic Specialists) review the SSC 4LI handbook and understand their role in this campaign.

Tools and Equipment

Dealers will need standard hand tools, a torque wrench, and a Lexus scan tool to perform this repair.

Parts

Part Number	Part Description	Qty.
73121-33030	Seat Belt Buckle Status Switch	1

This part has not been put on the Dealer Stocking Guide (D.S.G.). Please encourage your dealers to order only those parts needed to repair vehicles with service appointments. Individual dealer tracking will be done and irregularities in quantity ordering will be passed on to Lexus Area Offices for follow-up and correction. There will be sufficient inventory to accommodate this SSC.

Customer Care

- Customer lists are **not** being sent to you or your dealers due to various privacy regulations in effect throughout the nation. However, dealers have the ability through their DMS systems to query their database and create their own customer lists for use in contacting customers in regard to this Special Service Campaign.
- Lexus Touch Amenities - The usual customer care amenities (car wash, fuel fill-up and loaner vehicles) apply to this SSC.

Reimbursement Procedures

Dealers are required to submit SSC claims following the procedures described in the SSC 4LI handbook.

Repair	Claim Type	Model	Opcode	Labor Hours*	Sublet
Replace right front seat belt buckle status switch	SC	ES 330	4630L1	0.7	GA (fuel), TW (tow), RT (loaner vehicle), DE (pick-up and delivery or remote repair), or CW (car wash) as required and substantiated by invoices

* Includes 0.1 labor hours for administrative time.

Note: Lexus warranty will only accept one claim per vehicle under the terms of the SSC. Please ensure your dealership checks the National Service History File or TIS to see if the vehicle has been repaired under this SSC prior to servicing the vehicle.

Dealer System Communications

- The VIN number information download will be performed over the weekend of December 11 and 12, 2004.

- The operation code will be downloaded and available for your dealership to use over the weekend of December 11 and 12, 2004. DMS dealer files are automatically updated and no further action should be required.

Dealer Support Materials

Additional quantities of the SSC handbook (m/n 00241-10006-4LI) are available at no cost to order from the Materials Distribution Center (MDC).

Thank you for your understanding. Your attention to your dealers during this campaign protects our mutual customers and their image of Lexus.

Attachments

**Cc: Area Customer Satisfaction Manager
Area Operations Manager
Area Pre-Owned Manager
Area Technical Manager
Assistant General Manager
District Service and Parts Manager
District Technical Manager
Field Technical Specialist
Product Field Engineer**



Special Service Campaign (SSC) Q&A

2004 to early 2005 Model Year Lexus ES 330 Right Front Seat Belt Buckle Status Switch

Q1: What is the condition?

A1: The National Highway Traffic Safety Administration (NHTSA) recently conducted a front passenger seat airbag suppression test on a Lexus ES 330 platform vehicle. NHTSA discovered that, when installing certain rear-facing infant child seat bases onto the front passenger seat, it was possible to unseat a component called the buckle status switch (switch) from the seat belt buckle. If the switch becomes unseated, the front passenger occupant classification system may mistake the rear-facing child restraint for an unbelted adult occupant, and may not suppress the deployment of the front passenger airbag.

If this condition were to occur when using a rear-facing child restraint in the front passenger seat, you would be alerted by both the flashing red seat belt warning lamp, and the yellow passenger "Airbag ON" lamp on the vehicle dashboard. In this condition, do not operate the vehicle with a rear-facing child restraint installed in the front passenger seat. In the event of a crash, the force of the rapid inflation of the front passenger airbag can cause death or serious injury to the child if the rear-facing child restraint system is installed on the front passenger seat.

Please note that Lexus recommends that you **never** install a rear-facing child restraint in the front passenger seat, even if the passenger "Airbag OFF" lamp is illuminated. ***The safest place for children is in the rear seat.*** Please refer to your Owner's Manual for additional details.

Q2: What is the function of the seat belt buckle status switch?

A2: The buckle status switch located on the seat belt buckle, detects whether the seat belt is fastened or unfastened.

Q3: What is the cause of this condition?

A3: If the child seat base is installed onto the front passenger seat with excessively high belt tension, the combination of the child seat base and the right front seat cushion height setting could deflect the seat belt buckle from its normal position. As a result, the status switch retaining clip could release, and the switch could disengage from the buckle.

Q4: Are there any warnings that this condition exists?

A4: Yes, if this condition were to occur the driver would be alerted by a flashing red seat belt warning light and the yellow passenger "Airbag On" light located on the dash.

Q5: Which and how many vehicles are involved?

A5: Certain 2004 to early 2005 Model Year ES 330 vehicles. Also certain 2004 to early 2005 Model Year Toyota Camry vehicles equipped with a right front power seat are involved. There are approximately 81,000 ES 330 vehicles and 68,000 Camry (TMC and TMMK production) involved in the U.S.

Q6: What is the production period of the affected vehicles?

A6: The affected Lexus ES 330 vehicles were produced from July, 2003 through September, 2004.

Q7: Are there any other Toyota or Lexus vehicles involved?

A7: Yes, this condition also affects certain 2004 to early 2005 Model Year Camry vehicles.

Q8: How many incidents of this condition have been reported?

A8: There have been no cases reported in for this condition in the affected vehicles.

Q9: Have there been any accidents reported?

A9: There have been no reported cases of accidents related to this condition.

Q10: What is Lexus going to do?

A10: Owners of the involved vehicles will receive a Special Service Campaign notification by first class mail beginning in late December, 2004. Lexus dealers will replace the right front seat belt buckle status switch at **NO COST** to the vehicle owners.

Q11: How long will the repair take?

A11: The repair will take approximately one hour. However, depending upon the dealer's work schedule, it may be necessary to make the vehicle available for a longer period of time.

Q12: What should an owner do if they experience the condition?

A12: Owners are requested to contact their local Lexus dealer for diagnosis and repair.

**2004 to early 2005 Model Year ES 330
Special Service Campaign 4LI –Right Front Seat Belt Buckle Status Switch**

Dear Lexus Owner:

Thank you very much for your patronage of Lexus. We are dedicated to providing vehicles of outstanding quality and value. As part of our continuing efforts to provide superior customer satisfaction, Lexus is announcing a Special Service Campaign Program on 2004 to early 2005 model year ES 330 vehicles.

What is the condition?

The National Highway Traffic Safety Administration (NHTSA) recently conducted a front passenger seat airbag suppression test on a Lexus ES 330 platform vehicle. NHTSA discovered that, when installing certain rear-facing infant child seat bases onto the front passenger seat, it was possible to unseat a component called the buckle status switch (switch) from the seat belt buckle. If the switch becomes unseated, the front passenger occupant classification system may mistake the rear-facing child restraint for an unbelted adult occupant, and may not suppress the deployment of the front passenger airbag.

If this condition were to occur when using a rear-facing child restraint in the front passenger seat, you would be alerted by both the flashing red seat belt warning lamp, and the yellow passenger "Airbag ON" lamp on the vehicle dashboard. In this condition, do not operate the vehicle with a rear-facing child restraint installed in the front passenger seat. In the event of a crash, the force of the rapid inflation of the front passenger airbag can cause death or serious injury to the child if the rear-facing child restraint system is installed on the front passenger seat.

Please note that Lexus recommends that you *never* install a rear-facing child restraint in the front passenger seat, even if the passenger "Airbag OFF" lamp is illuminated. ***The safest place for children is in the rear seat.*** Please refer to your Owner's Manual for additional details.

What will Lexus do?

Any Lexus dealer will replace the front passenger seat inner seat belt buckle status switch with an upgraded one at **NO COST** to you.

This offer is only available from your local Lexus dealer.

What should you do?

Contact any Lexus dealer and make an appointment to replace the buckle status switch with an upgraded one as soon as possible.

The actual repair will take approximately one hour. However, depending upon the dealer's work schedule, it may be necessary to make your vehicle available for a longer period of time.

Please present this notice to the dealer at the time of your service appointment.

If you no longer own the vehicle, please indicate so on the enclosed postage-paid form, providing us with the name and address of the new owner.

What if you have any other questions?

Please contact any Lexus dealer or call the Lexus Customer Assistance Center at 1-800-255-3987.

We have sent this notice in the interest of your continued satisfaction with our products, and we sincerely regret any inconvenience this condition may have caused you.

Sincerely,

LEXUS DIVISION
TOYOTA MOTOR SALES, U.S.A., INC.



Via Overnight Mail
December 10, 2004

**Subject: Special Service Campaign (SSC) 4LI
2004 – Early 2005 ES 330 Right Front Seat Belt Buckle Status Switch**

Dear Dealer Principal:

Lexus has initiated a Special Service Campaign (SSC) on certain 2004 to early 2005 model year ES 330 vehicles. Campaign details and the degree of your dealership's involvement are summarized in this communication.

Condition

The National Highway Traffic Safety Administration (NHTSA) recently conducted a front passenger seat airbag suppression test on a Lexus ES 330 platform vehicle. NHTSA discovered that, when installing certain rear-facing infant child seat bases onto the front passenger seat, it was possible to unseat a component called the buckle status switch (switch) from the seat belt buckle. If the switch becomes unseated, the front passenger occupant classification system may mistake the rear-facing child restraint for an unbelted adult occupant, and may not suppress the deployment of the front passenger air bag.

If this condition were to occur when using a rear-facing child restraint in the front passenger seat, you would be alerted by both the flashing red seat belt warning lamp, and the yellow passenger "Airbag ON" lamp on the vehicle dashboard. In this condition, do not operate the vehicle with a rear-facing child restraint installed in the front passenger seat. In the event of a crash, the force of the rapid inflation of the front passenger airbag can cause death or serious injury to the child if the rear-facing child restraint system is installed on the front passenger seat.

Please note that Lexus recommends that customers **never** install a rear-facing child restraint in the front passenger seat, even if the passenger "Airbag OFF" lamp is illuminated. **The safest place for children is in the rear seat.** Please refer customers to their Owner's Manual for additional details.

SSC 4LI Repair

SSC 4LI involves replacing the right front seat belt buckle status switch.

For further information refer to the attached Lexus Q&A and customer notification letter.

Owner Notification Date

Owner notification letters will be mailed in phases to the owners of affected vehicles starting

in late December 2004.

Identification of Involved Vehicles

Special Service Campaign 4LI only applies to specific 2004 to early 2005 model year ES 330 vehicles within VIN ranges listed below.

Year	Model	VIN	
		VDS	Range
2004	ES 330	BA30G	0001015 - 0023605 5000006 - 5055753
2005	ES 330	BA30G	0023185 - 0024154 5045822 - 5067460

Note: Not all vehicles in the VIN range are affected by this SSC. You should always consult Dealer Daily or TIS to confirm VIN eligibility and to assure the SSC is applicable. This will verify that the vehicle is involved and has not already been completed by another dealer. TMS Warranty will not reimburse dealers for repairs conducted on vehicles that are not affected.

Implementation at Dealerships

The SSC dealer package contains the SSC 4LI dealer handbook explaining warranty claim procedures, parts information, and technical instructions. Please make sure that Service Department staff (especially Service Managers, Service Consultants, Warranty Administrators, Technicians, and Diagnostic Specialists) review the SSC 4LI handbook and understand their role in this campaign.

Tools and Equipment

Your dealership will need standard hand tools, a torque wrench, and a Lexus scan tool to perform this repair.

Parts

Part Number	Part Description	Qty.
73121-33030	Seat Belt Buckle Status Switch	1

This part has not been put on the Dealer Stocking Guide (D.S.G.). Please encourage your parts department to order only those parts needed to repair vehicles with service

appointments. Individual dealer tracking will be done and irregularities in quantity ordering will be passed on to Lexus Area Offices for follow-up and correction. There will be sufficient inventory to accommodate this SSC.

Customer Care

- Customer lists are **not** being sent to you due to various privacy regulations in effect throughout the nation. However, you have the ability through your DMS system to query your database and create your own customer list for use in contacting customers in regard to this Special Service Campaign.
- Lexus Touch Amenities - The usual customer care amenities (car wash, fuel fill-up and loaner vehicles) apply to this SSC.

Reimbursement Procedures

Dealers are required to submit SSC claims following the procedures described in the SSC 4LI handbook.

Repair	Claim Type	Model	Opcode	Labor Hours*	Sublet
Replace right front seat belt buckle status switch	SC	ES 330	4630L1	0.7	GA (fuel), TW (tow), RT (loaner vehicle), DE (pick-up and delivery or remote repair), or CW (car wash) as required and substantiated by invoices

* Includes 0.1 labor hours for administrative time.

Note: Lexus warranty will only accept one claim per vehicle under the terms of the SSC. Please ensure your dealership checks the National Service History File or TIS to see if the vehicle has been repaired under this SSC prior to servicing the vehicle.

Dealer System Communications

The VIN number information download has been performed. The operation code has been downloaded and is available for your dealership to use. DMS dealer files are automatically updated and no further action should be required.

Dealer Support Materials

Additional quantities of the SSC handbook (m/n 00241-10006-4LI) are available at no cost to order from the Materials Distribution Center (MDC).

Thank you for your understanding. Your attention to these owners during this campaign

protects our customers and their image of Lexus.

Sincerely,

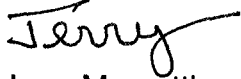
A handwritten signature in black ink that reads "Jerry". The signature is written in a cursive style with a long horizontal stroke extending to the right.

Jerry Marcotti
Service and Parts Operations Manager

Attachments

Cc: Customer Satisfaction Manager
General Manager
Parts Manager
Service Manager



Special Service Campaign (SSC) Q&A

2004 to early 2005 Model Year Lexus ES 330 Right Front Seat Belt Buckle Status Switch

Q1: What is the condition?

A1: The National Highway Traffic Safety Administration (NHTSA) recently conducted a front passenger seat airbag suppression test on a Lexus ES 330 platform vehicle. NHTSA discovered that, when installing certain rear-facing infant child seat bases onto the front passenger seat, it was possible to unseat a component called the buckle status switch (switch) from the seat belt buckle. If the switch becomes unseated, the front passenger occupant classification system may mistake the rear-facing child restraint for an unbelted adult occupant, and may not suppress the deployment of the front passenger airbag.

If this condition were to occur when using a rear-facing child restraint in the front passenger seat, you would be alerted by both the flashing red seat belt warning lamp, and the yellow passenger "Airbag ON" lamp on the vehicle dashboard. In this condition, do not operate the vehicle with a rear-facing child restraint installed in the front passenger seat. In the event of a crash, the force of the rapid inflation of the front passenger airbag can cause death or serious injury to the child if the rear-facing child restraint system is installed on the front passenger seat.

Please note that Lexus recommends that you *never* install a rear-facing child restraint in the front passenger seat, even if the passenger "Airbag OFF" lamp is illuminated. ***The safest place for children is in the rear seat.*** Please refer to your Owner's Manual for additional details.

Q2: What is the function of the seat belt buckle status switch?

A2: The buckle status switch located on the seat belt buckle, detects whether the seat belt is fastened or unfastened.

Q3: What is the cause of this condition?

A3: If the child seat base is installed onto the front passenger seat with excessively high belt tension, the combination of the child seat base and the right front seat cushion height setting could deflect the seat belt buckle from its normal position. As a result, the status switch retaining clip could release, and the switch could disengage from the buckle.

Q4: Are there any warnings that this condition exists?

A4: Yes, if this condition were to occur the driver would be alerted by a flashing red seat belt warning light and the yellow passenger "Airbag On" light located on the dash.

Q5: Which and how many vehicles are involved?

A5: Certain 2004 to early 2005 Model Year ES 330 vehicles. Also certain 2004 to early 2005 Model Year Toyota Camry vehicles equipped with a right front power seat are involved. There are approximately 81,000 ES 330 vehicles and 68,000 Camry (TMC and TMMK production) involved in the U.S.

Q6: What is the production period of the affected vehicles?

A6: The affected Lexus ES 330 vehicles were produced from July, 2003 through September, 2004.

Q7: Are there any other Toyota or Lexus vehicles involved?

A7: Yes, this condition also affects certain 2004 to early 2005 Model Year Camry vehicles.

Q8: How many incidents of this condition have been reported?

A8: There have been no cases reported in for this condition in the affected vehicles.

Q9: Have there been any accidents reported?

A9: There have been no reported cases of accidents related to this condition.

Q10: What is Lexus going to do?

A10: Owners of the involved vehicles will receive a Special Service Campaign notification by first class mail beginning in late December, 2004. Lexus dealers will replace the right front seat belt buckle status switch at **NO COST** to the vehicle owners.

Q11: How long will the repair take?

A11: The repair will take approximately one hour. However, depending upon the dealer's work schedule, it may be necessary to make the vehicle available for a longer period of time.

Q12: What should an owner do if they experience the condition?

A12: Owners are requested to contact their local Lexus dealer for diagnosis and repair.

**2004 to early 2005 Model Year ES 330
Special Service Campaign 4LI –Right Front Seat Belt Buckle Status Switch**

Dear Lexus Owner:

Thank you very much for your patronage of Lexus. We are dedicated to providing vehicles of outstanding quality and value. As part of our continuing efforts to provide superior customer satisfaction, Lexus is announcing a Special Service Campaign Program on 2004 to early 2005 model year ES 330 vehicles.

What is the condition?

The National Highway Traffic Safety Administration (NHTSA) recently conducted a front passenger seat airbag suppression test on a Lexus ES 330 platform vehicle. NHTSA discovered that, when installing certain rear-facing infant child seat bases onto the front passenger seat, it was possible to unseat a component called the buckle status switch (switch) from the seat belt buckle. If the switch becomes unseated, the front passenger occupant classification system may mistake the rear-facing child restraint for an unbelted adult occupant, and may not suppress the deployment of the front passenger airbag.

If this condition were to occur when using a rear-facing child restraint in the front passenger seat, you would be alerted by both the flashing red seat belt warning lamp, and the yellow passenger "Airbag ON" lamp on the vehicle dashboard. In this condition, do not operate the vehicle with a rear-facing child restraint installed in the front passenger seat. In the event of a crash, the force of the rapid inflation of the front passenger airbag can cause death or serious injury to the child if the rear-facing child restraint system is installed on the front passenger seat.

Please note that Lexus recommends that you *never* install a rear-facing child restraint in the front passenger seat, even if the passenger "Airbag OFF" lamp is illuminated. ***The safest place for children is in the rear seat.*** Please refer to your Owner's Manual for additional details.

What will Lexus do?

Any Lexus dealer will replace the front passenger seat inner seat belt buckle status switch with an upgraded one at **NO COST** to you.

This offer is only available from your local Lexus dealer.

What should you do?

Contact any Lexus dealer and make an appointment to replace the buckle status switch with an upgraded one as soon as possible.

The actual repair will take approximately one hour. However, depending upon the dealer's work schedule, it may be necessary to make your vehicle available for a longer period of time.

Please present this notice to the dealer at the time of your service appointment.

If you no longer own the vehicle, please indicate so on the enclosed postage-paid form, providing us with the name and address of the new owner.

What if you have any other questions?

Please contact any Lexus dealer or call the Lexus Customer Assistance Center at 1-800-255-3987.

We have sent this notice in the interest of your continued satisfaction with our products, and we sincerely regret any inconvenience this condition may have caused you.

Sincerely,

LEXUS DIVISION
TOYOTA MOTOR SALES, U.S.A., INC.



2004 – Early 2005 ES 330

Right Front Seat Belt Buckle Status Switch Replacement

Special Service Campaign 4LI

M/N 00241-10006-4LI

December 2004

PREPARING FOR THE 4LI SSC

Overview.....	3
4LI Condition	3
4LI Repair.....	4
Customer Notification	4
SSC and Customer Satisfaction	4
Identifying Affected Vehicles.....	4
Manpower and Facility Requirements	5
Tools and Equipment.....	6
Technical Training	6
Parts.....	6
DMS Systems.....	6
Planning Your Communication Strategy	6
Calls to Your Customers.....	9
Calls from Your Customers.....	9
Calls from the Media.....	9

IMPLEMENTING THE 4LI SSC

Car Rental and Service Loaners	10
Remote Area Service Plan.....	10
The Service Write-Up	11
Preparing for Delivery after SSC Completion	11
Delivery of the Vehicle after SSC Completion.....	12
Follow-Up	12
Work Order Closing/Claim Submission.....	12
Recap of Claim Submission and General Provisions of the SSC.....	13
Claiming Reimbursement for Special Services	13
Claim Preparation Instructions.....	14
Customer Letter.....	15

TECHNICAL INSTRUCTIONS

Operation Flow Chart.....	17
Identification of Affected Vehicles	17
Preparation	17
Components	18
Work Procedure.....	19
SSC Completion Label Installation.....	24

PREPARING FOR THE SSC

Overview

Lexus is initiating a Special Service Campaign (SSC). The 4LI SSC is for 2004 to early 2005 model year ES 330s. The National Highway Traffic Safety Administration (NHTSA) recently conducted a front passenger seat airbag suppression test on a Lexus ES 330 platform vehicle. NHTSA discovered that, when installing certain rear-facing infant child seat bases onto the front passenger seat, it was possible to unseat a component called the buckle status switch (switch) from the seat belt buckle. If the switch becomes unseated, the front passenger occupant classification system may mistake the rear-facing child restraint for an unbelted adult occupant, and may not suppress the deployment of the front passenger air bag. Specific campaign details are contained within this handbook.

4LI Condition

The National Highway Traffic Safety Administration (NHTSA) recently conducted a front passenger seat airbag suppression test on a Lexus ES 330 platform vehicle. NHTSA discovered that, when installing certain rear-facing infant child seat bases onto the front passenger seat, it was possible to unseat a component called the buckle status switch (switch) from the seat belt buckle. If the switch becomes unseated, the front passenger occupant classification system may mistake the rear-facing child restraint for an unbelted adult occupant, and may not suppress the deployment of the front passenger air bag.

If this condition were to occur when using a rear-facing child restraint in the front passenger seat, you would be alerted by both the flashing red seat belt warning lamp, and the yellow passenger "Airbag ON" lamp on the vehicle dashboard. In this condition, do not operate the vehicle with a rear-facing child restraint installed in the front passenger seat. In the event of a crash, the force of the rapid inflation of the front passenger airbag can cause death or serious injury to the child if the rear-facing child restraint system is installed on the front passenger seat.

Please note that Lexus recommends that you *never* install a rear-facing child restraint in the front passenger seat, even if the passenger "Airbag OFF" lamp is illuminated. ***The safest place for children is in the rear seat.*** Please refer to the Owner's Manual for additional details.

4LI Repair

The SSC 4LI involves replacing the right front seat belt buckle status switch.

Customer Notification

Notification letters will be sent to the owners of affected vehicles beginning in late December 2004. This letter will advise owners of the need to have the right front seat belt buckle status switch replaced.

SSC and Customer Satisfaction

This Special Service Campaign provides us with an opportunity to demonstrate the Lexus commitment to total customer satisfaction. Lexus requests that dealers use the fundamental principals embodied in the Lexus Covenant when servicing these owners and their vehicles. By implementing the 4LI SSC in an organized and efficient manner, we can nurture our on-going relationships with these customers and strengthen these associations. Throughout the campaign, we need to let our customers know that we are genuinely interested in resolving the matter in a timely fashion with as little inconvenience to them as possible.

Identifying Affected Vehicles

The 4LI Special Service Campaign only applies to specific 2004 to early 2005 ES 330s within the VIN ranges on the following page. Not all vehicles in the VIN ranges are involved in this SSC. No other vehicles before or after this range are to be repaired under the provisions of this SSC.

Model	Year	VIN	
		VDS	Range
ES 330	2004	BA30G	0001015 – 0023605 5000006 - 5055753
	2005	BA30G	0023185 – 0024154 5045822 - 5067460

NOTE: Always consult Dealer Daily or TIS to confirm VIN eligibility and to assure the SSC is applicable. This will verify the vehicle is involved and has not already been completed by another dealer. TMS warranty will not reimburse dealers for repairs conducted on vehicles that are not affected.

Manpower and Facility Requirements

Your dealership must plan carefully to accommodate the additional service volume generated as a result of this SSC. In reviewing your dealership's manpower and facility requirements for this Special Service Campaign, there are several items you need to consider.

- Do you need to develop ways to increase your service capacity?
- Do you need to hire additional support staff for pick-up/delivery, car washes and fuel tank fill-ups?

You will need to hold a meeting with all dealership associates to discuss:

Importance of Lexus customer care for each SSC customer.

Various procedures such as phone inquiries, pick up and delivery, loaners, etc.

Campaign specifics including your dealership's assigned quantity, completion objectives, and technical details.

We recommend that one person at your dealership be designated as the campaign coordinator.

Your District Service and Parts Manager will meet with you to answer your questions and monitor the progress of this SSC.

Tools and Equipment

The following tools and equipment are needed for the repair.

- Standard hand tools
- Torque wrench
- Lexus scan tool

Technical Training

The back of this handbook contains the campaign specific repair procedures. We suggest that all service department staff who will be directly involved in completing the repair or supporting the SSC should review the repair procedures to prepare for this SSC.

Parts

Part Number	Part Description	Qty.
73121-33030	Seat Belt Buckle Status Switch	1

You are encouraged to order only those parts needed to repair vehicles with service appointments. Individual dealer tracking will be done and irregularities in quantity ordering will be passed on to Lexus Area Offices for follow-up and correction. There will be sufficient inventory to accommodate this SSC.

DMS Systems

The labor operation code has been transmitted to your dealership. (See page 12 for opcode). DMS dealer files are automatically updated and no further action should be required.

Planning Your Communication Strategy

It is important that you develop a strategy to communicate effectively. The following are some general statements that can be used when explaining the SSC.

Q1: What is the condition?

A1: The National Highway Traffic Safety Administration (NHTSA) recently conducted a front passenger seat airbag suppression test on a Lexus ES 330 platform vehicle. NHTSA discovered that, when installing certain rear-facing infant child seat bases onto the front passenger seat, it was possible to unseat a component called the buckle status switch (switch) from the seat belt buckle. If the switch becomes unseated, the front passenger occupant classification system may mistake the rear-facing child restraint for an unbelted adult occupant, and may not suppress the deployment of the front passenger air bag.

If this condition were to occur when using a rear-facing child restraint in the front passenger seat, you would be alerted by both the flashing red seat belt warning lamp, and the yellow passenger "Airbag ON" lamp on the vehicle dashboard. In this condition, do not operate the vehicle with a rear-facing child restraint installed in the front passenger seat. In the event of a crash, the force of the rapid inflation of the front passenger airbag can cause death or serious injury to the child if the rear-facing child restraint system is installed on the front passenger seat.

Please note that Lexus recommends that you **never** install a rear-facing child restraint in the front passenger seat, even if the passenger "Airbag OFF" lamp is illuminated. ***The safest place for children is in the rear seat.*** Please refer to your Owner's Manual for additional details.

Q2: What is the function of the seat belt buckle status switch?

A2: The buckle status switch located on the seat belt buckle, detects whether the seat belt is fastened or unfastened.

Q3: What is the cause of this condition?

A3: If the child seat base is installed onto the front passenger seat with excessively high belt

and the right front seat cushion height setting could deflect the seat belt buckle from its normal position. As a result, the switch retaining clip could release, and the switch could disengage from the buckle.

Q4: Are there any warnings that this condition exists?

A4: Yes, if this condition were to occur the driver would be alerted by a flashing red seat belt warning light and the yellow passenger "Airbag ON" light located on the dash.

Q5: Which and how many vehicles are involved?

A5: Certain 2004 to early 2005 model year ES 330s vehicles. Also certain 2004 to early 2005 model year Toyota Camry vehicles equipped with a right front power seat are involved. There are approximately 81,000 ES 330 vehicles and 68,000 Camry (TMC and TMMK production) involved in the U.S.

Q6: What is the production period of the affected vehicles?

A6: The affected Lexus ES 330 vehicles were produced from July 2003 through September 2004.

Q7: Are there any other Toyota or Lexus vehicles involved?

A7: Yes, this condition also affects certain 2004 to early 2005 model year Camry vehicles.

Q8: How many incidents of this condition have been reported?

A8: There have been no cases reported for this condition in the affected vehicles.

Q9: Have there been any accidents reported?

A9: There have been no reported cases of accidents related to this condition.

Q10: What is Lexus going to do?

A10: Owners of the involved vehicles will receive a Special Service Campaign notification by first class mail beginning in late December, 2004.

Lexus dealers will replace the right front seat belt buckle status switch at **NO COST** to the vehicle owners.

Q11: How long will the repair take?

A11: The repair will take approximately one hour. However, depending upon the dealer's work schedule, it may be necessary to make the vehicle available for a longer period of time.

Q12: What should an owner do if they experience the condition?

A12: Owners are requested to contact their local Lexus dealer for diagnosis and repair.

Calls to Your Customers

- Customers **involved** in the SSC
 - ⇒ Each affected vehicle owner will receive a notification letter. Please let them that this Special Service Campaign is being undertaken by Lexus to keep their confidence in the Lexus brand.

- Customers **not involved** in the SSC
 - ⇒ Assure any customers with vehicles outside of the involved VIN ranges that this repair is not needed.

Calls from Your Customers

It is important to institute a system to respond to customers calling for more information regarding the SSC. We recommend designating an individual to answer these inquiries to ensure that callers get accurate, consistent information.

Calls from the Media

We ask that you refer any calls from the media or government agencies directly to Lexus headquarters in Torrance, California. The contact at Lexus is:

Bill Ussery, Lexus Public Relations Manager

IMPLEMENTING THE 4LI SSC

Car Rental and Service Loaners

One of the ways we can demonstrate that Lexus cares is by honoring loaner car requests with the best loaner available for those customers unable or unwilling to wait for this repair.

Lexus Customer Convenience System (LCCS)

Officially enrolled LCCS vehicles may be claimed at a rate of \$44.00 per day. (Lexus vehicles only)

Lexus Dealer Fleet (Lexus vehicles only)

A rate of \$44.00 per day may be claimed if using this option. Be sure to follow customer supplied insurance guidelines.

The motivating factor for any of these options is the customer's convenience and consideration. Again please provide the best available vehicle. If extraordinary customer requests are made, please contact your DSPM. In addition, **loaner car requests that exceed one day must carry proper DSPM authorization.**

Remote Area Service Plan

"Remote" is defined as those distances where a customer is 100 or more miles from the nearest Lexus dealership. Your DSPM will work with you to develop and authorize an action plan.

Guidelines to be used in performing remote repairs are:

- If the customer is within 100 miles of the nearest Lexus dealership, the closest Lexus dealership will perform the repair provided that prior authorization for related expenses has been approved by the DSPM.
- If the customer is more than 100 miles from the nearest Lexus dealership, Lexus area associates or, Lexus national associates may perform the repair.

Dealerships may also make these repairs but only with the authorization of the Area Coordinator (most likely the F.T.S.).

- Each situation will be handled on a case-by-case basis.
- Lexus will only pay for authorized costs that have been approved by DSPM or area offices.
- Alternatives include pick-up and redelivery of remotely located vehicles.

The Service Write-Up

Listed below are some general guidelines to use when the customer arrives at your dealership for the SSC:

- Explain that the repair will take about one hour. Inform the customer that the special services (refueling, car wash) will require additional time at your dealership.
- Explain the type of repair involved.
- If the customer does not have an SSC notice:
 - Check the VIN against the national Service History File to see if the vehicle has been previously repaired under this Campaign.
 - Check the left front door hinge post for an SSC completion label.
 - If the vehicle falls outside of the above guidelines, explain that the vehicle does not require the Campaign repairs.
 - If the vehicle is eligible, explain the SSC to the customer; describe the procedure and the amount of time needed for the repair.
- If the customer has an appointment, pull the work order; otherwise, create a work order reflecting the need to complete the SSC 4LI repair.
- Issue the work order to the technician and include job instructions for the SSC.

Preparing for the Delivery After SSC Completion

- Wash/clean the vehicle inside and out.
- Fill the gas tank with the specified unleaded fuel
- Notify customer of completion and arrange for re-delivery or return of rental vehicle.

**Delivery of the Vehicle
After the SSC
Completion**

The delivery of the vehicle is a very important part of ensuring a high level of customer satisfaction. Explain all SSC repairs to the customer and apologize for any inconveniences. Thank the customer for his or her time and their continuing patronage.

Follow-Up

Complete 100% after-service follow-up is critical to ensure complete customer satisfaction with the repairs performed and the service provided.

**Work Order Closing/
Claim Submission**

The following information explains the policies and procedures for preparation and submission of a warranty claim for reimbursement of a repair performed under the SSC 4LI.

Repair	Claim Type	Opcode	Labor Hours*	Sublet
Replace right front seat belt buckle status switch	SC	4630L1	0.7	GA (fuel), TW (tow), RT (loaner vehicle), DE (pick-up and delivery or remote repair), or CW (car wash) as required and substantiated by invoices

* Includes 0.1 labor hours for administrative time.

NOTE: Lexus warranty will only accept one claim per vehicle under the terms of the SSC. Please ensure that your dealership checks the National History File to see if the vehicle has been repaired under this SSC prior to servicing the vehicle.

Recap of Claim Submission and General Provisions of the SSC

- Lexus will pay for gas tank fill-up (actual cost)
- Lexus will pay for washing the vehicle (not to exceed \$20 per vehicle)
- Lexus will provide a loaner vehicle if required (DSPM authorization required for more than one day)
- Lexus will pay for costs associated with remote repairs if required
- Lexus will pay for remote pick-up and delivery if required (DSPM authorization only)

Claiming Reimbursement for Special Services

You must use sublet to claim any special services required in conjunction with the SSC repair.

- Issue **“TW”** (Tow Vehicle)
 - Applicable to every vehicle if required
 - Claim actual receipt amount as a sublet
- Issue **“RT”** (Rental)
 - Applicable to every vehicle if required
 - The loaner vehicle reimbursement rate cap is **one day** per repair unless otherwise authorized by DSPM
- Issue **“GA”** (Gas Tank Fill-Up)
 - Applicable to every vehicle
 - Claim actual fill-up amount
- Issue **“CW”** (Car Wash/Administrative Time)
 - Applicable to every vehicle
 - Amount not to exceed \$20.00 per vehicle
- Issue **“DE”** (Pick-Up and Delivery/Remote Repairs)
 - Applicable only under special circumstances (e.g. more than 100 miles from the nearest Lexus dealership)
 - Claim actual dealer cost

Claim actual dealer cost

F.T.S/A.O.M. authorization is required for this expense

- Issue “**DE**” (**Pick-Up and Delivery/Remote Repairs**)
Applicable at dealer discretion
Claim actual dealer cost

Claim Preparation Instructions

NOTE: Each sublet must be a separate entry with:

- Unique invoice number
- Description
- Sublet Type
- Dollar Amount

**2004 to early 2005 Model Year ES 330
Special Service Campaign 4LI –Right Front Seat Belt Buckle Status Switch**

Dear Lexus Owner:

Thank you very much for your patronage of Lexus. We are dedicated to providing vehicles of outstanding quality and value. As part of our continuing efforts to provide superior customer satisfaction, Lexus is announcing a Special Service Campaign Program on 2004 to early 2005 model year ES 330 vehicles.

What is the condition?

The National Highway Traffic Safety Administration (NHTSA) recently conducted a front passenger seat airbag suppression test on a Lexus ES 330 platform vehicle. NHTSA discovered that, when installing certain rear-facing infant child seat bases onto the front passenger seat, it was possible to unseat a component called the buckle status switch (switch) from the seat belt buckle. If the switch becomes unseated, the front passenger occupant classification system may mistake the rear-facing child restraint for an unbelted adult occupant, and may not suppress the deployment of the front passenger airbag.

If this condition were to occur when using a rear-facing child restraint in the front passenger seat, you would be alerted by both the flashing red seat belt warning lamp, and the yellow passenger "Airbag ON" lamp on the vehicle dashboard. In this condition, do not operate the vehicle with a rear-facing child restraint installed in the front passenger seat. In the event of a crash, the force of the rapid inflation of the front passenger airbag can cause death or serious injury to the child if the rear-facing child restraint system is installed on the front passenger seat.

Please note that Lexus recommends that you *never* install a rear-facing child restraint in the front passenger seat, even if the passenger "Airbag OFF" lamp is illuminated. ***The safest place for children is in the rear seat.*** Please refer to your Owner's Manual for additional details.

What will Lexus do?

Any Lexus dealer will replace the front passenger seat inner seat belt buckle status switch with an upgraded one at **NO COST** to you.

This offer is only available from your local Lexus dealer.

What should you do?

Contact any Lexus dealer and make an appointment to replace the buckle status switch with an upgraded one as soon as possible.

The actual repair will take approximately one hour. However, depending upon the dealer's work schedule, it may be necessary to make your vehicle available for a longer period of time.

Please present this notice to the dealer at the time of your service appointment.

If you no longer own the vehicle, please indicate so on the enclosed postage-paid form, providing us with the name and address of the new owner.

What if you have any other questions?

Please contact any Lexus dealer or call the Lexus Customer Assistance Center at 1-800-255-3987.

We have sent this notice in the interest of your continued satisfaction with our products, and we sincerely regret any inconvenience this condition may have caused you.

Sincerely,

LEXUS DIVISION
TOYOTA MOTOR SALES, U.S.A., INC.

TECHNICAL INSTRUCTIONS
FOR
SPECIAL SERVICE CAMPAIGN 4LI
2004-2005 ES 330
RIGHT FRONT SEAT BELT BUCKLE STATUS SWITCH REPLACEMENT

I. OPERATION FLOW CHART

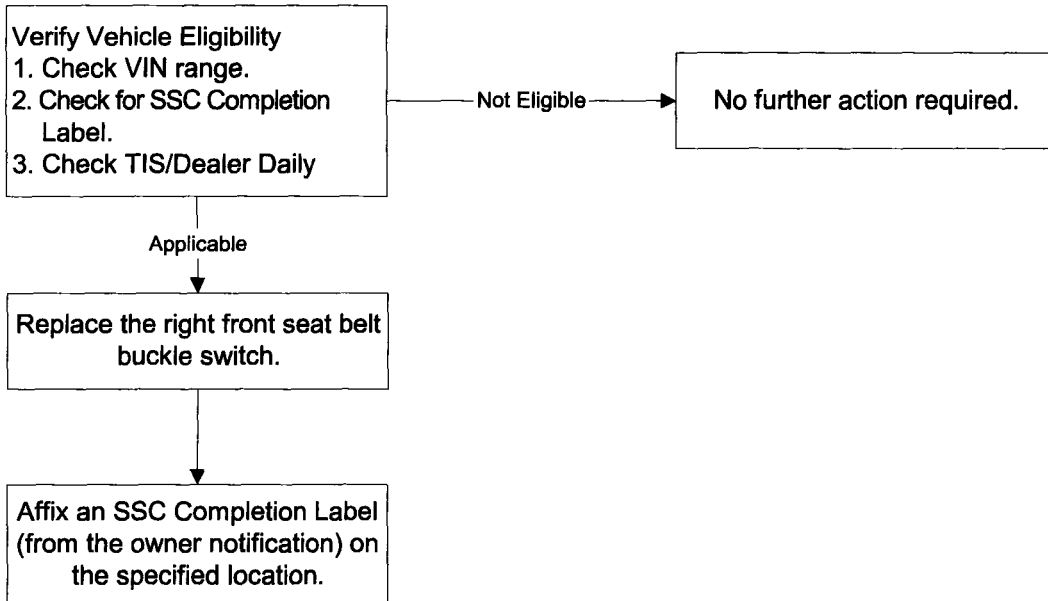

II. IDENTIFICATION OF AFFECTED VEHICLES

A. AFFECTED VIN RANGE

Model	Year	VIN Range	
		VDS	Ranges
ES 330	2004	BA30G	0001015 – 0023605 5000006 – 5055753
	2005	BA30G	0023185 – 0024154 5045822 – 5067460

NOTE: Not all vehicles in the VIN range are affected by this SSC. Always consult Dealer Daily or TIS to confirm VIN eligibility and to assure the SSC is applicable. This will verify the vehicle is involved and has not already been completed by another dealer. TMS warranty will not reimburse dealers for repairs conducted on vehicles that are not affected.

III. PREPARATION

A. PARTS

Part No.	Parts Name	Q'ty/ Vehicle
73121-33030	Seat Belt Buckle Status Switch	1

B. TOOLS

- Standard hand tools
- Torque wrench
- Lexus scan tool

C. COMPONENTS

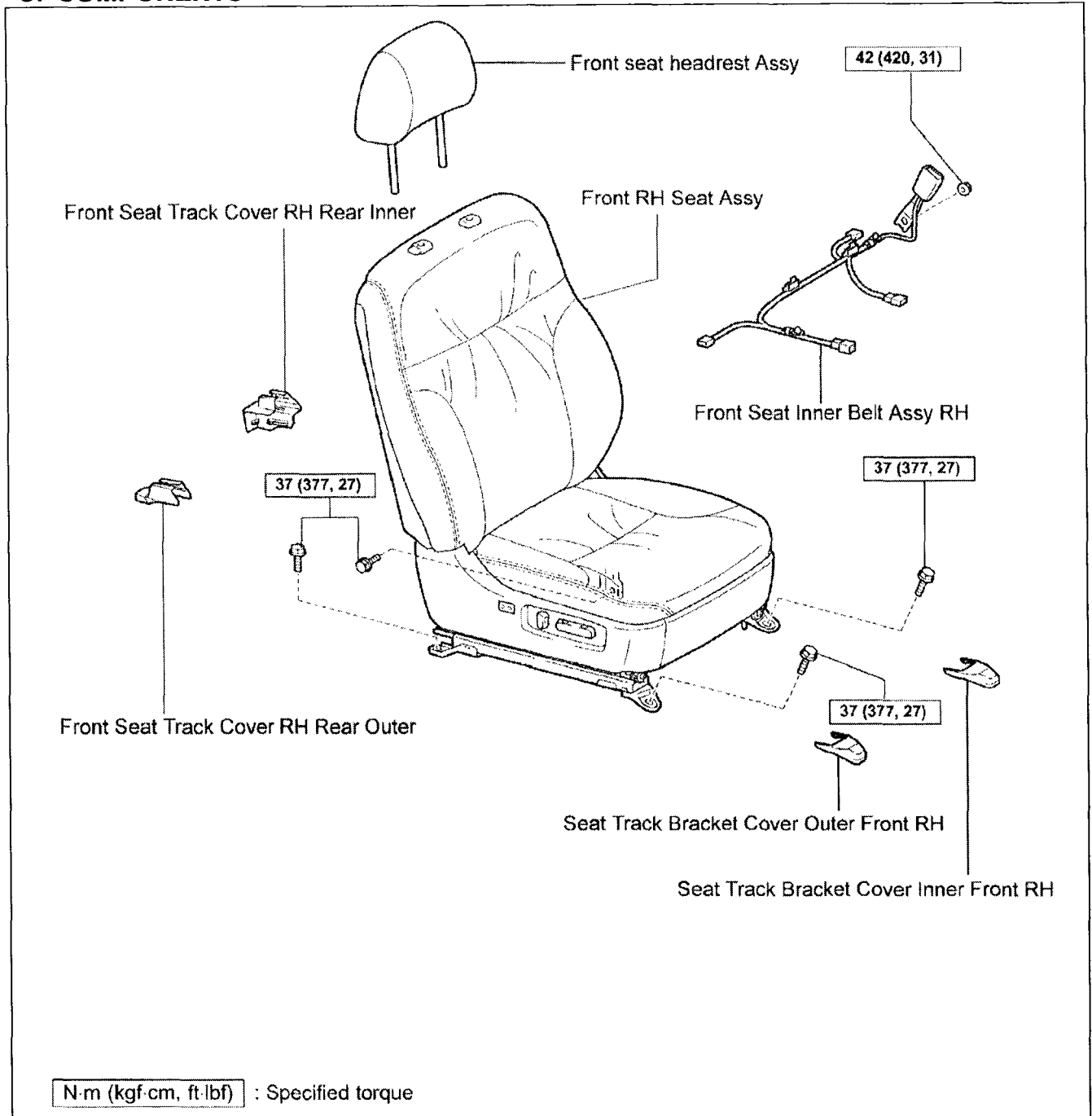

IV. WORK PROCEDURE

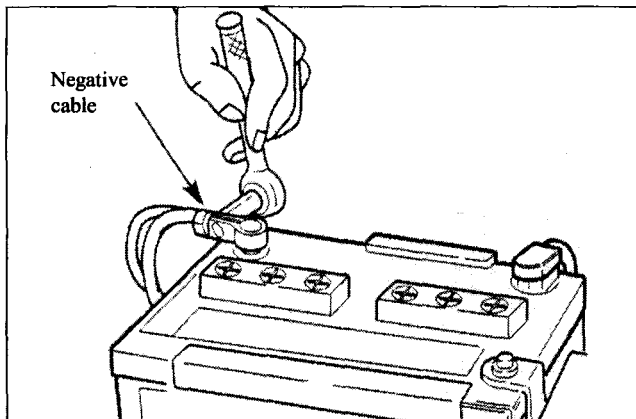
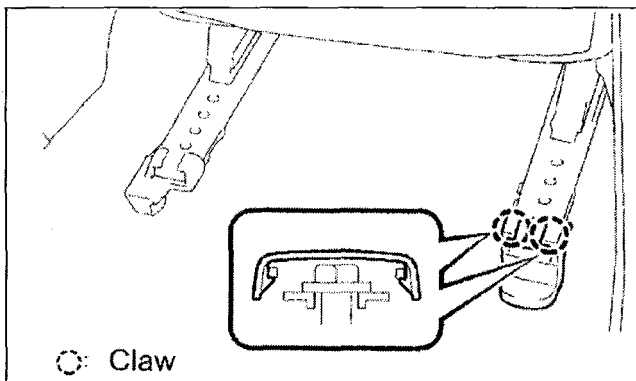
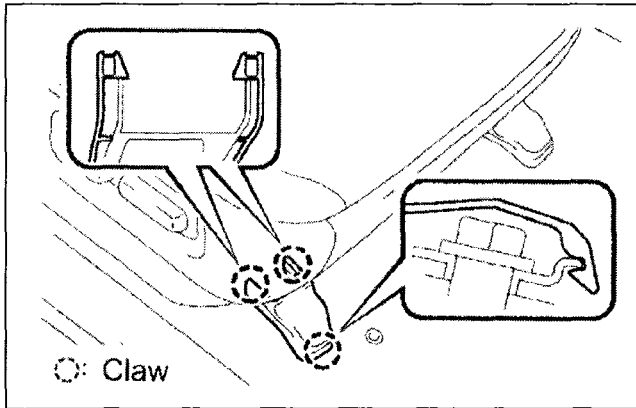

1. **REMOVE THE RIGHT FRONT SEAT**
 - (a) Remove the headrest.
 - (b) Place the backrest in the upright position.
 - (c) Move the seat fully to the rear.
 - (d) Disengage the 3 claws for the front outer seat track cover.
 - (e) Remove the seat track cover.
 - (f) Remove the front inner seat track cover.
 - (g) Remove the 2 front seat bolts.
 - (h) Move the seat fully forward.
 - (i) Disengage the 2 claws for the outer seat track cover.
 - (j) Remove the seat track cover.
 - (k) Remove the rear inner seat track cover.
 - (l) Remove the 2 rear seat bolts.
 - (m) Record audio station presets.
 - (n) Disconnect the negative battery cable.

NOTE:

Wait a minimum of two minutes before working on any part of SRS system. This allows the SRS reserve system to power down.

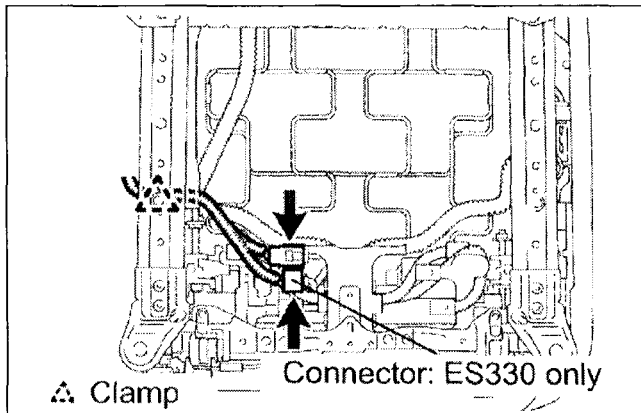

- (o) Disconnect the clamp and the 2 connectors located under the seat.
- (p) Disconnect the clamp and connectors for the power seat motors and SRS system.

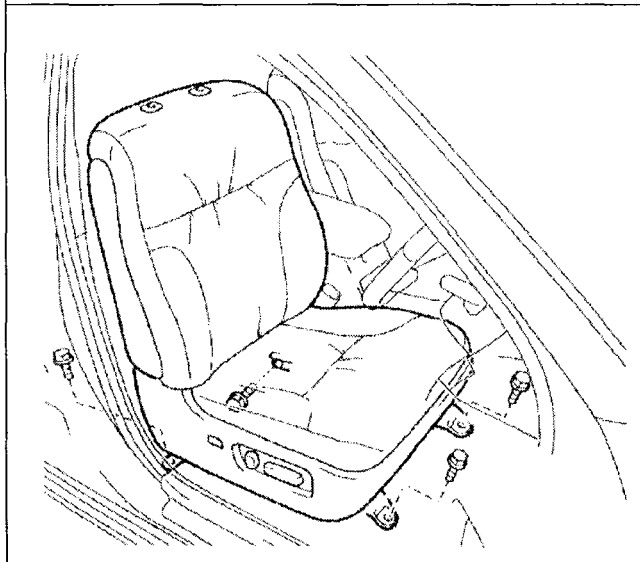

- (q) Remove the seat.

NOTE:

The yaw sensor is mounted to the floor under the right front seat and could be damaged during seat removal and installation.

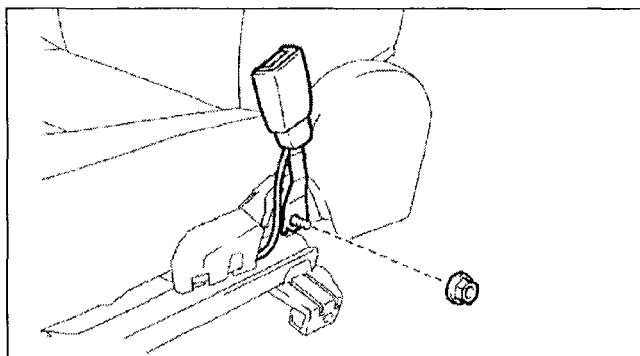

2. REPLACE THE SEAT BELT BUCKLE SWITCH

- (a) Remove the seat belt buckle nut.
- (b) Remove the seat belt buckle.

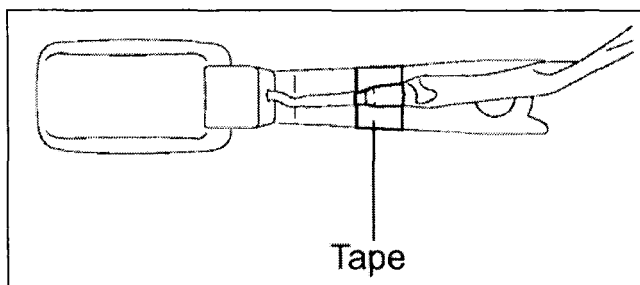

- (c) Remove the tape holding the wire harness to the buckle.

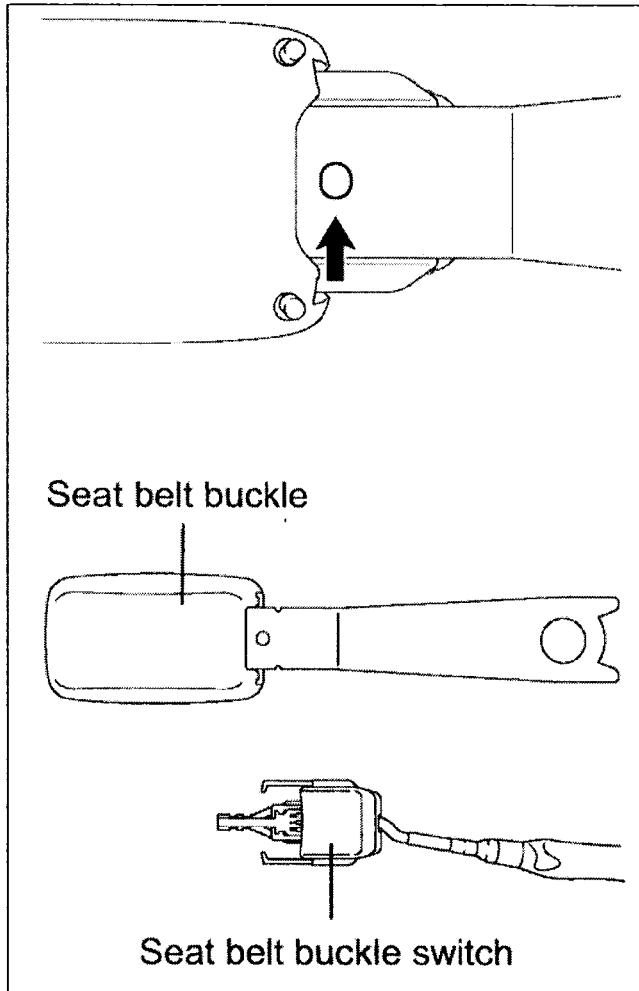

- (d) Using a small pin punch, release the clip holding the switch assembly to the buckle.
- (e) Remove the switch assembly from the buckle.

NOTE:
Pull the switch straight back from the buckle.

Claw Inserting Positions:

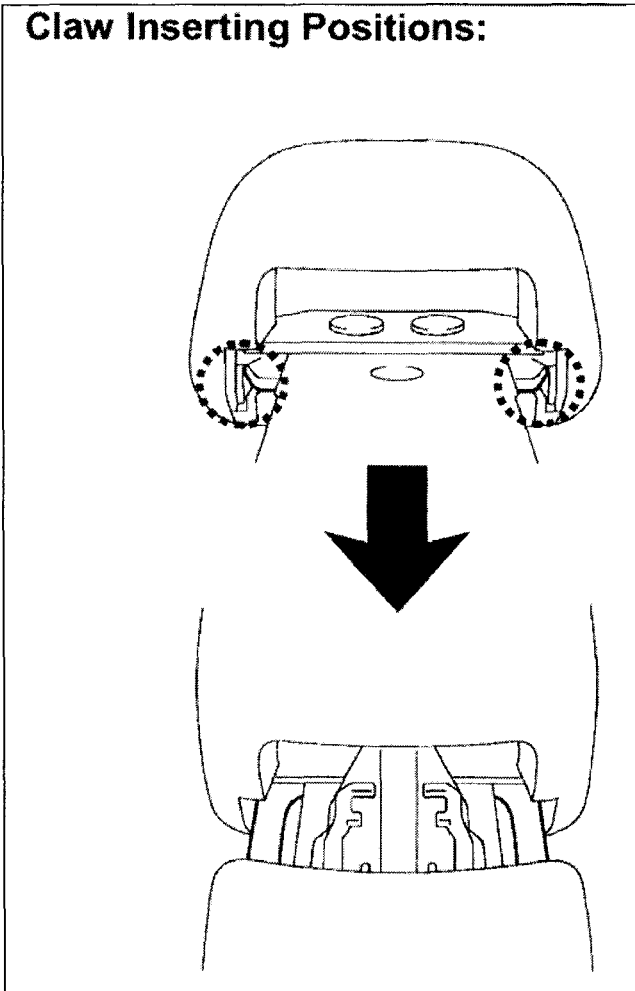

(f) Install the new switch assembly into the buckle.

NOTE:

Ensure that the new switch assembly engages into the buckle. There will be an audible click when the switch is correctly engaged into the buckle.

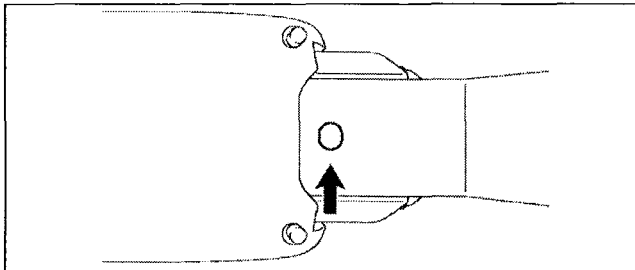

(g) Ensure that the tab is securely inserted into the hole in the seat belt buckle.

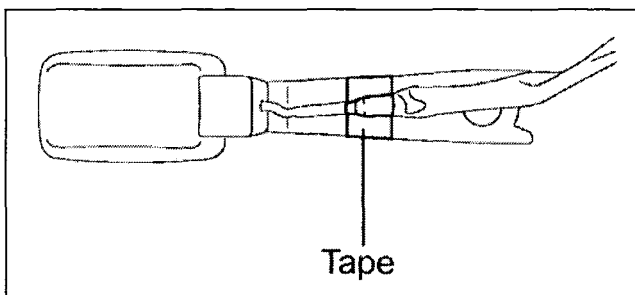

(h) Re-tape the harness to the buckle as shown.

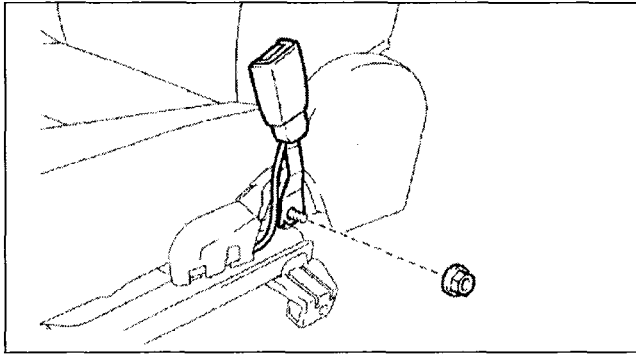

- (i) Reinstall the seat belt buckle.
- (j) Reinstall the nut.

Torque:
42N·m (420 kgf·cm, 31 ft·lb)

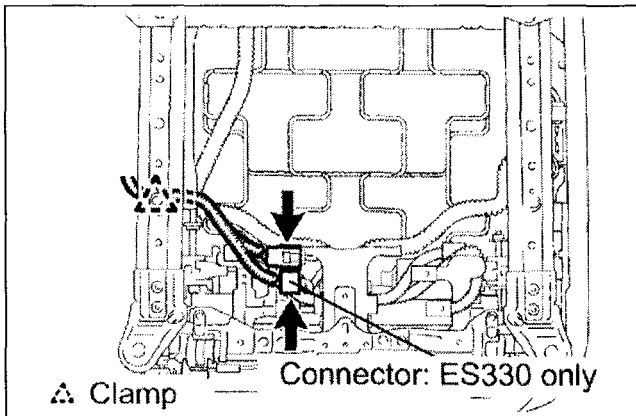

3. REINSTALL THE RIGHT FRONT SEAT

- (a) Reinstall seat into the vehicle.
- (b) Reconnect the 2 connectors and the clamp.
- (c) Reconnect the clamp and connectors for the power seat motors and SRS system.

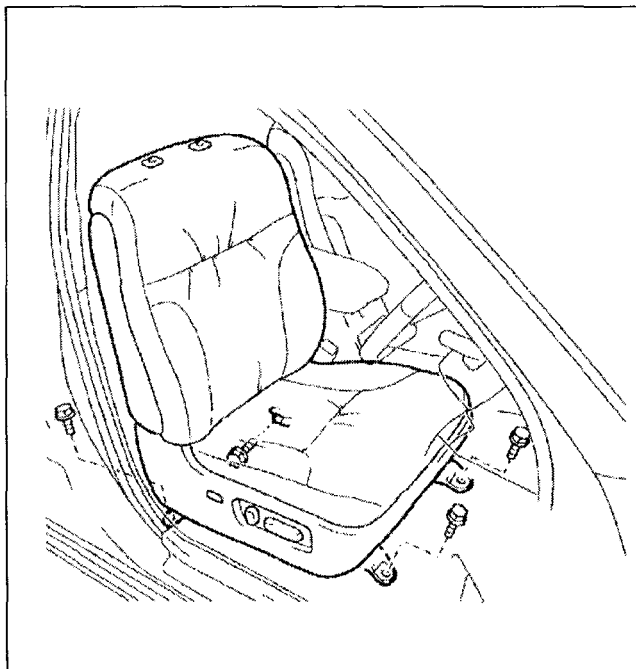

- (d) Reconnect the negative battery terminal.
- (e) Move the seat fully to the rear.
- (f) Reinstall the 2 front seat bolts.

Torque:
37N·m (377 kgf·cm, 27 ft·lb)

- (f) Reinstall the 2 front seat track covers.
- (g) Move the seat fully forward.
- (h) Reinstall the 2 rear seat bolts.

Torque:
37N·m (377 kgf·cm, 27 ft·lb)

- (i) Reinstall the 2 rear seat track covers.
- (j) Reinstall the headrest.

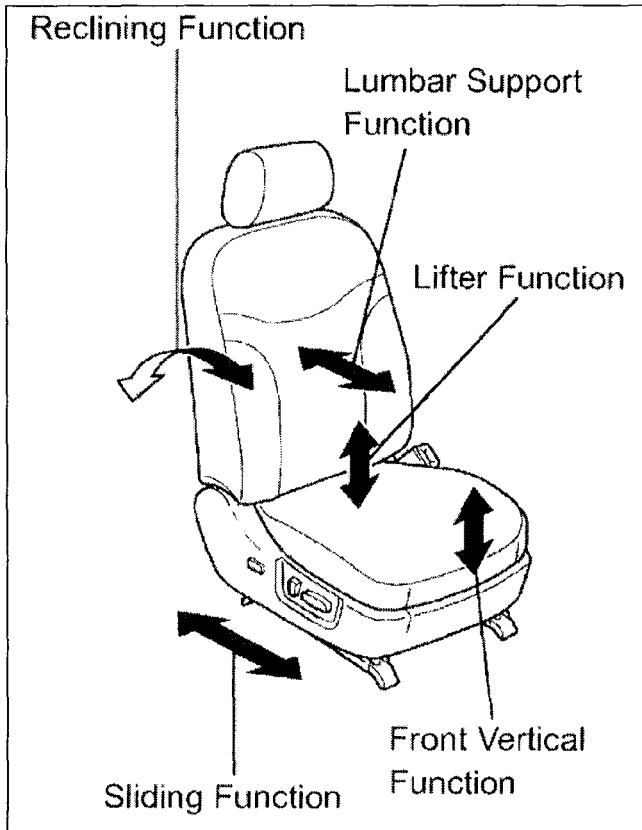

- 4. INSPECT POWER SEAT OPERATION**
- (a) Using the power seat controls, check that the following seat functions operate properly:
- Fore and aft movement
 - Front vertical
 - Lifter
 - Backrest recline
 - Lumbar support (if equipped)
 - Seat heater (if equipped)

5. INITIALIZE THE FRONT RIGHT FRONT SEAT OCCUPANT CLASSIFICATION SYSTEM

NOTE:
 The zero point calibration and sensitivity check must be preformed after this repair has been completed. Refer to the appropriate repair manual for front passenger seat initialization.

V. SSC COMPLETION LABEL INSTALLATION

After completing the repair and before returning the vehicle to the owner, an SSC completion label, which is enclosed in the owner's notification, must be affixed to the left front door hinge post, near the check strap.

(a) The label is to be filled out as follows:

- Write in SSC 4LI.
- Write in date of repair.

SSC	Date
DEALER CODE NO.	
00410-01917	

- Write in your dealer code.
- (b) Additional SSC completion labels, in sheets of 50 (P/N 00410-01917), may be ordered through the non-parts application on your DMS system.