

c/o Subaru of America
Subaru Plaza
P.O. Box 6000
Cherry Hill, NJ 08034-6000
856-488-8500
Fax 856-488-9279

Brian DeAscentis
Campaign Administrator
Direct Dial: (856) 488-3485
Fax: (856) 488-8869
E-mail: bdeascentis@subaru.com

July 1, 2004
Ref. No.: 04V-274

Patricia Wallace
Recall Management (NVS-215)
National Highway Traffic Safety Administration
400 Seventh Street, S.W.
Washington, D.C. 20590

RE: Part 573.6(c)(9) – Subaru Legacy Sedan & Outback Sedan Side Curtain Airbag Recall
WWR-02

Dear Ms. Wallace,

Pursuant to the requirements in 49 CFR Part 573.6(c)(9), Subaru of America, Inc. ("Subaru") submits the following communications relating to the above recall:

Subaru Dealer Announcements	
WWR-02 Press Release	6/4/2004
WWR-02 Recall Update – Dealer Letter	6/7/2004
WWR-02 Recall Update – Repair Instructions	6/7/2004
WWR-02 Recall Bulletin	6/8/2004
WWR-02 Part Number Application Notice	6/8/2004
WWR-02 Old Part Return Announcement	6/9/2004
WWR-02 Claim Submission Reminder	6/17/2004
WWR-02 Old Part Return Procedure	6/21/2004
WWR-02 Revised Recall Bulletin (labor change)	6/25/2004
WWR-02 Updated Labor Time Announcement	6/28/2004

If there are any questions about this report, please contact me at (856)-488-3485.

Sincerely,



Brian DeAscentis
Campaign Administrator

Enclosures

RECEIVED
JUL 1 2004
NHTSA
NVS-215

Posted on Subarunet 6-7-04

SUBARU

June 7, 2004

Dear Subaru Dealer:

We want to update you of the voluntary recall for a defect in the side curtain airbags. This recall affects approximately 1,960 early production 2005 Legacy Sedan and Outback Sedan vehicles. Approximately 130 of the affected vehicles have been retailed.

The affected vehicles comply with the current side impact requirements of the Federal Motor Vehicle Safety Standards 201P and 214D. However, the newly designed side curtain airbags on the affected vehicles were not built to proper Fuji Heavy Industries Ltd. specifications, which provide added occupant head protection and therefore, may not offer proper head protection in side impact crashes. There have been no accidents or injuries attributed to this problem.

We have assigned campaign code WWR-02 to the Side Curtain Airbag Recall.

The affected VIN range for this recall is 2005MY Legacy Sedan / Outback Sedan 4S*BL***5*200001 - 204811. Not all vehicles within the affected range are affected. Each dealer was provided a list of affected vehicles in their inventory by their Region / Distributor Office. Coverage and control numbers for this campaign will be available through the Dealer Communication System (DCS) vehicle coverage inquiry on June 9th. Before proceeding with repairs, verify coverage for any vehicle found to be within the affected VIN range that is not found on your dealer list.

Repair instructions will be available on Subarunet on June 7th.
Claim instructions will be available on Subarunet on June 8th.

Replacement parts for retailed vehicles will be sent directly to dealers during the week of June 7th. Parts for inventoried vehicles will be sent as they become available. Dealers should have all necessary parts to repair inventory vehicles by June 18th.

Subaru will notify all owners of the 130 retailed vehicles by telephone and by first class mail as soon as the replacement parts arrive at dealers.

Dealers with affected vehicles in inventory will be reimbursed floor plan expenses for those vehicles.

Thank you for your cooperation in this matter.

Subaru of America, Inc.

Posted on SubaruNet on June 4, 2004

1

News & Information

SUBARU

Subaru of America, Inc.
Subaru Plaza
P.O. Box 8000
Cherry Hill, NJ 08034-8000
856.488.8500
www.media.subaru.com

FOR IMMEDIATE RELEASE

**SUBARU OF AMERICA, INC. ANNOUNCES VOLUNTARY RECALL OF
2005 LEGACY SEDANS AND OUTBACK SEDANS
– Campaign to address side curtain airbag problem –**

CHERRY HILL, N.J., June 4, 2004 – Subaru of America, Inc. today announced a voluntary recall on 2005 Legacy Sedan and Outback Sedan models to address a side curtain airbag problem.

This recall involves all 2005 model year Subaru Legacy Sedan and Outback Sedan models. The affected vehicles were produced at Subaru of Indiana Automotive, Inc. between October 2, 2003 and June 1, 2004. While approximately 1,960 vehicles are affected, only 130 vehicles have been retailed.

The affected vehicles comply with the current side impact requirements of the Federal Motor Vehicle Safety Standards 201P and 214D. However, the newly designed side curtain air bags on the affected vehicles were not built to proper Fuji Heavy Industries Ltd. specifications, which provide added occupant head protection and therefore, may not offer proper head protection in side impact crashes. There have been no accidents or injuries attributed to this problem.

In early June, Subaru will notify all owners of the 130 retailed vehicles by telephone and by mail to return their vehicles to a Subaru dealer for installation of new side curtain air bags at no charge to the owner.

About Subaru of America, Inc.

Subaru of America, Inc. is a wholly-owned subsidiary of Fuji Heavy Industries Ltd. of Japan. Headquartered in Cherry Hill, N.J., the company markets and distributes all-wheel drive Subaru vehicles, parts and accessories through a network of nearly 600 dealers across the United States. Subaru is the only car company that features Symmetrical All-Wheel Drive as standard equipment on every vehicle in its product line. For additional information please visit www.subaru.com.

###

Posted on SubaruNet 6-7-04

ATTENTION:
GENERAL MANAGER PARTS MANAGER
CLAIMS PERSONNEL SERVICE MANAGER
IMPORTANT - All Service Personnel Should Read and Initial

SUBARU ★

Service Procedure for replacing Side Curtain Air Bags

Tools & Equipment Needed:

1. Clip Tool
2. ¼" Drive 10mm Socket
3. ¼" Drive Ratchet
4. ¼" Drive 6" Extension
5. #2 Phillips Screw Driver
6. Small Mini Screwdriver and/or Plastic Trim Stick
7. Air/Battery Gun or Ratchet
8. Torque Wrench (capable of 5.5 ft.lb spec or 66 in.lb)
9. 10mm Open End Wrench
10. Vacuum Cleaner
11. Protective Covers for Seat, Door Pad, and Instrument Panel
12. Disposable Gloves

NOTE: Before beginning, ensure your clothing and hands are free from dirt and grease. Find a clear and clean area to lay removed trim parts to avoid dirt getting on these parts.

The reverse side of the Headliner Trim Panel has a pressed fiberglass layer. The residue from this layer may cause irritations to the skin and may leave dust inside the interior of the vehicle. Please wear protective gloves to keep fiberglass away from skin and to keep trim clean. Remove gloves after retrofit is complete and thoroughly vacuum the entire interior of the vehicle.

Disassembly

Use extreme care when removing, positioning and storing trim parts to avoid damaging them. Be careful to keep all interior parts clean. Pay close attention to the original position of all trim panels and weather strips to maintain fit & finish.

1. Open hood and all doors. Lower all windows.
2. Record radio stations.
3. Disconnect "Negative" Battery Cable from Battery Terminal.
 - Be careful not to touch Battery Cable to metal objects.
 - Be careful of Battery Terminal grease.

continued...

4. Remove the A-Pillar upper trim covers. Start by pushing the metal tab with a flat blade screwdriver or similar tool to release the top portion. Next, gently pull on the trim to disengage the lower clip.

Note: If the metal clip is damaged during removal, the A-Pillar trim must be replaced.

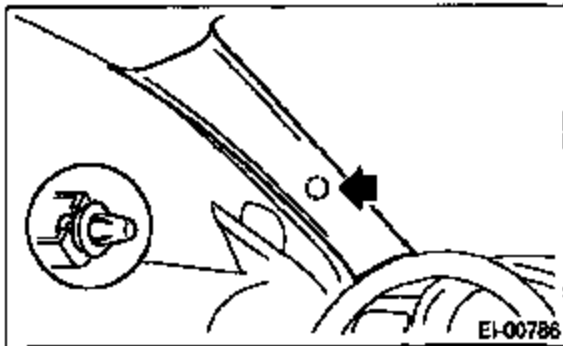
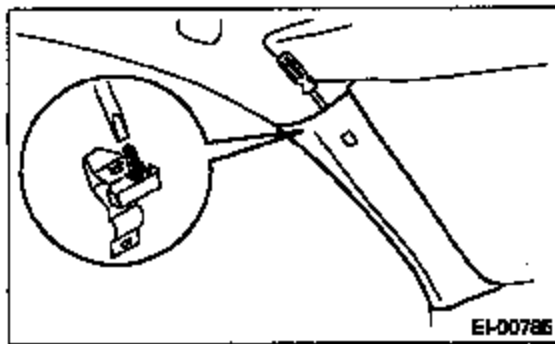

5. Remove the Sun Visors by carefully removing the covers and the mounting screws. If equipped with vanity mirror lights, disconnect the wiring connector. Remove the Sun Visor Hooks by pressing the (A) on both sides, using a flat tip screwdriver and pulling the hook towards you.

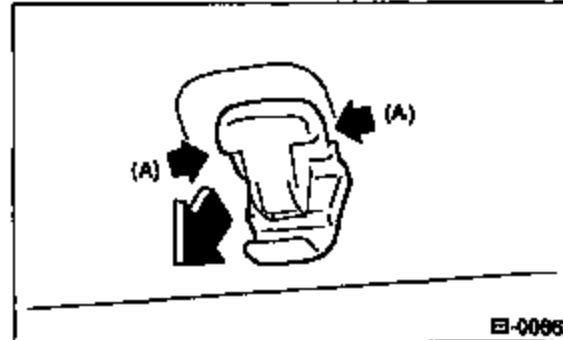

6. Remove the Map Light Lens, Map Light Screws, and disconnect all wiring connectors. If equipped, disconnect wiring connector for Sun Roof.
7. If equipped, remove the Sun Roof Garnish.

continued...

8. Remove front & rear Assist Grips by carefully removing the covers and screws. Pull the left side of assist grip toward you, and rotate the right side of it counterclockwise to remove.

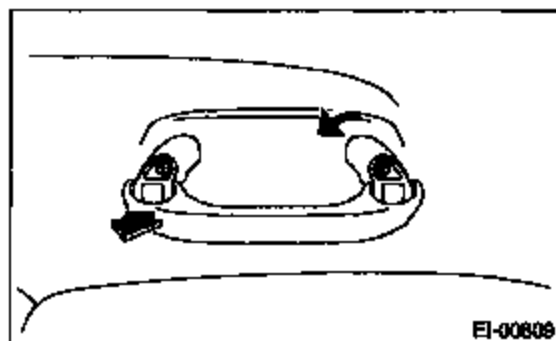

9. Remove B-Pillar lower trim covers (it will stay attached to the Seat Belt) and position it safely out of the way to avoid damaging it or other interior parts.

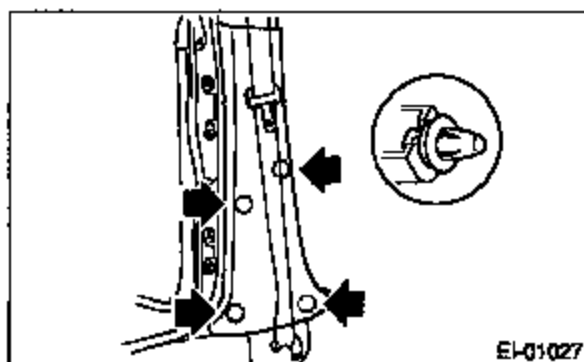

10. Remove B-Pillar upper trim by carefully removing the cap on the upper portion of the pillar trim. Remove the bolt.

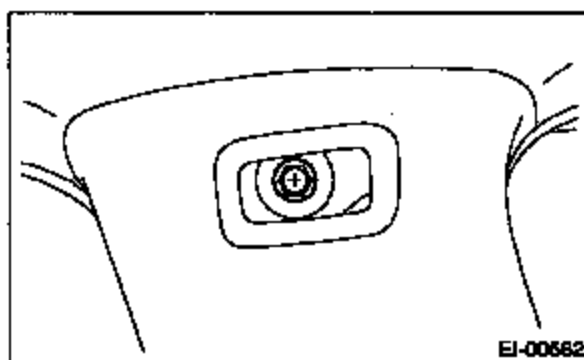

11. Remove center interior Room Light Lens, Room Light, and disconnect wiring connector.

continued...

12. Remove C-Pillar upper trim and trim cover.

(1) Carefully pull on trim cover to gain access to the metal clip. Slide a mini screwdriver under metal tab and push upward to disengage clip. Carefully remove trim cover.

- Removal of this trim can be accomplished without removal of the rear seat, however removal is easier with the rear seat removed.
- If you leave the rear seat installed, to ease removal of upper C-Pillar trim bolts, remove rear seatback Headrests LH/RH and lay aside.

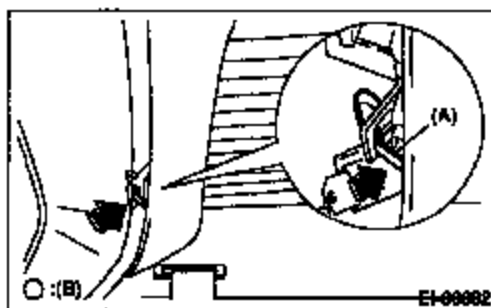

(2) Carefully remove the cap on the upper portion of the C-Pillar trim. Remove the 4 Bolts to remove the trim.

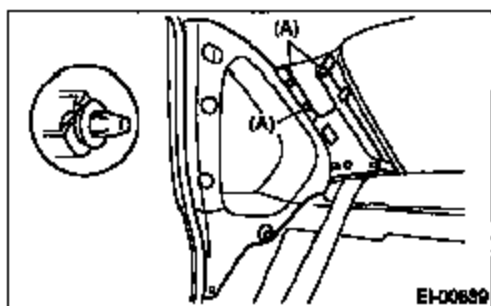

13. Disconnect the antenna lead at the connector located by the driver's side C-Pillar.

14. Reconnect "Negative" Battery cable. (Power Seat equipped vehicles only).

15. Position Front Seats and Seat Back to a position that can provide some support to the Headliner when it is lowered in later steps.

16. Unclip the 3 clips holding the rear of the Headliner near the rear window.

17. Slide Front of Headliner to the passenger side slightly to release the clip in the front of the Headliner. Gently lower the Headliner while releasing any wires from the retaining clips on the Headliner.

18. Disconnect the "Negative" Battery cable from the Battery Terminal.

continued...

Important: Make sure battery is disconnected for at least 30 seconds before moving to next step.

19. Disconnect Side Curtain Air Bag electrical connections (located at the rear end of the Side Curtain Air Bag Assembly).

How to disconnect:

- (1) Push the lock arm (A).
- (2) With the lock arm (A) pushed in, move the slide lock (B) in the direction of arrow.
- (3) With the slide lock moved, release the lock arm (back to its original position), and disconnect the connector.

CAUTION: When pulling the side lock or disconnecting the connector, be sure to hold onto the connector and not the wire.

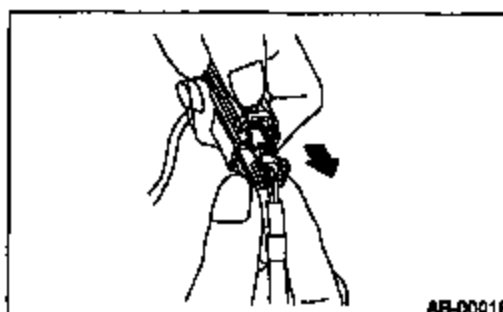
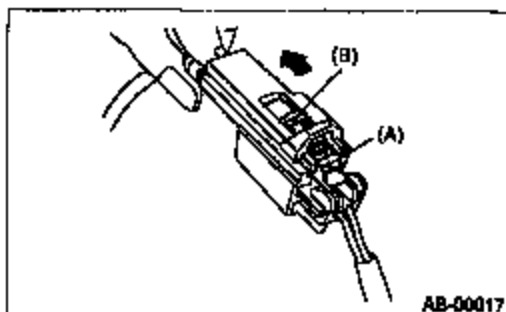

20. Remove both Side Curtain Air Bags -- (9 bolts each side – Sunroof Model); (8 bolts each side – Non Sunroof Model). Remove the bolts (A) and clip (B), and then remove the Side Curtain Air Bag module.

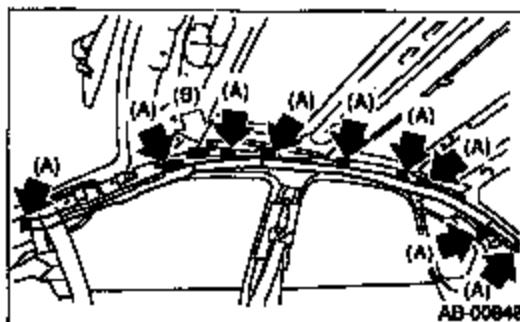

Important:

- Start with the front end of the Side Curtain Air Bag and move towards the rear.
- Be careful not to disturb the routing of the Sun Roof Drain tubes (if equipped).
- Be careful when removing bolts, that the metal brackets which are part of the Side Curtain Air Bag Assembly do not damage seat covers or other interior

continued...

trim parts as they fall to a lower position. You might want to tape or secure a rag to the end brackets for protection.

- Be careful not to mix the Side Curtain Air Bag bolts with other trim part bolts. Use the same bolts for reinstalling the new Side Curtain Air Bag.

Side Curtain Air Bag Installation

NOTE: Retain the packaging that the new Side Curtain Air Bag was shipped in. It will be required for returning the removed parts.

21. Install Side Curtain Air Bag.

- Start with the rear bolts and move forward.
- Torque Side Curtain Air Bag Bolts to 5.5 ft.lb.
- Connect Side Curtain Air Bag electrical connectors.

How to connect:

Holding the connector, push it in carefully until a connecting sound is heard.

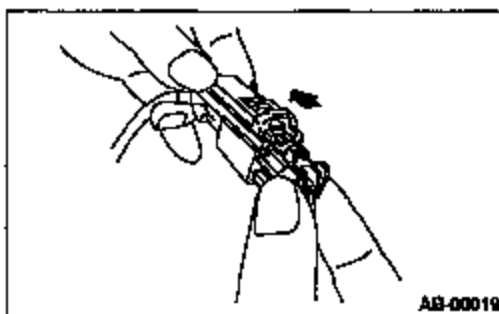

CAUTION: Be sure to insert the connector in until it is locked. Then pull on it gently to make sure that it is locked.

Assembly

Assembly can be accomplished by reversing the order of the disassembly (with the exception of the "Negative" Battery Cable steps, as noted).

22. Vacuum Interior of Vehicle

- Remove gloves before re-entering vehicle to remove all fiberglass residue on Seats, Carpet and Interior Trim, including Instrument Panel.

23. Check operation of interior lighting: Center Room Lamp, Map Lights, and Sun Visor Vanity Lights. Check Sun Roof operation if equipped.

24. Verify Air Bag System operation by turning key on and confirming Air Bag System Warning Lamp goes out after 6 seconds.

25. Reset Radio stations and clock. Verify radio reception.

Posted on Subaru net 6-8-04

ATTENTION:
GENERAL MANAGER PARTS MANAGER
CLAIMS PERSONNEL SERVICE MANAGER
IMPORTANT - All Service Personnel Should Read and Initial

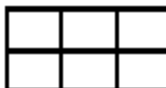

SUBARU

PRODUCT CAMPAIGN BULLETIN

APPLICABILITY: 2005MY Legacy Sedan and
Outback Sedan Vehicles
SUBJECT: Side Curtain Air Bags

NUMBER: WWR-02
DATE: 06/2004

INTRODUCTION

Subaru of America, Inc. (SOA) has determined that affected vehicles, listed below, were produced with a Side Curtain Air Bag that may not fully deploy rapidly enough when activated in a side impact collision.

This recall will involve replacement of both Side Curtain Air Bag modules.

AFFECTED VEHICLES

Affected vehicles are identified in the VIN range chart below. **NOTE: Not all vehicles within the VIN range are affected. Coverage for all affected vehicles must be confirmed by using the Vehicle Coverage Inquiry in the Dealer Communication System (DCS).**

2005MY Legacy Sedan / Outback Sedan	4S*BL****5*200001 - 204811
-------------------------------------	----------------------------

*Note 1. Various characters may occupy the VIN positions identified by "**"*

Note 2. Vehicles identified in the preceding chart may include VINs that were not distributed in the U.S. market. Dealers will be provided a list of VINs that include the owner name and address. This information will enable dealers to follow-up with owners of potentially affected vehicles.

OWNER NOTIFICATION

SOA will contact owners of affected vehicles by telephone when repair parts become available at dealers. A notification letter will also be sent on or around June 14, 2004. A copy of the Owner Notification Letter is included at the end of this bulletin.

continued...



CAUTION: VEHICLE SERVICING PERFORMED BY UNTRAINED PERSONS COULD RESULT IN SERIOUS INJURY TO THOSE PERSONS OR TO OTHERS.

Subaru Service Bulletins are intended for use by professional technicians ONLY. They are written to inform those technicians of conditions that may occur in some vehicles, or to provide information that could assist in the proper servicing of the vehicle. Properly trained technicians have the equipment, tools, safety instructions, and know-how to do the job correctly and safely. If a condition is described, DO NOT assume that this Service Bulletin applies to your vehicle, or that your vehicle will have that condition.

DEALER PROGRAM RESPONSIBILITY

Dealers are to promptly service all vehicles subject to this recall at no charge to the vehicle owner regardless of mileage, age of the vehicle, or ownership.

For affected vehicles sold after the date on the dealer's computer list, dealers are to contact those owners and provide them with a copy of the owner notification letter. They should also arrange to make the required correction according to the instructions in the service procedure section of this bulletin.

VEHICLES IN DEALER INVENTORY

Dealers are also to promptly perform the applicable service procedures defined in this bulletin to correct all affected vehicles in their inventory (new, used, demo). Additionally, whenever a vehicle subject to this recall is taken into dealer new or used inventory, or is in the dealership for service, necessary steps should be taken to ensure the recall correction has been made before selling or releasing the vehicle.

New or used vehicles listed in a recall/campaign that are in dealer stock must be:

- Immediately identified.
- Tagged or otherwise marked to prevent their delivery or use prior to inspection and/or repair.
- Repaired in accordance with the repair procedures outlined in this Product Campaign Bulletin.

Any Authorized Subaru Dealer failing to perform the applicable service procedures defined in this bulletin to correct all affected vehicles in their inventory (new, used, demo) prior to the vehicle being placed in service may be subject to civil penalties of up to \$5,000 per violation (i.e., for each vehicle), as provided in 49 USC §30165(a) of the Safety Act, and will also be in breach of the Subaru Dealer Agreement.

PARTS INFORMATION

Each dealer will automatically be sent a quantity of side curtain airbag modules to repair sold and inventory vehicles.

MODEL	DESCRIPTION	PART NUMBER
Models with Sunroof	Side Curtain Airbag Module (Right side)	98251AG08A
	Side Curtain Airbag Module (Left side)	98251AG09A
Models without Sunroof	Side Curtain Airbag Module (Right side)	98251AG10A
	Side Curtain Airbag Module (Left side)	98251AG11A

continued...

REPAIR PROCEDURES

Tools & Equipment Needed:

1. Clip Tool
2. ¼" Drive 10mm Socket
3. ¼" Drive Ratchet
4. ¼" Drive 6" Extension
5. #2 Phillips Screw Driver
6. Small Mini Screwdriver and/or Plastic Trim Stick
7. Air/Battery Gun or Ratchet
8. Torque Wrench (capable of 5.5 ft.lb spec or 66 in.lb)
9. 10mm Open End Wrench
10. Vacuum Cleaner
11. Protective Covers for Seat, Door Pad, and Instrument Panel
12. Disposable Gloves

NOTE: Before beginning, ensure your clothing and hands are free from dirt and grease. Find a clear and clean area to lay removed trim parts to avoid dirt getting on these parts.

The reverse side of the Headliner Trim Panel has a pressed fiberglass layer. The residue from this layer may cause irritations to the skin and may leave dust inside the interior of the vehicle. Please wear protective gloves to keep fiberglass away from skin and to keep trim clean. Remove gloves after retrofit is complete and thoroughly vacuum the entire interior of the vehicle.

Disassembly

Use extreme care when removing, positioning and storing trim parts to avoid damaging them. Be careful to keep all interior parts clean. Pay close attention to the original position of all trim panels and weather strips to maintain fit & finish.

1. Open hood and all doors. Lower all windows.
2. Record radio stations.
3. Disconnect "Negative" Battery Cable from Battery Terminal.
 - Be careful not to touch Battery Cable to metal objects.
 - Be careful of Battery Terminal grease.
4. Remove the A-Pillar upper trim covers. Start by pushing the metal tab with a flat blade screwdriver or similar tool to release the top portion. Next, gently pull on the trim to disengage the lower clip.

continued...

Note: If the metal clip is damaged during removal, the A-Pillar trim must be replaced.

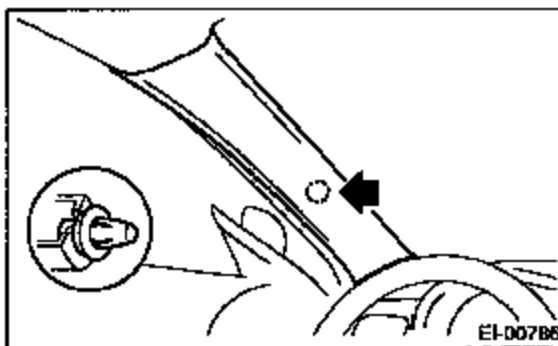
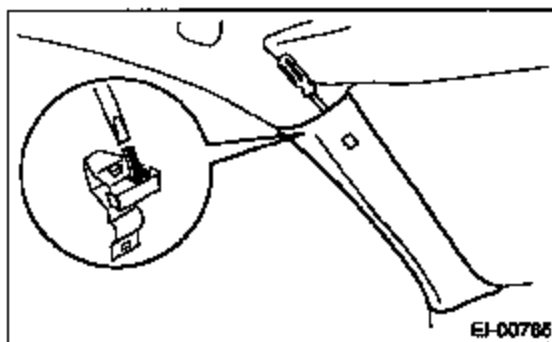

5. Remove the Sun Visors by carefully removing the covers and the mounting screws. If equipped with vanity mirror lights, disconnect the wiring connector. Remove the Sun Visor Hooks by pressing the (A) on both sides, using a flat tip screwdriver and pulling the hook towards you.

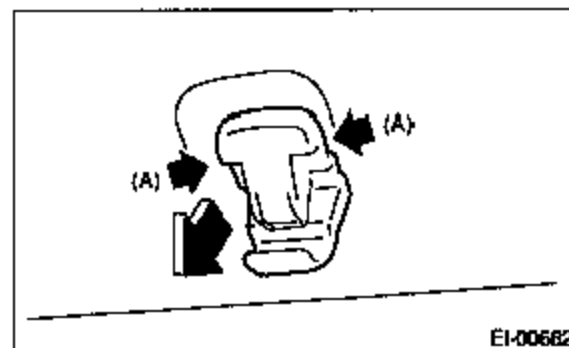
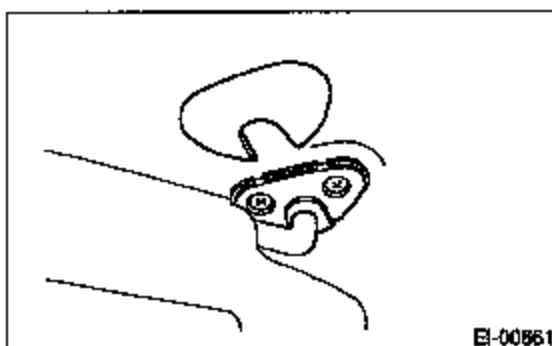

6. Remove the Map Light Lens, Map Light Screws, and disconnect all wiring connectors. If equipped, disconnect wiring connector for Sun Roof.
7. If equipped, remove the Sun Roof Garnish.

continued...

8. Remove front & rear Assist Grips by carefully removing the covers and screws. Pull the left side of assist grip toward you, and rotate the right side of it counterclockwise to remove.

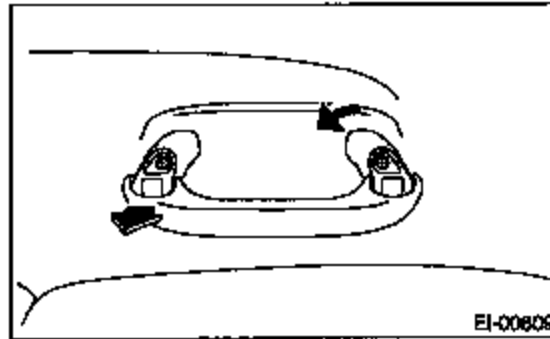

9. Remove B-Pillar lower trim covers (it will stay attached to the Seat Belt) and position it safely out of the way to avoid damaging it or other interior parts.

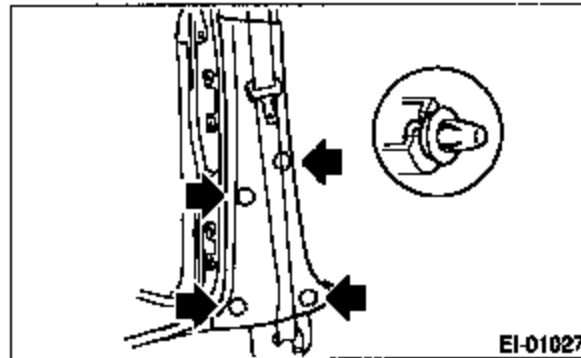

10. Remove B-Pillar upper trim by carefully removing the cap on the upper portion of the pillar trim. Remove the bolt.

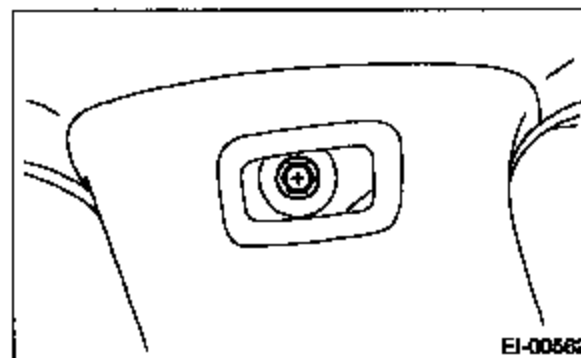

11. Remove center interior Room Light Lens, Room Light, and disconnect wiring connector.

continued...

12. Remove C-Pillar upper trim and trim cover.

- (1) Carefully pull on trim cover to gain access to the metal clip. Slide a mini screwdriver under metal tab and push upward to disengage clip. Carefully remove trim cover.

- Removal of this trim can be accomplished without removal of the rear seat, however removal is easier with the rear seat removed.
- If you leave the rear seat installed, to ease removal of upper C-Pillar trim bolts, remove rear seatback Headrests LH/RH and lay aside.

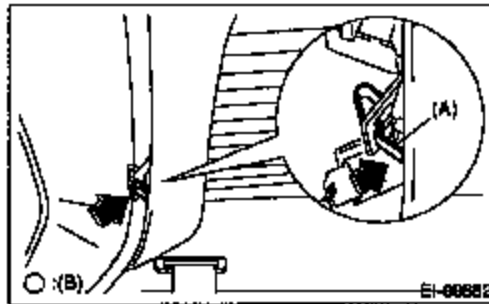

- (2) Carefully remove the cap on the upper portion of the C-Pillar trim. Remove the 4 Bolts to remove the trim.

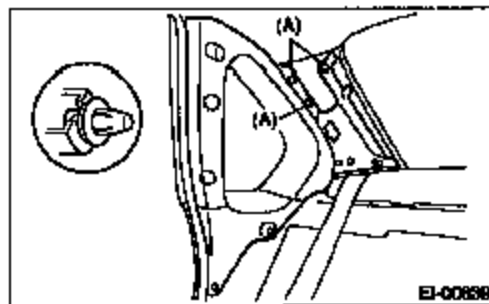

13. Disconnect the antenna lead at the connector located by the driver's side C-Pillar.

14. Reconnect "Negative" Battery cable. (Power Seat equipped vehicles only).

15. Position Front Seats and Seat Back to a position that can provide some support to the Headliner when it is lowered in later steps.

16. Unclip the 3 clips holding the rear of the Headliner near the rear window.

17. Slide Front of Headliner to the passenger side slightly to release the clip in the front of the Headliner. Gently lower the Headliner while releasing any wires from the retaining clips on the Headliner.

continued...

18. Disconnect the "Negative" Battery cable from the Battery Terminal.

IMPORTANT: Make sure battery is disconnected for at least 30 seconds before moving to next step.

19. Disconnect Side Curtain Air Bag electrical connections (located at the rear end of the Side Curtain Air Bag Assembly).

How to disconnect:

- (1) Push the lock arm (A).
- (2) With the lock arm (A) pushed in, move the slide lock (B) in the direction of arrow.
- (3) With the slide lock moved, release the lock arm (back to its original position), and disconnect the connector.

CAUTION: When pulling the side lock or disconnecting the connector, be sure to hold onto the connector and not the wire.

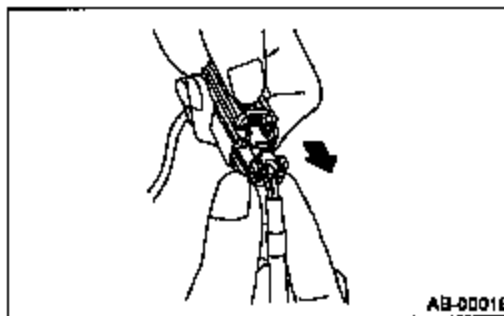
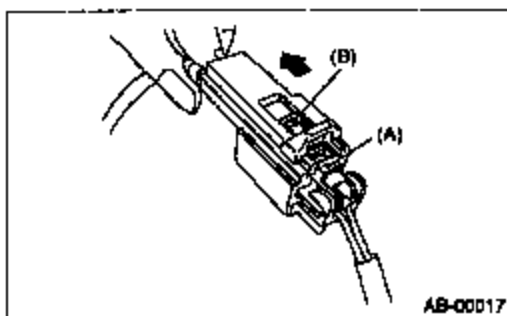

20. Remove both Side Curtain Air Bags – (9 bolts each side – Sunroof Model); (8 bolts each side – Non Sunroof Model). Remove the bolts (A) and clip (B), and then remove the Side Curtain Air Bag module.

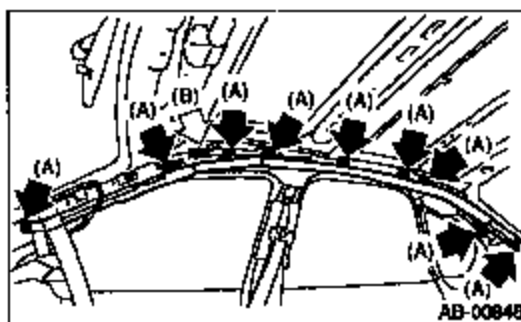

Important:

- Start with the front end of the Side Curtain Air Bag and move towards the rear.
- Be careful not to disturb the routing of the Sun Roof Drain tubes (if equipped).
- Be careful when removing bolts, that the metal brackets which are part of the

continued...

Side Curtain Air Bag Assembly do not damage seat covers or other interior trim parts as they fall to a lower position. You might want to tape or secure a rag to the end brackets for protection.

- **Be careful not to mix the Side Curtain Air Bag bolts with other trim part bolts. Use the same bolts for reinstalling the new Side Curtain Air Bag.**

Side Curtain Air Bag Installation

NOTE: Retain the packaging that the new Side Curtain Air Bag was shipped in. It will be required for returning the removed parts.

21. Install Side Curtain Air Bag.

- Start with the rear bolts and move forward.
- Torque Side Curtain Air Bag Bolts to 5.5 ft.lb.
- Connect Side Curtain Air Bag electrical connectors.

How to connect:

Holding the connector, push it in carefully until a connecting sound is heard.

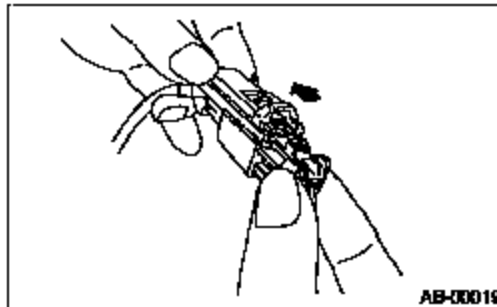

CAUTION: Be sure to insert the connector in until it is locked. Then pull on it gently to make sure that it is locked.

Assembly

Assembly can be accomplished by reversing the order of the disassembly (with the exception of the "Negative" Battery Cable steps, as noted).

22. Vacuum Interior of Vehicle

- Remove gloves before re-entering vehicle to remove all fiberglass residue on Seats, Carpet and Interior Trim, including Instrument Panel.

23. Check operation of interior lighting: Center Room Lamp, Map Lights, and Sun Visor Vanity Lights. Check Sun Roof operation if equipped.

24. Verify Air Bag System operation by turning key on and confirming Air Bag System Warning Lamp goes out after 6 seconds.

25. Reset Radio stations and clock. Verify radio reception.

continued...

RECALL CAMPAIGN IDENTIFICATION LABEL

Type or print the necessary information on a Recall Campaign identification label. The completed label should be attached to the vehicle's upper radiator support.

SUBARU
Campaign Code
WVR-02
COMPLETED
DIST./DEALER NO.
SERIAL NO.
DO NOT REMOVE

CLAIM REIMBURSEMENT AND ENTRY PROCEDURES

Credit for performing this recall campaign will be based on the submission of properly completed repair order information. Dealers may enter the applicable claim information through their Dealer Communications System.

Listed below is claim entry information:

Replace left & right side curtain airbag modules -- Use the following information for claim submission:

Enter labor operation **B820-492** for 1.7 labor hours.

Claim Type	Campaign Code	Labor Operation	Labor Time	Labor Description
Recall/Campaign RC	WVR-02	B820-492	1.7	Replace left & right Side Curtain Air Bag modules

Enter the applicable part number. Parts will be reimbursed at dealer cost plus applicable handling allowance.

MODEL	DESCRIPTION	PART NUMBER
Models with Sunroof	Side Curtain Airbag Module (Right side)	98251AG08A
	Side Curtain Airbag Module (Left side)	98251AG09A
Models without Sunroof	Side Curtain Airbag Module (Right side)	98251AG10A
	Side Curtain Airbag Module (Left side)	98251AG11A

continued...

**Subaru of America, Inc.
Subaru Plaza
P.O. Box 6000
Cherry Hill, NJ 08034-6000
www.subaru.com**

**Important Safety Recall Notice
Subaru Recall Campaign WWR-02
NHTSA Recall No. 04V-274
June 2004**

Dear Subaru Owner:

This notice is sent to you in accordance with the National Traffic and Motor Vehicle Safety Act.

SUBARU OF AMERICA, INC. has decided that a defect, which relates to motor vehicle safety, exists in certain 2005 model year Subaru Legacy Sedan and Outback Sedan vehicles.

DESCRIPTION OF THE SAFETY DEFECT

Subaru has determined that your vehicle has been manufactured with left and right side curtain airbags that may not fully deploy rapidly enough when activated in a side impact collision.

DESCRIPTION OF THE SAFETY HAZARD

The side curtain airbags provide added occupant head protection in the event of certain side impact collisions. The side curtain airbags are mounted in the side trim above the windows between the front pillar and a point over the rear seat. Although the side curtain airbags will deploy in the event of certain side impacts, they may not fully deploy rapidly enough. This may result in failure to provide the intended head protection.

REPAIRS

To correct this condition, Subaru will replace the left and right side curtain airbag modules at no cost to you.

WHAT YOU SHOULD DO

You should immediately contact your Subaru Dealer for an appointment to have this repair performed at no cost to you.

continued...

HOW LONG WILL THE REPAIR TAKE?

The actual time to install the side curtain airbag modules is approximately two hours. However, it may be necessary to leave your vehicle for a longer period of time on the day of your scheduled appointment to allow your dealer flexibility in scheduling. Please present this letter to your Subaru Dealer at the time this repair procedure is performed.

CHANGED YOUR ADDRESS OR SOLD YOUR SUBARU?

If you have moved or sold your vehicle, please complete the enclosed prepaid postcard and mail it to us.

IF YOU NEED FURTHER ASSISTANCE:

To locate the nearest Subaru Dealer you can access our website at www.Subaru.com and select "Find a Dealer". Or, you may call us at 1-800-SUBARU3 (1-800-782-2783) during normal business hours for assistance. Please call us immediately if the dealer fails or is unable to make the necessary repairs free of charge or write to the address listed on the first page of this letter.

You may also contact The Administrator, National Highway Traffic Safety Administration, 400 Seventh Street, S.W., Washington, DC 20590 or call the toll free Auto Safety Hotline at 1-888-327-4236 if you believe the dealer has failed or is unable to remedy your vehicle without charge within a reasonable amount of time.

Your continued satisfaction with your Subaru is important to us. Please understand that we have taken this action in the interest of your safety and your vehicle's proper operation. We sincerely apologize for any inconvenience this matter may cause and urge you to schedule an appointment as soon as possible to have this repair performed.

Sincerely,
Subaru of America, Inc.

Notice to Lessors

Under Federal law the lessor of a vehicle who receives this letter must provide a copy of it to the vehicle lessee(s) within 10 business days from receipt. The lessor must also keep a record of the lessee(s) to whom this letter is sent, the date sent, and the applicable vehicle identification number (VIN). (For the purposes of this section, a lessor means a person or entity that in the last twelve months prior to the date of this notification has been the owner, as referenced on the vehicle's title, of any five or more leased vehicles. A leased vehicle is a vehicle leased to another person for a term of at least four months.)

A subsidiary of Fuji Heavy Industries Ltd.

ATTENTION:
GENERAL MANAGER PARTS MANAGER
CLAIMS PERSONNEL SERVICE MANAGER
IMPORTANT - All Service Personnel Should Read and Initia



SUBARU +

PRODUCT CAMPAIGN BULLETIN

APPLICABILITY: 2005MY Legacy Sedan and
Outback Sedan Vehicles
SUBJECT: Side Curtain Air Bags

NUMBER: WWR-02
DATE: 06/2004

*updated 6-15-04
Includes New 2.0 Labor Time*

INTRODUCTION

Subaru of America, Inc. (SOA) has determined that affected vehicles, listed below, were produced with a Side Curtain Air Bag that may not fully deploy rapidly enough when activated in a side impact collision.

This recall will involve replacement of both Side Curtain Air Bag modules.

AFFECTED VEHICLES

Affected vehicles are identified in the VIN range chart below. **NOTE: Not all vehicles within the VIN range are affected. Coverage for all affected vehicles must be confirmed by using the Vehicle Coverage Inquiry in the Dealer Communication System (DCS).**

2005MY Legacy Sedan / Outback Sedan	4S*BL****5*200001 - 204811
-------------------------------------	----------------------------

*Note 1. Various characters may occupy the VIN positions Identified by "**"*

Note 2. Vehicles identified in the preceding chart may include VINs that were not distributed in the U.S. market. Dealers will be provided a list of VINs that include the owner name and address. This information will enable dealers to follow-up with owners of potentially affected vehicles.

OWNER NOTIFICATION

SOA will contact owners of affected vehicles by telephone when repair parts become available at dealers. A notification letter will also be sent on or around June 14, 2004. A copy of the Owner Notification Letter is included at the end of this bulletin.

continued...



CAUTION: VEHICLE SERVICING PERFORMED BY UNTRAINED PERSONS COULD RESULT IN SERIOUS INJURY TO THOSE PERSONS OR TO OTHERS.

Subaru Service Bulletins are intended for use by professional technicians ONLY. They are written to inform those technicians of conditions that may occur in some vehicles, or to provide information that could assist in the proper servicing of the vehicle. Properly trained technicians have the equipment, tools, safety instructions, and know-how to do the job correctly and safely. If a condition is described, DO NOT assume that this Service Bulletin applies to your vehicle, or that your vehicle will have that condition.

DEALER PROGRAM RESPONSIBILITY

Dealers are to promptly service all vehicles subject to this recall at no charge to the vehicle owner regardless of mileage, age of the vehicle, or ownership.

For affected vehicles sold after the date on the dealer's computer list, dealers are to contact those owners and provide them with a copy of the owner notification letter. They should also arrange to make the required correction according to the instructions in the service procedure section of this bulletin.

VEHICLES IN DEALER INVENTORY

Dealers are also to promptly perform the applicable service procedures defined in this bulletin to correct all affected vehicles in their inventory (new, used, demo). Additionally, whenever a vehicle subject to this recall is taken into dealer new or used inventory, or is in the dealership for service, necessary steps should be taken to ensure the recall correction has been made before selling or releasing the vehicle.

New or used vehicles listed in a recall/campaign that are in dealer stock must be:

- Immediately identified.
- Tagged or otherwise marked to prevent their delivery or use prior to inspection and/or repair.
- Repaired in accordance with the repair procedures outlined in this Product Campaign Bulletin.

Any Authorized Subaru Dealer failing to perform the applicable service procedures defined in this bulletin to correct all affected vehicles in their inventory (new, used, demo) prior to the vehicle being placed in service may be subject to civil penalties of up to \$5,000 per violation (i.e., for each vehicle), as provided in 49 USC §30165(a) of the Safety Act, and will also be in breach of the Subaru Dealer Agreement.

PARTS INFORMATION

Each dealer will automatically be sent a quantity of side curtain airbag modules to repair sold and inventory vehicles.

MODEL	DESCRIPTION	PART NUMBER
Models with Sunroof	Side Curtain Airbag Module (Right side)	98251AG08A
	Side Curtain Airbag Module (Left side)	98251AG09A
Models without Sunroof	Side Curtain Airbag Module (Right side)	98251AG10A
	Side Curtain Airbag Module (Left side)	98251AG11A

continued..

REPAIR PROCEDURES

Tools & Equipment Needed:

1. Clip Tool
2. ¼" Drive 10mm Socket
3. ¼" Drive Ratchet
4. ¼" Drive 6" Extension
5. #2 Phillips Screw Driver
6. Small Mini Screwdriver and/or Plastic Trim Stick
7. Air/Battery Gun or Ratchet
8. Torque Wrench (capable of 5.5 ft.lb spec or 66 in.lb)
9. 10mm Open End Wrench
10. Vacuum Cleaner
11. Protective Covers for Seat, Door Pad, and Instrument Panel
12. Disposable Gloves

NOTE: Before beginning, ensure your clothing and hands are free from dirt and grease. Find a clear and clean area to lay removed trim parts to avoid dirt getting on these parts.

The reverse side of the Headliner Trim Panel has a pressed fiberglass layer. The residue from this layer may cause irritations to the skin and may leave dust inside the interior of the vehicle. Please wear protective gloves to keep fiberglass away from skin and to keep trim clean. Remove gloves after retrofit is complete and thoroughly vacuum the entire interior of the vehicle.

Disassembly

Use extreme care when removing, positioning and storing trim parts to avoid damaging them. Be careful to keep all interior parts clean. Pay close attention to the original position of all trim panels and weather strips to maintain fit & finish.

1. Open hood and all doors. Lower all windows.
2. Record radio stations.
3. Disconnect "Negative" Battery Cable from Battery Terminal.
 - Be careful not to touch Battery Cable to metal objects.
 - Be careful of Battery Terminal grease.
4. Remove the A-Pillar upper trim covers. Start by pushing the metal tab with a flat blade screwdriver or similar tool to release the top portion. Next, gently pull on the trim to disengage the lower clip.

continued...

Note: If the metal clip is damaged during removal, the A-Pillar trim must be replaced.

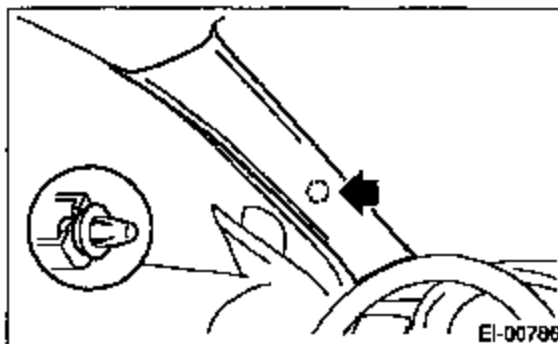
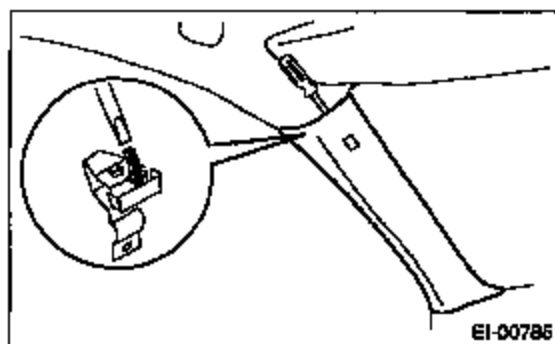

5. Remove the Sun Visors by carefully removing the covers and the mounting screws. If equipped with vanity mirror lights, disconnect the wiring connector. Remove the Sun Visor Hooks by pressing the (A) on both sides, using a flat tip screwdriver and pulling the hook towards you.

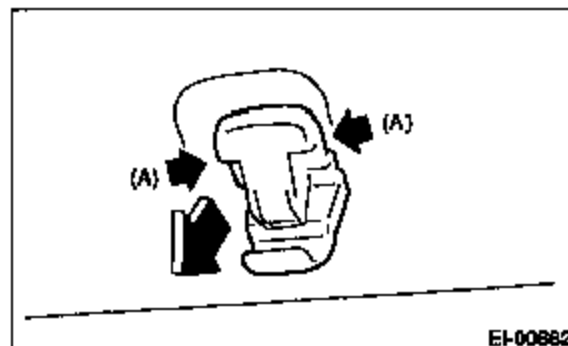
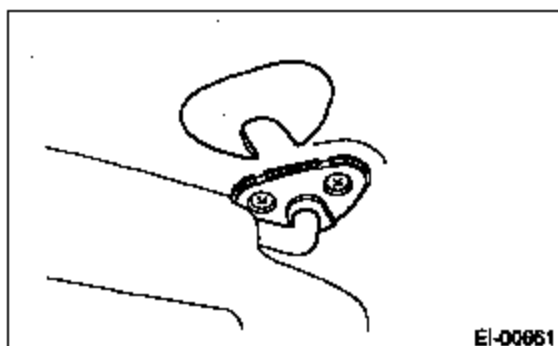

6. Remove the Map Light Lens, Map Light Screws, and disconnect all wiring connectors. If equipped, disconnect wiring connector for Sun Roof.
7. If equipped, remove the Sun Roof Garnish.

continued...

8. Remove front & rear Assist Grips by carefully removing the covers and screws. Pull the left side of assist grip toward you, and rotate the right side of it counterclockwise to remove.

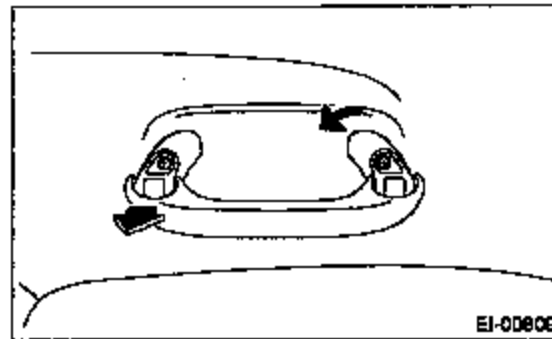

9. Remove B-Pillar lower trim covers (it will stay attached to the Seat Belt) and position it safely out of the way to avoid damaging it or other interior parts.

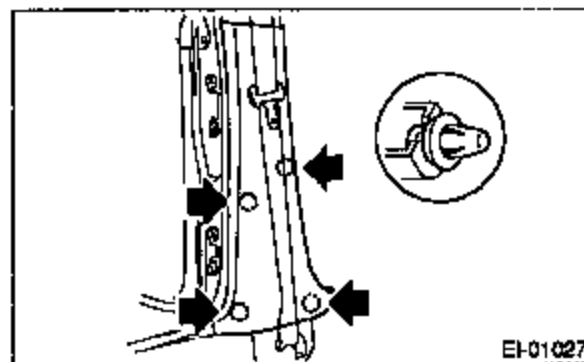

10. Remove B-Pillar upper trim by carefully removing the cap on the upper portion of the pillar trim. Remove the bolt.

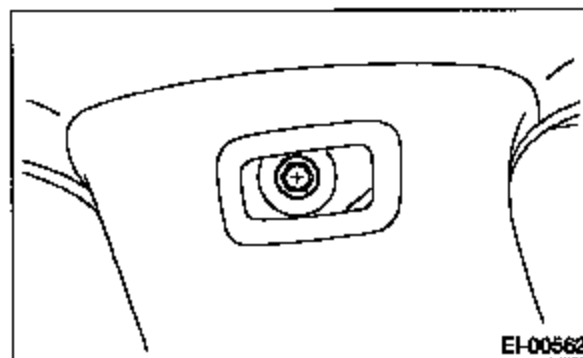

11. Remove center interior Room Light Lens, Room Light, and disconnect wiring connector.

continued...

12. Remove C-Pillar upper trim and trim cover.

(1) Carefully pull on trim cover to gain access to the metal clip. Slide a mini screwdriver under metal tab and push upward to disengage clip. Carefully remove trim cover.

- Removal of this trim can be accomplished without removal of the rear seat, however removal is easier with the rear seat removed.
- If you leave the rear seat installed, to ease removal of upper C-Pillar trim bolts, remove rear seatback Headrests LH/RH and lay aside.

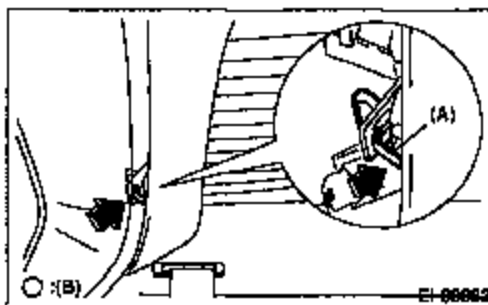

(2) Carefully remove the cap on the upper portion of the C-Pillar trim. Remove the 4 Bolts to remove the trim.

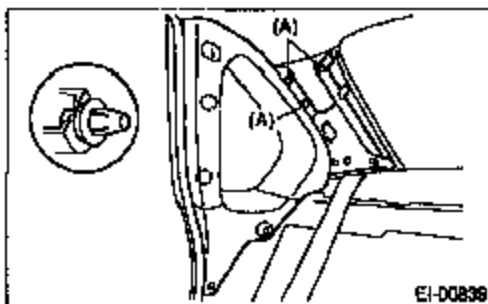

13. Disconnect the antenna lead at the connector located by the driver's side C-Pillar.

14. Reconnect "Negative" Battery cable. (Power Seat equipped vehicles only).

15. Position Front Seats and Seat Back to a position that can provide some support to the Headliner when it is lowered in later steps.

16. Unclip the 3 clips holding the rear of the Headliner near the rear window.

17. Slide Front of Headliner to the passenger side slightly to release the clip in the front of the Headliner. Gently lower the Headliner while releasing any wires from the retaining clips on the Headliner.

continued...

18. Disconnect the "Negative" Battery cable from the Battery Terminal.

IMPORTANT: Make sure battery is disconnected for at least 30 seconds before moving to next step.

19. Disconnect Side Curtain Air Bag electrical connections (located at the rear end of the Side Curtain Air Bag Assembly).

How to disconnect:

- (1) Push the lock arm (A).
- (2) With the lock arm (A) pushed in, move the slide lock (B) in the direction of arrow.
- (3) With the slide lock moved, release the lock arm (back to its original position), and disconnect the connector.

CAUTION: When pulling the side lock or disconnecting the connector, be sure to hold onto the connector and not the wire.

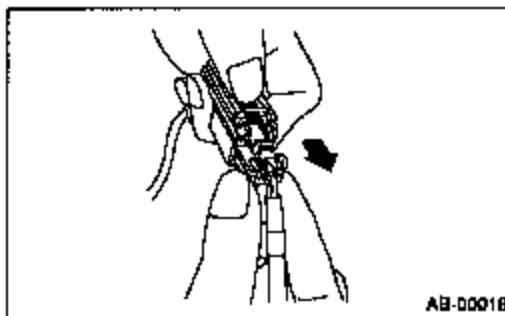
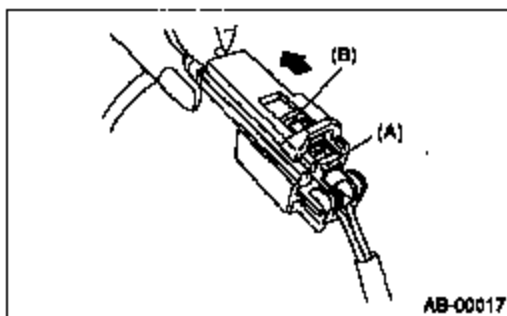

20. Remove both Side Curtain Air Bags – (9 bolts each side – Sunroof Model); (8 bolts each side – Non Sunroof Model). Remove the bolts (A) and clip (B), and then remove the Side Curtain Air Bag module.

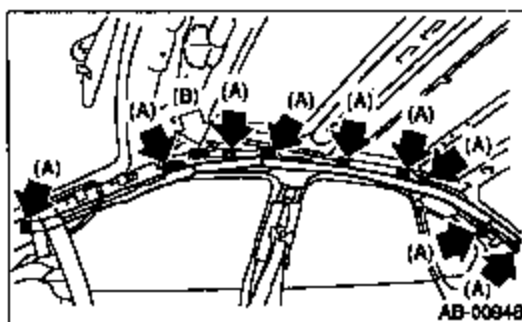

Important:

- Start with the front end of the Side Curtain Air Bag and move towards the rear.
- Be careful not to disturb the routing of the Sun Roof Drain tubes (if equipped).
- Be careful when removing bolts, that the metal brackets which are part of the

continued...

Side Curtain Air Bag Assembly do not damage seat covers or other interior trim parts as they fall to a lower position. You might want to tape or secure a rag to the end brackets for protection.

- Be careful not to mix the Side Curtain Air Bag bolts with other trim part bolts.
- Use the same bolts for reinstalling the new Side Curtain Air Bag.

Side Curtain Air Bag Installation

NOTE: Retain the packaging that the new Side Curtain Air Bag was shipped in. It will be required for returning the removed parts.

21. Install Side Curtain Air Bag.

- Start with the rear bolts and move forward.
- Torque Side Curtain Air Bag Bolts to 5.5 ft.lb.
- Connect Side Curtain Air Bag electrical connectors.

How to connect:

Holding the connector, push it in carefully until a connecting sound is heard.

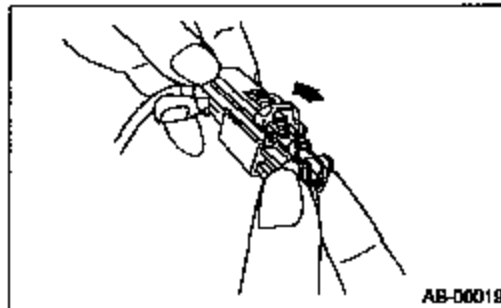

CAUTION: Be sure to insert the connector in until it is locked. Then pull on it gently to make sure that it is locked.

Assembly

Assembly can be accomplished by reversing the order of the disassembly (with the exception of the "Negative" Battery Cable steps, as noted).

22. Vacuum Interior of Vehicle

- Remove gloves before re-entering vehicle to remove all fiberglass residue on Seats, Carpet and Interior Trim, including Instrument Panel.

23. Check operation of interior lighting: Center Room Lamp, Map Lights, and Sun Visor Vanity Lights. Check Sun Roof operation if equipped.

24. Verify Air Bag System operation by turning key on and confirming Air Bag System Warning Lamp goes out after 6 seconds.

25. Reset Radio stations and clock. Verify radio reception.

continued...

RECALL CAMPAIGN IDENTIFICATION LABEL

Type or print the necessary information on a Recall Campaign identification label. The completed label should be attached to the vehicle's upper radiator support.

SUBARU
Campaign Code WVR-02
COMPLETED DIST./DEALER NO.
SERIAL NO.
DO NOT REMOVE

CLAIM REIMBURSEMENT AND ENTRY PROCEDURES

Credit for performing this recall campaign will be based on the submission of properly completed repair order information. Dealers may enter the applicable claim information through their Dealer Communications System.

Listed below is claim entry information:

Replace left & right side curtain airbag modules – Use the following information for claim submission:

Enter labor operation B820-492 for 2.0 labor hours.

Claim Type	Campaign Code	Labor Operation	Labor Time	Labor Description
Recall/Campaign RC	WVR-02	B820-492	2.0	Replace left & right Side Curtain Air Bag modules

Enter the applicable part number. Parts will be reimbursed at dealer cost plus applicable handling allowance.

MODEL	DESCRIPTION	PART NUMBER
Models with Sunroof	Side Curtain Airbag Module (Right side)	98251AG08A
	Side Curtain Airbag Module (Left side)	98251AG09A
Models without Sunroof	Side Curtain Airbag Module (Right side)	98251AG10A
	Side Curtain Airbag Module (Left side)	98251AG11A

continued...

**Subaru of America, Inc.
Subaru Plaza
P.O. Box 6000
Cherry Hill, NJ 08034-6000
www.subaru.com**

**Important Safety Recall Notice
Subaru Recall Campaign WWR-02
NHTSA Recall No. 04V-274
June 2004**

Dear Subaru Owner:

This notice is sent to you in accordance with the National Traffic and Motor Vehicle Safety Act.

SUBARU OF AMERICA, INC. has decided that a defect, which relates to motor vehicle safety, exists in certain 2005 model year Subaru Legacy Sedan and Outback Sedan vehicles.

DESCRIPTION OF THE SAFETY DEFECT

Subaru has determined that your vehicle has been manufactured with left and right side curtain airbags that may not fully deploy rapidly enough when activated in a side impact collision.

DESCRIPTION OF THE SAFETY HAZARD

The side curtain airbags provide added occupant head protection in the event of certain side impact collisions. The side curtain airbags are mounted in the side trim above the windows between the front pillar and a point over the rear seat. Although the side curtain airbags will deploy in the event of certain side impacts, they may not fully deploy rapidly enough. This may result in failure to provide the intended head protection.

REPAIRS

To correct this condition, Subaru will replace the left and right side curtain airbag modules at no cost to you.

WHAT YOU SHOULD DO

You should immediately contact your Subaru Dealer for an appointment to have this repair performed at no cost to you.

continued...

HOW LONG WILL THE REPAIR TAKE?

The actual time to install the side curtain airbag modules is approximately two hours. However, it may be necessary to leave your vehicle for a longer period of time on the day of your scheduled appointment to allow your dealer flexibility in scheduling. Please present this letter to your Subaru Dealer at the time this repair procedure is performed.

CHANGED YOUR ADDRESS OR SOLD YOUR SUBARU?

If you have moved or sold your vehicle, please complete the enclosed prepaid postcard and mail it to us.

IF YOU NEED FURTHER ASSISTANCE:

To locate the nearest Subaru Dealer you can access our website at www.Subaru.com and select "Find a Dealer". Or, you may call us at 1-800-SUBARU3 (1-800-782-2783) during normal business hours for assistance. Please call us immediately if the dealer fails or is unable to make the necessary repairs free of charge or write to the address listed on the first page of this letter.

You may also contact The Administrator, National Highway Traffic Safety Administration, 400 Seventh Street, S.W., Washington, DC 20590 or call the toll free Auto Safety Hotline at 1-888-327-4236 if you believe the dealer has failed or is unable to remedy your vehicle without charge within a reasonable amount of time.

Your continued satisfaction with your Subaru is important to us. Please understand that we have taken this action in the interest of your safety and your vehicle's proper operation. We sincerely apologize for any inconvenience this matter may cause and urge you to schedule an appointment as soon as possible to have this repair performed.

Sincerely,
Subaru of America, Inc.

Notice to Lessee

Under Federal law the lessor of a vehicle who receives this letter must provide a copy of it to the vehicle lessee(s) within 10 business days from receipt. The lessor must also keep a record of the lessee(s) to whom this letter is sent, the date sent, and the applicable vehicle identification number (VIN). (For the purposes of this section, a lessor means a person or entity that in the last twelve months prior to the date of this notification has been the owner, as referenced on the vehicle's title, of any five or more leased vehicles. A leased vehicle is a vehicle leased to another person for a term of at least four months.)

A subsidiary of Fuji Heavy Industries Ltd.

Part Number Application for WWR-02 Side Curtain Airbag Recall

TO: All Subaru Dealers
FROM: Lou Ann Brickey-Vega
DEPARTMENT: Fixed Operations
DATE: 6/8/2004 15:25:16 EST

The Part Number application for the WWR-02 Side Curtain Airbag Recall is as follows:

98251AG08A = S + SOBK+S.25ILTD+S.25GTLTD
98251AG09A = S + SOBK+S.25ILTD+S.25GTLTD

98251AG10A = S.25I + S.25GT
98251AG11A = S.25I + S.25GT

Also, the model codes for non-sunroof cars are: 5AA, 5AB, 5AE, 5AF;
and the model codes for sun roof cars are: 5AC, 5AD, 5AG, 5AH, 5AI, 5AJ, 5CA



subaru

Subaru of America

Daily 275

MTD 5522

YTD 74171

Home

Home

- Added Security
- Customer Benefits
- Dealer Training
- ▶ Financing
- ▶ Fixed Operations
- Incentives
- Links
- Marketing
- Marketplace
- News
- Reports/Messages
- Retail Environment
- ▶ Service
- Subaru Difference
- Vehicles

Returning of Old Parts for WWR-02 Side Curtain Airbag Recall

TO: All Subaru Dealers
FROM: Lou Ann Brickey-Vega
DEPARTMENT: Fixed Operations
DATE: 6/9/2004 16:13:2 EST

We are currently working on a procedure for the return of the removed parts.

The preliminary plan is to send each dealer new cartons, a return procedure and a pre-printed bill of lading to return these parts. Since the plans are not finalized, we ask that all dealers hold on to the original packaging in the event that the decision is made to not send out replacement cartons.

As soon as plans are finalized there will be another announcement posted to subarunet.com.

We appreciate your patience in this matter.

[back](#)

subarunet.com

Subaru of America

Daily 483

MTD 10463

YTD 79112

Home

Home

New Products

New Arrivals

Specials

Added Security

Customer ID - SWIS

Dealer Training

Financials

Fixed Operations

Incentives

Links

Marketing

Marketplace

News

Reports/Messages

Retail Environment

Service

Subaru Difference

Vehicles

Claim Submission for WWR-02 Side Curtain Air Bag

TO: All Subaru Dealers
FROM: Linda Scott
DEPARTMENT: Service
DATE: 6/17/2004 16:6:42 EST

By this time, all dealers should have the parts and information needed to perform the WWR-02 Side Curtain Airbag Recall that was recently released. We strongly encourage all dealers to schedule these vehicles for the air bag replacement as soon as possible. Once the repair is completed, please submit your claim for reimbursement immediately. We appreciate your cooperation in this matter.

[back](#)

Return Procedure of Old Parts for WWR-02 Side Curtain Airbag Recall

TO: All Subaru Dealers
FROM: Dan Ohms
DEPARTMENT: SOA Traffic
DATE: 6/21/2004 14:36:1 EST

Takata has finalized the procedure for the return of the removed parts. They will be shipping each dealer new cartons, a return procedure and a pre-printed bill of lading to return these parts. Please [click here](#) to view and print a copy of the procedures.

[back](#)

Head Side Airbag Box Closing Instructions (2 Airbags per Box)

- STEP 1:** Inspect the corrugated box to ensure it is in good physical condition
No cuts, No tears, foam still present in interior of box
- STEP 2:** Place the 2 airbags and 2 completed data forms (page 4 of this packet) inside box and close, as shown in Pic. "A" & "B"

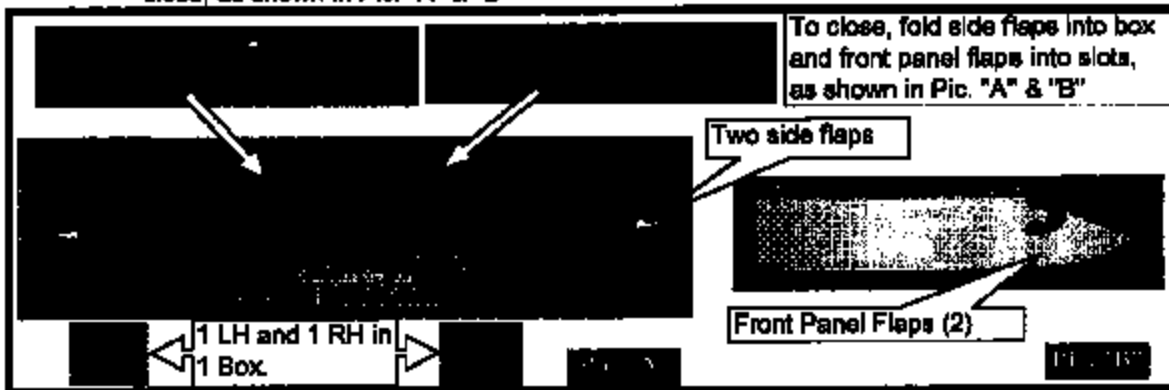

- STEP 3:** Place 1 (one) Hazmat Class 9 Label (1 Included in Kit) covering diamond shape on top of box. (see Pic. "C")

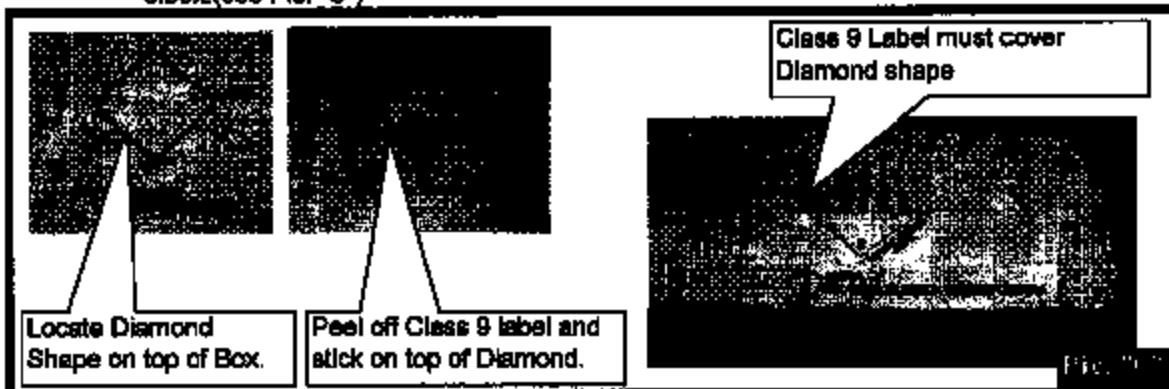

- STEP 4:** The box must be sealed with 3 (three) Round Tamper Proof Label (3 included in Kit), follow instructions below. (see Pic. "D") "to make placement easy put box on its side"

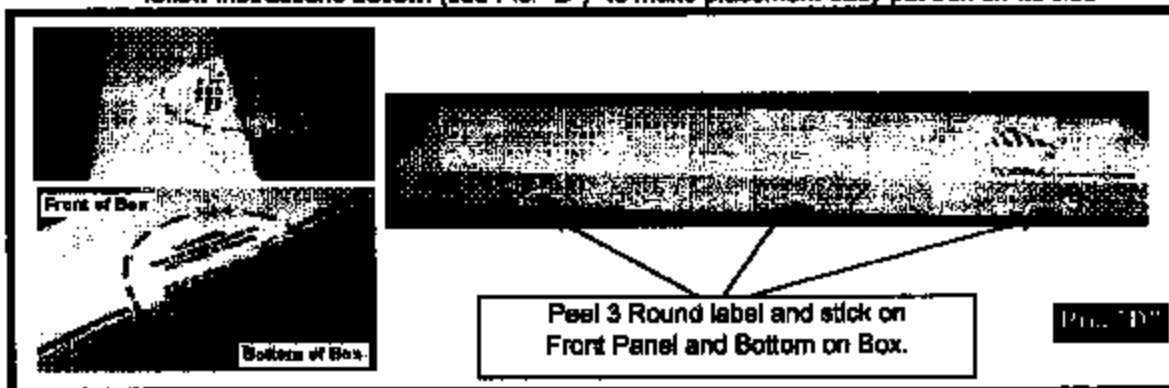

Head Side Airbag Box Return Kit

NOTE 1: The return Kit includes the following:
1 box, 1 FedEx USA Airbill, 1 Shipper's Declaration for Dangerous Goods (3 copies), 1 Clear Mailing Envelope, 3 Tamper proof Round Tapes, 1 Class 9 label
1 Classification of Explosives Document (3 copies), 1 Set of Closing Instructions.

1 Service Box.

You will find all required documents inside the box

1 FedEx USA Airbill "Form"

This document will be partially filled out, only fill out "Section 1 FROM"

Only print on Shaded area

Shipper's Declaration for Dangerous Goods

fill out "Shipper" information in top left

fill out " Name and Title of Signatory", "Place and Date" and "Signature", on lower right.

Affix FedEx Airbill to TOP of Box
Affix "Declaration and Classification of Explosives" to TOP of box using clear envelope.

Do not Cover this Area

**PLEASE FILL IN THE ATTACHED FORM
AND RETURN WITH REPLACED MODULES.**

**PLEASE FILL IN THIS FORM PRIOR TO
REPLACEMENT MODULE INSTALLATION:**

1.- DEALER NAME: _____

2.- DEALER
ADDRESS: _____

3.- CAR WAS PURCHASED? (YES/NO): _____

4.- CAR IS OFF THE DEALER LOT? YES/NO): _____

5.- VEHICLE MILAGE: _____

6.- DATE OF MODULE REPLACEMENT TO THE CAR: _____

7.- VIN NUMBER OF VEHICLE: _____

8.COMMENTS: _____

subarunet.com

Subaru of America

Daily 867

MTD 10847

YTD 79496

Home

Home

Subaru of America

Subaru of America

- Add-on Security
- Customer Di. Serv.
- Dealer Training
- Financials
- Field Operations
- Incentives
- Lease
- Marketing
- Marketplace
- News
- Reports/Bulletins
- Retail Environment
- Service
- Subaru Difference
- Vehicles

Updated WWR-02 Labor Times

TO: All Subaru Dealers
FROM: Subaru of America, Inc.
DEPARTMENT: Service
DATE: 6/28/2004 13:5:43 EST

Effective immediately, the labor time for performing the WWR-02 campaign has been changed from 1.7 to 2.0 hours. Therefore, all future claims submitted for reimbursement using labor operation number B820-492 should be entered using 2.0 labor hours. Additionally, all previously submitted claims will be adjusted by SOA to reflect the updated labor time.

The campaign bulletin found on STIS has been corrected to reflect this change.

[back](#)