

DAIMLERCHRYSLER

DaimlerChrysler Corporation
Stephan J. Speth
Director
Vehicle Compliance & Safety Affairs

June 28, 2004

Mr. Kenneth N. Weinstein
Associate Administrator, Safety Assurance
National Highway Traffic Safety Administration
400 Seventh Street, S.W.
Washington, D.C. 20590

Dear Mr. Weinstein:

Reference: NHTSA Identification Number 04V-021

Enclosed are representative copies of additional dealer communications updating information relating only to the 1993 through 1997 model year "LH" vehicles involved in the referenced recall.

This completes DaimlerChrysler's package of information for this recall as required by the Defects Report Regulation.

Sincerely,



Stephan J. Speth, Director
Vehicle Compliance and Safety Affairs

Enclosure: Update – Safety Recall C45
Revised Dealer Service Instructions – Safety Recall C45

cc: K. C. DeMeter

*To:dlrall\$1,dlrall\$3,dlrall\$4

ATTENTION: Service and Parts Managers

UPDATE -- Safety Recall C45 - Floor Shifter Ignition/Park Interlock

Involved Vehicles: 1993-1997 (LH) Chrysler Concorde, LHS and
300M; Dodge Intrepid and Eagle Vision

DEALER PARTS INFORMATION:

The Parts Section of the Dealer Service Instructions incorrectly specifies one of the LH Load Limiting Push Rod part number applications. The correct Load Limiting Push Rod part number information for all LH models is listed below.

. 1993 through 1997 LH vehicles EQUIPPED WITH A COBRA SHIFTER HANDLE require the long load limiting push rod, P/N CBWSC451 (NOT CBWSC452 as shown on Page 3).

. 1993 through 1997 LH vehicles EQUIPPED WITH A T-HANDLE SHIFTER require the short load limiting push rod, P/N CBXTC453 (as shown on Page 3).

. 1998 and 1999 LH vehicles EQUIPPED WITH A COBRA SHIFTER HANDLE require load limiting push rod with the ball end, P/N CBWSC452 (as shown on Page 3).

DEALER SERVICE INSTRUCTIONS:

In order to assure that the proper Load Limiting Push Rod is being used, an additional step has been added to the dealer service instructions to verify that the original push rod and the new load limiting push rod are the same length.

REVISED SAFETY RECALL C45 DEALER SERVICE INSTRUCTIONS ON TechCONNECT:

A revised version of Recall C45 will be located on the opening page of TechCONNECT with the corrected parts information on June 28, 2004.

Please print the revised version of Recall C45 for your files and discard all previous copies.

The revised version of Recall C45 will also be added to the normal TechCONNECT location in the near future.

If you have any questions regarding this update, please contact your Service and Parts District Manager.

Customer Services Field Operations
DaimlerChrysler Corporation

DAIMLERCHRYSLER

Revised: June 2004

Dealer Service Instructions for:

Safety Recall C45 **Floor Shifter Ignition/Park Interlock**

This revision corrects the Load Limiting Push Rod part number application for 1993 – 1997 LH vehicles equipped with a Cobra shifter handle.

IMPORTANT: Effective immediately, this recall (C45) cancels and supersedes Safety Recall No. 789 – Floor Shifter and Ignition/Park Interlock Cable. All vehicles involved in Recall 789, whether completed or not, must have Recall C45 performed.

Models

- | | |
|----------------|--|
| 1993-1999 (LH) | Chrysler Concorde, LHS and 300M; Dodge Intrepid and Eagle Vision |
| 1995-1999 (JA) | Chrysler Cirrus, Dodge Stratus and Plymouth Breeze |
| 1996-1999 (JX) | Chrysler Sebring Convertible |

NOTE: This recall applies only to the above vehicles equipped with an automatic transaxle and a floor mounted shifter.

IMPORTANT: Some of the involved vehicles may be in dealer used vehicle inventory. **Dealers should complete this recall service on these vehicles before retail delivery.** Dealers should also perform this recall on vehicles in for service. Involved vehicles can be determined by using the VIP inquiry process.

Subject

The transaxle floor shifter ignition/park interlock system on about 2,300,000 of the above vehicles may become inoperative. This may allow the shifter to be moved out of the "Park" position with the ignition key removed (or in the "Lock" position). It may also allow the ignition key to be removed when the shifter has not been placed in the "Park" position. If the shifter is not in the "Park" position, these conditions could allow the vehicle to roll away and cause a crash without prior warning.

Repair

The shift interlock system must be inspected for proper operation. Vehicles with a functional interlock system will have a load limiting shift lever push rod installed into the original shifter assembly. Vehicles with an inoperative interlock system must have the floor shifter assembly replaced.

IMPORTANT: This recall will be implemented in six (6) phases (refer to page 13 for details). Parts will not be available before the applicable phase begins.

Alternate Transportation

If inspection determines that shifter assembly replacement is required and the vehicle must be held overnight, dealers should attempt to minimize customer inconvenience by placing the owner in a loaner vehicle.

Parts Information

IMPORTANT: This recall will be implemented in six (6) phases. Involved dealers will receive enough phase one (1) Load Limiting Push Rod Packages to service 10% of applicable vehicles. Additional Push Rod packages and shifters for implemented phases may be ordered as needed to support customer demand.

The appropriate load limiting push rod part number for each vehicle is displayed on the DealerCONNECT VIP function.

MOST OF THE VEHICLES INVOLVED IN THIS RECALL WILL ONLY REQUIRE A LOAD LIMITING PUSH ROD.

Involved dealers will receive an initial quantity of remaining load limiting push rod packages before owner notification for those phases begin. **PARTS WILL NOT BE AVAILABLE BEFORE THE APPLICABLE PHASE BEGINS.**

A. Load Limiting Push Rod Packages

1,2,3	1996 - 1999 1993 - 1997	JA/JX LH	Cobra Handle	CBWSC451	Load Limiting Push Rod (Long Rod)	1
4,5	1998 - 1999	LH	Cobra Handle	CBWSC452	Load Limiting Push Rod (Short Rod)	2
6	1995 - 1997 1993 - 1997	JA LH	T-Handle	CBXTC453	Load Limiting Push Rod (Ball End)	3

Each package contains one load limiting push rod and return spring assembly.

Parts Information (Continued)

B. Floor Shifter Assemblies

Phase	Model Year	Body Code	Transmission	Sales Code	Shifter Handle Type (Reference)	Floor Shifter Assembly Part Number
1	1996-1997	JX	Standard Automatic / DG-		Cobra Handle	CBKTC456
2	1996-1999	JX	AutoStick / DHD		Cobra Handle	CBNTC455
	1996-1999	JA	AutoStick / DHD		Cobra Handle	
	1993-1997	LH	AutoStick / DHD		Cobra Handle	
3	1998-1999	JX	Standard Automatic / DG-		Cobra Handle	CBFSC459
	1998-1999	JA	Standard Automatic / DG-		Cobra Handle	
4	1998-1999	LH	AutoStick / DHD		Cobra Handle	CBNSC458
5	1998-1999	LH	Standard Automatic / DG-		Cobra Handle	CBSSC457
6	1995-1997	JA	Standard Automatic / DG-		T-Handle	CBMTC454
	1993-1997	LH	Standard Automatic / DG-		T-Handle	

NOTE: Due to the small number of involved vehicles expected to require shifter assembly replacement, no shifter assemblies will be distributed initially.

Shifter assemblies should be ordered only after inspection determines that replacement is required. *Very few vehicles are expected to require shifter assembly replacement.*

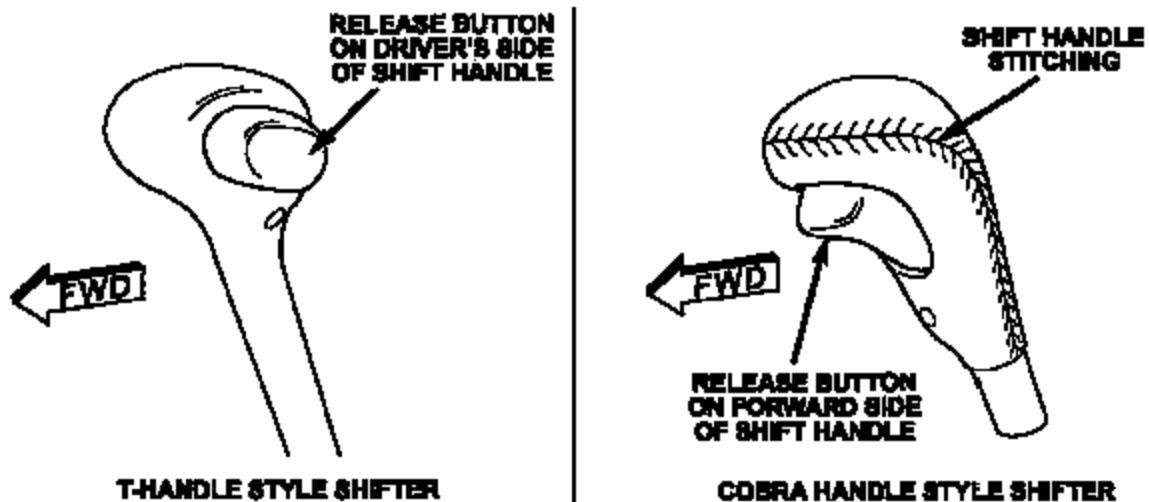

Figure 1

Service Procedure**A. Inspect Ignition/Park Shift Interlock Operation:**

With the ignition key removed and your foot on the brake, depress the shifter button and attempt to move the shift lever out of the “Park” position.

IMPORTANT: Use normal effort when attempting to move the shift lever. Use of excessive force may cause the floor shifter assembly to break.

- If the shift lever **CANNOT** be moved out of the “Park” position, continue with Section “B” – Install Load Limiting Push Rod.
- If the shift lever **CAN** be moved out of the “Park” position, the shifter assembly must be replaced. Continue with Section “C” – Floor Shifter Replacement.

B. Install Load Limiting Push Rod

NOTE: Only those vehicles with a properly functioning ignition/park interlock, as determined by the inspection in Section “A” require the load limiting push rod.

1. Secure the vehicle to prevent it from rolling during this service procedure.
2. Insert the key into the ignition and turn it to the “RUN” position.
3. Place shift lever into the full rearward position.
4. Using an allen wrench, loosen the shift handle set screw (Figure 2).
5. Remove the shift handle from the shift lever.
6. Attempt to remove the plastic push rod from the shift lever by gently pulling upward on the push rod by hand:
 - If the push rod **can be removed**, remove the push rod and continue with Step 12 of this procedure.
 - If the push rod **cannot be removed**, continue with Step 7 of this procedure.

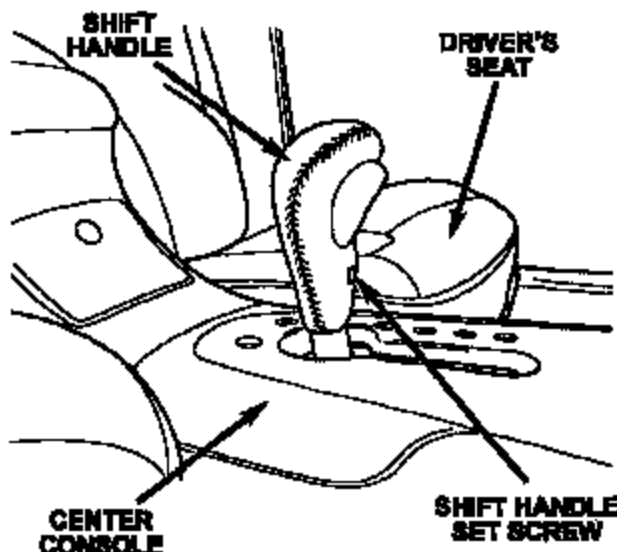

Figure 2 – LH with Cobra Handle & AutoStick Shown

Service Procedure (Continued)

7. Using a trim stick, remove the center console shift bezel and boot.

NOTE: Some vehicles may require the removal of the radio bezel to gain access to the shift bezel and boot.

8. Locate the shift lever push rod retaining dimple (Figure 3). Most vehicles will have the dimple on the front side of the shift lever.

NOTE: Some vehicles will have the dimple on the back side of the shift lever.

9. Drill out the dimple using a 1/4" (6.5 mm) diameter drill bit (Figure 3).

CAUTION: Care must be taken not to drill through or into the plastic push rod.

NOTE: Place a shop towel around the shift lever to catch any metal chips created while drilling out the shift lever dimple.

10. Clamp locking pliers onto the end of the push rod. (Figure 4).
11. Use the following procedure to cut a groove into the plastic push rod which will create a channel that will release the push rod from the shifter.
- Insert the drill bit into the hole made in Step 9 until it lightly rests against the plastic push rod (Figure 4).
 - While operating the drill, gently pull up on the locking pliers (Figure 4) that were installed in Step 10.

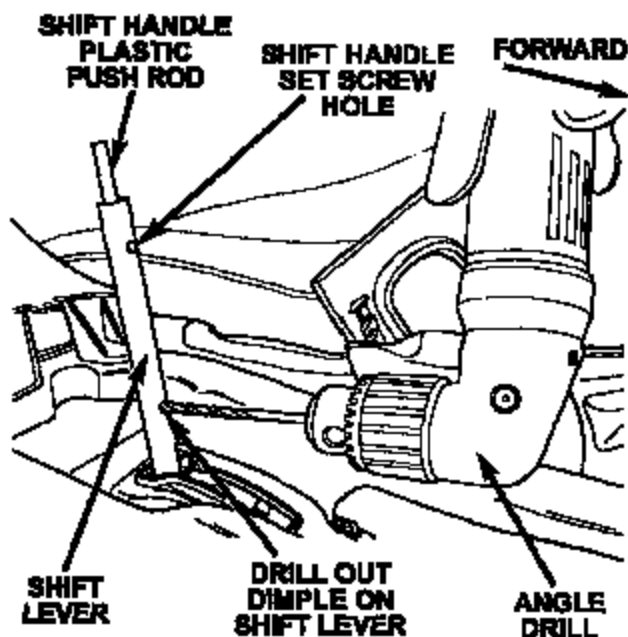

Figure 3 – LH Model Shown

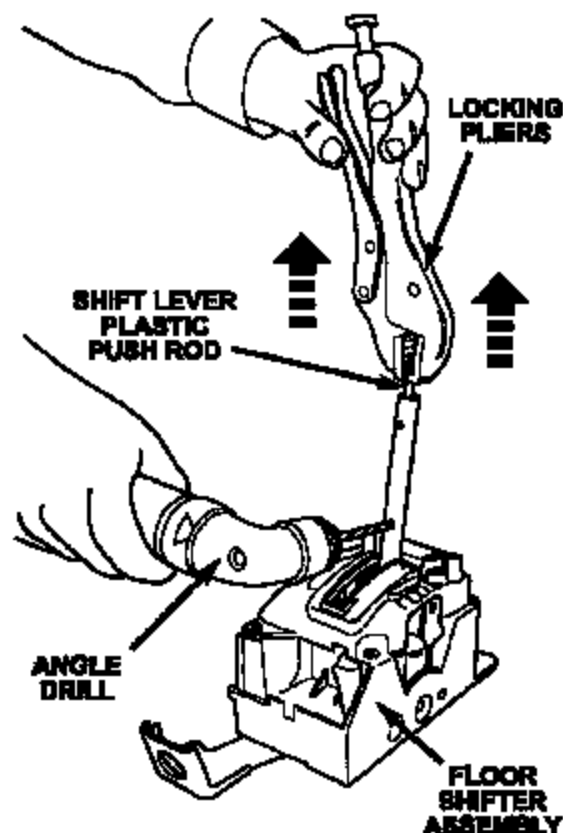

Figure 4 – LH Model Shown

Service Procedure (Continued)

12. If the push rod preload spring does not come out with the push rod, use the original push rod as a tool to remove the preload spring from shift lever.

CAUTION: The original push rod preload spring must be removed from the shift handle before continuing with this procedure.

13. Verify that the new load limiting push rod and the original push rod are the same length.
14. Discard the old push rod and preload spring.
15. For vehicles that had the dimple drilled out, use a small round file to remove any remaining metal burrs from the inside of the shift lever at the hole drilled in Step 9 (Figure 5).

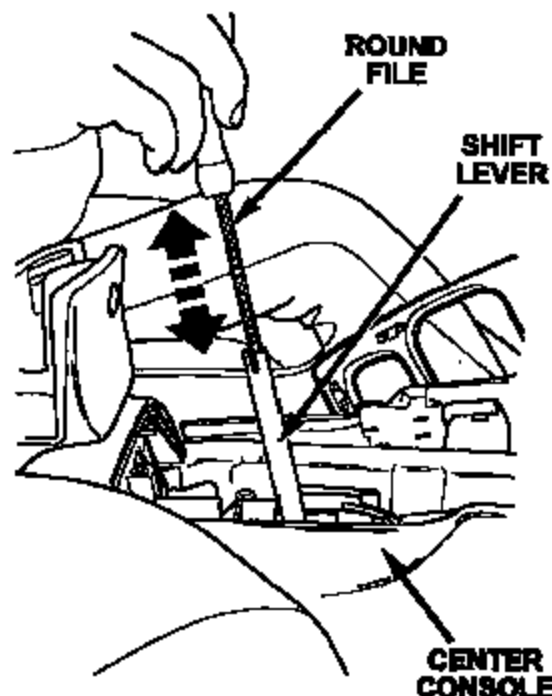

Figure 5

CAUTION: Failure to remove all metal burrs from inside the shift lever may make installation of the new push rod extremely difficult.

16. Orient the new load limiting push rod so that the forks are parallel with the center console (Figure 6). Insert the load limiting push rod, with the preload spring in position, into the shift lever. Be sure that the push rod is fully seated.
17. Install the shift bezel and boot.
18. If required, install the radio bezel.
19. Install the shift handle and tighten the set screw.
20. Check for proper shifter and ignition/park interlock operation.

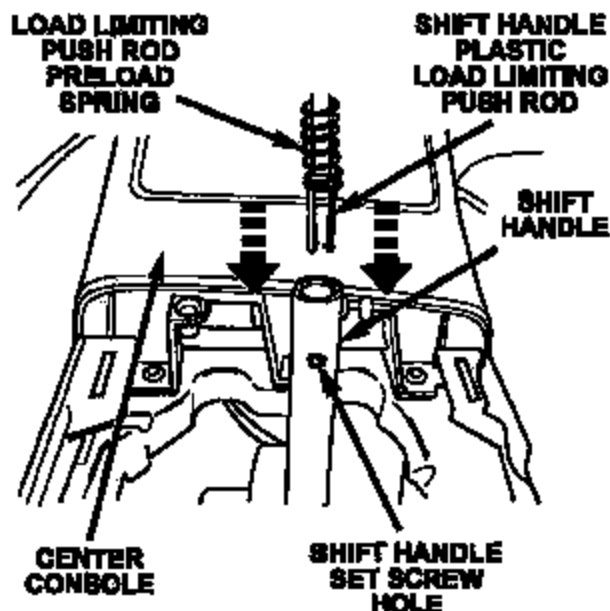

Figure 6 – LH Model with Cobra Handle Shown

Service Procedure (Continued)**C. Floor Shifter Replacement**

NOTE: Only those vehicles with an inoperative ignition/park interlock, as determined by the inspection in Section "A," require shifter replacement. New shifter assemblies already contain the load limiting push rod.

1. Disconnect the negative battery cable.
2. Secure the vehicle to prevent it from rolling during this service procedure.
3. Insert the key into the ignition and turn to "RUN" position.
4. Place shift lever into the full rearward position.
5. Using an allen wrench, loosen the set screw in shift handle (Figure 2).
6. Remove the shift handle from the shift lever.
7. Remove the shift bezel and/or boot (Figure 7).

NOTE: Some models may require the removal of the radio bezel to gain access to the shift bezel and boot.

8. With the shifter in the "PARK" position, disconnect the gearshift cable from the cable attaching stud (pin).
9. If the gearshift cable anchor bracket is part of the shifter, remove the gearshift cable retaining clip from the shifter base slot and remove the cable (Figure 7).
10. With the shifter in the "PARK" position, remove the interlock cable from the shifter.

NOTE: Use care not to kink the cable or break the tab on the interlock cable conduit end fitting.

11. Remove the shifter-to-floor pan attaching nuts (Figure 7).

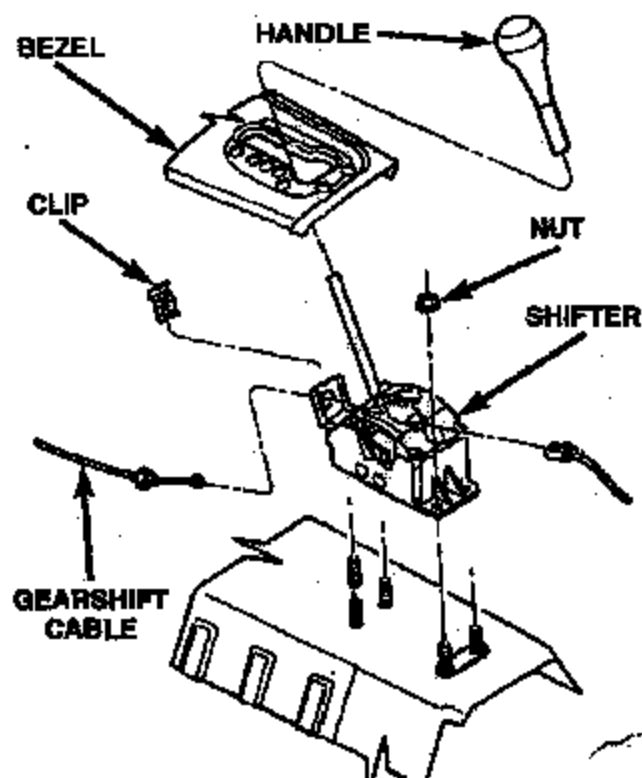

Figure 7 - Typical

Service Procedure (Continued)

12. Remove the old shifter assembly from the vehicle. Discard the old shifter.
13. Install the new shifter assembly into position.

CAUTION: Make sure the eyelet of the shifter cable is inside of the shifter housing.

14. Install the shifter-to-floor pan attaching nuts. Tighten the nuts to 150 in. lbs. (17 N·m).
15. Install the interlock cable to the shifter housing and connect the cable to the actuator arm.
16. Connect the shift cable to the shifter.
17. Adjust the shift cable using the following procedure:

- a. Loosen the gearshift cable adjuster nut at the shifter assembly (Figure 8).
- b. Move the gearshift lever located on the transaxle to the “Park” position.

CAUTION: The transaxle park sprag must be engaged when adjusting the shift cable. Rock the vehicle to verify that the sprag is engaged.

- c. Place the shift lever in the “Park” position.
- d. Verify that the shift lever and transaxle are both in the “Park” position.
- e. Tighten the adjuster nut to 225 in. lbs. (25 N·m) (Figure 8).
- f. Check adjustment as follows:
 - Detent position for neutral and drive should be within limits of the shift lever gate stops.
 - Key start must occur only when the shift lever is in the park or neutral positions.

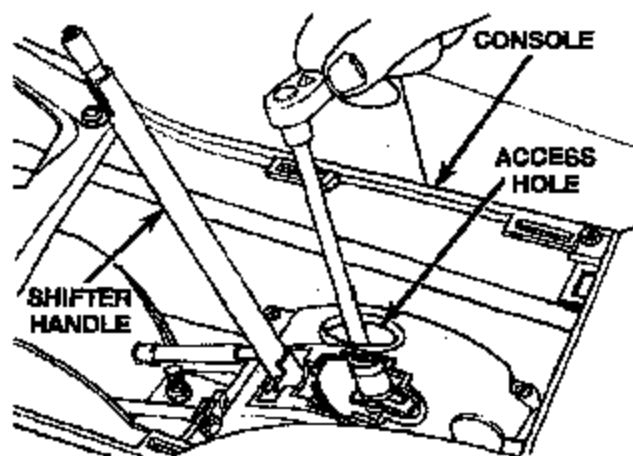

Figure 8

Service Procedure (Continued)

18. Adjust the ignition/park interlock cable using the following procedure:

- a. Place the shift lever in the “Park” position.
- b. Remove the ignition key from the column lock.

c. **Vehicles with a self adjust cable:**

1. Spread the lock clip legs while pulling the lock clip upward to unlock the self-adjuster lock (Figure 9).
2. Once the lock clip is lifted, the cable will automatically adjust.
3. Push the lock clip down to lock the cable into place.

d. **Vehicles with a manual adjust cable:**

1. Loosen the adjustment nut located on the shifter housing (Figure 10).
2. Allow the cable to adjust itself to the correct position.
3. Tighten the adjustment nut to 53 in. lbs (6 N·m).

e. Verify the interlock cable adjustment:

- With the ignition key in the “LOCK” position, the shift lever should be locked in the “PARK” position.
- Place the ignition switch in the “RUN” position. Move the shift lever to the reverse position. You should not be able to remove the ignition key from the lock cylinder.
- Place the shift lever in the “PARK” position. Turn the ignition key to the “LOCK” position. You should be able to remove the ignition key from the lock cylinder.

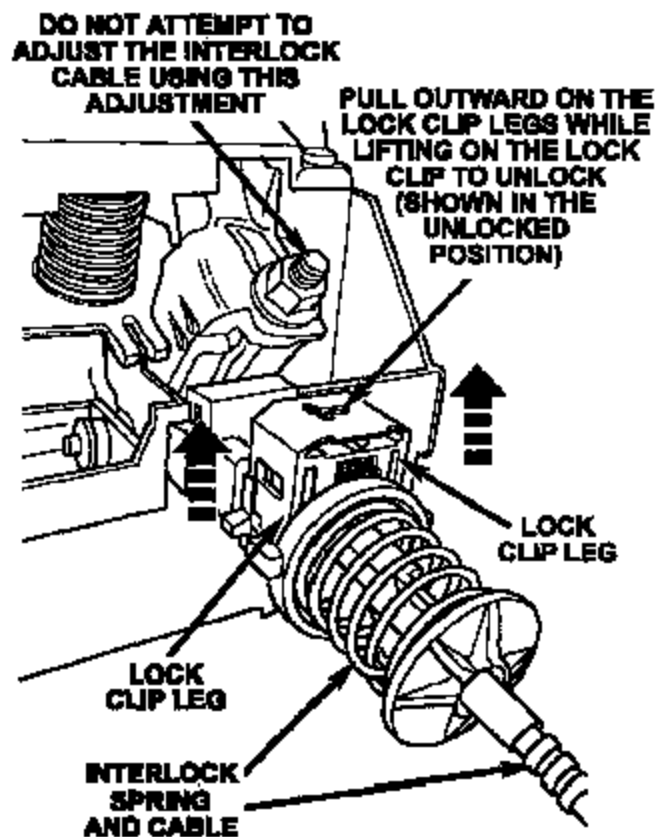

Figure 9 – Self Adjusting Cable

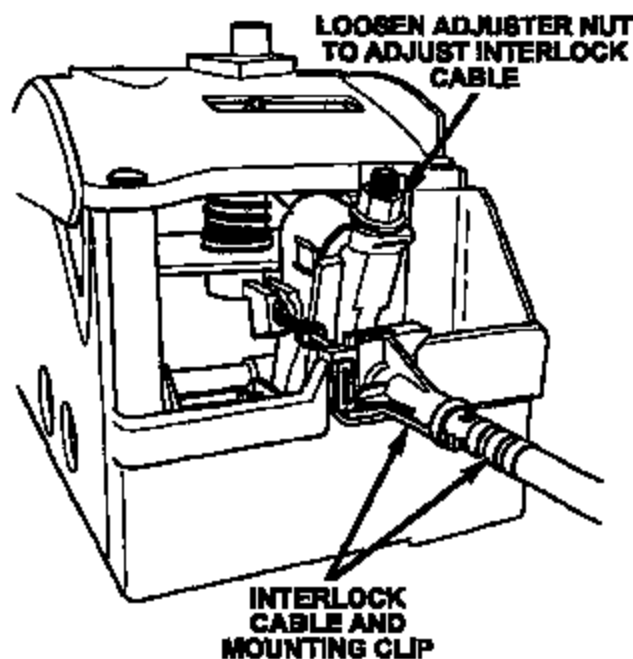

Figure 10 – Manual Adjusted Cable

Service Procedure (Continued)

19. Install the shift bezel and boot.
20. If required, install the radio bezel.
21. Install the shift handle and tighten the set screw.
22. Connect the negative battery cable.
23. Check for proper shifter and ignition/park interlock operation.

Completion Reporting and Reimbursement

Claims for vehicles that have been serviced must be submitted on the DealerCONNECT Claim Entry Screen located on the Service tab. Claims submitted will be used by DaimlerChrysler to record recall service completions and provide dealer payments.

Use one of the following labor operation numbers and time allowances:

	Labor Operation Number	Time Allowance
Inspect shift interlock system operation and install load limiting shift lever push rod (<u>without</u> drilling shift lever dimple)	21-C4-51-82	0.2 hours
Inspect shift interlock system operation and install load limiting shift lever push rod (<u>with</u> drilling shift lever dimple)	21-C4-51-83	0.3 hours
Inspect shift interlock system operation and replace the shifter assembly (includes shift and interlock cable adjustment)	21-C4-51-84	0.6 hours

Add the cost of the recall parts package plus applicable dealer allowance to your claim.

NOTE: See the Warranty Administration Manual, Recall Claim Processing Section, for complete recall claim processing instructions.

Parts Return

Not required.

Dealer Notification and Vehicle List

All dealers will receive a copy of this dealer recall notification letter by DMAIL and by first class mail. Two additional copies will be sent through the DCMMS. DealerCONNECT will be updated to include this recall in the near future.

Vehicle Lists, Global Recall System, VIP and Dealer Follow up

All involved vehicles have been entered into the DealerCONNECT Global Recall System (GRS) and Vehicle Information Plus (VIP) for dealer inquiry as needed. Involved dealers were also mailed a copy of their vehicle (VIN) list with the dealer recall notification letter.

GRS provides involved dealers with an updated VIN list of their incomplete vehicles. The owner's name, address and phone number are listed if known. Completed vehicles are removed from GRS within several days of repair claim submission.

To use this system, click on the "Service" tab and then click on "Global Recall System." Your dealer's VIN list for each recall displayed can be sorted by: those vehicles that were unsold at recall launch, those with a phone number, city, zip code, or VIN sequence.

Dealers must perform this repair on all unsold vehicles before retail delivery. Dealers should also use the VIN list to follow up with all owners to schedule appointments for this repair.

Recall VIN lists may contain confidential, restricted owner name and address information that was obtained from the Department of Motor Vehicles of various states. Use of this information is permitted for this recall only and is strictly prohibited from all other use.

Owner Notification and Service Scheduling

All involved vehicle owners known to DaimlerChrysler are being notified of the service requirement by first class mail. They are requested to schedule appointments for this service with their dealers. A copy of the owner letter is attached.

Enclosed with each owner letter is an Owner Notification Form. The involved vehicle and recall are identified on the form for owner or dealer reference as needed.

Vehicle owners will be notified in six (6) phases. Refer to the chart below.

Phase	Model Year	Platform	Transmission	Shift Handle
1	1996-1997	JX	Standard Automatic / DG-	Cobra
2	1996-1999	JX	AutoStick / DHD	Cobra
	1996-1999	JA	AutoStick / DHD	Cobra
	1993-1997	LH	AutoStick / DHD	Cobra
3	1998-1999	JX	Standard Automatic / DG-	Cobra
	1998-1999	JA	Standard Automatic / DG-	Cobra
4	1998-1999	LH	AutoStick / DHD	Cobra
5	1998-1999	LH	Standard Automatic / DG-	Cobra
6	1995-1997	JA	Standard Automatic / DG-	T-Handle
	1993-1997	LH	Standard Automatic / DG-	T-Handle

Dealers are encouraged to consider alternative scheduling and servicing approaches for this recall. This repair does not require hoists or other full service facility special equipment and is a DaimlerChrysler Mobile Service approved repair.

Additional Information

If you have any questions or need assistance in completing this action, please contact your Service and Parts District Manager.

Customer Services Field Operations
DaimlerChrysler Corporation

DAIMLERCHRYSLER

SAFETY RECALL – TRANSAXLE FLOOR SHIFTER IGNITION/PARK INTERLOCK

Dear DaimlerChrysler Vehicle Owner:

This notice is sent to you in accordance with the requirements of the National Traffic and Motor Vehicle Safety Act.

DaimlerChrysler Corporation has decided that a defect, which relates to motor vehicle safety, exists in some of the following vehicles equipped with a floor mounted shifter and an automatic transaxle:

- 1993 through 1999 model year Chrysler Concorde, LHS and 300M, Dodge Intrepid and Eagle Vision
- 1995 through 1999 model year Chrysler Cirrus and Dodge Stratus
- 1996 through 1999 model year Chrysler Sebring Convertible and Plymouth Breeze

NOTE: *Some of the above vehicles were involved in a previous recall which did not fully correct the ignition/park interlock system.*

The problem is...

The transaxle floor shifter ignition/park interlock system on your vehicle (identified on the enclosed form) may become inoperative. This may allow the shifter to be moved out of the "Park" position with the ignition key removed (or in the "Lock" position). It may also allow the ignition key to be removed when the shifter has not been placed in the "Park" position. If the shifter is not in the "Park" position, these conditions could allow the vehicle to roll away and cause a crash without prior warning.

What DaimlerChrysler and your dealer will do...

DaimlerChrysler will repair your vehicle free of charge (parts and labor). To do this, your dealer will inspect the shift interlock system and either modify or replace the transaxle shifter as required. Shifter modification will take about ½ hour to complete. Shifter replacement, if necessary, will take about one hour. However, additional time may be necessary depending on how dealer appointments are scheduled and processed.

What you must do to ensure your safety...

- **Simply contact your dealer right away to schedule a service appointment.**
- **Bring the enclosed form with you to your dealer.** It identifies the required service to the dealer.

If you need help...

If you have questions or concerns which your dealer is unable to resolve, please contact DaimlerChrysler at 1-800-853-1403.

If you have already experienced this condition and have paid to have it repaired, you may send your original receipts and/or other adequate proof of payment to the following address for reimbursement: DaimlerChrysler, P.O. Box 610207, Port Huron, MI 48061-0207, Attention: Reimbursement.

If your dealer fails or is unable to remedy this defect without charge and within a reasonable time, you may submit a written complaint to the Administrator, National Highway Traffic Safety Administration, 400 Seventh Street, S.W., Washington, DC 20590, or call the toll-free Auto Safety Hotline at 1-888-327-4236.

We're sorry for any inconvenience, but we are sincerely concerned about your safety. Thank you for your attention to this important matter.

***Buckle up
for Safety***

Customer Services Field Operations
DaimlerChrysler Corporation
C45

Note to lessors receiving this recall: Federal regulation requires that you forward this recall notice to the lessee within 10 days.