

MOBILITYWORKS

ADAPTIVE VEHICLES

MAKING THE WORLD ACCESSIBLE

Date: November 22, 2004

Via DHL Express and Fax

Mr. George Person
Chief, Recall Management Division
National Highway Traffic Safety Administration
400 7th Street South West
Washington, DC 20590

04V-562
(12 pages)

Dear Mr. Person:

In response to The Recall Management Divisions's letter of October 18, 2004, and in accordance with 49 USC 30118 and 49 CFR Part 573, this is a report under 49 CFR 573.5 informing you that WMK, Inc. d/b/a MobilityWorks (MOBILITYWORKS) has determined that some MobilityWorks Ford E-150, E-250, E-350 vans and multi purpose passenger vehicles, and General Motors 1500, 2500, 3500 vans and multi purpose passenger vehicles, and Chrysler 1500, 2500, 3500 vans and multi purpose passenger vehicles manufactured or altered by MOBILITYWORKS and sold in the United States have been fitted with original equipment Sure-Lok Retractable wheelchair tie down assemblies that may be defective. This notice follows the Notice of Defect filed by Sure-Lok with NHTSA on August 4, 2004 under Part 573, in which Sure-Lok informed NHTSA that Sure-Lok component part number 8625-13 may have sprocket teeth in the retractor assembly that are out of alignment. A copy of the Sure-Lok letter to NHTSA is enclosed.¹

¹ MOBILITYWORKS is a constructor of vehicles for the mobility industry serving the needs of the disabled. We operate as a final stage manufacturer and alterer and also operate as a vehicle modifier, working on vehicles after first retail sale. As regards such modifier vehicles, there is clearly no question that MOBILITYWORKS has no recall responsibility.

This letter confirms that some vehicles manufactured or altered by MOBILITYWORKS were constructed with Sure-Lok tracking. However, no vehicles were manufactured or altered by MOBILITYWORKS with the Sure-Lok wheelchair securement retractor assemblies that are the subject of the Sure-Lok recall, part number 8625-13. MOBILITYWORKS does not install the Sure-Lok wheelchair securement retractor assemblies until after a retail sale of the vehicle, if and when the purchaser requests such retractors. Such installation is thus done by MOBILITYWORKS as a modifier. Significantly, other Sure-Lok retractors are available besides the model that is the subject of the recall, and these other retractors fit the track installed by MOBILITYWORKS during the vehicle manufacturing process. Vehicle owners have the option to choose these other retractors, and in fact do so choose. Given this set of facts, the subject retractors provided by MOBILITYWORKS are over-the-counter retail parts sales and post-retail sale modifier-installed equipment. In each of these two situations, the responsibility for the recall lies only with the equipment manufacturer. In addition, the Sure-Lok retractors that are the subject of the current Sure-Lok are devices that are not permanently attached to the vehicle, are readily removable, and can be -- and routinely are-- moved from vehicle to vehicle. Analogous equipment would be an FMVSS 125 warning device which can be moved by the vehicle owner from vehicle to vehicle. The same is true as regards bicycle or ski racks which can be moved from vehicle to vehicle.

Notwithstanding the above, because NHTSA believes that a recall by MOBILITYWORKS is appropriate, we are filing this notice and implementing the requested recall.

Pursuant to 49 CFR 573.5(c), MOBILITYWORKS provides the following information (per 49 CFR 573.5(b), new and/or updated information will be submitted as it is available):

1. **Vehicle Manufacturer's name:**
WMK Inc., d/b/a MobilityWorks
1090 West Wilbeth Road
Akron, Ohio 44314
Contact person:
Ralph Cartellone, VP Operations
Tel. 800 769 8267
Fax 330-861-0283
MobilityWorks is both a Final Stage Manufacturer under 49 CFR 567.5, as well as an Alterer under 49 CFR 567.7.
2. **Identification of vehicles potentially containing the defective OEM Sure-Lok equipment:** MY 1997 through 2004 MobilityWorks Ford E-150, E-250, E-350 vans and multi purpose passenger vehicles, and General Motors 1500, 2500, 3500 vans and multi purpose passenger vehicles, and Chrysler 1500, 2500, 3500 vans and multi purpose passenger vehicles. Vehicle manufacture dates are from 01-01-1997 through 08-01-2004.
Description of basis of determination of recall population:
MOBILITYWORKS has been informed by Sure-Lok that certain Sure-Lok equipment fitted as OEM equipment on MOBILITYWORKS vehicles may be defective. As a result of this information, MOBILITYWORKS has determined that certain vehicles manufactured by MOBILITYWORKS and sold in the United States and fitted with original equipment Sure-Lok Retractable wheelchair tie down assemblies may be defective.
3. **Total number of US vehicles potentially containing the defect:** The number of MOBILITYWORKS vehicles manufactured or altered and sold in the USA that could have been sold with the defective retractor potentially totals 1660.
4. **The percentage of vehicles specified in #3 above estimated to contain the defect:** Less than 1% based on information from Sure-Lok
5. **Description of the defect:** According to Sure-Lok, Sure-Lok component part number 8625-13 may have sprocket teeth in the retractor assembly that are out of alignment. See attached Sure-Lok Safety bulletin.
6. **Data on which determination of defect was made:** Information from Sure-Lok. There are no known accidents, crashes, or injuries.
7. N/A.

8. **Description of program for remedying the defect:**
- MOBILITYWORKS has contacted Sure-Lok and Sure-Lok has agreed that MOBILITYWORKS shall supply Sure-Lok a complete Customer and Dealer list identifying the names and addresses of Customers and Dealers that may have received the defective retractors. Sure-Lok will implement a recall on MOBILITYWORKS' behalf which recall shall include supplying the instructions and inspection procedure to MOBILITYWORKS Customers and Dealers, administrating the inspection procedure, and replacing any defective retractors at no cost to the Customer or Dealer.
 - Sure-Lok will notify the dealers and vehicle owners in MOBILITYWORKS' records.
 - Sure-Lok will conduct the recall free of charge (assuming within the statutory 10 year period).
 - Sure-Lok will implement the recall in accordance with the attached Sure-Lok bulletin. Sure-Lok, through its administrative process, will also reimburse any owner who is eligible for reimbursement under Part 573 where the customer has already paid to replace the defective part.

Estimated date on which Sure-Lok will begin sending notifications to MOBILITYWORKS Customers and Dealers: Owners letters and Dealers notifications will be mailed first class mail starting 12-03-2004.

Estimated date on which Sure-Lok will complete such notification:
12-17-2004.

9. **Copies of all notices, bulletins, and other communications that relate to the noncompliance and sent to more than one dealer or purchaser:**
The draft Dealer bulletin is attached.
10. **Draft Owner notification letter is attached.**
11. **Manufacturer's campaign number:** MOBILITYWORKS will use the number assigned by NHTSA, or the Sure Lok number 04E-058.

Respectfully submitted,

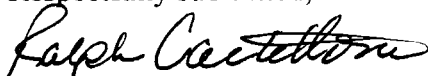

MobilityWorks
Ralph Cartellone
VP Operations

MOBILITYWORKS

ADAPTIVE VEHICLES
MAKING THE WORLD ACCESSIBLE

DRAFT DEALER NOTIFICATION LETTER

BY FIRST CLASS MAIL

DATE: November 22, 2004

TO: All MobilityWorks Locations
All MobilityWorks Dealers

Attn: Service Manager / Warranty Administrator

SUBJECT: SAFETY RECALL NOTICE – MY 1997 to 2004 MobilityWorks vehicles equipped with Sure-Lok Retractable Wheelchair Tie Down Assemblies

MobilityWorks has decided that a defect which relates to motor vehicle safety exists in MobilityWorks vehicles of model years 1997 through 2004 equipped with certain Sure-Lok wheelchair securement retractor assemblies. Sure-Lok informed both NHTSA and MobilityWorks that Sure-Lok component part number 8625-13 may have sprocket teeth in the retractor assembly that are out of alignment.

You are being informed of this recall for two reasons:

1. So that you can inspect any MobilityWorks vehicles in your unsold inventory and contact Sure-Lok if any retractors are defective;
2. So that you can direct vehicle owners to Sure-Lok for performance of the recall (customers are being notified by Sure-Lok on behalf of MobilityWorks).

NOTE: it is a violation of Federal law for a dealer to deliver a new motor vehicle or any new or used item of motor vehicle equipment covered by the notification under a sale or lease until the defect or noncompliance is remedied.

A description of the defect in the Sure-Lock Retractable Wheelchair Tie Down Assemblies is as follows (**A COPY OF THE SURE-LOK RECALL BULLETIN IS ALSO ATTACHED FOR YOUR INFORMATION**)--

(1) the particular item(s) of motor vehicle equipment affected: Sure-Lock wheelchair securement retractor assemblies, component part number 8625-13 may have sprocket teeth in the retractor assembly that are out of alignment.

(2) the malfunction that may occur as a result of the defect or noncompliance: if the sprocket teeth of the retractor assembly are out of alignment, this could cause the load pawl not to properly seat in two sprockets simultaneously, causing the sprocket teeth not to hold as they are designed to.

The defect will not cause a vehicle crash, but in the event of a crash, the defect securement system might not support the wheelchair in a crash, a situation which could cause serious injury or death.

The measures to be taken to remedy the defect are as follows:

(i) Sure-Lok, on MobilityWorks' behalf, will cause such defect to be remedied without charge, and such remedy will involve an inspection of the Sure-Lok securement system and replacement of it if found to be defective.

(ii) The earliest date on which the defect will be remedied without charge will be immediately.

(iii) VEHICLE OWNERS ARE BEING INFORMED (SEE ATTACHED SAMPLE OWNER LETTER) TO ***CONTACT SURE-LOK DIRECTLY AT 866-787-3565, CUSTOMER SERVICE.***

Please note that if a customer already replaced a Sure-Lok securement system due to the defect specified herein, he or she may be entitled, under certain circumstances to reimbursement. If this situation applies, contact Sure-Lok.

If you have any questions, please contact

**Sure-Lok, Inc.
Customer Service
866-787-3565**

Attachments:

Sure-Lok Safety Bulletin
Affected Part Number List
MobilityWorks Owners Letter



DRAFT MOBILITYWORKS CUSTOMER LETTER

BY FIRST CLASS MAIL

Owner Name
Address line 1
Address line 2
City, State
Zip

RE: SAFETY RECALL re Model Year 1997 through 2004 MobilityWorks Vans and Multi Purpose Passenger Vehicles Equipped With Sure-Lok Retractable Wheelchair Tie Down Assemblies

Dear MobilityWorks Vehicle Owner:

This notice is sent to you in accordance with the requirements of the National Traffic and Motor Vehicle Safety Act. MobilityWorks has decided that a defect which relates to motor vehicle safety exists in MobilityWorks vehicles of model years 1997 through 2004 equipped with certain Sure-Lok wheelchair securement retractor assemblies. YOUR VEHICLE may be affected, although not all Sure-Lok restraints are defective.

A description of the defect in the Sure-Lok wheelchair securement retractor assemblies is as follows--

(1) the particular item(s) of motor vehicle equipment affected: Sure-Lok wheelchair securement retractor assemblies, component part number 8625-13 may have sprocket teeth in the retractor assembly that are out of alignment.

(2) the malfunction that may occur as a result of the defect or noncompliance: if the sprocket teeth of the retractor assembly are out of alignment, this could cause the load pawl not to properly seat in two sprockets simultaneously, causing the sprocket teeth not to hold as they are designed to.

The defect will not cause a vehicle crash, but in the event of a crash, the defect securement system might not support the wheelchair in a crash, a situation which could cause serious injury or death.

The measures to be taken to remedy the defect are as follows:

(i) Sure-Lok, on MobilityWorks' behalf, will cause such defect to be remedied without charge, and such remedy will involve an inspection of the Sure-Lok securement system and replacement of it if found to be defective.

(ii) The earliest date on which the defect will be remedied without charge will be immediately.

(iii) **CONTACT SURE-LOK CUSTOMER SERVICE DIRECTLY at 866-787-3565** and they will assist you in the inspection process in accordance with the attached Sure-Lok Safety Bulletin.

You may submit a complaint to the Administrator, National Highway Traffic Safety Administration, 400 Seventh Street, SW., Washington, DC 20590 or call the toll free Auto Safety Hotline at 800-424-9393 (Washington, DC area residents may call 202-366-0123), if you believe that:

(A) MobilityWorks or Sure-Lok or their dealer has failed or is unable to remedy the defect without charge.

(B) MobilityWorks or Sure-Lok or their dealer has failed or is unable to remedy the defect without charge within a reasonable time, which is not longer than 60 days in the case of repair after your first tender to obtain repair following the earliest repair date specified in this notification.

Please note that if you already replaced a Sure-Lok securement system due to the defect specified herein, you may be entitled, under certain circumstances to reimbursement. If this situation applies to you, contact Sure-Lok Customer Service at 866-787-3565.

Any Lessor that receives this notification must send a copy of this notice to the Lessee.

Any Dealer that receives this notification must send a copy of this notice to the Customer.

We are sorry for this inconvenience; however, we have taken this action in the interest of your safety and continued satisfaction with our products. If you have any questions, please contact Sure Lok, Inc. at 866-787-3565.

Enclosure:

Sure-Lok Safety Bulletin
Affected Part Number List

Owner Name
Address line 1
Address line 2
City, State
Country Zip

SAFETY RECALL NOTICE

Sure-Lok Retractable Wheelchair Tie-Down Assembly Recall

The following Sure-Lok part numbers, which contain the affected component part number 8625-13, are affected by this recall. These part numbers can be found on the product box or on the tag sewn onto the retractable wheelchair tie-down assembly.

FE200823	FE200823S	FE200824	FE200824S
FE200825	FE200825S	FE200826	FE200826S
FE200827S	FE200828	FE200828S	FE200855
FE200855S	FE200857	FE200857S	FE200907
FE200907S	FE200925	FE200925S	FE200944
FE200944S	FE200945S	FF612S	FF612S-4C
FF615-4C	FF615S	FF615S-4C	FF627-4C
FF627S	FF627S-4C	FF628	FF628S
FF628S-4C	FF661S-4C		



Safe and Secure

SAFETY BULLETIN

NHTSA RECALL #04E058

Page 1 of 3

August 16, 2004

There is a possibility of a component related defect in Sure-Lok retractable wheelchair tie-down assemblies. It has been identified in only a few retractor assemblies; however, the potential for serious injury is sufficient to warrant this alert. This safety bulletin affects all retractable wheelchair tie-down assemblies shipped through July 2004.

The component defect places the sprocket teeth of the retractor assembly out of alignment, causing the load pawl to not fully seat in the sprocket teeth. **ALL retractable wheelchair tie-down assemblies must be inspected for this potential condition.** See instructions below. Any retractor, which meets the defined criteria, needs to be removed from service immediately and returned to Sure-Lok for replacement at no charge. Contact Customer Service at 866-787-3565 for further instructions.

Instructions for Inspecting Retractors

Retractor Operation:

Each retractor assembly has a load pawl that engages into two sprockets (one on each side). As the retractor strap is wound into the case, the load pawl ratchets or clicks into the teeth of the sprockets. On units that have the proper alignment (phasing) of the sprockets, the load pawl clicks into and seats in both sprockets simultaneously. On these units, there are 24 teeth encountered on one full rotation of the retractor knob.

On units that exhibit the identified alignment or phase problem, the load pawl does not seat in both sprockets simultaneously, but encounters the sprocket teeth on one sprocket and then the other in succession. One full rotation of the retractor knob will click through 48 teeth (24 teeth for each sprocket) on these units.

SURE-LOK

Safe and Secure

SAFETY BULLETIN

Page 2 of 3

Inspecting Units That Have A Retractor Knob:

Release the retractor strap and pull approximately 1 foot of webbing from the retractor. Position the retractor knob so that one of the lugs on the knob is at the 12:00 o'clock position. Slowly rotate the retractor knob one-quarter rotation (90 degrees) and count the clicks as the load pawl encounters the sprocket teeth. Units that are out of phase and require replacement will have 12 clicks. Contact Sure-Lok customer service at 866-787-3565.

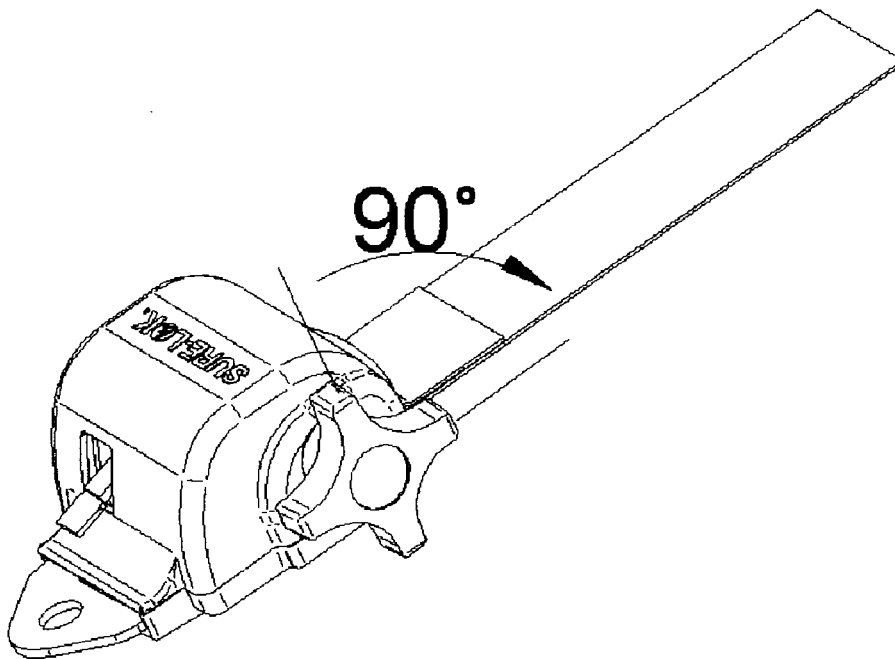

Rotate the knob ¼ turn as shown in the picture and count the clicks

6 clicks identifies a properly functioning retractor

12 clicks identifies a defective unit that requires replacement

SURE-LOK

Safe and Secure

SAFETY BULLETIN

Page 3 of 3

Inspecting Units That Do Not Have A Retractor Knob:

Fully extend the webbing from the retractor, and measure $\frac{3}{4}$ inch from the entrance throat of the retractor. Draw a line on the webbing at this point $\frac{3}{4}$ inch from the entrance throat of the retractor. While holding the extended webbing taut, slowly depress the release lever to the point that it just releases the web.

Allow the webbing to be drawn into the retractor until the mark that you made is at the entrance of the retractor housing. Go slowly, one ratchet step at a time while counting the feel of ratchet clicks. It is necessary to let the release lever ride over the top of the sprocket teeth to feel the clicks. There should be the feel of six ratchet clicks encountered for a $\frac{3}{4}$ inch length of webbing. 12 clicks over the $\frac{3}{4}$ inch span of webbing indicates a defective retractor which needs to be removed from service immediately. Contact Sure-Lok customer service at 866-787-3565.

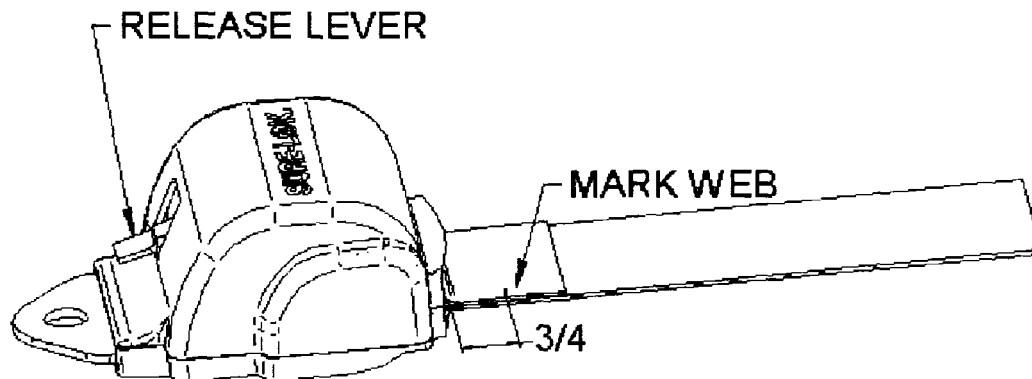

6 clicks to retract $\frac{3}{4}$ " of fully-extended web identifies a properly functioning retractor
12 clicks to retract $\frac{3}{4}$ " of fully-extended web identifies a defective unit that requires replacement