

**VAN**

**WHEELCHAIR VANS, AMBULANCES AND BUSES**

RECEIVED  
SEP 30 A 11:21  
DEFECT INVESTIGATION

September 23, 2004

Associate Administrator for Enforcement  
NHTSA  
Washington, DC 20590

**VIA CERTIFIED MAIL, RETURN RECEIPT REQUESTED**

Re: Part 573 Defect and Noncompliance Report

04V-450  
(13 pages)

Dear Sir or Madam:

Please find enclosed a completed Part 573 Defect and Noncompliance Report and all supporting documentation. Kindly process this information accordingly.

Should you have any questions or require additional information, please contact me directly. Thank you for your assistance.

Very truly yours,

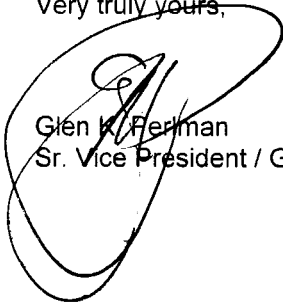

Glen K. Fedman  
Sr. Vice President / General Counsel

Safety Defect and Noncompliance Report Guide for Vehicles  
**PART 573 Defect and Noncompliance Report<sup>1</sup>**

On August 20, 2004, National Van Builders, Inc. [MFR] decided that (a defect which relates to motor vehicle safety) (a noncompliance with Federal Motor Vehicle Safety Standard No. \_\_\_\_\_) exists in the motor vehicles listed below, and is furnishing notification to the National Highway Traffic Safety Administration in accordance with 49 CFR Part 573 Defect and Noncompliance Reports.

Date this report was prepared: August 25, 2004

Furnish the manufacturer's identification code for this recall (if applicable): 04E058

1. Identify the full corporate name of the fabricating manufacturer of the vehicle being recalled. If the recalled vehicle is imported, provide the name and mailing address of the designated agent as prescribed by 49 U.S.C. §30164.

National Van Builders, Inc.

Identify the corporate official, by name and title, whom the agency should contact with respect to this recall.

Glen Perlman  
Senior Vice President/General Counsel

Telephone Number: 508-222-2272 Fax No.: 508-222-7882

Name and Title of Person who prepared this report.

Glen Perlman  
Sr. Vice President

Signed:

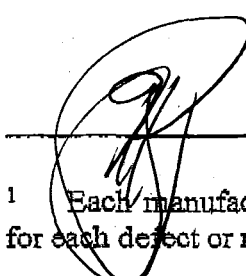
  
\_\_\_\_\_  
<sup>1</sup> Each manufacturer must furnish a report, to the Associate Administrator for Safety Assurance, for each defect or noncompliance condition which relates to motor vehicle safety.

This guide was developed from 49 CFR Part 573, "Defect and Noncompliance Reports" and also outlines information currently requested. Any questions, please consult the complete Part 573 or contact Mr. George Person at (202) 366-5210 or by FAX at (202) 366-7882.

**I. Identify the Vehicle Models Involved in the Recall**

**2. Identify the Vehicles Involved in the Recall, for each make and model or applicable vehicle line (provide illustrations or photographs as necessary to describe the vehicle), provide:**

Make(s): Ford Model Years Involved: 2002-2004 Model(s): Econoline  
Production Dates: Beginning: 12/31/02 Ending: 7/31/04  
VIN Range: Beginning: \_\_\_\_\_ Ending: \_\_\_\_\_  
Vehicle Type: Van Bodystyle: \_\_\_\_\_

**Descriptive information which characterizes/distinguishes the recalled vehicles from those model vehicles not included in the recall:**

Vehicles sold through July, 2004 equipped with Sure-Lok brand retractable wheelchair tiedown equipment

Make(s): \_\_\_\_\_ Model Years Involved: \_\_\_\_\_ Model(s): \_\_\_\_\_  
Production Dates: Beginning: \_\_\_\_\_ Ending: \_\_\_\_\_  
VIN Range: Beginning: \_\_\_\_\_ Ending: \_\_\_\_\_  
Vehicle Type: \_\_\_\_\_ Bodystyle: \_\_\_\_\_

**Descriptive information which characterizes/distinguishes the recalled vehicles from those model vehicles not included in the recall:**

Make(s): \_\_\_\_\_ Model Years Involved: \_\_\_\_\_ Model(s): \_\_\_\_\_  
Production Dates: Beginning: \_\_\_\_\_ Ending: \_\_\_\_\_  
VIN Range: Beginning: \_\_\_\_\_ Ending: \_\_\_\_\_  
Vehicle Type: \_\_\_\_\_ Bodystyle: \_\_\_\_\_

**Descriptive information which characterizes/distinguishes the recalled vehicles from those model vehicles not included in the recall:**

**Identify the approximate percentage of the production of all the recalled models manufactured by your company between the inclusive dates of manufacture provided above, that the recalled model population represents. For example, if the recall involved Widgets equipped with certain items of equipment from January 1, 1996 through April 1, 1997, then what was the percentage of the recalled Widgets of all Widgets manufactured during that time period.**

**II. Identify the Recall Population**

**3. Furnish the total number of vehicles recalled potentially containing the defect or noncompliance.**

<b><u>Vehicles</u></b>		<b><u>Year</u></b>	<b><u>2002-2004</u></b>	<b><u>Number of</u></b>
<b><u>Model</u></b>	<b><u>Econoline</u></b>			<b><u>Potentially</u></b>
<b><u>Involved</u></b>				20

**Total Number Potentially Affected by the Recall:** 20

**4. Furnish the approximate percentage of the total number of vehicles estimated to actually contain the defect or noncompliance:** Unknown

**Identify and describe how the recall population was determined--in particular how the recalled models were selected and the basis for the beginning and final dates of manufacture of the recalled vehicles:**

National Van Builders recall is being issued pursuant to  
a recall notice received from Sure-Lok, Inc. On August 20, 2004  
Sure-Lok Inc, is the manufacture of the potentially defective  
component. A copy of such recall notice is attached.

**III. Describe the Defect or Noncompliance**

**5. Describe the defect or noncompliance. The description should address the nature and physical location of the defect or noncompliance. Illustrations should be provided as appropriate.**

Sure-Lok brand retractable wheelchair securement equipment  
manufactured through July, 2004. Please see attached recall  
notice & diagrams from Sure-Lok, Inc.

**Describe the cause(s) of the defect or noncompliance condition.**

Component defect in equipment

**Describe the consequence(s) of the defect or noncompliance condition.**

Possible failure of wheelchair securement system

**Identify any warning which can (a) precede or (b) occur.**

Unknown

**If the defect or noncompliance is in a component or assembly purchased from a supplier, identify the supplier by corporate name and address.**

Sure-Lok, Inc.

151 Industrial Parkway

Branchburg, NJ 08876-3451

**Identify the name and title of the chief executive officer or knowledgeable representative of the supplier:**

Dana Yarnell Quality Assurance Manager

**IV. Provide the Chronology in Determining the Defect/Noncompliance**

*If the recall is for a defect, complete item 6, otherwise item 7.*

**6. With respect to a defect, furnish a chronological summary (including dates) of all the principle events that were the basis for the determination of the defect. The summary should include, but not be limited to, the number of reports, accidents, injuries, fatalities, and warranty claims. Please see recall notice of Sure-Lok, Inc**

**7. With respect to a noncompliance, identify and provide the test results or other data (in chronological order and including dates) on which the noncompliance was determined.**

Please see recall notice of Sure-Lok Inc

---

---

---

---

---

**V. Identify the Remedy**

**8. Furnish a description of the manufacturer's remedy for the defect or noncompliance. Clearly describe the differences between the recall condition and the remedy.**

Defective equipment to be replaced free of charge by

---

Sure-Lok, Inc. National Van Builders, Inc. to assist in  
facilitating replacements for its customers as required.

---

---

**Clearly describe the distinguishing characteristics of the remedy component/assembly versus the recalled component/assembly.**

Non-Defective equipment produced by Sure-Lok, Inc.

---

---

---

Identify and describe how and when the recall condition was corrected in production. If the production remedy was identical to the recall remedy in the field, so state. If the product was discontinued, so state.

Please see recall notice of Sure-Lok, Inc.

---

---

---

---

---

**VI. Identify the Recall Schedule**

Furnish a schedule or agenda (with specific dates) for notification to other manufacturers, dealers/retailers, and purchasers. Please, identify any foreseeable problems with implementing the recall.

All customers of National Van Builders, Inc. who may be affected by the recall to be notified via mail by September 30, 2004

---

---

---

---

---

**VII. Furnish Recall Communications**

9. Furnish a final copy of all notices, bulletins, and other communications that relate directly to the defect or noncompliance and which are sent to more than one manufacturer, distributor, or purchaser. This includes all communications (including both original and follow-up) concerning this recall from the time your company determines the defect or noncompliance condition on, not just the initial notification. *A DRAFT copy of the notification documents should be submitted to this office by Fax (202-366-7882) for review prior to mailing.*

Note that these documents are to be submitted separately from those provided in accordance with Part 573.8 requirements.

# VAN

## WHEELCHAIR VANS, AMBULANCES AND BUSES

### RECALL NOTICE SURE-LOK RETRACTABLE WHEELCHAIR TIE-DOWNS

September 23, 2004

Dear Customer:

This letter is being sent to you in accordance with the requirements of the National Traffic and Motor Vehicle Safety Act.

National Van Builders, Inc. has been notified by Sure-Lok, Inc. of a defect that relates to motor vehicle safety exists in its Wheelchair Securement Retractor Assemblies.

This defect may result in failure of the Tie-Down to secure a wheelchair during a crash. This recall pertains to all *retractable* wheelchair tie-down assemblies. Non-retractable assemblies are not affected.

Because this defect relates to motor vehicle safety, it is extremely important that each Retractable Wheelchair Tie-Down be inspected in accord with the instructions contained in the enclosed Sure-Lok Safety Bulletin. Please read and follow the instructions for inspection contained in the Safety Bulletin. Following these instructions will ensure that the problem does not occur regarding your Sure-Lok wheelchair securement systems.

Any defective parts will be replaced by Sure-Lok at no cost. You may contact Sure-Lok directly as set forth in the attached Bulletin, or National Van Builders to facilitate replacement. In the event that you have already paid for replacement of the defective part, Sure-Lok will reimburse you.

If this recall and remedy are not completed to your satisfaction, you may contact the Administrator, National Highway Traffic Safety Administration, 400 Seventh Street SW, Washington, DC 20590 or call the toll-free Auto Safety Hotline at 888 327 4236 and reference NHTSA Recall # NVB/Sure-Lok/2004.

We sincerely appreciate your business and apologize for any inconvenience this recall may have caused. Please feel free to contact me directly at 800 527 7477 with any questions or concerns.

Very truly yours,

  
Glen K. Perlman  
Sr. Vice President / General Counsel

Enc: Sure-Lok Safety Bulletin 08/04

**VAN**

**WHEELCHAIR VANS, AMBULANCES AND BUSES**

80 Pine Street, Attleboro, Massachusetts 02703

Sample Notification  
100 Sample Street  
Sample, MA 02545

**SAFETY RECALL NOTICE**

SAMPLE  
ENVELOPE



Sure-Lok, Inc.  
151 Industrial Parkway  
Branchburg, NJ 08876-3451  
Tel 908 231-1804  
Fax 908 231-6887  
www.sure-lok.com

AUG 20 2004

August 16, 2004

Dear Valued Customer:

This notice is sent to you in accordance with the requirements of the National Traffic and Motor Vehicle Safety Act.

Sure-Lok, Inc. has decided that a defect which relates to motor vehicle safety exists in its Wheelchair Securement Retractor Assemblies. While this defect only occurs in a small number of the retractor assemblies, it needs to be addressed.

The description of the defect is set forth in the attached Safety Bulletin. As long as this malfunction exists, the wheelchair may not be secured during a crash. Following the instructions set forth in the attached Safety Bulletin will ensure that the problem does not occur regarding your Sure-Lok wheelchair securement systems.

If the system is not checked as the Safety Bulletin instructs, then in a crash the wheelchair could possibly not be secured resulting in injury to the wheelchair passenger.

If you identify a defective retractor assembly, it should be returned to us as instructed. Sure-Lok, Inc. will replace the defective part at no cost. (In the event you have already paid for a replacement of the defective part, Sure-Lok will reimburse you.)

If the above-mentioned recall and remedy are not completed to your satisfaction, you may contact the Administrator, National Highway Traffic Safety Administration, 400 Seventh Street SW, Washington, DC 20590 or call the toll free Auto Safety Hotline at 888-327-4236 and reference NHTSA Recall #04E058.

We appreciate your business and truly regret any inconvenience that this recall may cause you. Should you require more specific information, contact Sure-Lok Customer Service at 866-787-3565.

Sincerely,

Dana Yarnell, CQM, CQE, CQA  
Quality Assurance Manager

Attachment: Safety Bulletin 08/04 (3 pages) re NHTSA Recall #04E058

# **SURE-LOK**

Safe and Secure

## **SAFETY BULLETIN NHTSA RECALL #04E058 Page 1 of 3**

August 16, 2004

There is a possibility of a component related defect in Sure-Lok retractable wheelchair tie-down assemblies. It has been identified in only a few retractor assemblies; however, the potential for serious injury is sufficient to warrant this alert. This safety bulletin affects all retractable wheelchair tie-down assemblies shipped through July 2004.

The component defect places the sprocket teeth of the retractor assembly out of alignment, causing the load pawl to not fully seat in the sprocket teeth. **ALL retractable wheelchair tie-down assemblies must be inspected for this potential condition.** See instructions below. Any retractor, which meets the defined criteria, needs to be removed from service immediately and returned to Sure-Lok for replacement at no charge. Contact Customer Service at 866-787-3565 for further instructions.

### **Instructions for Inspecting Retractors**

#### **Retractor Operation:**

Each retractor assembly has a load pawl that engages into two sprockets (one on each side). As the retractor strap is wound into the case, the load pawl ratchets or clicks into the teeth of the sprockets. On units that have the proper alignment (phasing) of the sprockets, the load pawl clicks into and seats in both sprockets simultaneously. On these units, there are 24 teeth encountered on one full rotation of the retractor knob.

On units that exhibit the identified alignment or phase problem, the load pawl does not seat in both sprockets simultaneously, but encounters the sprocket teeth on one sprocket and then the other in succession. One full rotation of the retractor knob will click through 48 teeth (24 teeth for each sprocket) on these units.

# SURE-LOK

Safe and Secure

## SAFETY BULLETIN

Page 2 of 3

### Inspecting Units That Have A Retractor Knob:

Release the retractor strap and pull approximately 1 foot of webbing from the retractor. Position the retractor knob so that one of the lugs on the knob is at the 12:00 o'clock position. Slowly rotate the retractor knob one-quarter rotation (90 degrees) and count the clicks as the load pawl encounters the sprocket teeth. Units that are out of phase and require replacement will have 12 clicks. Contact Sure-Lok customer service at 866-787-3565.

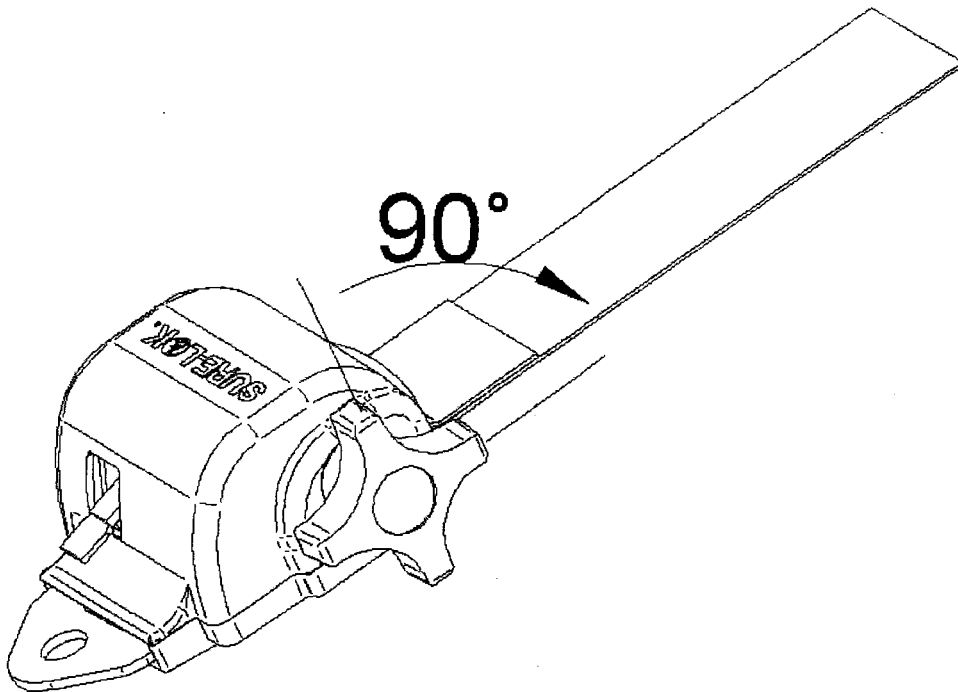

**Rotate the knob  $\frac{1}{4}$  turn as shown in the picture and count the clicks**

6 clicks identifies a properly functioning retractor

12 clicks identifies a defective unit that requires replacement

# SURE-LOK

Safe and Secure

## SAFETY BULLETIN

Page 3 of 3

### Inspecting Units That Do Not Have A Retractor Knob:

Fully extend the webbing from the retractor, and measure  $\frac{3}{4}$  inch from the entrance throat of the retractor. Draw a line on the webbing at this point  $\frac{3}{4}$  inch from the entrance throat of the retractor. While holding the extended webbing taut, slowly depress the release lever to the point that it just releases the web.

Allow the webbing to be drawn into the retractor until the mark that you made is at the entrance of the retractor housing. Go slowly, one ratchet step at a time while counting the feel of ratchet clicks. It is necessary to let the release lever ride over the top of the sprocket teeth to feel the clicks. There should be the feel of six ratchet clicks encountered for a  $\frac{3}{4}$  inch length of webbing. 12 clicks over the  $\frac{3}{4}$  inch span of webbing indicates a defective retractor which needs to be removed from service immediately. Contact Sure-Lok customer service at 866-787-3565.

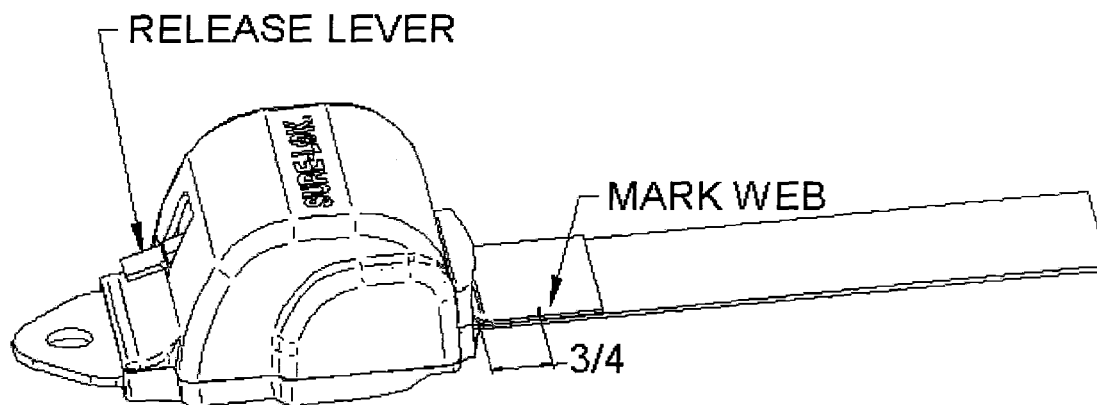

6 clicks to retract  $\frac{3}{4}$ " of fully-extended web identifies a properly functioning retractor  
12 clicks to retract  $\frac{3}{4}$ " of fully-extended web identifies a defective unit that requires replacement