



MONACO
COACH CORPORATION

RECEIVED
2004 FEB 25

2004 FEB 25 P 3 40

OFFICE OF
DEFECTS INVESTIGATION

February 16, 2004

CERTIFIED MAIL
RETURN RECEIPT REQUESTED

04V-080 ① of ⑦

Associate Administrator for Enforcement
National Highway Traffic Safety Administration
U.S. Department of Transportation
400 Seventh Street SW
Washington, DC 20590

Dear Associate Administrator:

Pursuant to 49 CFR Part 573, Monaco Coach Corporation ("Monaco" or the "Company") is submitting this report to NHTSA concerning a recall campaign, which is being voluntarily initiated. Specific information is as follows:

573.5(c)(2)

Affected vehicles are specific model year:

- 2004 Holiday Rambler - Ambassador, Imperial and Scepter, Class A Motor Homes**
- 2004 Monaco - Windsor and Signature Class A Motor Homes**

The affected units were manufactured between February 7, 2003 and November 20, 2003. The recall population was determined from information provided by Villa International and confirmed by the manufacturing records for the Company's manufacturing plants in Coburg, Oregon and Wakarusa, Indiana, which produced the affected motor homes.

573.5(c)(3)

A total of Three Hundred and Fifty Eight (358) motor homes are in the recall population. Specific Monaco/Holiday Rambler Serial Number and VIN break points are as follows:

2004 Holiday Ambassador 1 coach - with Serial Number of 040119053883400-142170 and VIN of 1RF62464042028132.

2004 Holiday Rambler Scepter with a starting Serial Number of 040119163883301-138123 ending with 040119164083400-143042, a starting VIN of 1RF42454642025244 ending with 1RF43564582028888.

2004 Holiday Rambler Imperial with a starting Serial Number of 040119544083301-138258 ending with 040119544083400-143223, a starting VIN of 1RF43564142025315 ending with 1RF43564642028968.

2004 Monaco Windsor with a starting Serial Number of 040120704083301-139212 ending with 040120704083400-143231, a starting VIN of 1RF43564742026193 ending with 1RF43564542028976.

2004 Monaco Signature with a starting Serial Number of 041020744253401-603559 ending with 041020744553401-603970, a starting VIN of 1RF18561041026455 ending with 1RF18571641028872.

573.5(c)4

Monaco has determined by information provided by Villa International that all of the motor homes in this recall population need to have the repair performed.

573.5(c)5

Monaco Coach Corporation was informed by Villa International (Villa) that the seat belt buckle anchorage on the Driver/Passenger seats can separate from the seat frame before full load. The affected units fail to conform to 49 CFR 571.207/210 "Mounting of Driver and Passenger Seat Assembly."

573.5(c)6

Monaco is currently not aware and has not been informed by Villa International of any casualties or losses related to this issue.

573.5(c)8

The remedy will involve the installation of a reinforcement bushing and a grade 5 bolt to the seatbelt anchorage system on both the driver and passenger seats.

All motor homes in Monaco's inventory have been corrected.

Copies of the owner and dealer notification letters and the repair instructions are enclosed for your pre-approval. The Company is prepared to begin owner notification immediately.

Please acknowledge receipt of this defect information report and provide the recall number that will be assigned by NHTSA to this campaign.

Thank you for your assistance.

Sincerely,



Chuck R. Zucker
Technical Coordinator Supervisor
Monaco Coach Corporation

crz/tt



MONACO
COACH CORPORATION

February 16, 2004

VEHICLE SAFETY DEFECT SERVICE BULLETIN

Recall Campaign No. TBD

Monaco File # R04001

Re: Recall-Villa International Belt Buckle Mount

Dear Monaco Coach Corporation Dealer:

Monaco Coach Corporation has been notified by Villa International that certain **2004 Holiday Rambler Ambassador, Scepter, Imperial, and 2004 Monaco Windsor and Signature Class A** motor homes fail to conform to 49 CFR 571.207/210 "Mounting of Driver and Passenger Seat Assembly", specifically the seat belt mounting to the seat frame. *Federal law requires that any vehicle lessor receiving this recall notice must forward a copy of this notice to the lessee within ten days.*

The National Traffic and Motor Vehicle Safety Act provides that each vehicle that is subject to a recall campaign of this type must be adequately repaired within a reasonable time after the owner has tendered it for repair. Generally, failure to repair within sixty (60) days after the owner's first delivery for repair is assumed to be an unreasonable delay.

THE ISSUE

Villa International has made Monaco Coach aware that the seat belt buckle anchorage can separate from the seat frame before full load.

AFFECTED UNITS

2004 Holiday Ambassador – 1 coach –with Serial Number of 040119053883400-142170 and a VIN of 1RF62464042028132.

2004 Holiday Rambler Scepter with a starting Serial Number of 040119163883301-138123 ending with 040119164083400-143042, a starting VIN of 1RF42454642025244 ending with 1RF43564582028888.

2004 Holiday Rambler Imperial with a starting Serial Number of 040119544083301-138258 ending with 040119544083400-143223, a starting VIN of 1RF43564142025315 ending with 1RF43564642028968.

2004 Monaco Windsor with a starting Serial Number of 040120704083301-139212 ending with 040120704083400-143231, a starting VIN of 1RF43564742026193 ending with 1RF43564542028976.

2004 Monaco Signature with a starting Serial Number of 041020744253401-603559 ending with 041020744553401-603970, a starting VIN of 1RF18561041026455 ending with 1RF18571641028872.

If our records indicate that you have any of the affected vehicles in your inventory, you will also receive an owner notification letter identifying those units. Upon request, a list is available of the units that we currently show open in your dealer inventory.

THE REPAIR

The correction will involve the installation of a reinforcement bushing and grade 5 bolt to the seatbelt anchorage system on both the driver and passenger seats. This will be performed with no cost to the owners. The labor operation code and labor time allowance are included in the Recall Repair Instructions. The parts are readily available by faxing the enclosed Recall Parts Purchase Order to 1-800-498-9478. If you have any questions concerning the repair procedure, please contact a member of our Technical Support staff toll free at 877-332-9239.

DEALER CAMPAIGN RESPONSIBILITY

All unsold new vehicles in dealer's possession and subject to this campaign must be held and inspected/repared per the service procedure of this campaign bulletin before owners take possession of these vehicles. Dealers are to service all vehicles subject to this campaign at no charge to owners, regardless of mileage, age of vehicle, or ownership, from this time forward.

Owners of vehicles recently sold from your new vehicle inventory for which the dealer receives the owner recall notification are to be contacted by the dealer, and arrangements made to make the required correction according to the instructions enclosed with this bulletin. This could be done by mailing to such owners a copy of the applicable owner letter accompanying this bulletin.

In Summary, whenever a vehicle subject to this campaign enters your vehicle inventory, or is in your dealership for service in the future, please take the steps necessary to be sure the campaign correction has been made before selling or releasing the vehicle.

In addition to a letter, owners will receive a recall notification/dealer claim form. The vehicle owner will present this form to you upon arrival for the service appointment. Please review the instructions on the face of the notification form and fill in the claim portion when the repair is completed.

Sincerely,



Chuck R. Zucker
Technical Coordinator Supervisor
Monaco Coach Corporation

Enclosures

crz/tt

Monaco Coach Corporation

Recall Repair Procedures

04V-080 5 of 11

Recall 04VXXXX Villa Seat Pedestal

1. Remove cap and loosen existing bolt to remove belt buckle.

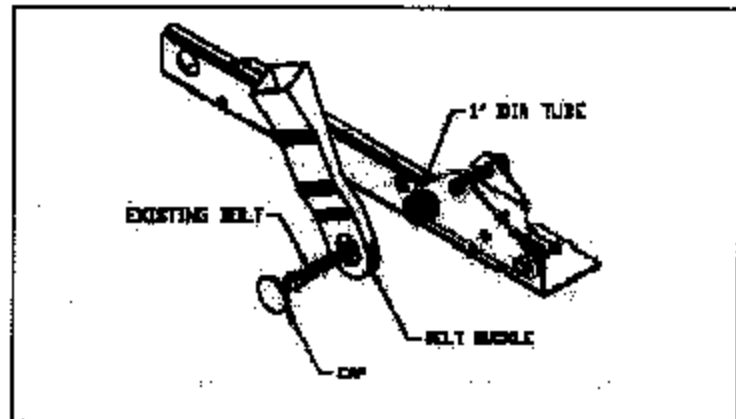

2. Insert 7/8 OD. X 3/8 ID. X 3/4 Spacer into 1" DIA. Tube.
3. Re-install belt buckle with 3/8 USS flat washer zinc & 3/8 - 16 X 2 grade 5 hex bolt.
4. Tighten bolt to 30 ft.lbs. & Replace cap

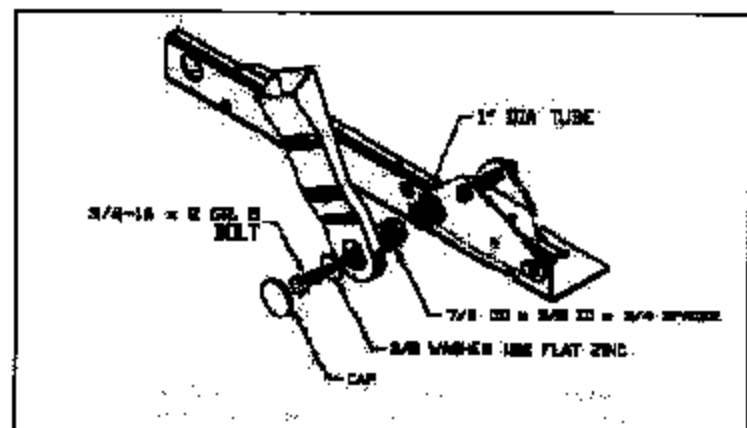

Parts: Kit # 04VXXXX-
Kit Contents:

04V-080 ⑥ of ⑩

Please fax the enclosed Recall Parts Purchase Order to 1-800-498-9478

Warranty Processing: Submit a warranty claim and recall notification form for each coach repaired, per instructions, using the Job Operation Code and time stated below.

Job Operation Code: xxxxxxxxxx Labor Allowance: 5 hr



MONACO COACH CORPORATION

RECALL PARTS PURCHASE ORDER

04VXXXXX

Villa Seat Pedestal

Monaco File R04001

Confirming Order Number: _____

Date: _____

Ship To: _____

Attention: _____

PO Number: _____

Parts: Order 1-Kit # **04VXXXXX** Per Unit Qty: _____

Kit Contents: 1 Bushing
1 Bolt

Customer Name:

Serial Number(s): _____

All parts will be shipped RPS ground unless other arrangements are made in advance.

FAX TO: 1-800-498-9478

MONACO COACH CORPORATION
P.O. Box 4313 • Elkhart, IN • 46514-0313
1809 W. Hively Ave • Elkhart, IN 46517



MONACO
COACH CORPORATION

February 16, 2004

VEHICLE SAFETY DEFECT SERVICE BULLETIN
Recall Campaign No. TBD
Monaco File # R04001

Re: Safety Recall – Villa International Seat Belt Buckle Mount

Dear Owner:

This notice is sent to you in accordance with the requirements of the National Traffic and Motor Vehicle Safety Act.

Monaco Coach Corporation has been notified by Villa International that certain 2004 Holiday Rambler Ambassador, Scepter, Imperial, and 2004 Monaco Windsor and Signature Class A motor homes fail to conform to Federal Motor Vehicle Safety Standards (FMVSS) No. 207/210 "Mounting of Driver and Passenger Seat Assembly", specifically the seat belt mounting to the seat frame. According to our information, your motor home identified on the enclosed form is affected. *Federal law requires that any vehicle lessor receiving this recall notice must forward a copy of this notice to the lessee within ten days.*

Villa International, manufacture of the seat and pedestal assembly, has made Monaco Coach aware that the seat belt buckle anchorage bolt could fail, potentially leading to the separation of the seat belt from the seat frame. This failure could result in unrestrained occupants in the Driver and/or the Passenger Seats during a crash impact which could lead to personal injury.

The remedy will involve the installation of a reinforcement bushing and grade 5 bolt to the seat belt anchorage system on both the driver and passenger seats.

If you had the seat belt anchoring bolt which is the subject of this letter remedied prior to receiving this letter, you may be eligible for reimbursement by Monaco Coach Corporation (Monaco) for your remedy costs.

You may contact your Monaco Coach Corporation dealer to arrange for a service appointment. Instructions for making this correction have been sent to your dealer and parts are readily available.

The labor time necessary to perform this recall campaign is approximately ½ hour. Please ask your dealer if you wish to know how much additional time may be needed to schedule and process your motor home.

The enclosed Recall Notification Form identifies your motor home and will serve as an authorization and claim form to have the correction made. Presentation of this form to your dealer will assist in making the necessary correction in the shortest possible time. If you have sold or traded your vehicle, or for any reason cannot have this recall service performed, please let us know by completing the postage paid reply card and returning it to us promptly.

Your Monaco Coach Corporation dealer is best equipped to provide service to ensure your motor home is corrected as promptly as possible. If, however, you take your motor home to your dealer on the agreed service date and the dealer does not remedy this condition on that date or within three (3) days, please call our toll free number of (800) 685-6545.

If, after contacting your dealer, and the recall assistance service line, you believe Monaco Coach Corporation has failed or has been unable to remedy the noncompliance without charge or there has been an unreasonable delay in securing the remedy, you may submit a complaint to the Administrator, National Highway Traffic Safety Administration, 400 Seventh Street, SW, Washington, DC 20590 or call the toll free Auto Safety Hotline at (888) 327-4236.

We apologize for this inconvenience. However, we have taken this action in the interest of your safety and continued satisfaction with your motor home.

Sincerely,



Chuck R. Zucker
Technical Coordinator Supervisor
Monaco Coach Corporation

crz/tt

National Highway Traffic Safety Administration
OFFICE OF DEFECTS INVESTIGATION
 400 7th Street, S.W. NSA-11
 Washington, DC 20590
 FAX #: (202) 366-7882

| | |
|-----------------------------------|--|
| To: Mr. Chuck R. Zucker | From: George H. Person, Chief ^{See 4V} _{CHP} |
| Company: Monaco Coach Corporation | Recall Management Division |
| FAX #: 574-389-4077 | Telephone: (202) 366-5210 |

EQ04-003

Safety Recall Follow-up Report

Date:

FEB 10 2004

The Office of Defects Investigation (ODI) is conducting a review of safety recall 03R-061, being performed by Villa International (Villa). This recall involves the integrated seat belt driver/passenger frame with model numbers 1170 or 1180 pedestal with 1" tube on seat belt buckle mount. The seat belt buckle anchorage can fail during Federal Motor Vehicle Safety Standard Nos. 207/210 testing.

According to information provided by Villa, Monaco Coach Corporation, (Monaco) was identified as a motor vehicle manufacturer who purchased and/or was supplied recalled seat belt buckle anchorage and should have been notified by Villa of the safety recall. The purpose of this request is to ascertain the disposition of the recalled seat belt buckle anchorages that were acquired by Monaco and identify any motor vehicle that may contain this equipment.

Under 49 U.S.C. § 30112(a), it is illegal for anyone, including a manufacturer, distributor, dealer, or retailer to sell an item of equipment or vehicle that fails to comply with all applicable Federal motor vehicle safety standards. "Noncompliance Information Reports," requires that a manufacturer provide the agency with a safety noncompliance information report within 5 days after deciding that a safety defect exists in its motor vehicles and item of equipment. Part 573.3(f) states that "In the case of a defect or noncompliance decided to exist in original equipment installed in the vehicles of more than one manufacturer, compliance with Part 573.5 is required of the equipment manufacturer as to the equipment item, and of each vehicle manufacturer as to the vehicles in which the equipment has been installed". Accordingly, Monaco may be required to file a Defect Report. As of this date, we have not received notification of the described defect from Monaco.

If Monaco does not agree with the decision made by Villa that the recalled seat belt buckle anchorages contain a safety defect and could have been installed in Monaco vehicles, then please provide an explanation for Monaco's position. If Monaco has not received any of these recalled seat belt buckle anchorages, please so state. If Monaco is not a vehicle manufacturer, please state the nature of its business and its relationship with Villa.

It is important that Monaco respond to this follow up report on time. A Safety Defect and Noncompliance Report Guide for vehicles is enclosed to assist you. Your failure to respond promptly and fully to this letter could subject Monaco to civil penalties pursuant to 49 U.S.C. § 30165 or lead to an action for injunctive relief.

Your response, in writing or by FAX, is to be submitted to this office by February 23, 2004, referencing BQ04-003. If you have any questions, please contact Mrs. Barbara E. Cooke at (202) 366-6098.

Enclosure