

3. Furnish the total number of vehicles recalled potentially containing the defect or non-compliance.

Model	2004	Total
Essex	83	83

4. Furnish the approximate percentage of the total number of vehicles estimated to actually contain the defect or noncompliance.

100 %, of the vehicles listed above, all eighty-three motor homes may contain the defect.

5. Describe the defect or non-compliance. The description should address the nature and physical location of the defect or non-compliance. Illustrations should be provided as appropriate.

The seat belt latch where bolted on the seat frame may fail in the unlikely event of an accident.

Describe the cause of the defect or noncompliance condition.

Due to a hollow space in the location of the buckle attachment, the bolt may not be supported and may shear.

Describe the consequence(s) of the defect or noncompliance condition.

In a forward impact crash, the belt bolt could shear allowing the driver/passenger to potentially risk serious injury or death.

Describe any warning which can (a) precede or (b) occur.

None.

If the defect or noncompliance is in a component or assembly purchased from a supplier, identify the supplier by corporate name and address:

Villa International
502 E. Julianna Street,
Anaheim, CA 92801

Robert Long
Vice President of Sales
(714) 535-7272

6. If defect, furnish a chronological summary with dates of all the principle events that were the basis for the determination of the defect. Include number of reports, accidents, injuries, fatalities, and warranty claims.

Please refer to information provided in Villa International's 573 Defect and Noncompliance Report.

7. If noncompliance, identify and provide the test results or other data in chronological order with dates on which the noncompliance was determined.

n/a

8. Furnish a description of the manufacturer's remedy for the defect or noncompliance. Clearly describe the differences between the recall condition and the remedy.

Check belt latch bolt and install a bushing for support. Please refer to Villa International's 573 Defect and Noncompliance Report attached.

Clearly describe the distinguishing characteristics of the remedy component/ assembly versus the recalled component/ assembly.

A bushing will be installed along with the grade 5 bolt.

Identify and describe how and when the recall condition was corrected in production. If the production remedy was identical to the recall remedy in the field, so state. If the product was discontinued, so state.

Production process was changed on November 25, 2003, at Villa and at Newmar. Please refer to Villa International's 573 Defect and Noncompliance Report.

Furnish a recall schedule or agenda, with specific dates, for notification to other manufacturers, dealers/retailers, and purchasers. Please identify any foreseeable problems with implementing this recall.

Estimated notification schedule: 3/5/04- Notification letter Dealers; 5/7/04- Notification letter to owners.

9. Furnish a final copy of all notices, bulletins, and other communications that relate directly to the defect or noncompliance and which are sent to more than one manufacturer, distributor, or purchaser. This includes all communications concerning this recall.

Responsibility of Villa International.

The manufacturer's campaign identification number if not identical to the number assigned by NHTSA.

Newmar's identification number will be assigned by NHTSA.

All Documents To Be Faxed To (202) 366-7882, Then Mailed.

**TO:****FROM:****DATE:****SUBJECT: Campaign # 03E-061**

This notice is sent to you in accordance with the requirements of the National Traffic and Motor Vehicle Safety Act. Newmar Corporation has been advised by Villa International (Driver/ Passenger seating supplier) that a defect has been determined, which relates to motor vehicle safety, and exists in **2004 Essex Class A Motor Homes built between April 20, 2003 and November 26, 2003**. The National Traffic and Motor Vehicle Safety Act, as amended, provides that each vehicle which is subject to a recall campaign of this type must be satisfactorily repaired within a reasonable time after the owner has tendered it for repair. A failure to adequately repair within 60 days after tender of a vehicle is prima facie evidence of failure to repair within a reasonable time.

If the condition is not properly repaired within a reasonable time, the owners may be entitled to an identical or reasonably equivalent vehicle at no charge or to a refund of the purchase price less a reasonable allowance for depreciation.

To avoid having to provide these troublesome solutions, every effort must be made to promptly schedule an appointment with each owner and to repair their vehicle as soon as possible. As you will see in reading the enclosed copy of the letter which is being sent to owners, the owners are being instructed to contact Newmar Corporation if you do not remedy the condition within five days of the mutually agreed upon service date. If the condition is not remedied within a reasonable time, they are instructed on how to contact the National Highway Traffic Safety Administration.

REASON FOR THIS CAMPAIGN

Villa International has informed Newmar of an anchorage bolt for the Driver/ Passenger seat that could fail in the unlikely event of an accident, potentially leading to serious injury or death to the occupant.

OWNER NOTIFICATION**(CONSUMER AFFAIRS)**

DEALER CAMPAIGN RESPONSIBILITY

Dealers are to provide to all customer/owner vehicles the service of completing this campaign at no charge to the customer/owner regardless of vehicle age, vehicle mileage, or ownership at the time of repair.

REPAIR PROCEDURE (See print with instructions provided)

- STEP 1. Locate and remove bolt from aisle side seat belt buckle.
- STEP 2. Insert 7/8 OD x 3/8 ID x 3/4 spacer into 1" diameter tube.
- STEP 3. Re-install belt buckle with 3/8 USS flat washer zinc & 3/8-16 x 2, grade 5 hex bolt.
- STEP 4. Tighten bolt to 30 ft. lbs.

AFFECTED MODELS

2004 Essex Class A Motor Homes built between April 20, 2003 and November 26, 2003

PARTS INFORMATION

<u>QTY</u>	<u>PART #</u>	<u>DESCRIPTION</u>
1		Package contains bolt and bushing

REIMBURSEMENT**(CONSUMER AFFAIRS)**

<u>FLAT RATE CODE</u>	<u>DESCRIPTION</u>	<u>TIME ALLOWED</u>

Thank you for your cooperation.
Sincerely,

Newmar Corporation



Date

Dear Newmar Owner:

SUBJECT: Newmar Serial #, Chassis Serial #, and Campaign #03E-061

This notice is sent to you in accordance with the requirements of the National Traffic and Motor Vehicle Safety Act. Newmar Corporation has been advised by Villa International (Driver/ Passenger seating supplier) that a defect has been determined, which relates to motor vehicle safety, and exists in certain **2004 Essex Class A Motor Homes built between April 20, 2003 and November 26, 2003**. Our records indicate that you have purchased this vehicle.

REASON FOR THIS CAMPAIGN

Villa International has informed Newmar of an anchorage bolt for the Driver/ Passenger seat that could fail in the unlikely event of an accident, potentially leading to serious injury or death to the occupant.

WHAT WE WILL DO

Newmar will remedy this defect by inserting a reinforcement bushing and verifying a grade 5 bolt is used. This will be performed with no charge.

WHAT YOU SHOULD DO

Because this defect affects motor vehicle safety, it is recommended that you contact the Newmar service department immediately at (800) 731-8300. An associate will assist you in making an appointment to have this repair done by an authorized Newmar Dealer or Service Center.

Newmar dealers are best equipped to obtain parts and provide service to ensure your vehicle is corrected as promptly as possible. HOWEVER, if you take your vehicle to the dealer on the agreed date and the dealer does not service this condition on that date or within five days, we recommend you contact the Newmar Corporation Consumer Affairs Department at 1-800-731-8300.

If you believe Newmar Corporation has failed to remedy the defect without charge to you or within a reasonable period of time, you may submit a complaint to:

Administration
National Highway Traffic Safety Administration
400 Seventh Street, SW
Washington, DC 20590
1-888-327-4236

If you no longer own this vehicle, please furnish us the complete name and address of the person or dealership you sold or traded your vehicle to. Thank you for your cooperation.

Sincerely,

Newmar Corporation

Enclosure

NEWMAR SERIAL NUMBER: _____

VIN NUMBER: _____

DATE THAT YOU RECEIVED THIS NOTICE: _____

DATE SET FOR REPAIR OF YOUR MOTORHOME: _____

DATE REPAIR COMPLETED: _____

**NAME OF SERVICE CENTER REPAIR
WAS COMPLETED AT:** _____

SERVICE CENTER ADDRESS: _____

CUSTOMER SIGNATURE: _____

**PLEASE MAIL A COPY OF THIS TO NEWMAR CORPORATION AT THE
COMPLETION OF THIS REPAIR.**

**NEWMAR CORPORATION
355 N. DELAWARE STREET
PO BOX 30
NAPPANEE, IN 46550-0030**

ALL INFORMATION CONTAINED HEREIN IS UNCLASSIFIED EXCEPT WHERE SHOWN OTHERWISE BY THE NATIONAL ARCHIVES AND IS RELEASED IN FULL TO THE PUBLIC.

REV.	DATE	BY	APP'D.

CO-PILOT

PILOT

NEWMAR



* BELT BUCKLE *

**TOOLS REQUIRED:**

- TORQUE WRENCH
- 9/16 SOCKET

INSTRUCTIONS TO REPLACE BELT BUCKLE HARDWARE:

1. LOCATE BELT BUCKLE, I.E., AISLE SIDE OF THE VEHICLE. SEE ABOVE FIGURES. BELT BUCKLE LOCATION INDICATED BY AN ASTERISK (*).
2. TAKE OUT THE CAP AND LOOSEN EXISTING BOLT TO REMOVE BELT BUCKLE. SEE FIG. 1.
3. INSERT 7/8 ID x 3/8 ID x 3/4 SPACER INTO 1" DIA. TUBE. SEE FIG. 2.
4. RE-INSTALL BELT BUCKLE WITH 3/8 USS FLAT WASHER ZINC & 3/8-16 x 2 GRADE 5 HEX BOLT. SEE FIG. 2.
5. TIGHTEN BOLT TO 30 FT. LBS. PUT CAP BACK ON.

NOTES UNLESS OTHERWISE SPECIFIED:

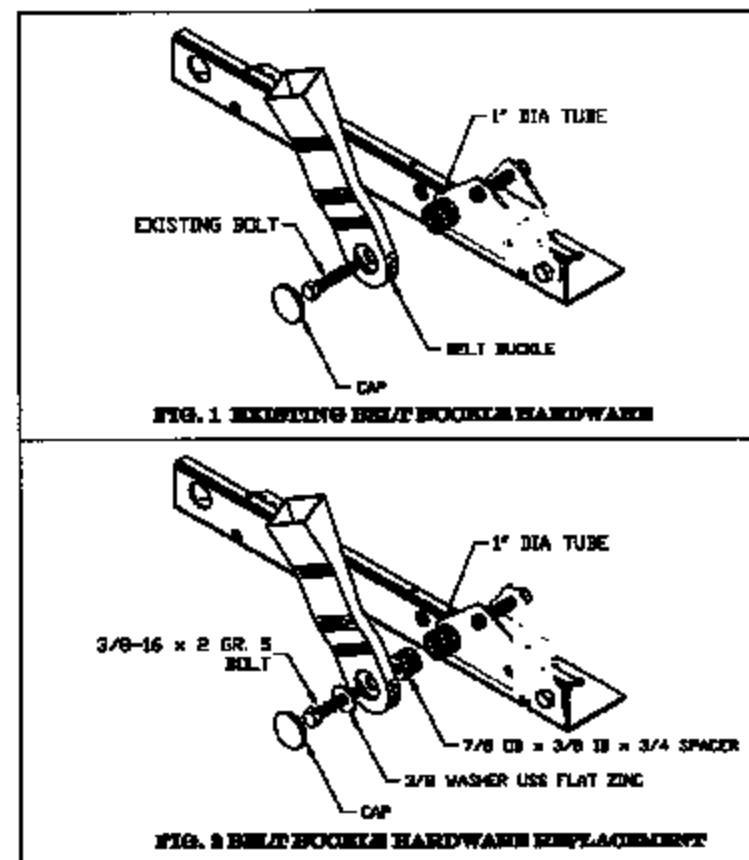

INCHES

UNLESS OTHERWISE SPECIFIED

DRAWN BY

CHK'D BY

DATE

SCALE

SHEET

APPROVED BY

DATE

DRAWN BY

CHK'D BY

DATE

SCALE

SHEET

VILLA

P.O. BOX 10000

INDIANAPOLIS, IN 46206

TELEPHONE (317) 552-9978

FAX (317) 552-9978

PART NO. 04V-056

REV. 1/94

SCALE 1:1 (SEE FIG. 04V-056)

SHEET 1 OF 1

REPLACES 04V-056

REPLACES 04V-056

REPLACES 04V-056

REPLACES 04V-056

REPLACES 04V-056

REPLACES 04V-056

REPLACES 04V-056