

Ford Motor Company

RECEIVED
NVS-215

2003 SEP 17 A 11:09

OFFICE OF
DEFECTS INVESTIGATION

James P. Vondale, Director
Automotive Safety Office
Environmental & Safety Engineering

September 15, 2003

Mr. George Person, Chief
Recall Management Division (NVS-215)
Office of Defects Investigation
National Highway Traffic Safety Administration
400 Seventh Street, S.W.
Washington, DC 20590

Dear Mr. Person:

**Subject: Safety Recall 03V-282
(Ford Number 03S06)**

Pursuant to the requirements set forth in Part 573 of Title 49 of the Code of Federal Regulations – Defect and Noncompliance Reports, Ford Motor Company is submitting a true or representative copy of information that relates directly to the subject campaign.

Attached are dealer and owner letters issued by Ford Customer Service Division regarding a recall of certain 2001 through 2003 model year Econoline 5.4L Cutaway Chassis Cabs built with School Bus Option. Specific details were submitted to you in a letter dated August 4, 2003. Owner notification letters were mailed on September 3, 2003.

Sincerely,



J. P. Vondale

Attachment(s)
03S06 Dealer-Owner Bulletin





Frank M. Ligon
Director
Service Engineering Operations
Ford Customer Service Division

Ford Motor Company
P. O. Box 1804
Dearborn, Michigan 48121

August 2003

TO: All U.S. Ford and Lincoln Mercury Dealers

SUBJECT: DEMONSTRATION / DELIVERY HOLD - Safety Recall 03S06:
Certain 2001 - 2003 Econoline 5.4L Cutaway Chassis Cabs Built with School
Bus Option - Rear Crossmember / Side Reinforcement Inspection

AFFECTED VEHICLES

Certain 2001 - 2003 model year Econoline 5.4L Cutaway Chassis Cabs equipped with the school bus option, built at the Lorain Assembly Plant from June 18, 2001 through March 20, 2003. A total of sixty-four units are affected nationwide.

REASON FOR THIS SAFETY RECALL

In some of the affected vehicles, the rear crossmember and side reinforcement brackets and bolts may not have been installed. These components are only present on gasoline engine equipped E-Series Cutaway Chassis. In the event of an accident, the gasoline fuel tank may not be properly protected, which could result in a fuel leak. A fuel leak in the presence of an ignition source could result in a fire.

SERVICE ACTION

Ford is conducting a voluntary safety recall to inspect, and if necessary, add two missing crossmember brackets and two side reinforcement brackets in the area of the fuel tank. A majority of the sixty-four (64) affected vehicles involved in this concern were sold to service fleets, but some are still in transit or at body builder locations. Since many of these vehicles are not readily available to dealers, Ford Motor Company has contracted the services of Engineering Analysis Associates, Inc. (EAA). They will locate the affected vehicles, inspect for the presence of the crossmember and reinforcement bracket assemblies and, if necessary, install the missing components.

If any of the affected vehicles are in your dealer stock, we are asking you to contact EAA at 1-800-821-3036 to arrange a time for inspection; if desired, you can inspect for the presence of the rear crossmember and two side reinforcements before contacting EAA (See Attachment II). For vehicles that have been delivered to customers, contact EAA and provide them the name, address and phone number of the customer. EAA will coordinate the inspection and/or repair.

PLEASE NOTE

Correct all vehicles in stock before delivery by inspecting or calling EAA. Federal law requires dealers to complete any outstanding safety recall service before a new vehicle is delivered to the buyer or lessee. Violation of this requirement by a dealer could result in a civil penalty of up to \$5,000 per vehicle.

ATTACHMENTS

- Attachment I: Administrative Information
- Attachment II: Labor Allowances and Parts Ordering Information
- Attachment III: Technical Information
- Customer Notification Letter

QUESTIONS?

- Claims Information: 1-800-423-8851
- Field Service Action (FSA) VIN Lists Support: 1-800-555-9801
- Special Service Support Center (Dealer Only) Questions: 1-800-325-5821
- Engineering Analysis Associates, Inc..... 1-800-821-3036

Sincerely,

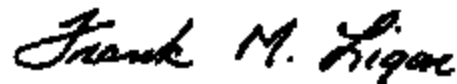

Frank M. Ligon

Safety Recall 03S06
Certain 2001 - 2003 Econoline 5.4L Cutaway Chassis Cabs Built with School Bus Option
Rear Crossmember / Side Reinforcement Inspection

OASIS

You must use OASIS to determine if a vehicle is eligible for this recall. If you find any of the affected vehicles in your dealer stock, we are asking you to contact EAA at 1-800-821-3036 to arrange a time for inspection; if desired, you can inspect for the presence of the rear crossmember and two side reinforcements before contacting EAA (See Attachment II).

CLAIMS PREPARATION AND SUBMISSION

- Enter claims for inspection using DWE.
- Refer to ACESII manual for claims preparation and submission information.

OWNER REFUNDS

Ford Motor Company is offering a refund for owner-paid repairs covered by this Safety Recall if the repair was performed prior to the date indicated in the reimbursement plan, which is posted with this bulletin. This plan is also available to owners through the Customer Relationship Center (CRC). The CRC will direct owners to seek reimbursement through authorized dealers or, at their option, directly through Ford Motor Company at P.O. Box 1904, Dearborn, MI 48121.

Dealers are also authorized to refund owner-paid emergency repairs that were performed away from an authorized servicing dealer.

Refund Claiming Information

Program Code:	03S06
Misc. Expense:	REFUND
Misc. Expense:	ADMIN
Misc. Expense:	0.2 Hrs.

RENTAL CARS

The use of rental vehicles is not authorized for this program.

Safety Recall 03S08

Certain 2001 - 2003 Econoline 5.4L Cutaway Chassis Cabs Built with School Bus Option
Rear Crossmember / Side Reinforcement Inspection

LABOR ALLOWANCES

Description	Labor Operation	Labor Time
Inspect for Crossmember and reinforcement brackets; contact EAA	03S08A	0.2 Hours

SPECIAL NOTE

Dealers may inspect vehicles for the crossmember and side reinforcements. If none of these parts are missing, please call EAA at 1-800-821-3036 to update their records and prevent an unnecessary customer contact. If any of these parts are missing, contact EAA at 1-800-821-3036 to arrange for the parts to be installed. It is estimated that approximately 20% of the sixty-four (64) involved Econolines will require this repair.

PARTS REQUIREMENTS

Dealers are not required to obtain parts for these vehicles.

**CERTAIN 2001-2003 E-SERIES 5.4L CUTAWAY CHASSIS CAB WITH
SCHOOL BUS OPTION —
REAR CROSSMEMBER/SIDE REINFORCEMENT INSPECTION**

OVERVIEW

This program involves inspecting the vehicle for the presence of a rear crossmember (located behind the rear fuel tank support) and side reinforcements (located outside the frame rails adjacent to the rear crossmember).

INSPECTION

From behind the rear wheels, look up under the vehicle body and inspect for the side reinforcements and crossmember. All three (3) pieces must be present. See Figure 1.

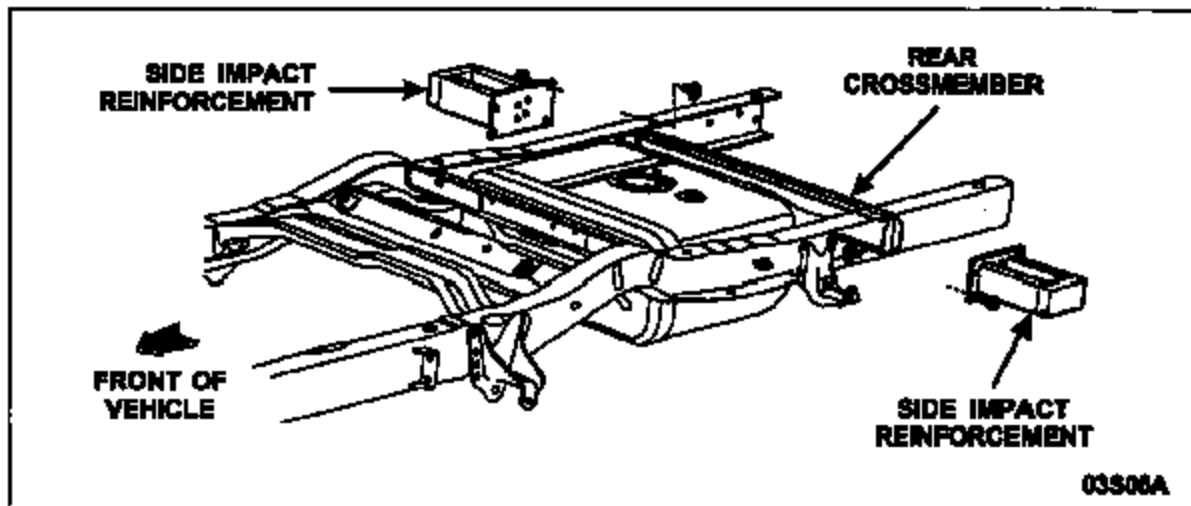

FIGURE 1

- If the components are installed, no further service is required. Note on the repair order "PARTS ARE PRESENTLY INSTALLED ON THE VEHICLE" and release the vehicle. Submit claim for inspection (See Attachment II).
- If the components are NOT installed, advise your service manager. Engineering Analysis Associates (EAA) must be contacted at 1-800-821-3036 to arrange additional service (see Attachment II).





Frank M. Ligon
Ford Motor Company
P. O. Box 1904
Dearborn, Michigan 48121

August 2003

Safety Recall 03S06

Mr. John Sample
123 Main Street
Anywhere, USA 12345

Your Vehicle Identification Number: 12345678901234567

This notice is sent to you in accordance with the requirements of the National Traffic and Motor Vehicle Safety Act.

Ford Motor Company has decided that a defect which relates to motor vehicle safety exists in certain 2001 to 2003 model year Econoline 5.4L Cutaway Chassis Cabs built with the school bus option.

We apologize for this situation and want to assure you that, with your assistance, we will correct this condition. Our commitment, together with Ford and Lincoln Mercury dealers, is to provide you with the highest level of service and support possible.

What is the issue?

In some of the affected vehicles, the rear crossmember, reinforcement brackets and bolts may not have been installed. In the event of an accident, the gasoline fuel tank may not be properly protected, which could result in a fuel leak. A fuel leak in the presence of an ignition source could result in a fire.

What will Ford Motor Company do?

In an effort to service these vehicles in a timely manner, Ford Motor Company has contracted the services of Engineering Analysis Associates, Inc. (EAA). An EAA representative will contact you, inspect for the presence of the crossmember and reinforcement bracket assemblies and, if missing, install these components on your vehicle.

How long will it take?

The time needed for this repair is less than one-half day.

What we asking you to do?

If you have not already been contacted, you may contact EAA at 1-800-821-3036 to schedule an appointment. When the EAA associate arrives at your location, we ask that you allow him or her to inspect your vehicle and, if necessary, install the missing components.

Please note: Federal law requires that any vehicle lessor receiving this recall notice must forward a copy of this notice to the lessee within ten days.

Have you previously paid for this repair?

If you paid to remedy the issue addressed in this notice, you may be eligible for a refund either through your dealer or directly from Ford Motor Company. You may also be eligible for a refund if you had this service performed as an emergency repair away from an authorized servicing dealer.

To verify eligibility and expedite reimbursement, give your paid original receipt to your dealer.

Refund requests, including all required documentation, may also be mailed to Ford at P.O. Box 1904, Dearborn, Michigan 48121. Refund requests mailed to Ford may take up to 60 days to process.

Detailed information regarding eligibility for Ford's reimbursement program may be obtained by contacting the Ford Customer Relationship Center at 1-866-436-7332..

Have you changed your address or sold the vehicle?

Please fill out the enclosed prepaid postcard and mail it to us so we can update our records. If you have sold the vehicle, the information you provide on the postcard will be used to notify the new owner about this safety recall.

Can we assist you further?

If you have trouble getting your vehicle repaired promptly and without charge, please contact the Ford Motor Company Customer Relationship Center and one of our representatives will be happy to assist you:

Call (866) 438-7332

Office Hours (Eastern Time Zone)

Monday through Friday: 8AM – 11PM

Saturday: 8AM – 6PM

Hearing impaired call (800) 232-5952 TDD for the hearing impaired.

www.ownerconnection.com

If you are still having trouble getting your vehicle repaired in a reasonable time or without charge, you may write the Administrator, National Highway Traffic Safety Administration, 400 Seventh Street S. W., Washington, D. C. 20590 or call the toll free Auto Safety Hotline at 1-888-327-4236 or 1-800-424-9393.

Thank you for your attention to this important matter.

Sincerely,

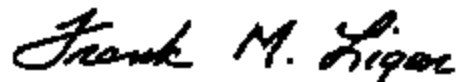

Frank M. Ligon
Director
Service Engineering Operations