

[2022 Chevrolet Silverado 1500 - 4WD New \(RPO J22, VIN Digit 5 = D\)](#) |

[Cheyenne New, Silverado 1500 New Service Manual 15539872](#) | [Engine/Propulsion](#) | [Engine Mechanical - 5.3L L84, 6.2L L87](#) |

[Repair Instructions](#) | **Document ID:** [REDACTED]

Engine Removal and Installation (L87 without ZR2)

Single Use Fasteners and Components

- Accessory Drive Auxiliary Belt
- Accessory Drive Primary Belt
- Air Conditioning Compressor and Condenser Hose Seal [2x]
- Engine Mount Frame Side Bolt [3x]
- Engine Oil Cooler Gasket
- Engine Oil Cooler Retainer [2x]
- Exhaust System Seal [2x]
- Intake Manifold Gasket [8x]
- Oil Filter
- Water Pump Gasket [2x]

Special Tools

Engine Heating and Cooling

GE-47716 Vac-N-Fill Coolant Refill Tool

Equivalent regional tools: [Special Tools](#)

Engine Mechanical - 5.3L (L84) or 6.2L (L87)

- DT-21366 Converter Holding Strap
- EN-36857 Engine Lift Bracket
- EN-51767 Stretchy Belt Installer
- EN-52059 Engine Support Fixture Adapter Bolt - M10

Equivalent regional tools: [Special Tools](#)

Removal Procedure

1. Recover the refrigerant. [Refrigerant Recovery and Recharging](#).
2. Relieve the fuel system pressure. [Fuel Pressure Relief](#)
3. Disconnect the battery negative cable. [Battery Negative Cable Disconnection and Connection](#)

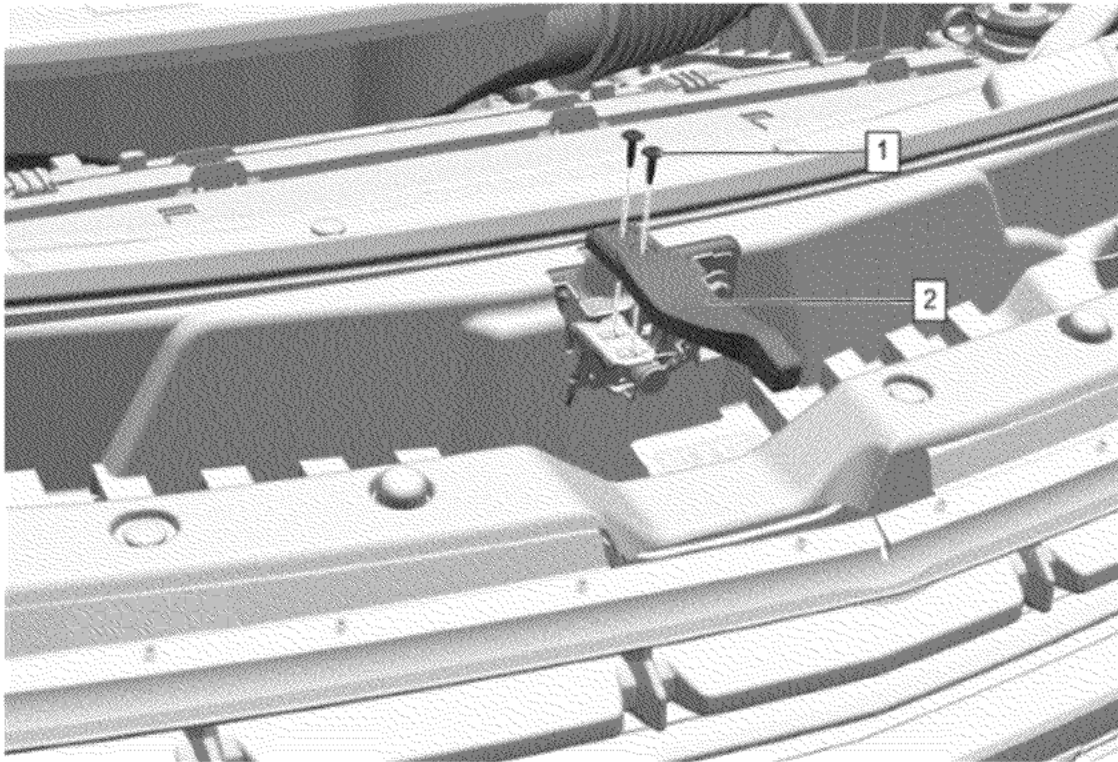

- 4. Hood Latch Actuator Bolt (1) » Remove [2x]
- 5. Hood Secondary Latch Release Handle (2) » Remove

© 2025 General Motors. All rights reserved.

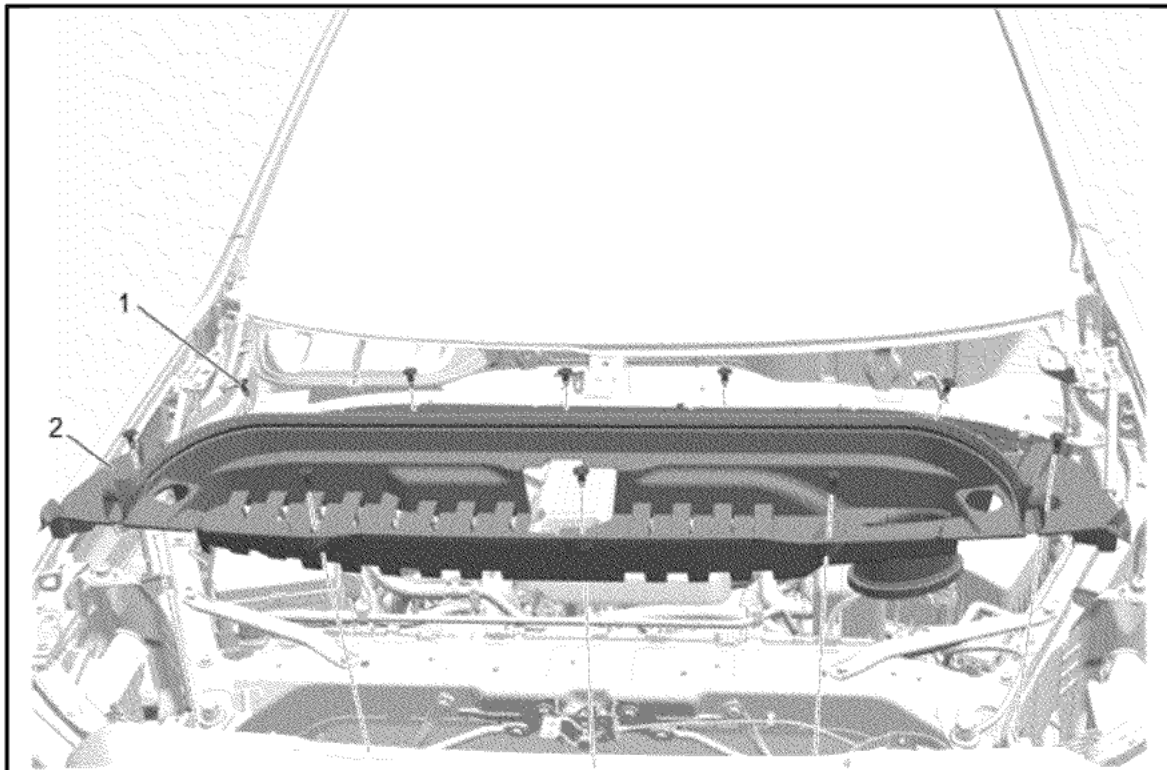

6. Intake Air Baffle Retainer (1) » Remove [10x]
7. Intake Air Splash Shield (2) » Remove
8. Front Wheelhouse Liner - Left Side and Right Side » Remove [2x] — Front Wheelhouse Liner Replacement

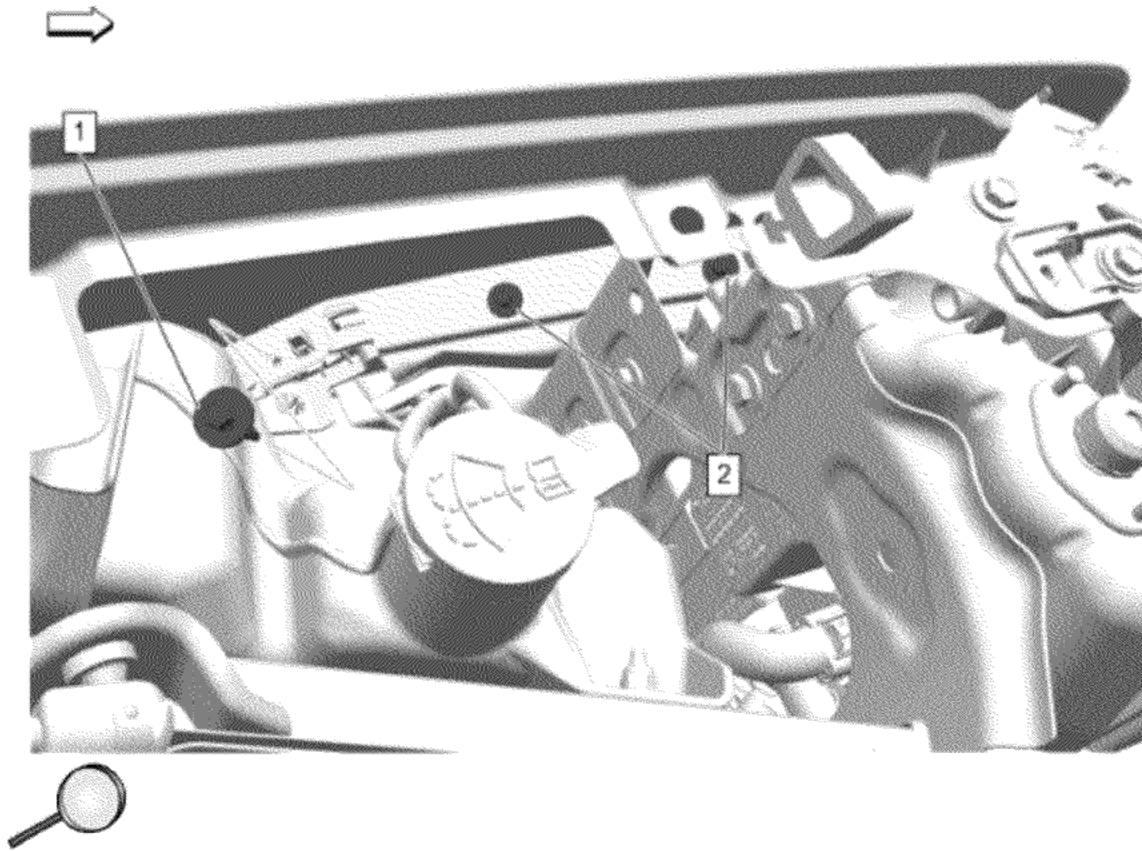

© 2025 General Motors. All rights reserved.

Note: Left side shown, right side similar.

9. Front Bumper Fascia Guide Bolt - Left Side and Right Side (1) » Loosen [2x]
10. Front Bumper Fascia Guide Bolt - Left Side and Right Side (2) » Loosen [4x]

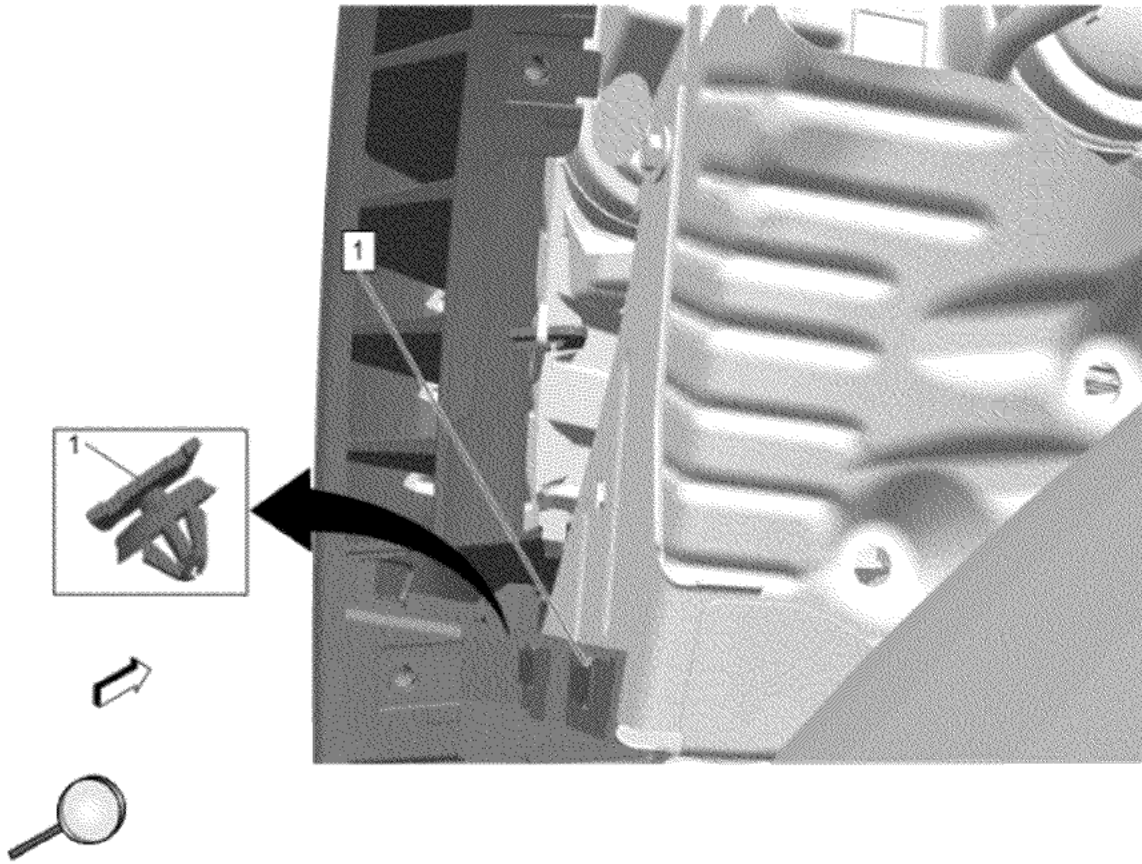

Note: Left side shown, right side similar.

11. Front Bumper Fascia Reinforcement Retainer - Left Side and Right Side (1) » Release [4x]

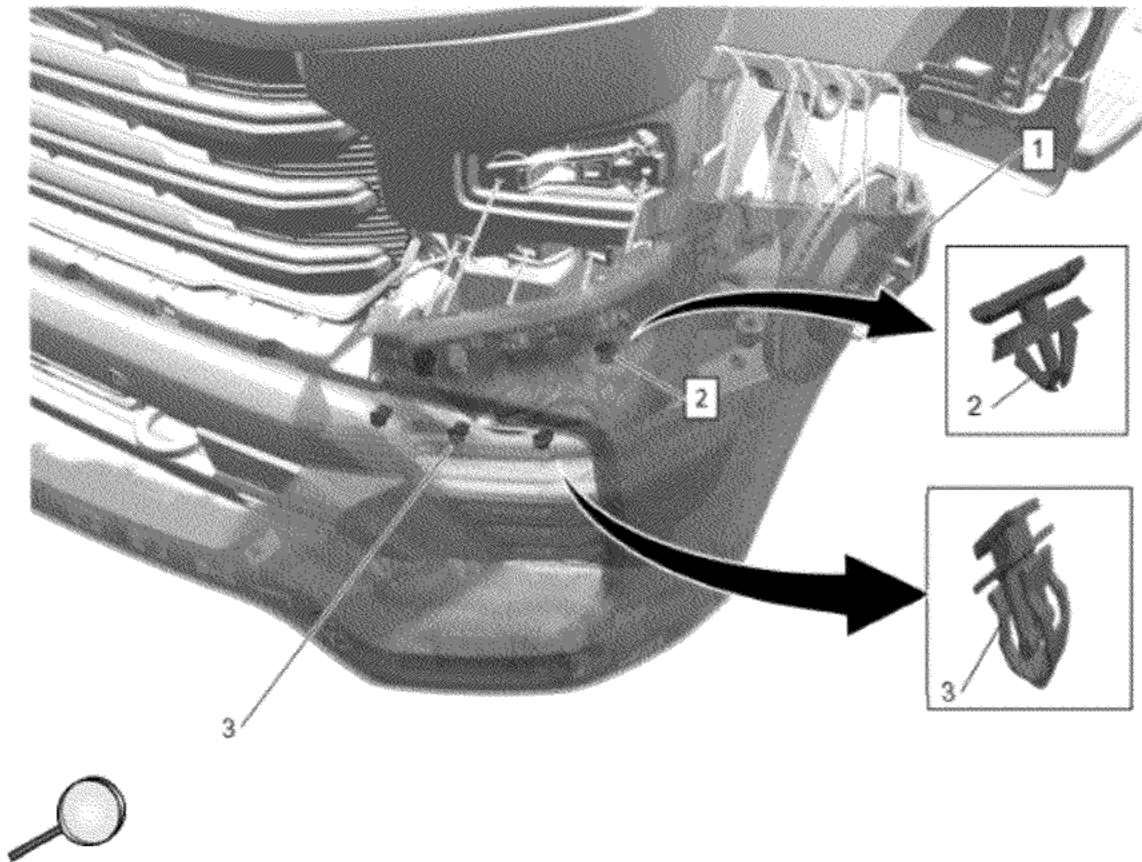

Note: Left side shown, right side similar.

12. Apply a double layer of masking tape around the perimeter of the painted surfaces and headlamps.
13. Carefully push a small nylon wedge between the left side and right side front bumper upper fascia (1) and the fascia guide. Insert a small flat-bladed tool into the front bumper upper fascia slot and depress the snaps one at a time and pull on the fascia at the same time to gradually remove the fascia.
14. Front Bumper Fascia Retainer - Left Side and Right Side (2) » Release [4x]
15. Front Bumper Fascia Reinforcement Retainer - Left Side and Right Side (3) » Release [6x]

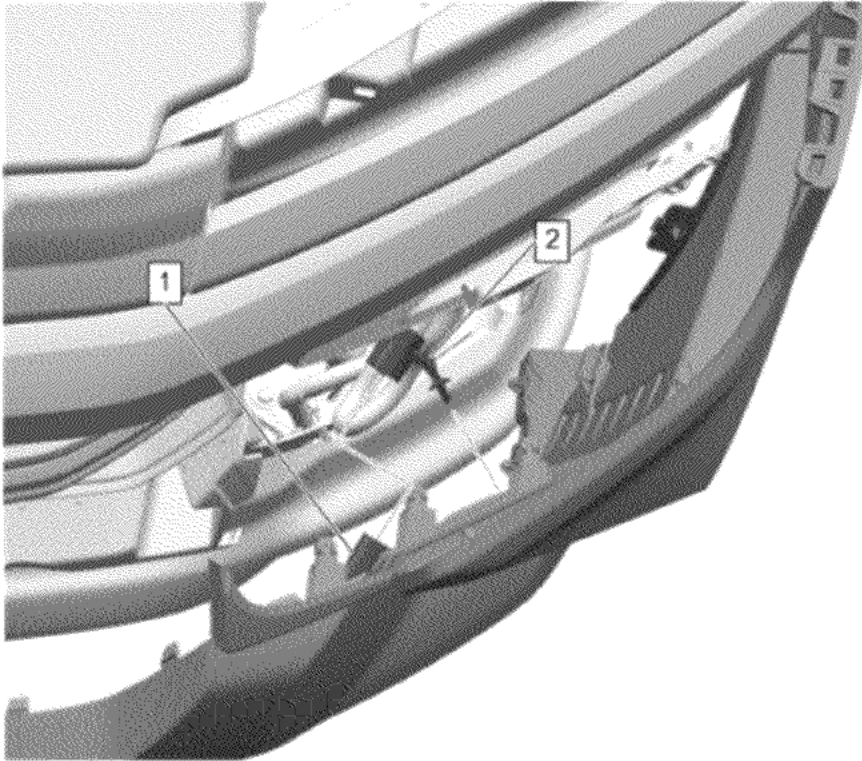

© 2025 General Motors. All rights reserved.

Note: Left side shown, right side similar.

16. { If equipped } Wiring Harness Retainer - Left Side and Right Side (2) » Release [2x]
17. { If equipped } Electrical Connector - Left Side and Right Side (1) » Disconnect [2x]

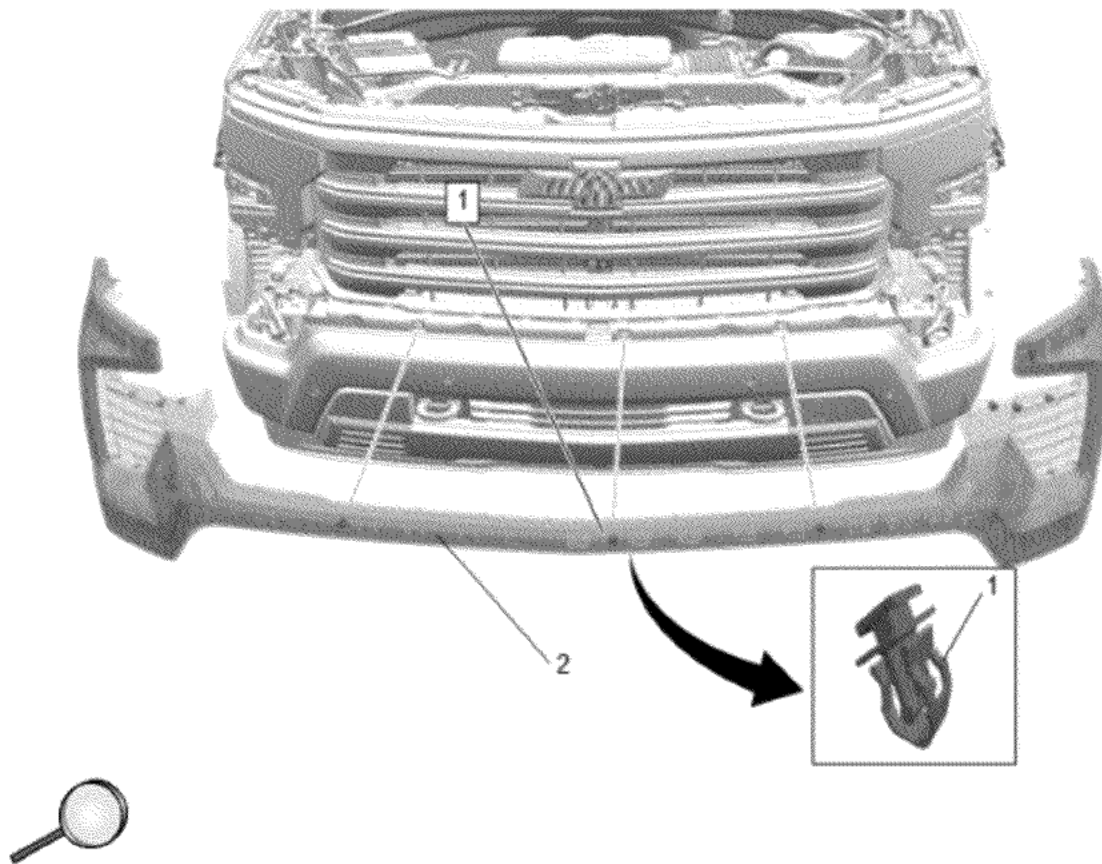

18. Using a trim type tool, release the 3 front bumper fascia reinforcement retainer (1) and release the tabs.
19. With the aid of an assistant, remove the fascia. (2)

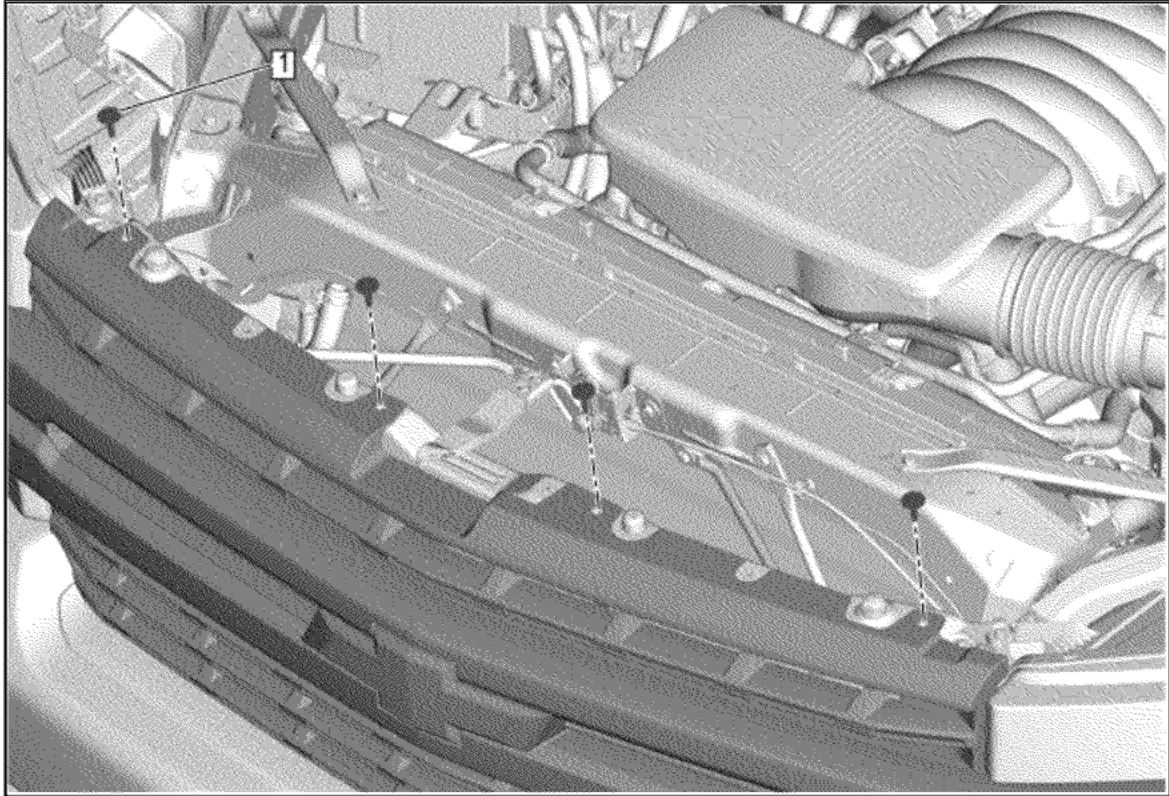

20. Front Grille Bolt (1) » Remove [4x]

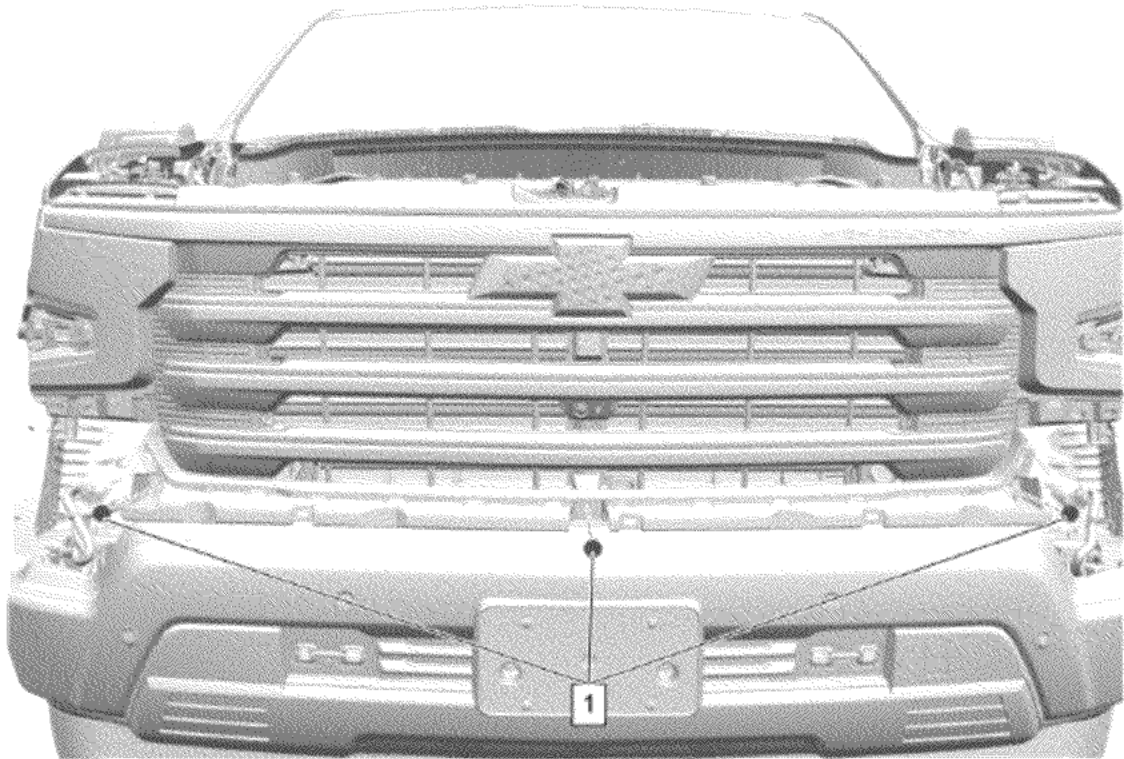

21. Front Grille Bolt (1) » Remove [3x]

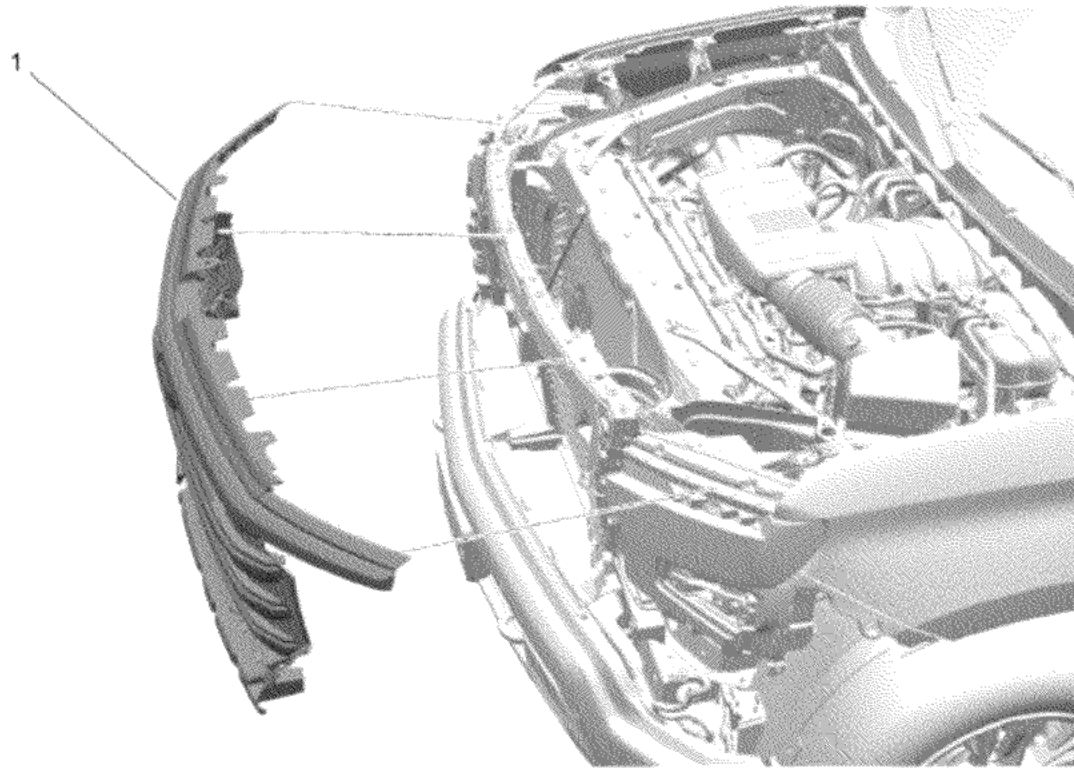

22. { If equipped } Disconnect the electrical connector.
23. { If equipped } Front View Driver Information Camera Nozzle Hose » Disconnect
24. Front Grille (1) » Remove
25. Remove underbody panels as necessary. [Underbody Panel Component Locator](#)

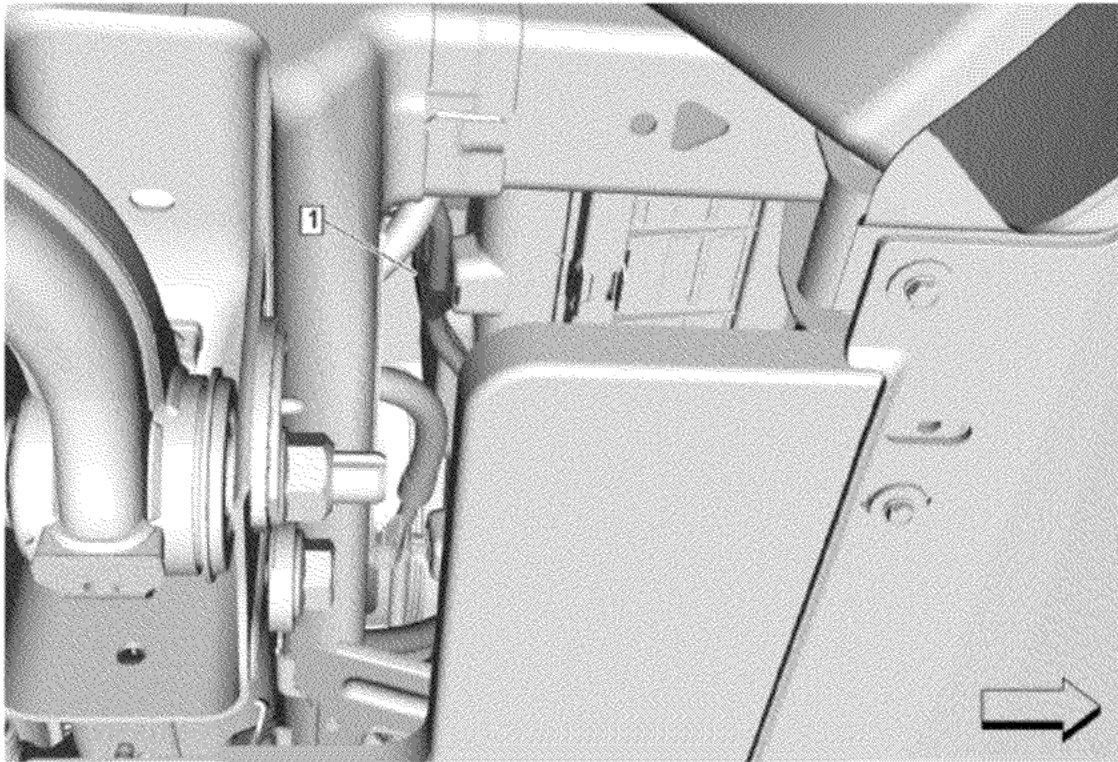

26. Engine Oil Cooler Hose Clip (1) » Release
27. Drain the coolant. [Cooling System Draining and Filling](#)
28. Drain the engine oil. [Engine Oil and Oil Filter Replacement](#)

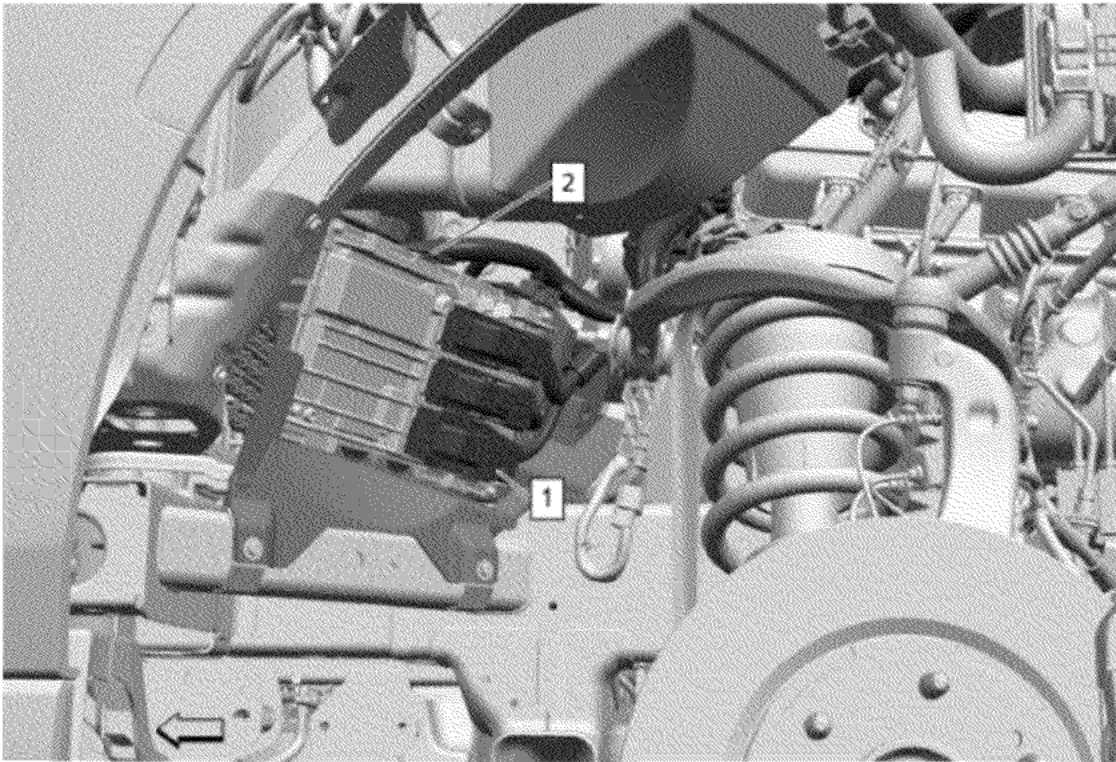

Warning: Refer to [Safety Glasses Warning](#).

Caution: Always turn the ignition off when installing or removing the ECM connectors in order to prevent damage to the components.

Caution:

- Turn the ignition OFF when installing or removing the control module connectors and disconnecting or reconnecting the power to the control module (battery cable, powertrain control module (PCM)/engine control module (ECM)/transaxle control module (TCM) pigtail, control module fuse, jumper cables, etc.) in order to prevent internal control module damage.
- Control module damage may result when the metal case contacts battery voltage. DO NOT contact the control module metal case with battery voltage when servicing a control module, using battery booster cables, or when charging the vehicle battery.
- In order to prevent any possible electrostatic discharge damage to the control module, do not touch the connector pins or the soldered components on the circuit board.
- Remove any debris from around the control module connector surfaces before servicing the control module. Inspect the control module connector gaskets when diagnosing or replacing the control module. Ensure that the gaskets are installed correctly. The gaskets prevent contaminant intrusion into the control module.
- The replacement control module must be programmed.

29. Disconnect the electrical connectors. (1)

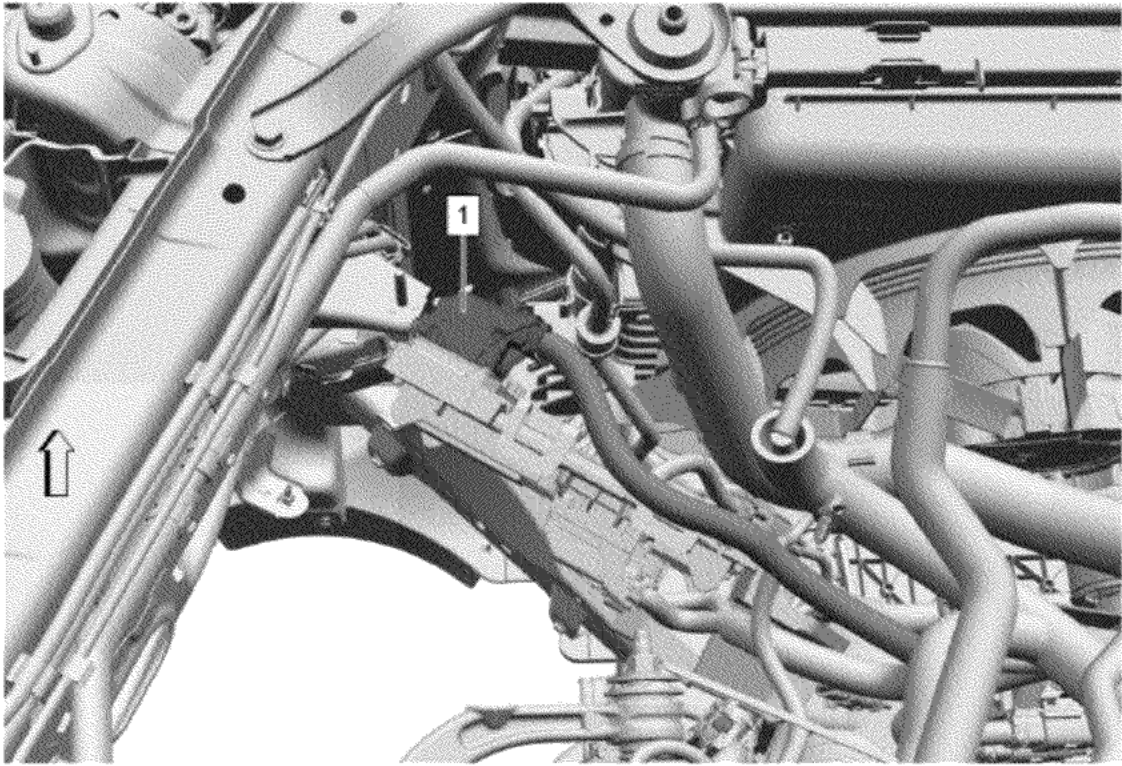

Note: Parts removed from graphic for clarity.
30. Disconnect the electrical connector. (1)

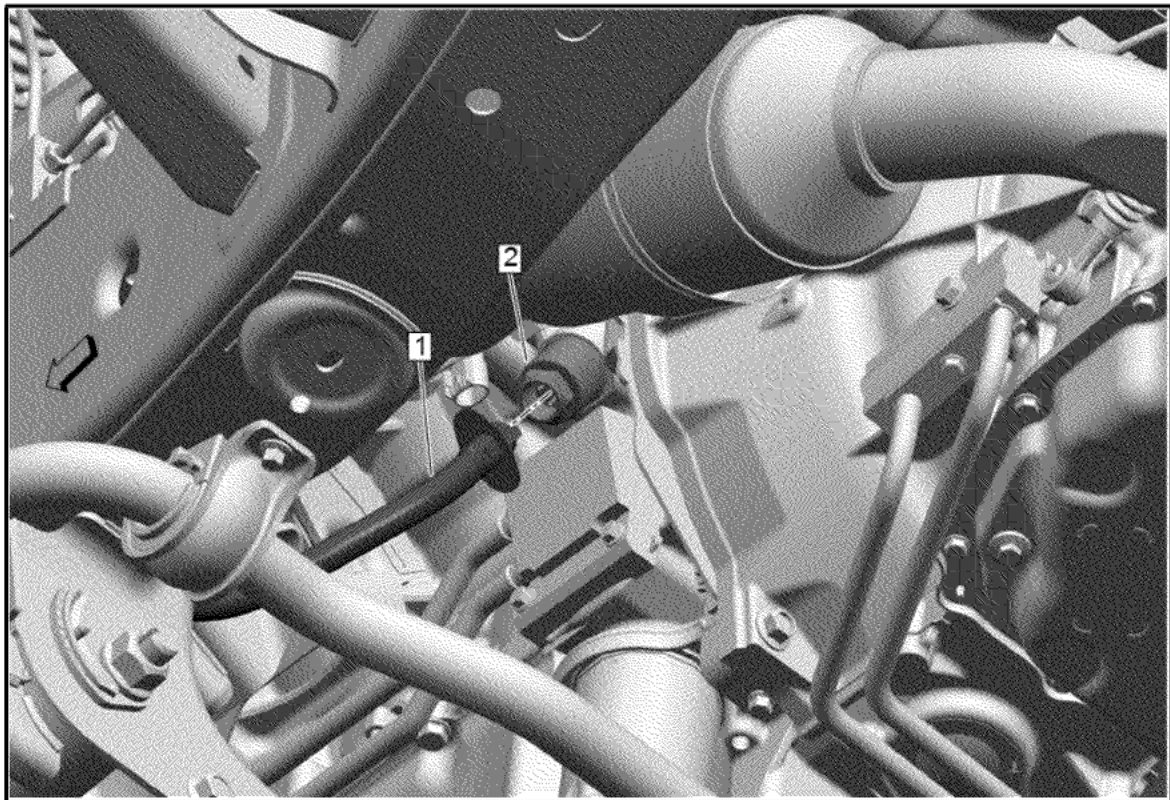

31. { If equipped } Engine Coolant Heater Cord (1) @ Engine Coolant Heater » Disconnect

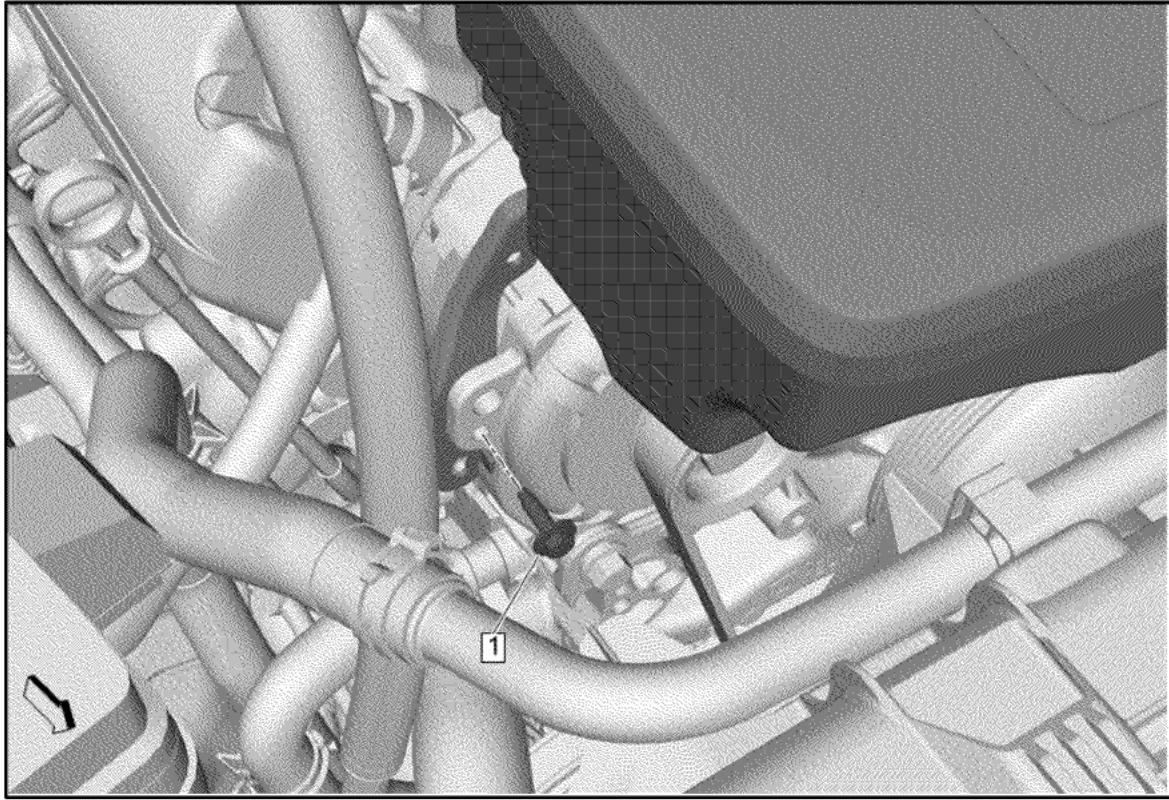

© 2025 General Motors. All rights reserved.

32. Air Cleaner Outlet Duct Bracket Bolt (1) » Remove

33. Engine Wiring Harness @ Air Cleaner Outlet Duct Bracket » Remove

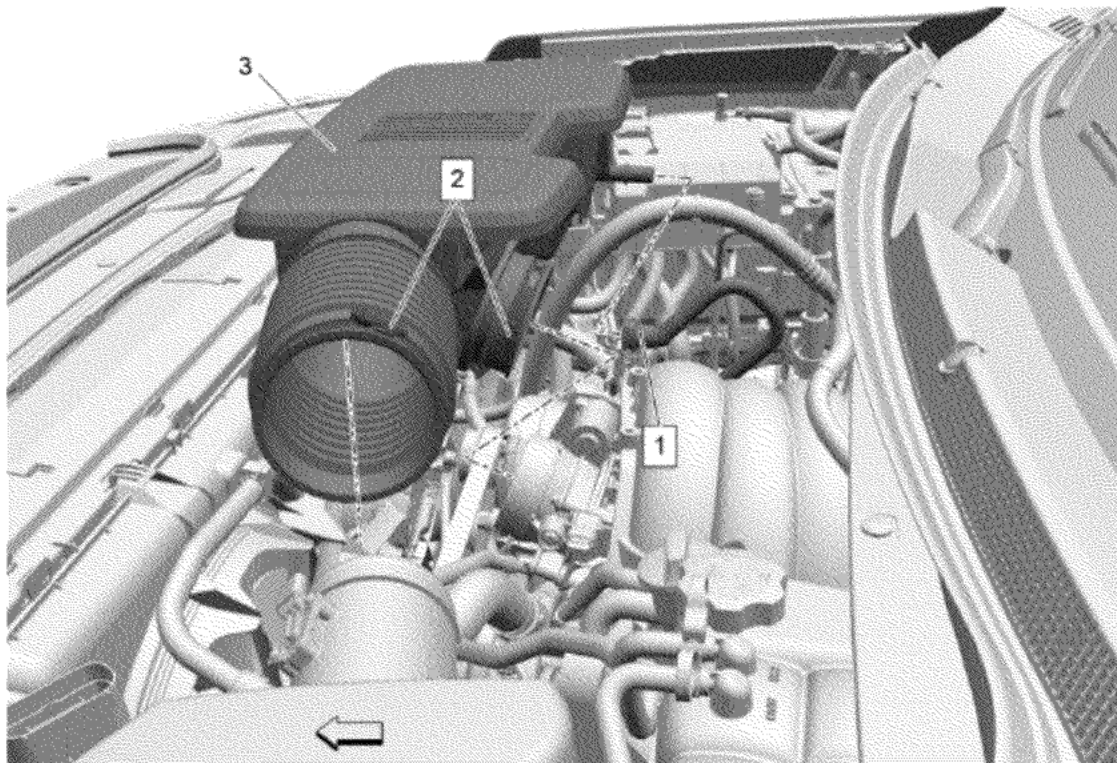

© 2025 General Motors. All rights reserved.

34. Air Cleaner Outlet Duct Clamp (2) » Loosen [2x]
35. Positive Crankcase Ventilation Fresh Air Tube (1) » Disconnect — [Plastic Collar Quick Connect Fitting Service](#)
36. Air Cleaner Outlet Duct (3) » Remove

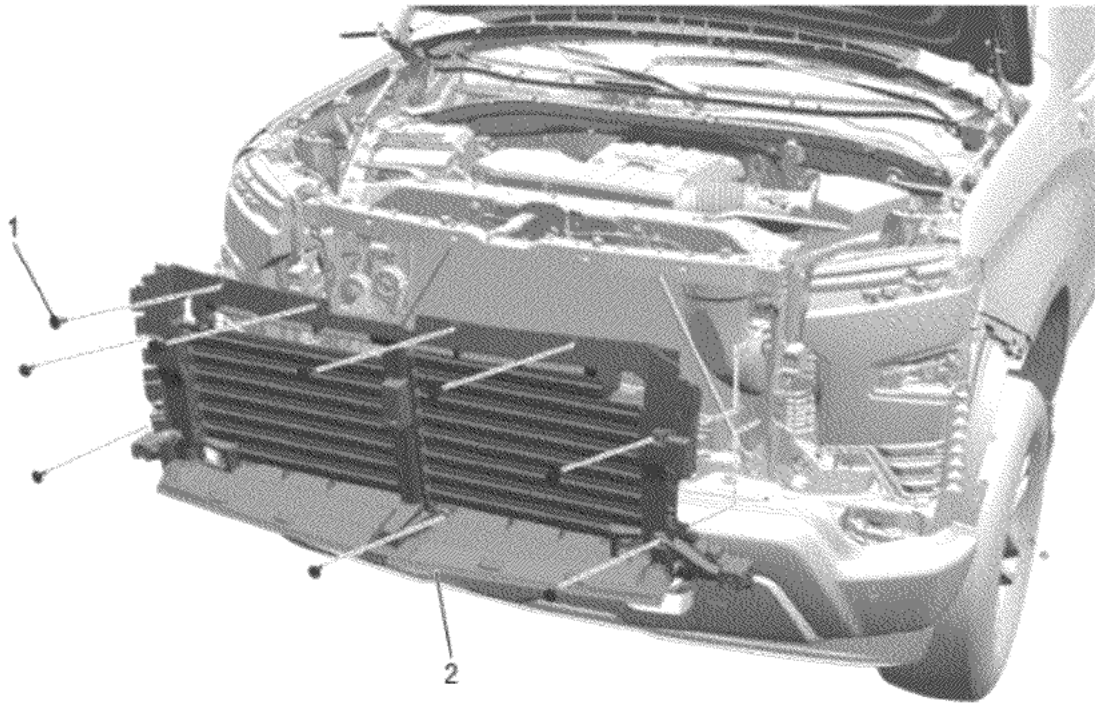

37. Front Bumper Shutter Bolt (1) » Remove [9x]
38. { If equipped } Release the 2 wiring harness retainers holding the camera nozzle hose.
39. { If equipped } Remove the front driver info camera wiring harness retainer.
40. Tip the top of the front bumper shutter (2) slightly forward and pull the shutter upward over the impact bar.
41. Disconnect the electrical connector.
42. { If equipped } Disconnect and reposition the lower shutter harness.

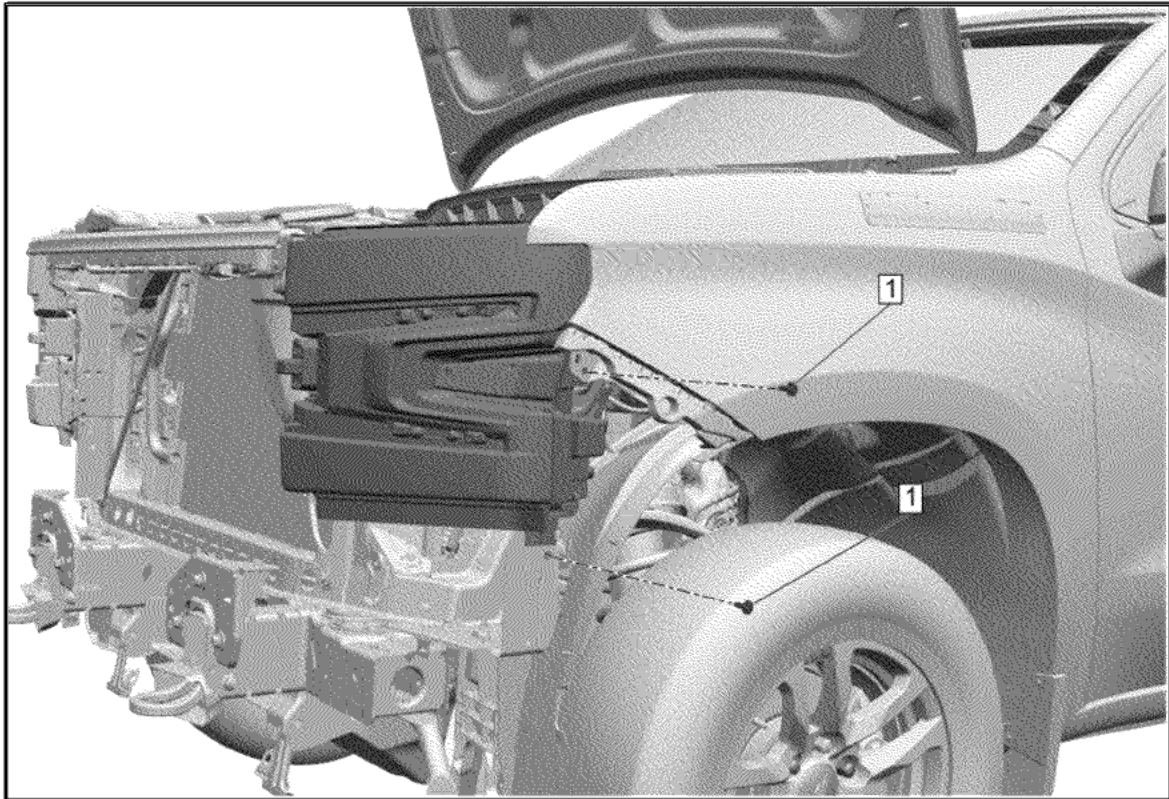

43. Headlamp Bolt - Left Side and Right Side (1) » Remove [4x]

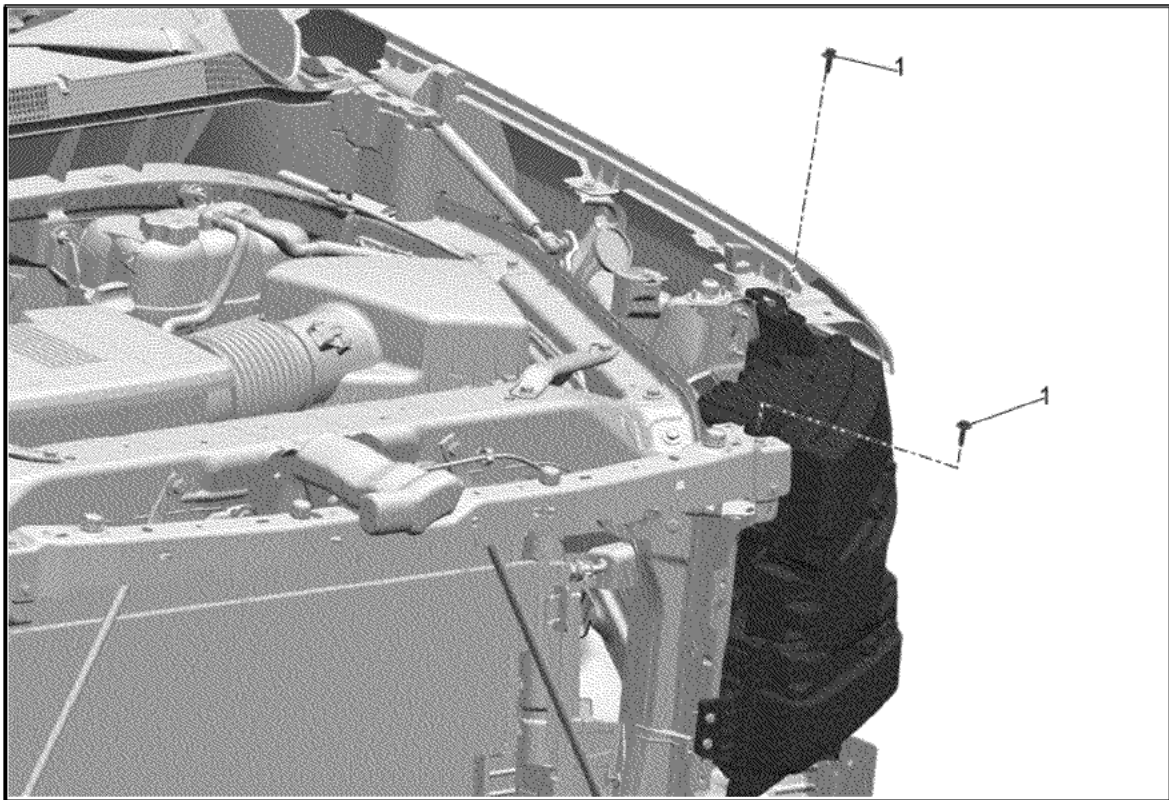

44. Headlamp Bolt - Left Side and Right Side (1) » Remove [4x]

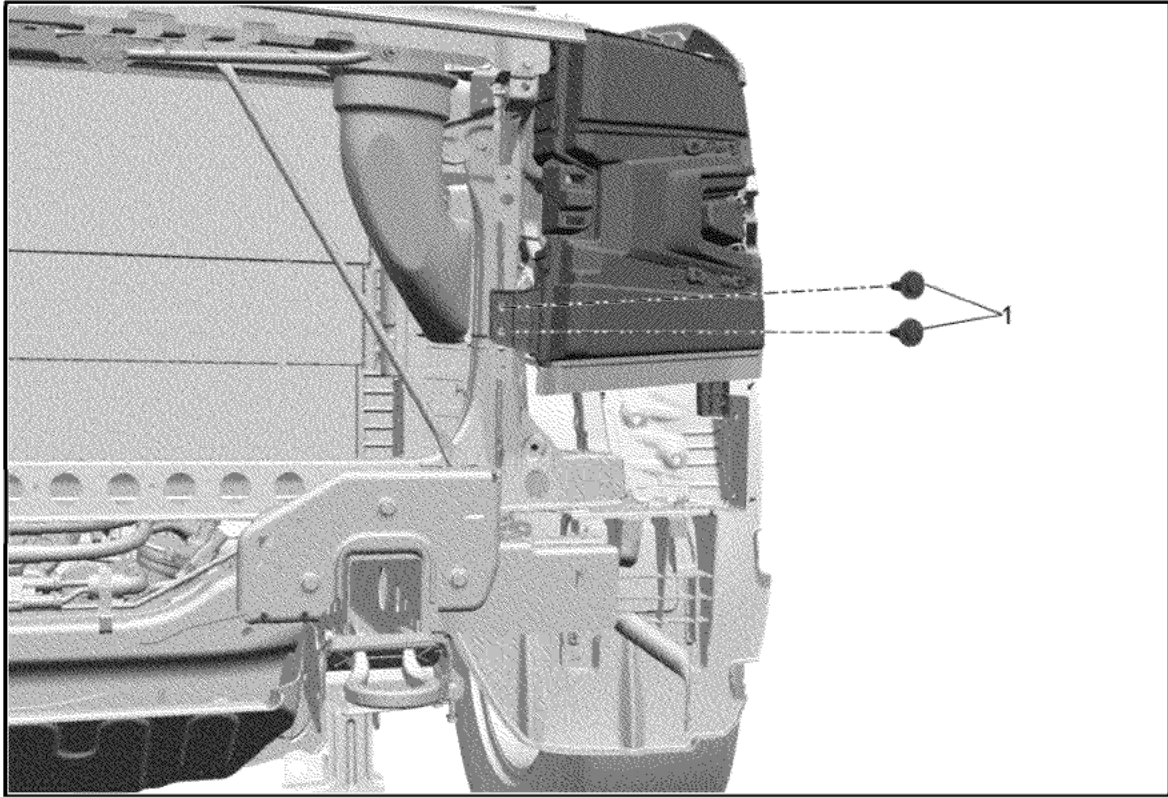

© 2025 General Motors. All rights reserved.

45. Headlamp Bolt - Left Side and Right Side (1) » Remove [4x]

46. Disconnect all electrical connectors.

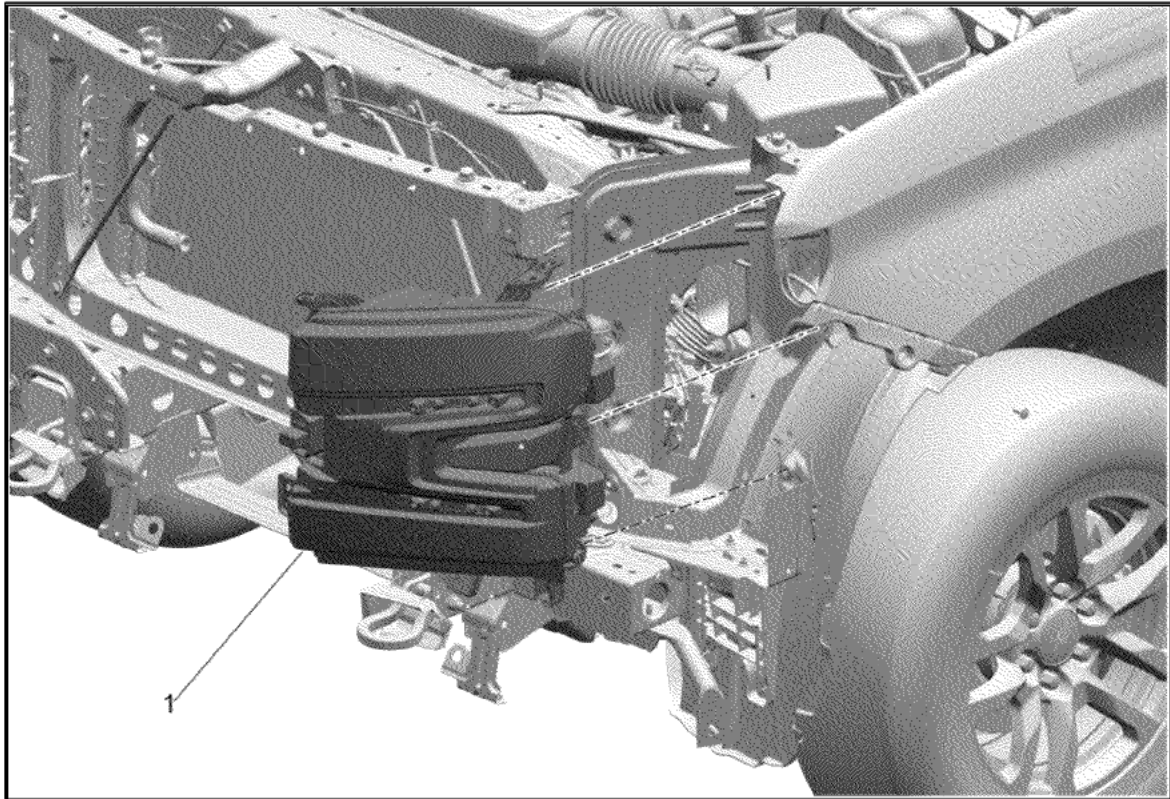

© 2025 General Motors. All rights reserved.

47. Headlamp - Left Side and Right Side (1) » Remove [2x]

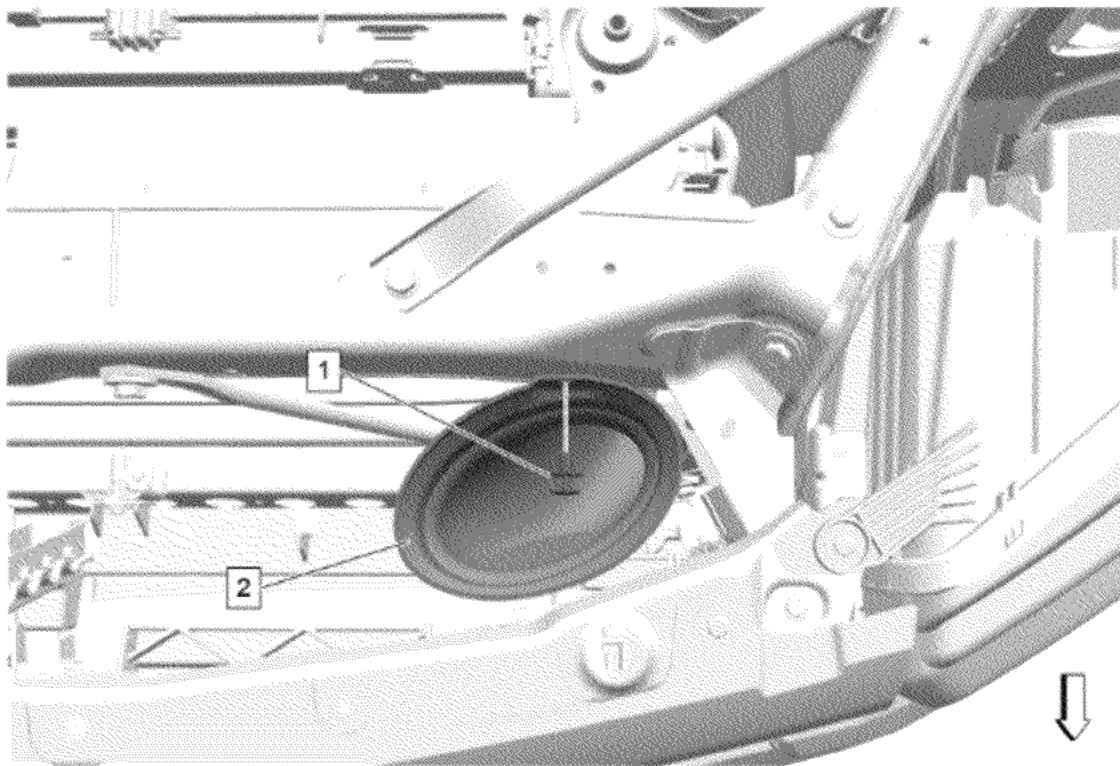

48. Intake Air Duct Retainer (1) » Remove

49. Intake Air Duct (2) » Remove

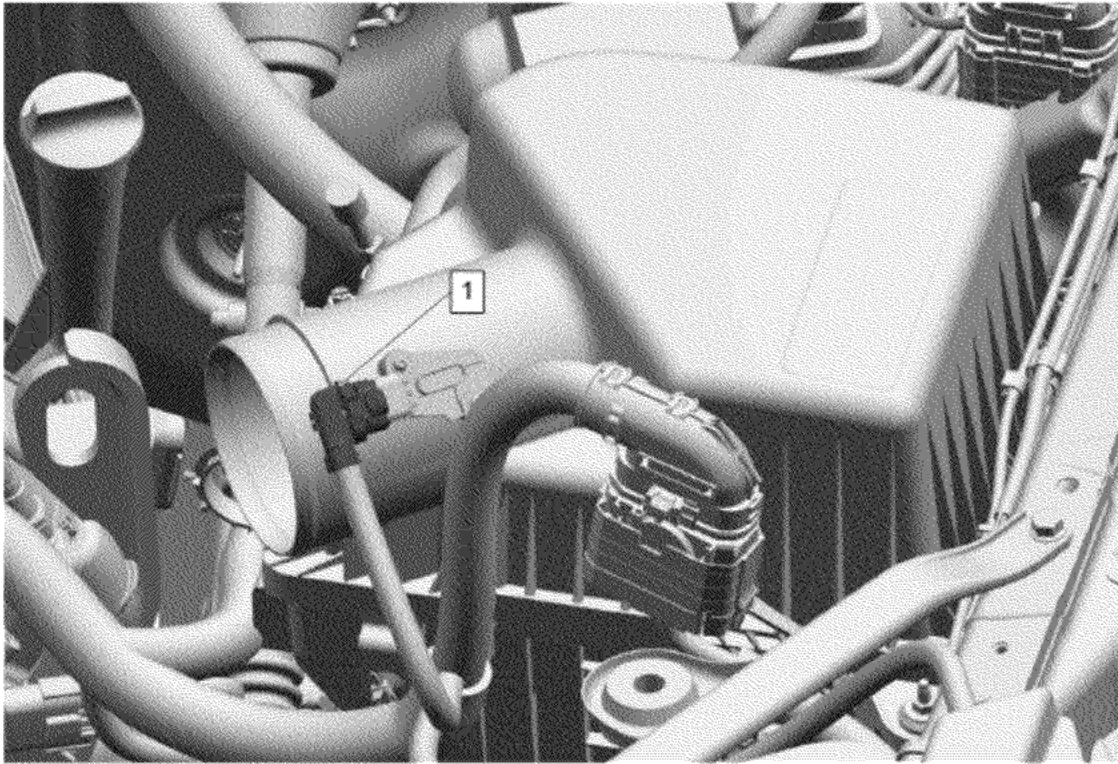

© 2025 General Motors. All rights reserved.

50. Disconnect the mass airflow sensor electrical connector (1) and remove all engine wiring harnesses from the air cleaner assembly.

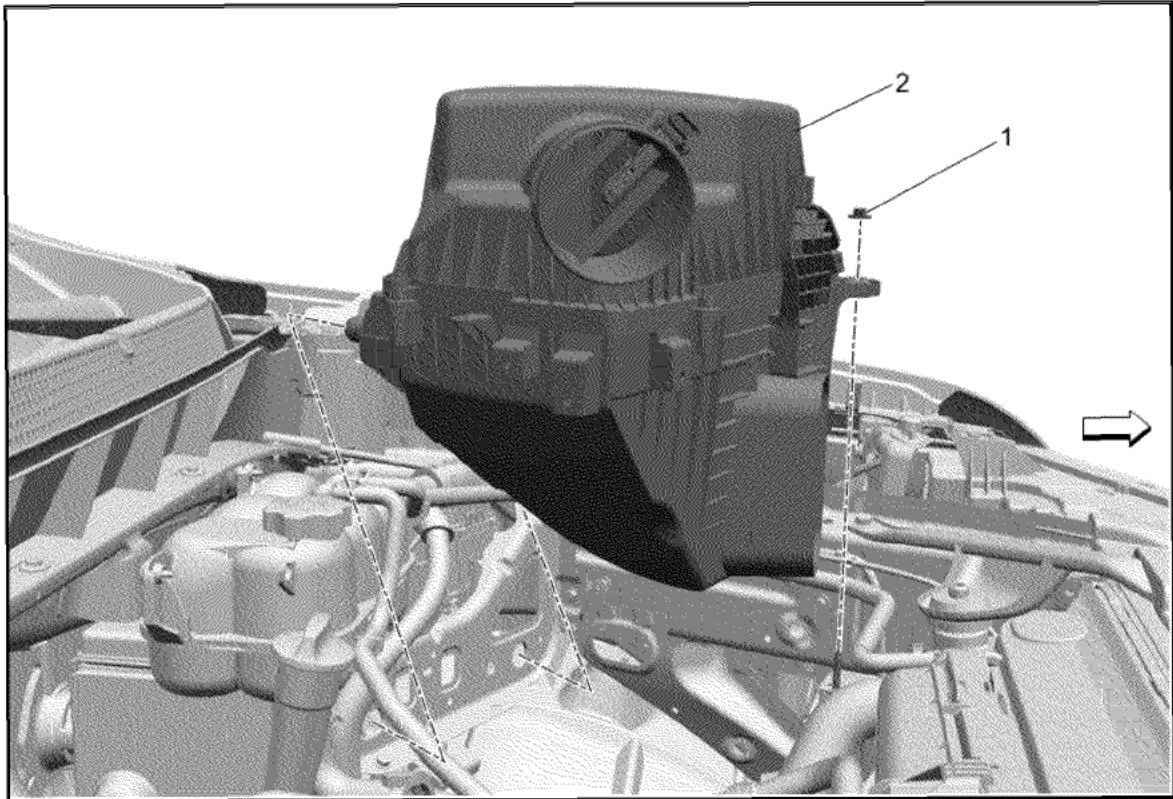

- 51. Air Cleaner Nut (1) » Remove
- 52. Air Cleaner Assembly (2) » Remove

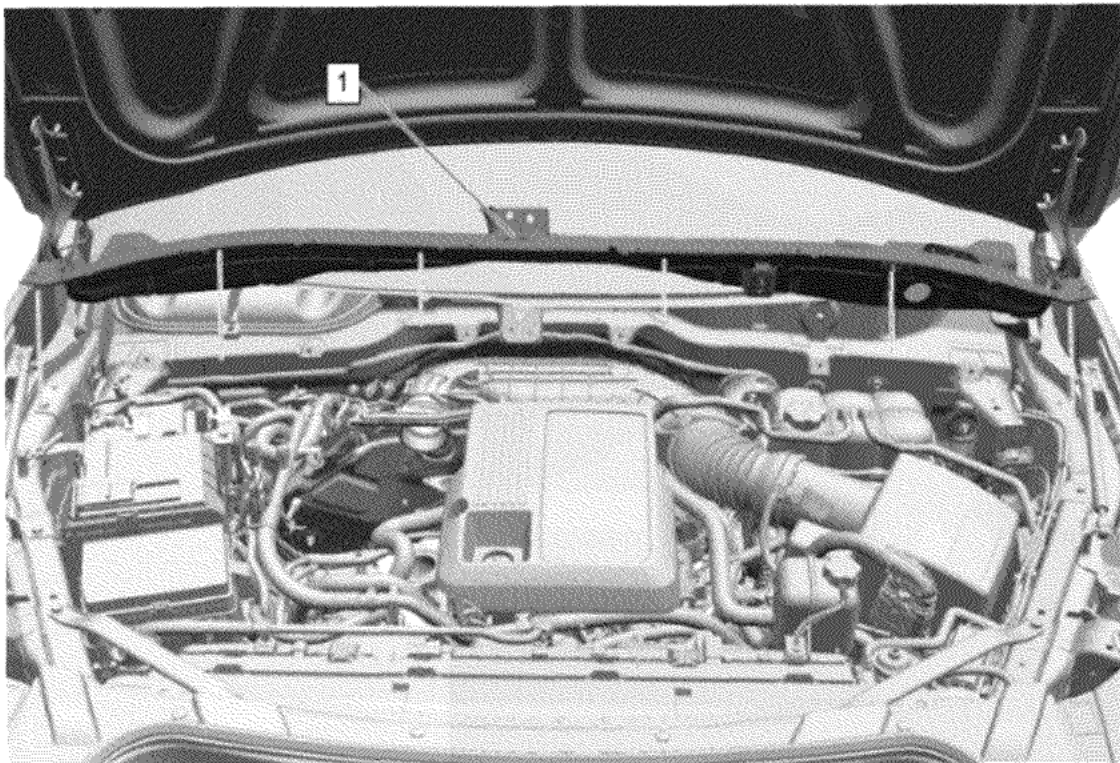

53. Plenum Front Panel Outer Reinforcement (1) » Remove — [Plenum Front Panel Outer Reinforcement Removal and Installation](#)

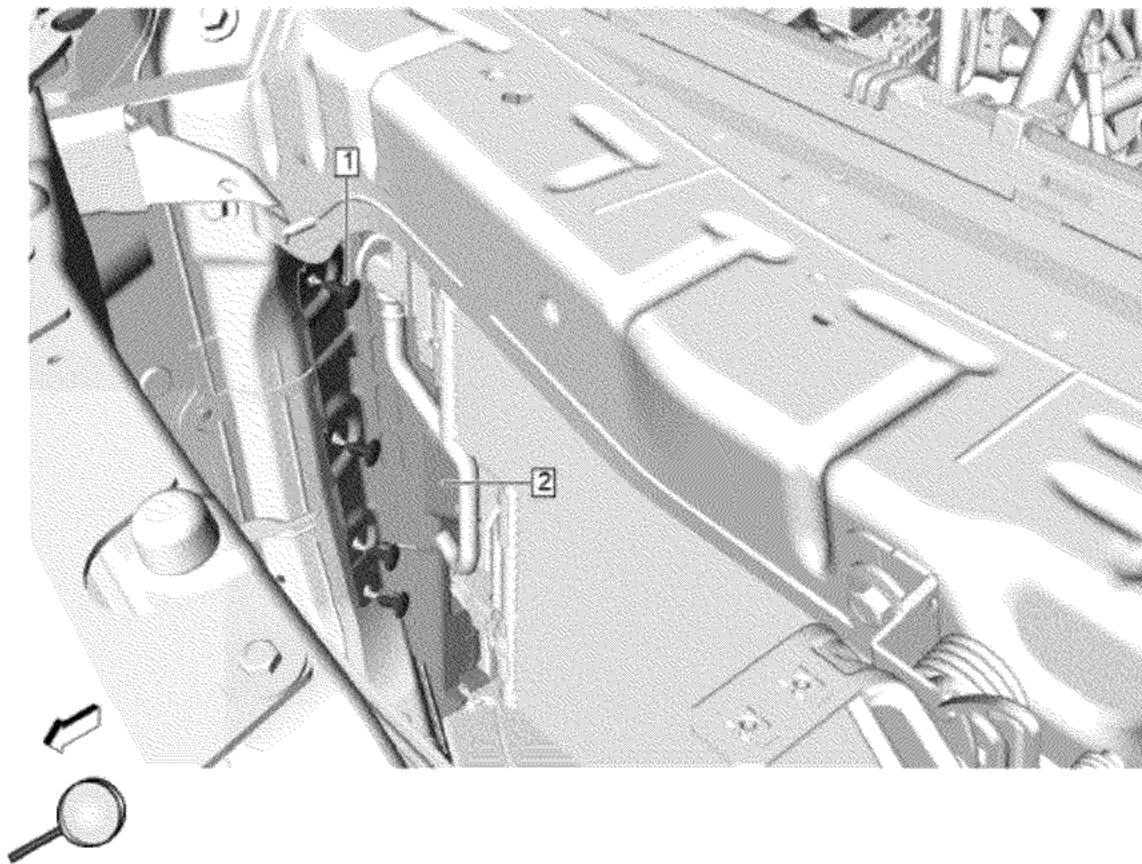

© 2025 General Motors. All rights reserved.

Note: Some components not shown for graphic clarity.

54. Radiator Air Side Baffle Retainer (1) » Remove [4x]

55. Radiator Air Side Baffle - Right Side (2) » Remove

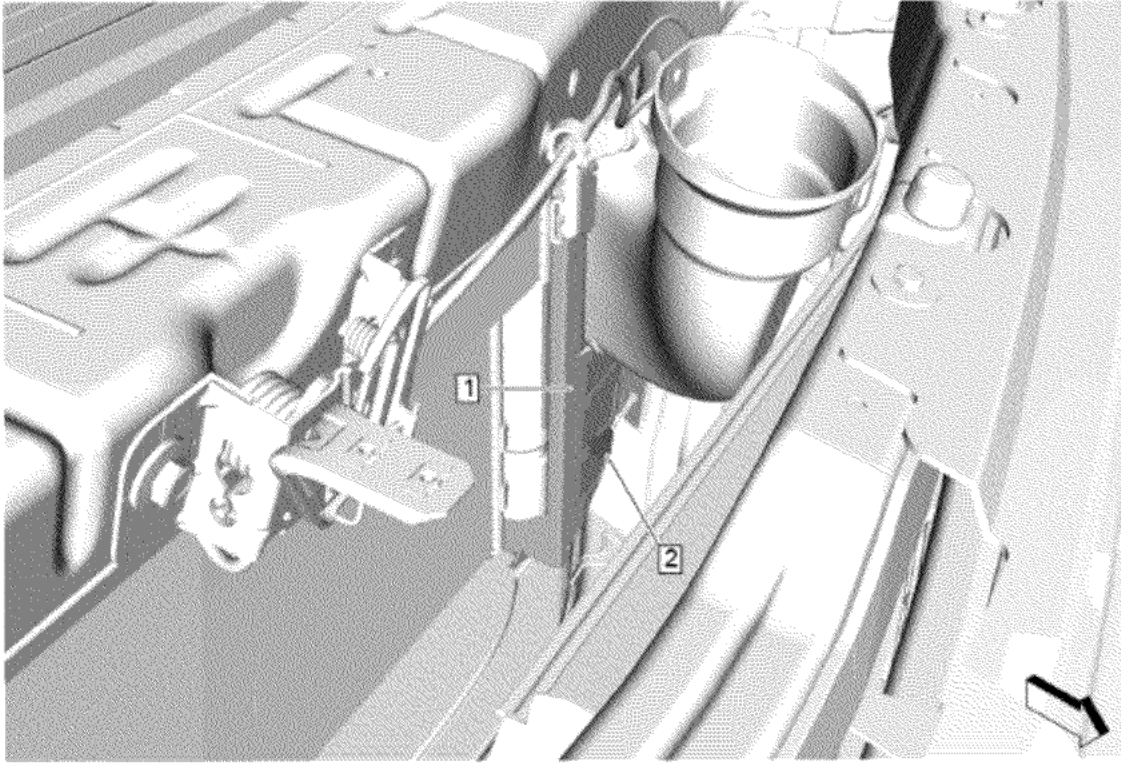

- 56. Radiator Air Side Baffle Retainer (2) » Remove
- 57. Radiator Air Side Baffle - Left Side (1) » Remove

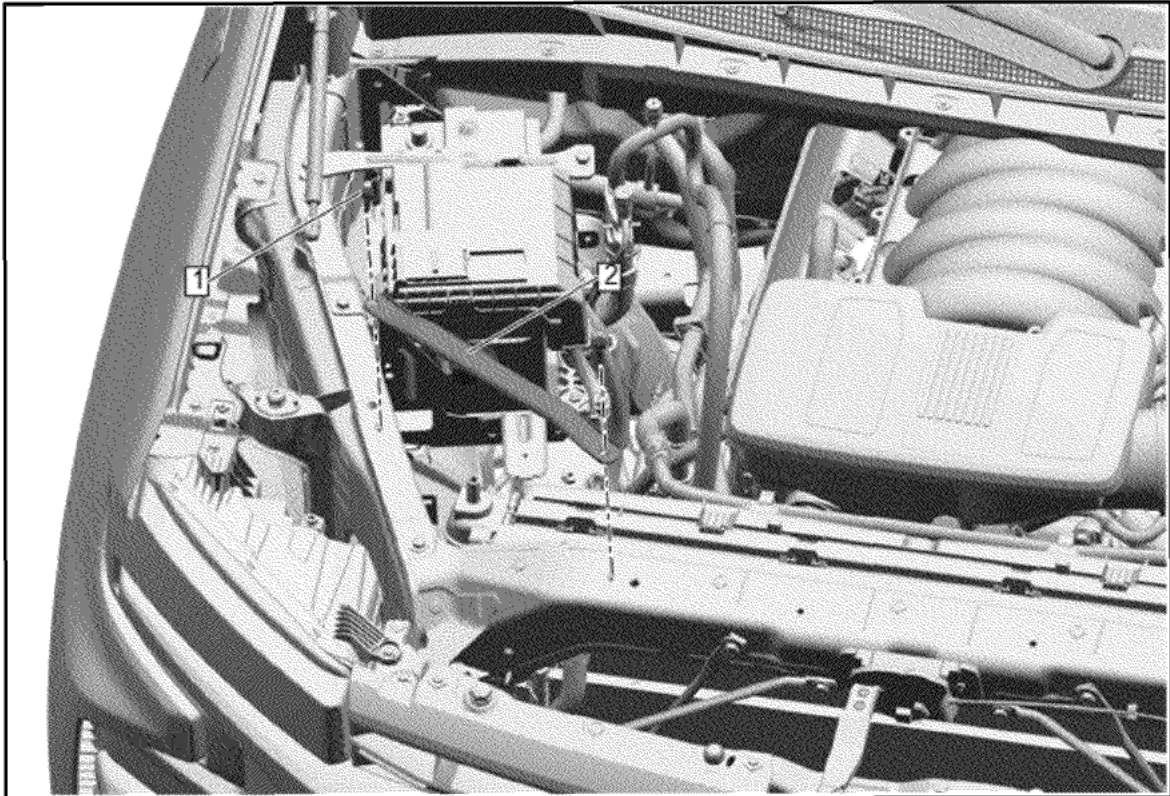

© 2025 General Motors. All rights reserved.

- 58. Front End Sheet Metal Cross Brace Bracket Bolt - Left Side and Right Side (1) Remove [4x]
- 59. Front End Sheet Metal Cross Brace Bracket - Left Side and Right Side (2) » Remove [2x]

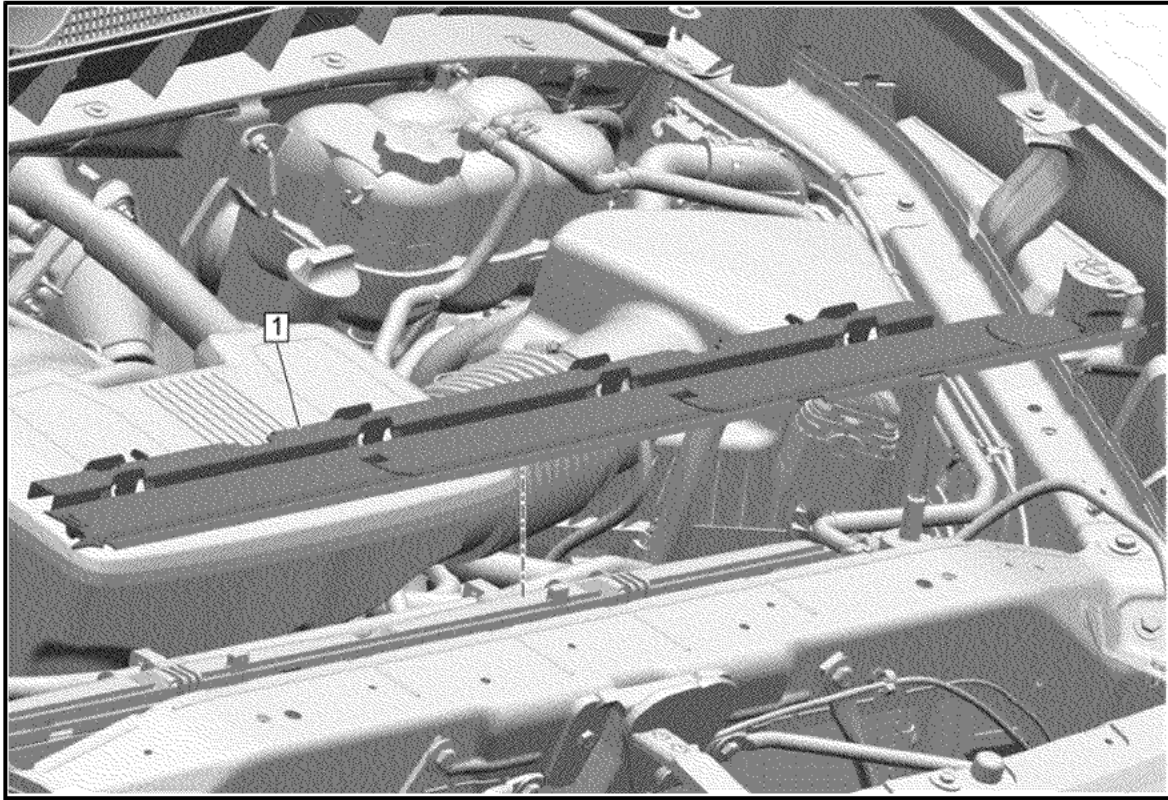

- 60. Radiator Air Upper Baffle (1) @ Radiator Air Side Baffle» Unclip
- 61. Radiator Air Upper Baffle (1) @ Radiator » Unclip

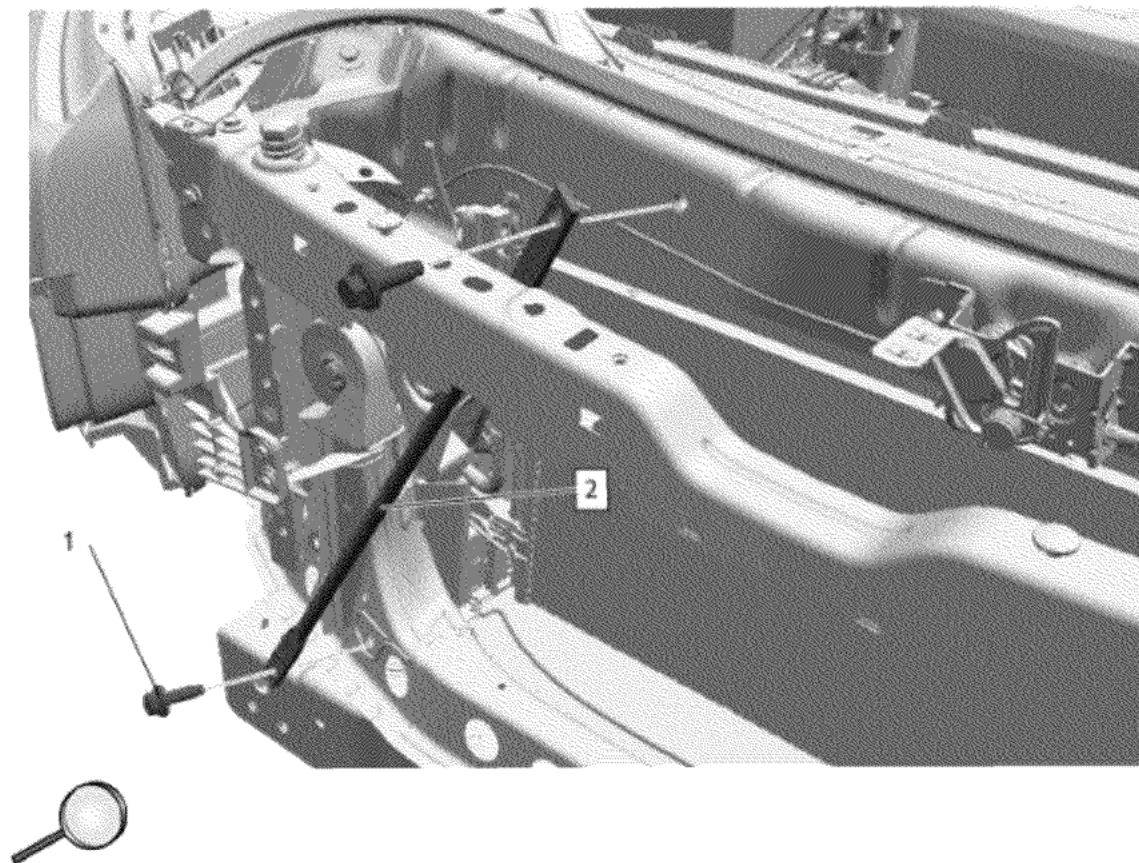

© 2025 General Motors. All rights reserved.

Note: Right side shown, left side similar.

62. Front End Sheet Metal Diagonal Brace Bolt - Left Side and Right Side (1) @ Radiator Support » Remove [4x]
63. Front End Sheet Metal Diagonal Brace - Left Side and Right Side (2) @ Radiator Support » Remove [2x]

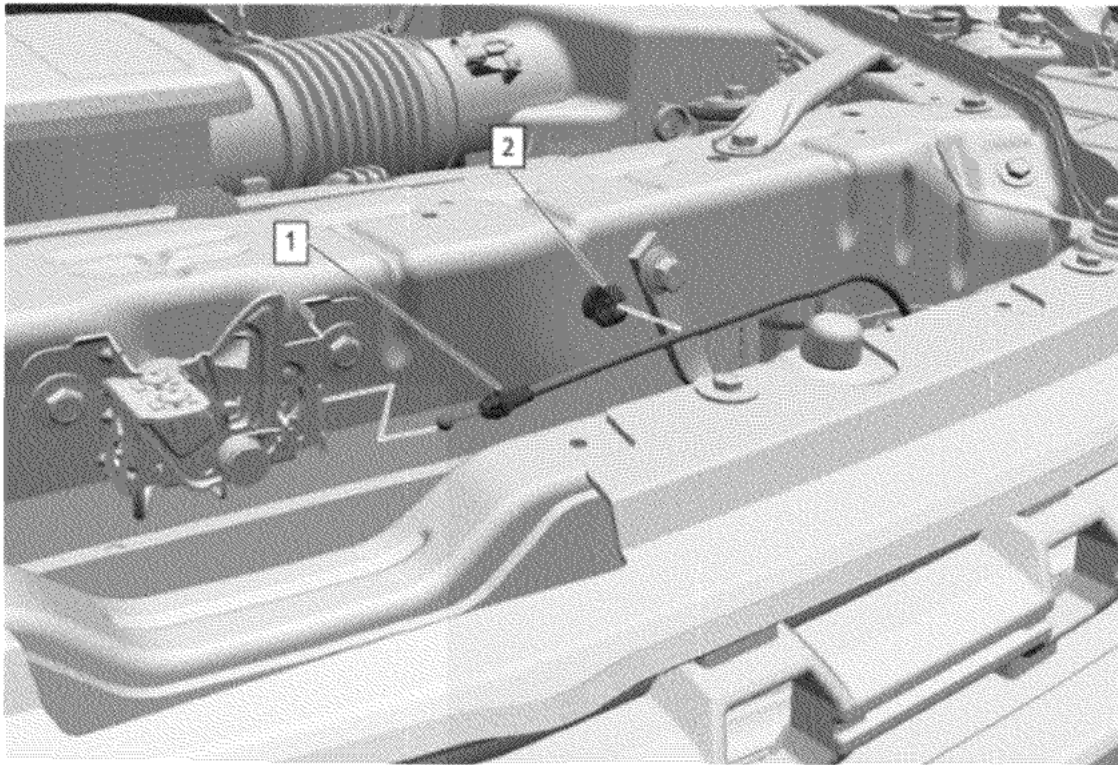

64. Reposition the hood primary latch release cable (1) from the upper tie bar retainer (2).
65. Hood Primary Latch Release Cable (1) » Disconnect @ Hood Primary Latch
66. Disconnect the electrical connector.

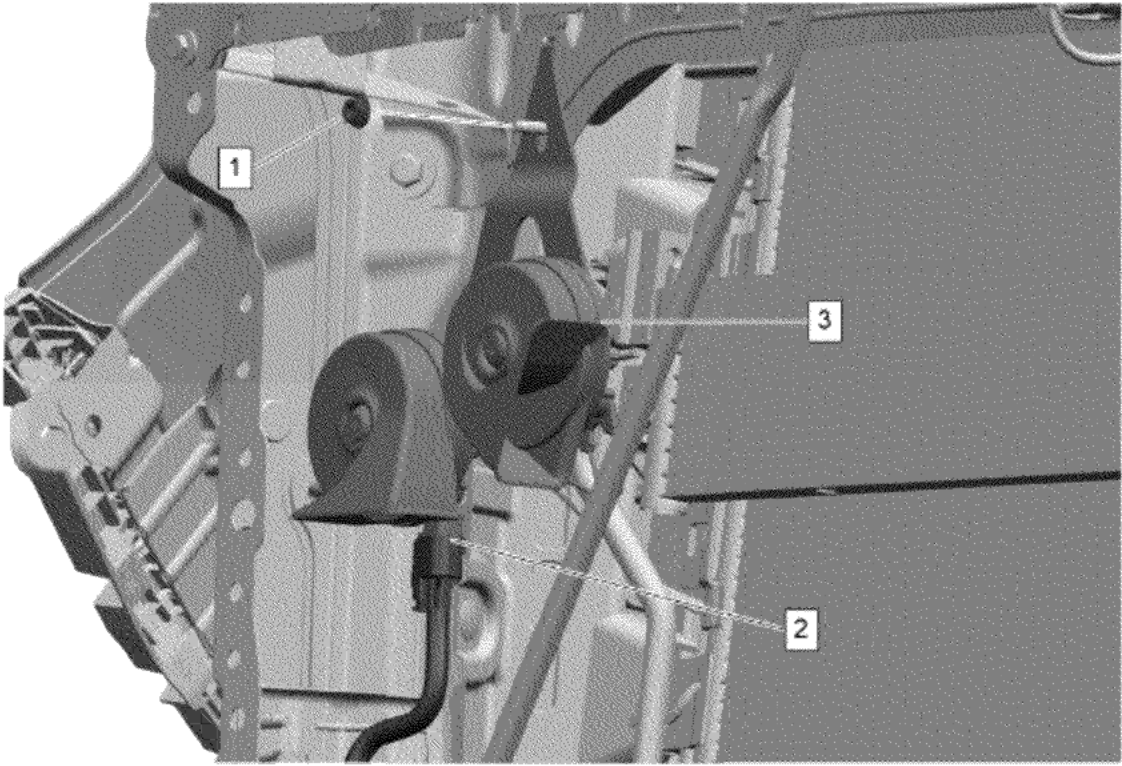

67. Electrical Connector (2) » Disconnect

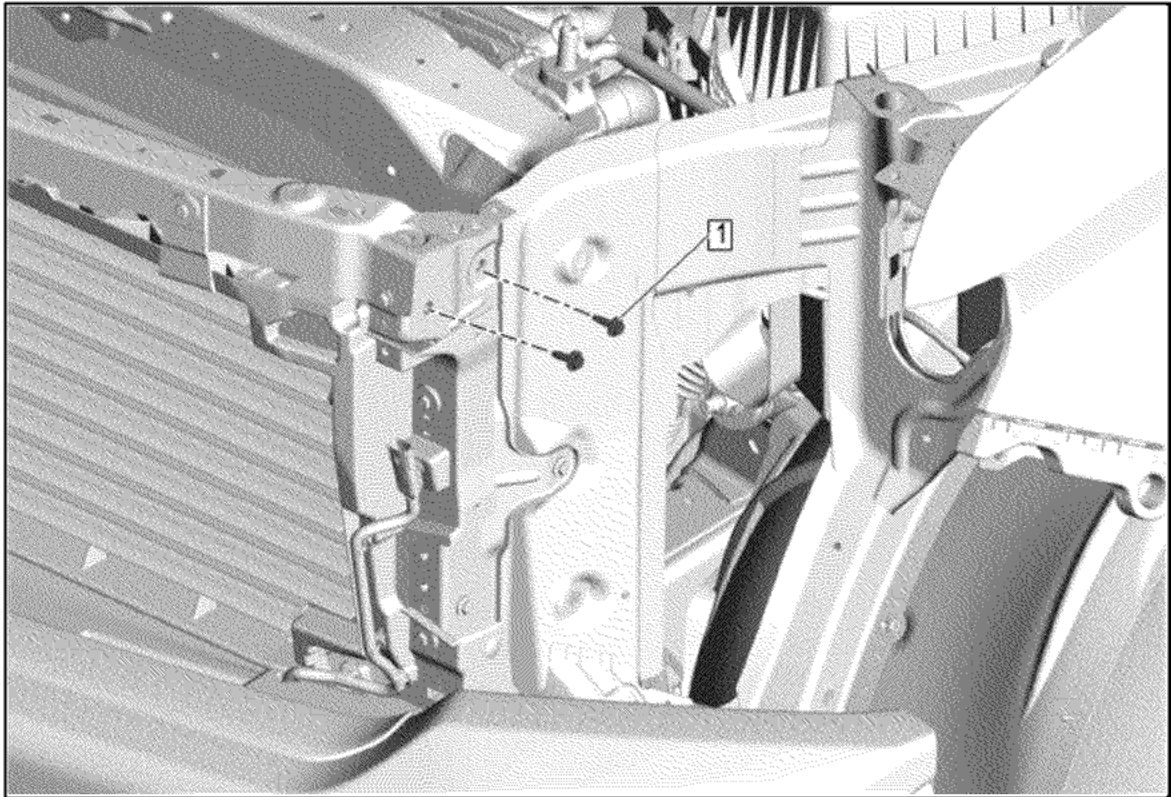

68. Front End Upper Tie Bar Bolt - Left Side and Right Side (1) @ Headlamp Bracket » Remove [4x]

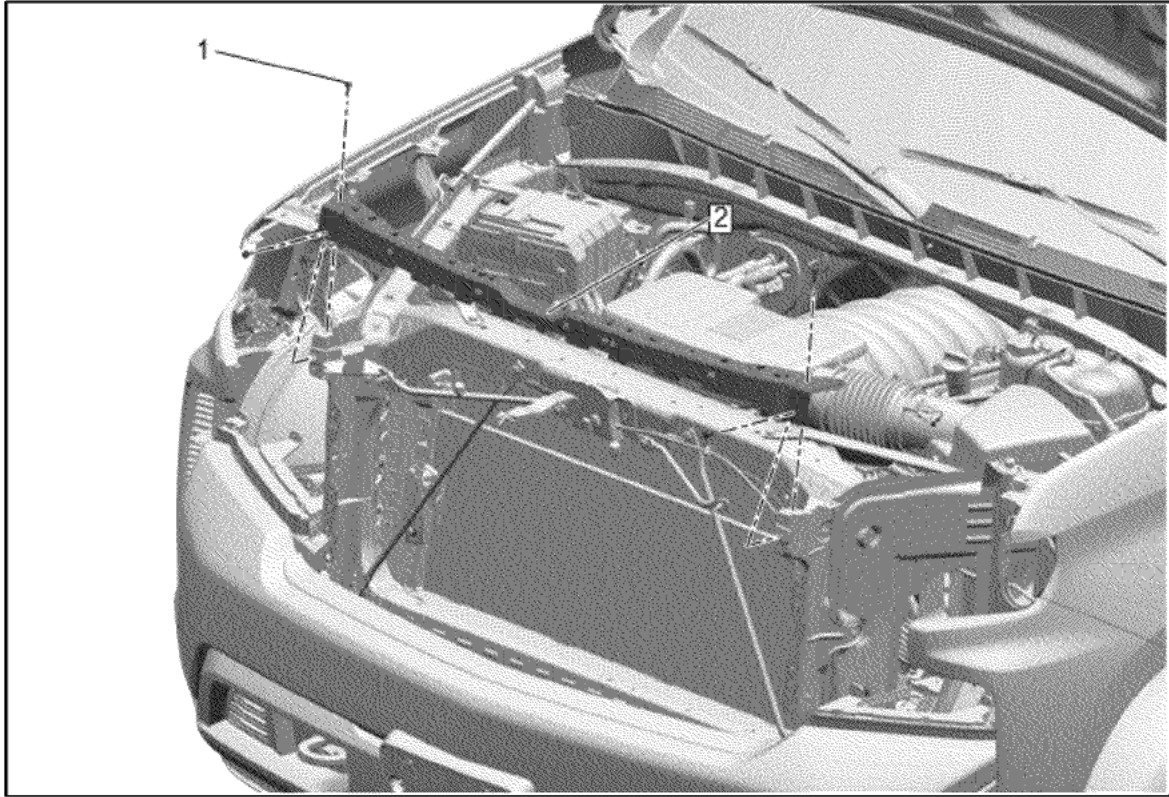

69. Front Bumper Fascia Center Support Bolt (1) » Remove [4x]
70. Front Grille Support Reinforcement (2) » Remove

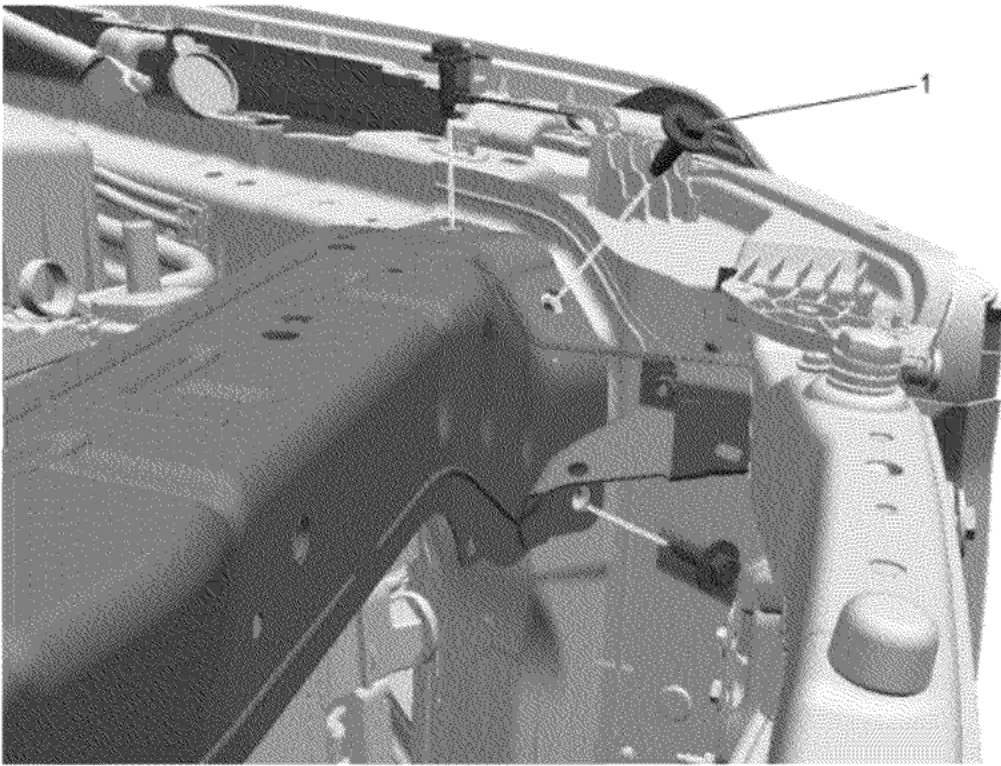

71. Front End Upper Tie Bar Bolt (1) » Remove [3x]

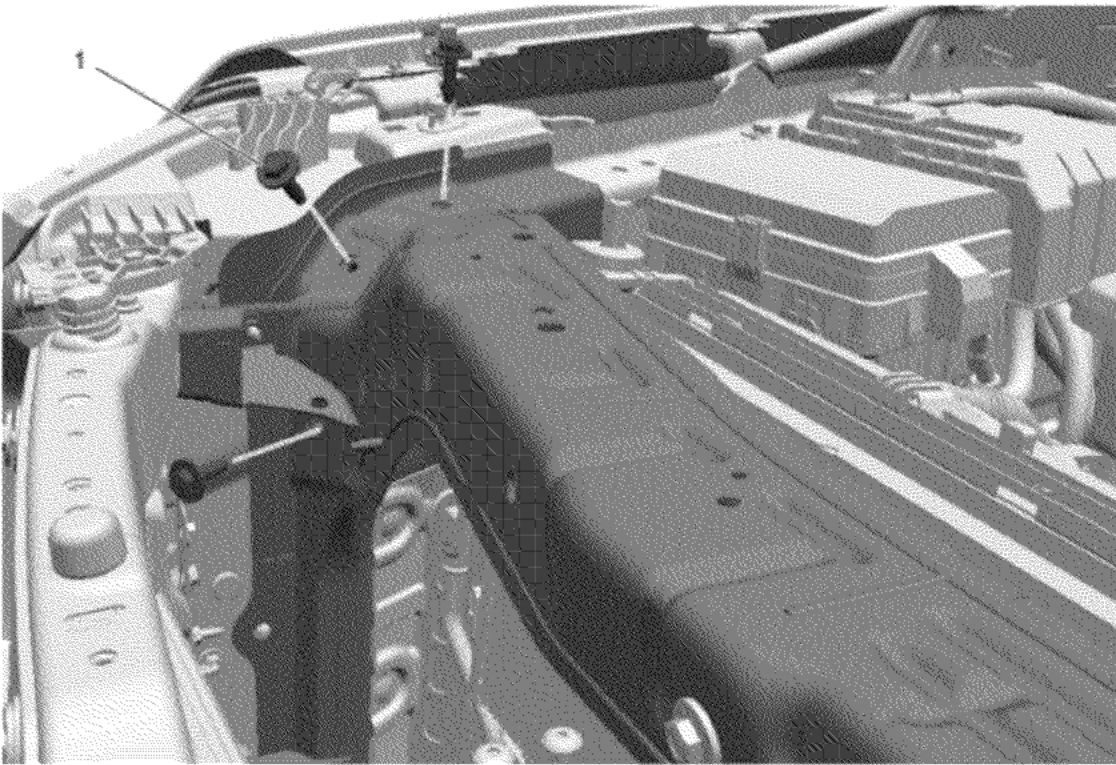

72. Front End Upper Tie Bar Bolt (1) » Remove [3x]

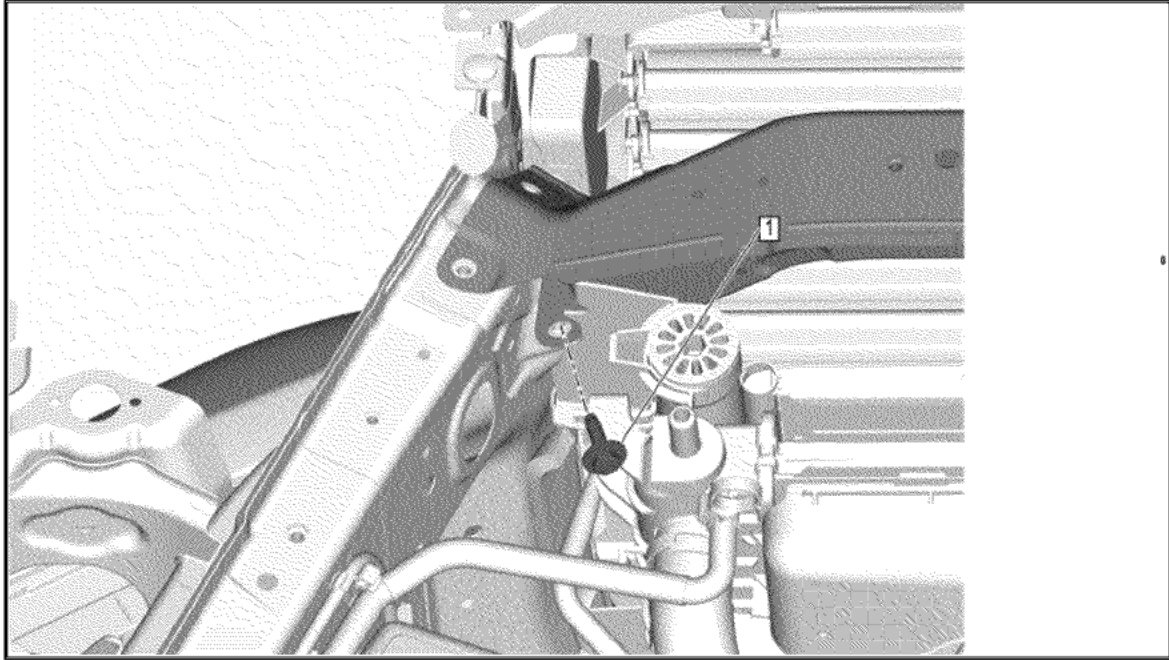

73. Front End Upper Tie Bar Bolt - Left Side (1) » Remove

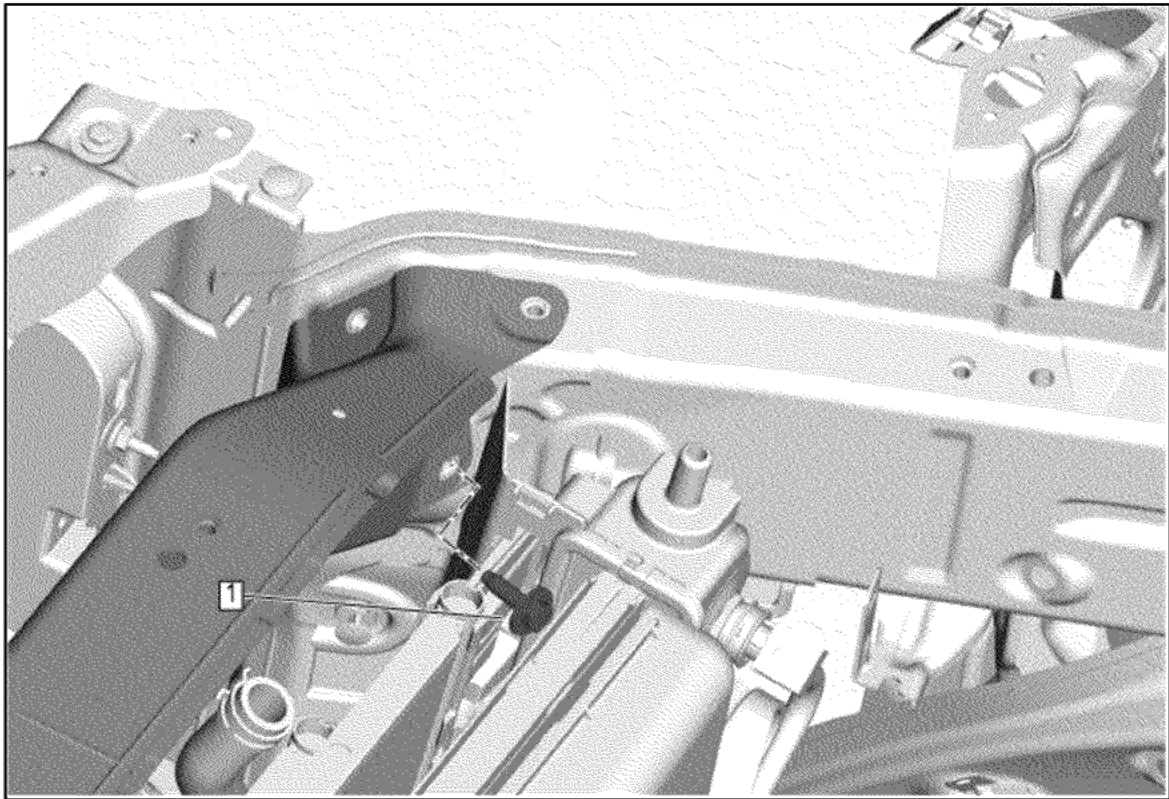

74. Front End Upper Tie Bar Bolt - Right Side (1) » Remove

© 2025 General Motors. All rights reserved.

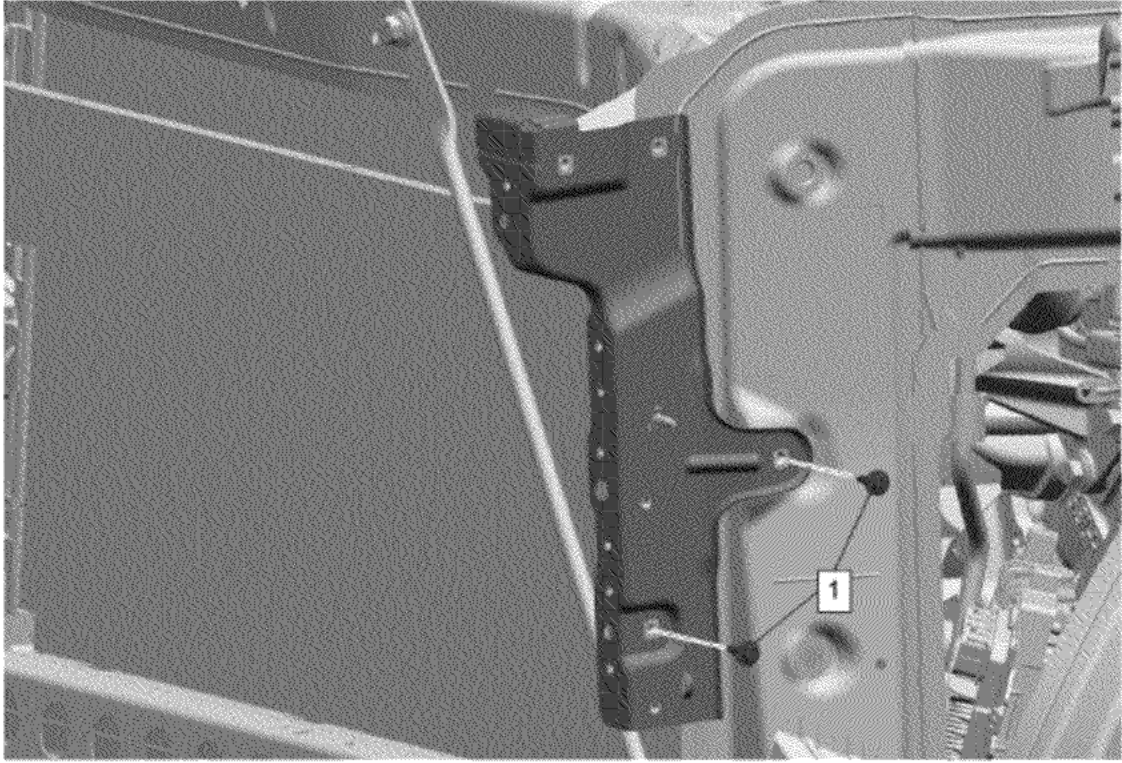

75. Headlamp Bracket Bolt - Left Side and Right Side (1) » Loosen [4x]

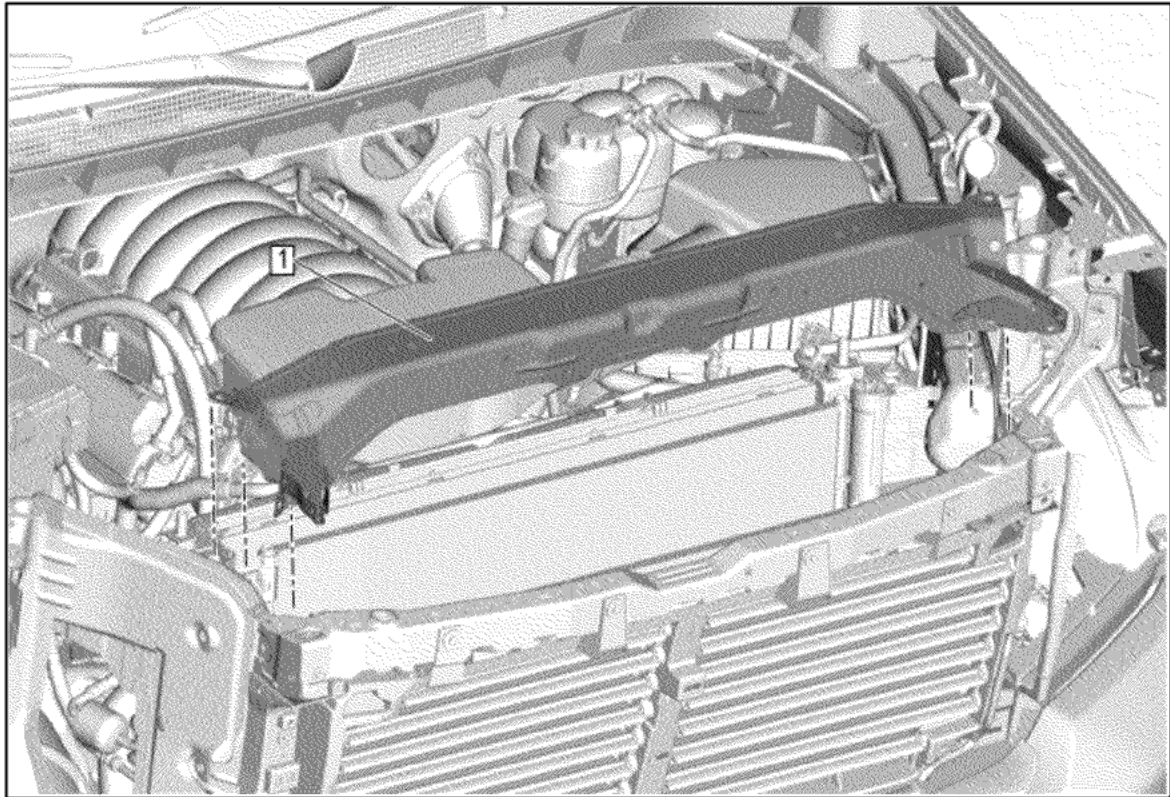

76. Front End Upper Tie Bar (1) » Remove
77. Disconnect the wiring harness.

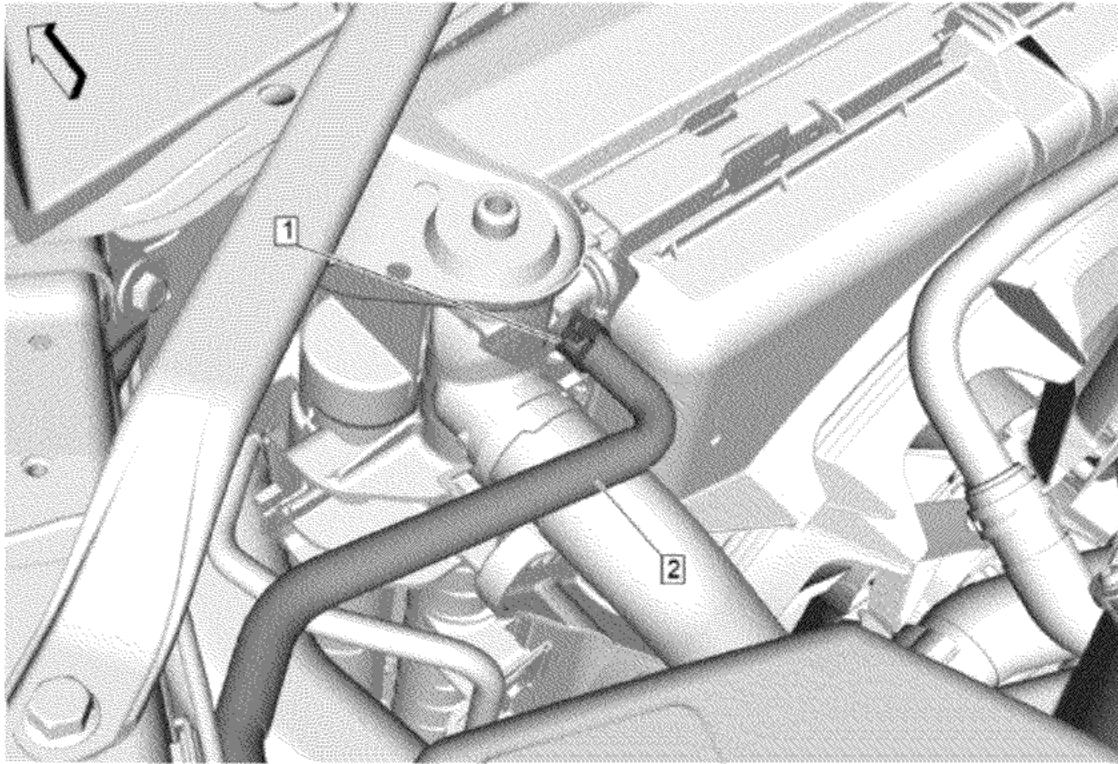

78. Radiator Surge Tank Inlet Hose Clamp (1) » Disengage — [Hose Clamp Replacement Guidelines - Spring Type](#)
79. Radiator Surge Tank Inlet Hose (2) @ Engine Radiator » Remove and position aside

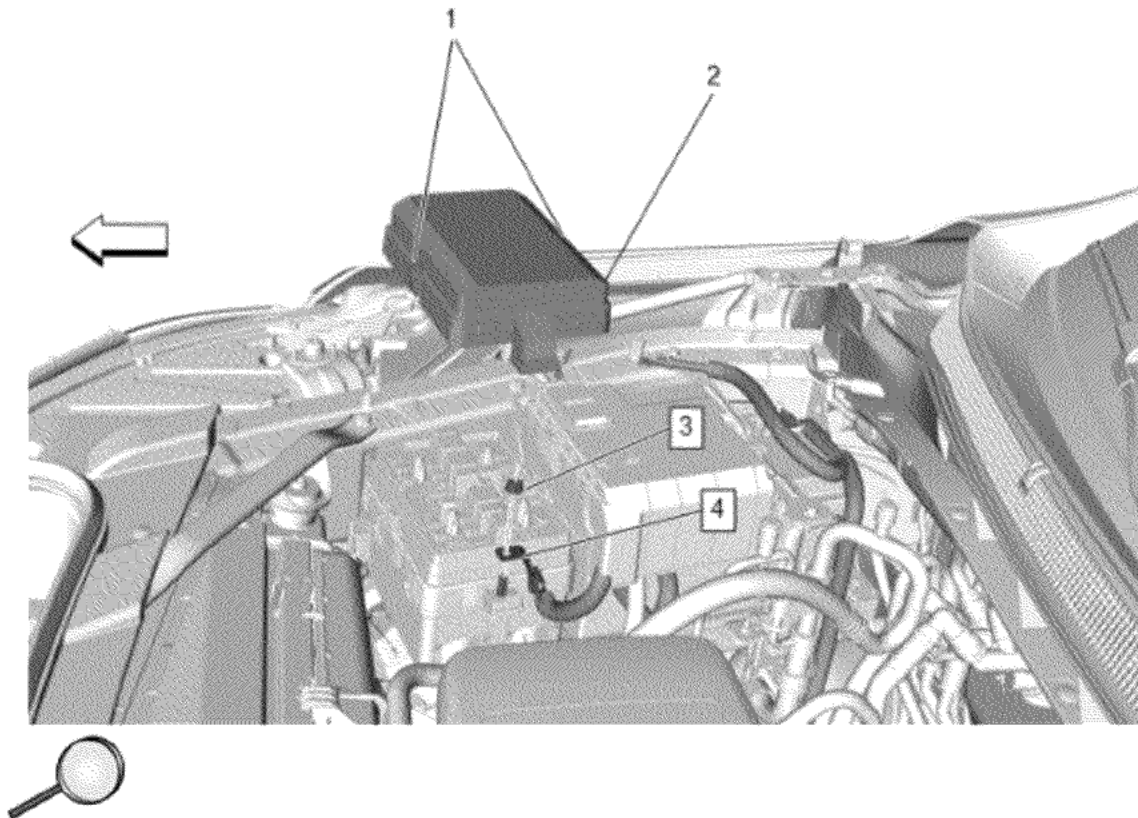

- 80. Retaining Tab (1) » Disengage [2x]
- 81. Engine Wiring Harness Junction Block Cover (2) » Remove
- 82. Battery Positive Cable Nut (3) » Remove
- 83. Starter Solenoid Cable (4) » Remove

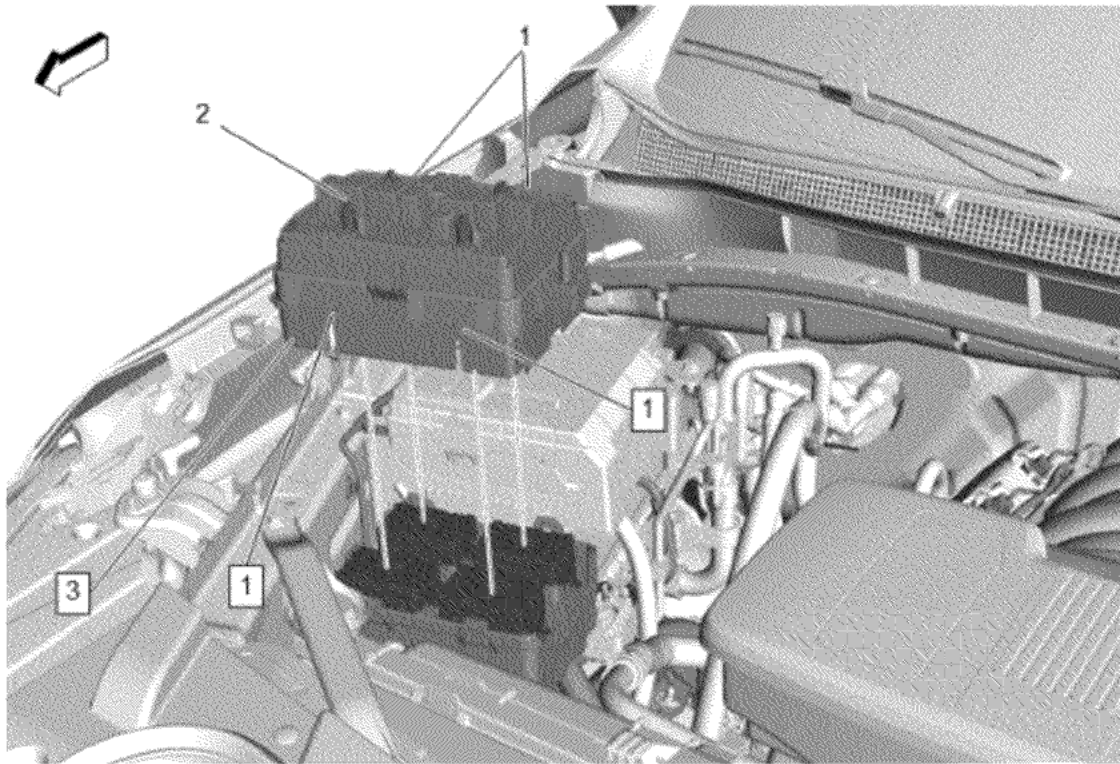

84. Engine Wiring Harness Junction Block Bolt (2) » Loosen [4x]
85. Retaining Tab (1) » Disengage [4x]
86. Engine Wiring Harness Junction Block (3) » Remove

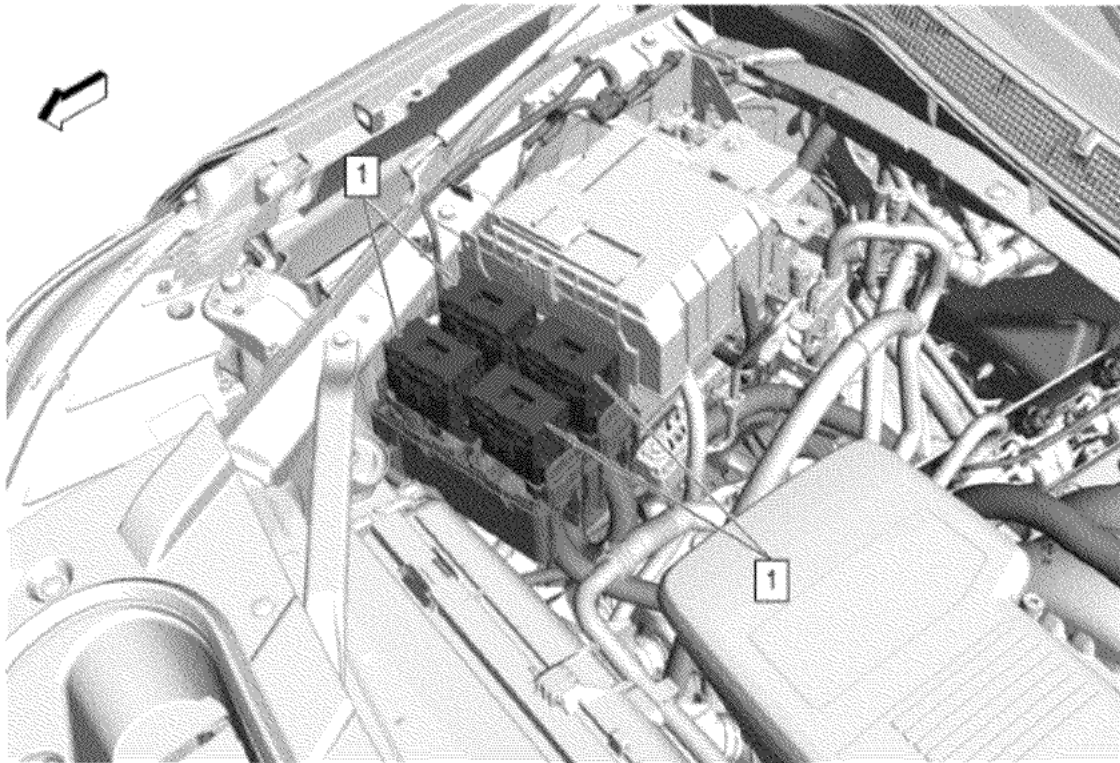

87. Electrical Connector (1) » Remove [4x]

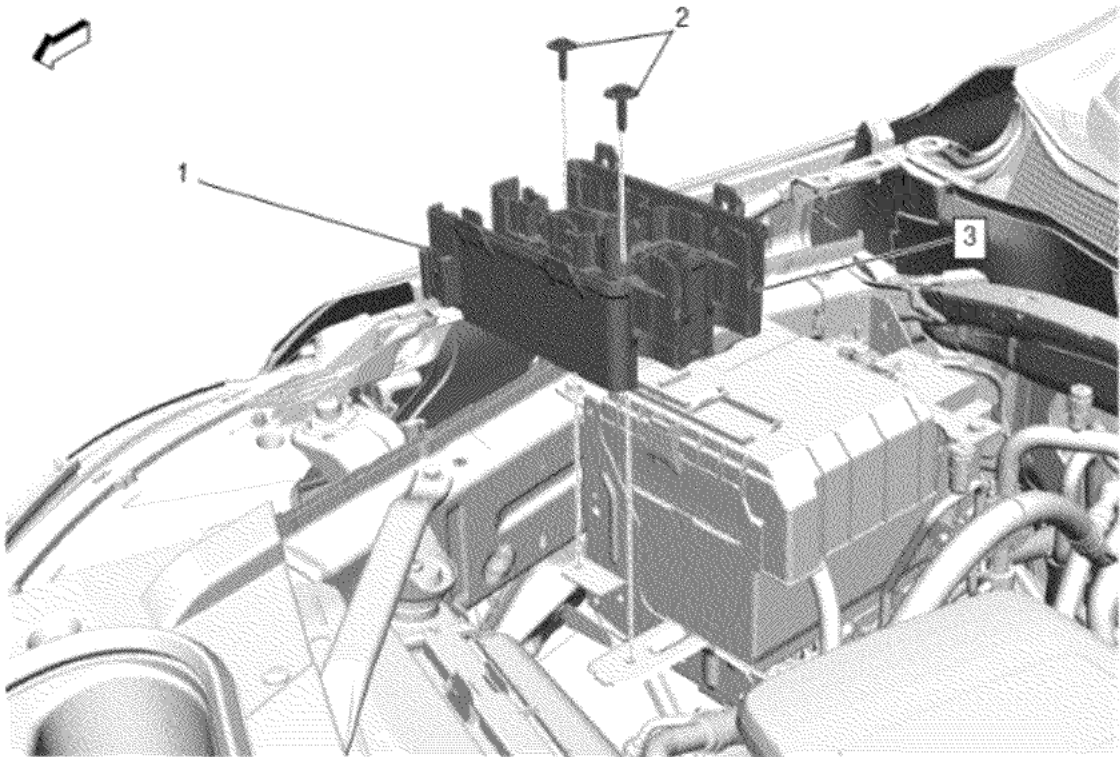

88. Engine Wiring Harness Fuse Block Bracket Bolt (2) » Remove [2x]

89. Retaining Tab (1) » Disengage
90. Engine Wiring Harness Fuse Block Bracket (3) » Remove

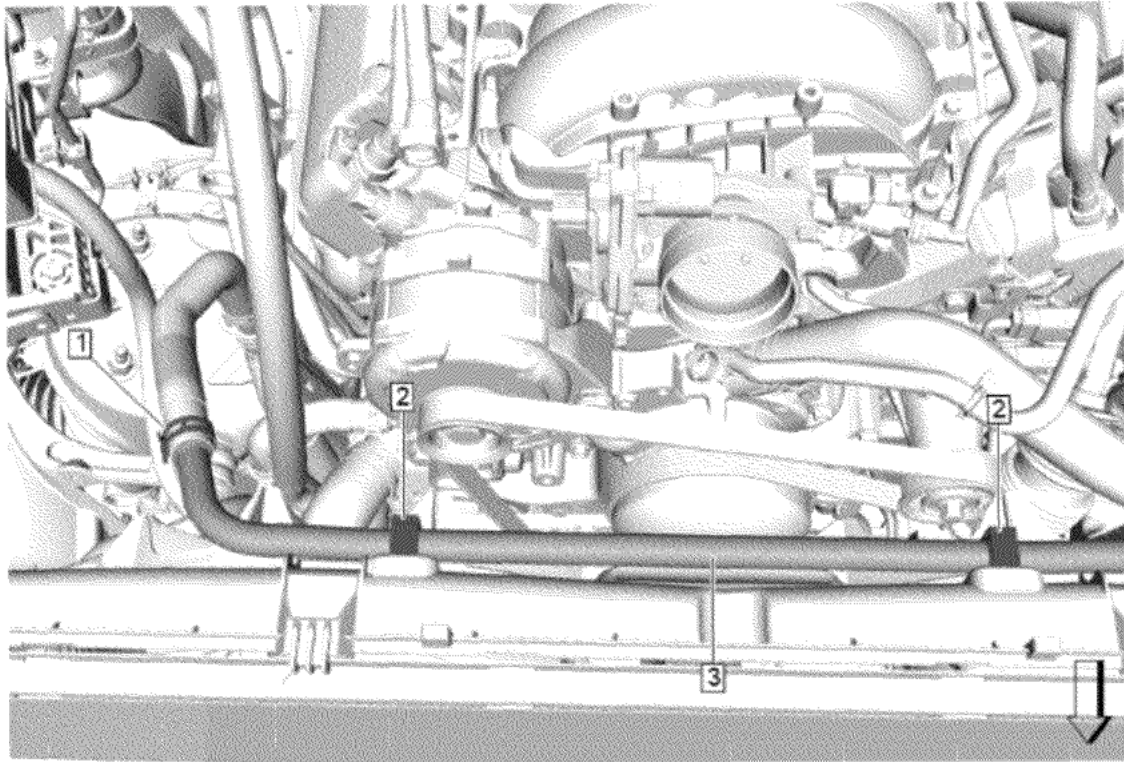

91. Heater Outlet Hose Clamp (1) » Disengage — Hose Clamp Replacement Guidelines - Spring Type
92. Radiator Surge Tank Outlet Hose Clip (2) » Remove [2x]
93. Radiator Surge Tank Outlet Hose (3) » Position aside

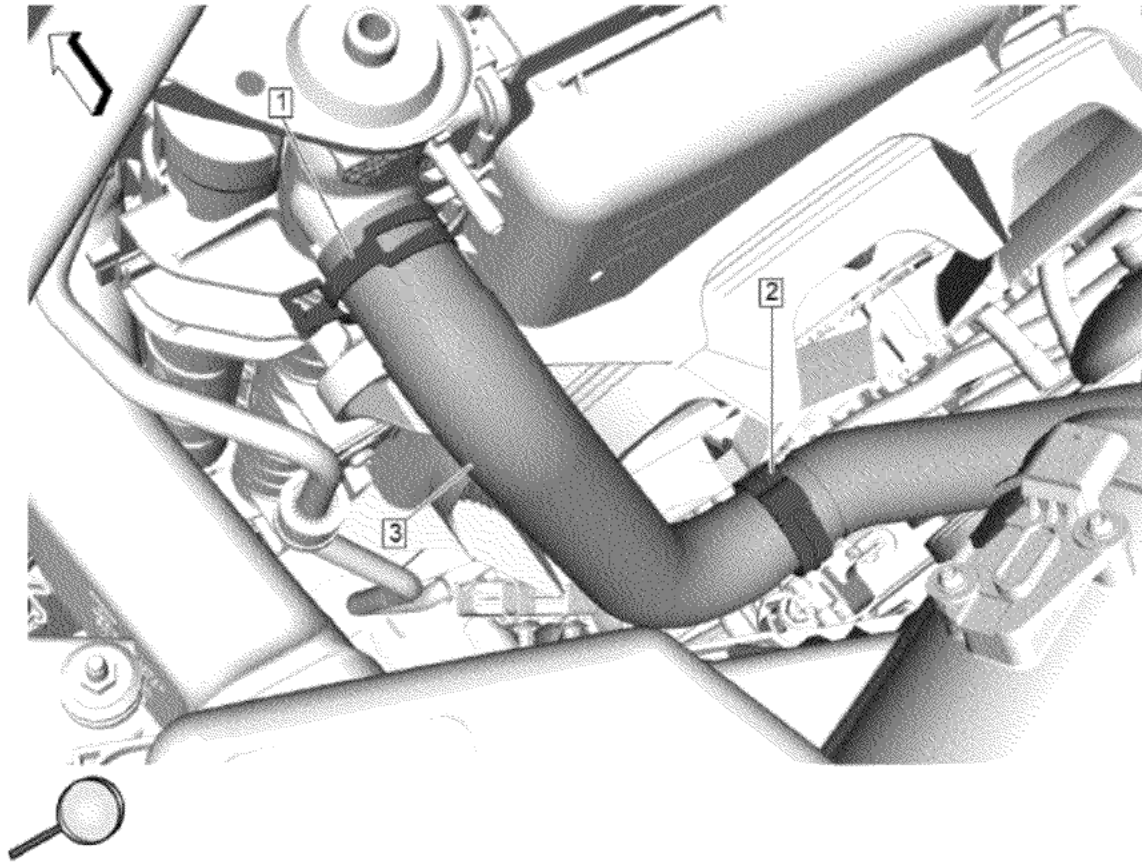

- 94. Radiator Inlet Hose Clip (2) » Remove
- 95. Radiator Inlet Hose Clamp (1) » Disengage — [Hose Clamp Replacement Guidelines - Spring Type](#)
- 96. Radiator Inlet Hose (3) @ Engine Radiator » Remove and position aside

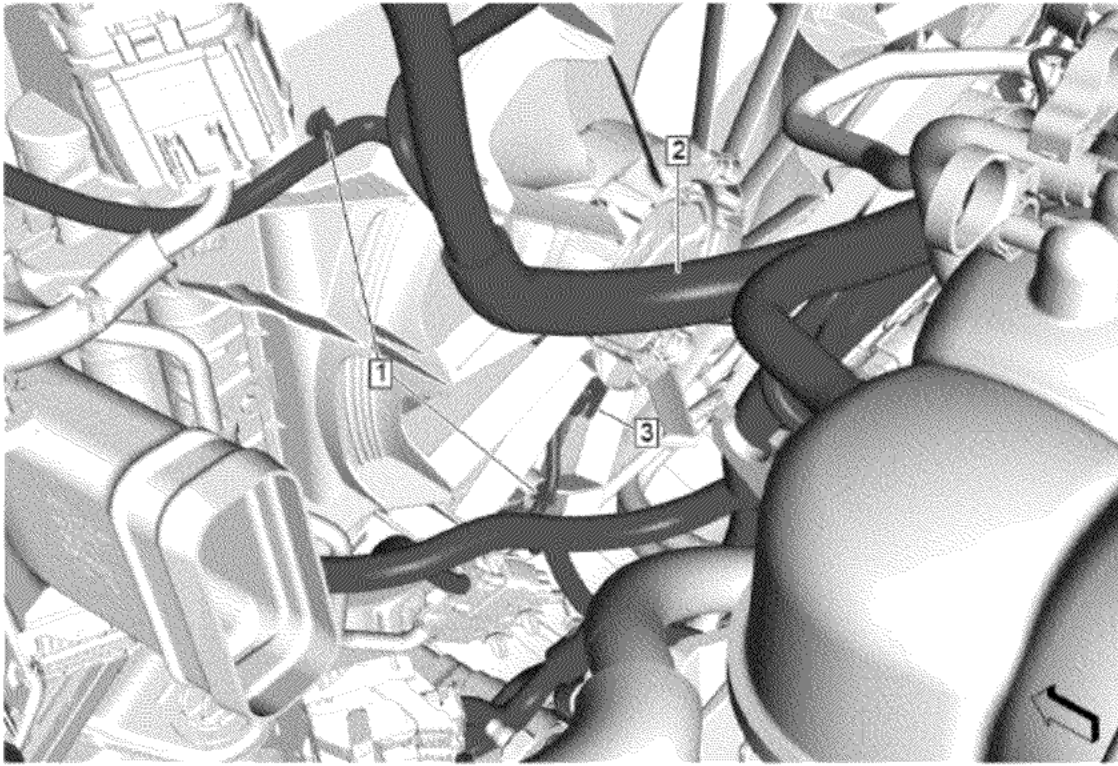

- 97. Wiring Harness Retainer (1) » Remove [2x]
- 98. Electrical Connector (3) » Disconnect
- 99. Wiring Harness (2) » Position aside

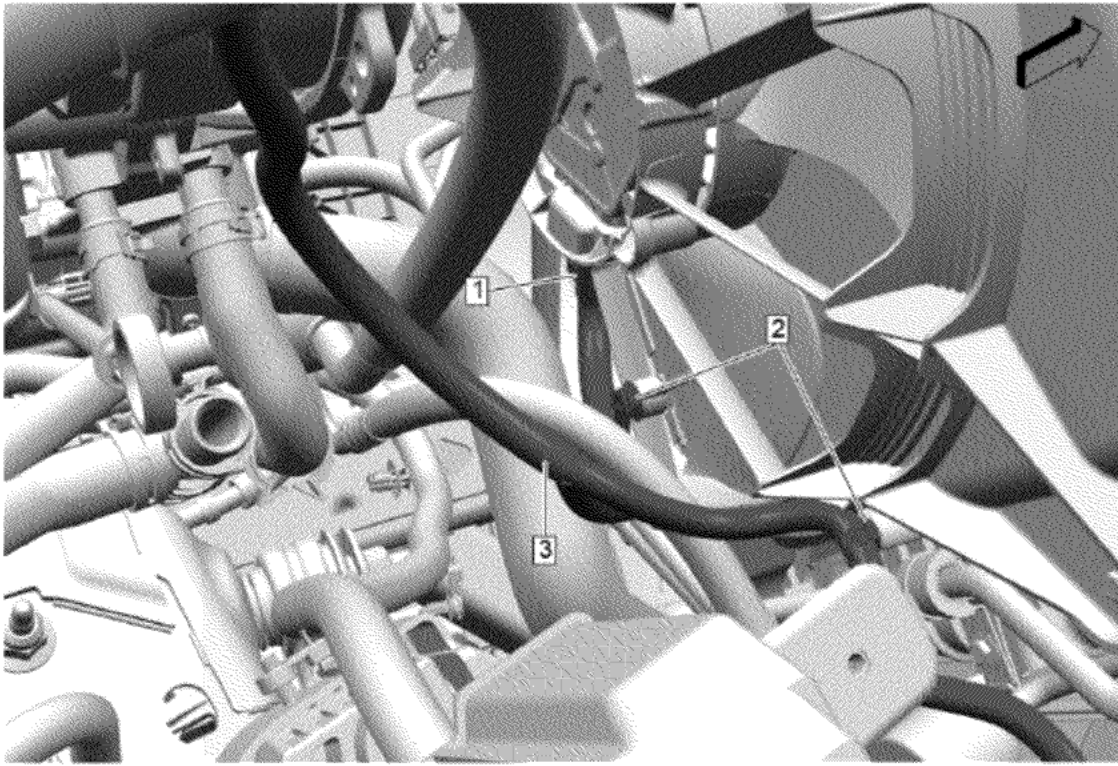

- 100. Wiring Harness Retainer (2) » Remove [2x]
- 101. Electrical Connector (1) » Disconnect
- 102. Wiring Harness (3) » Position aside

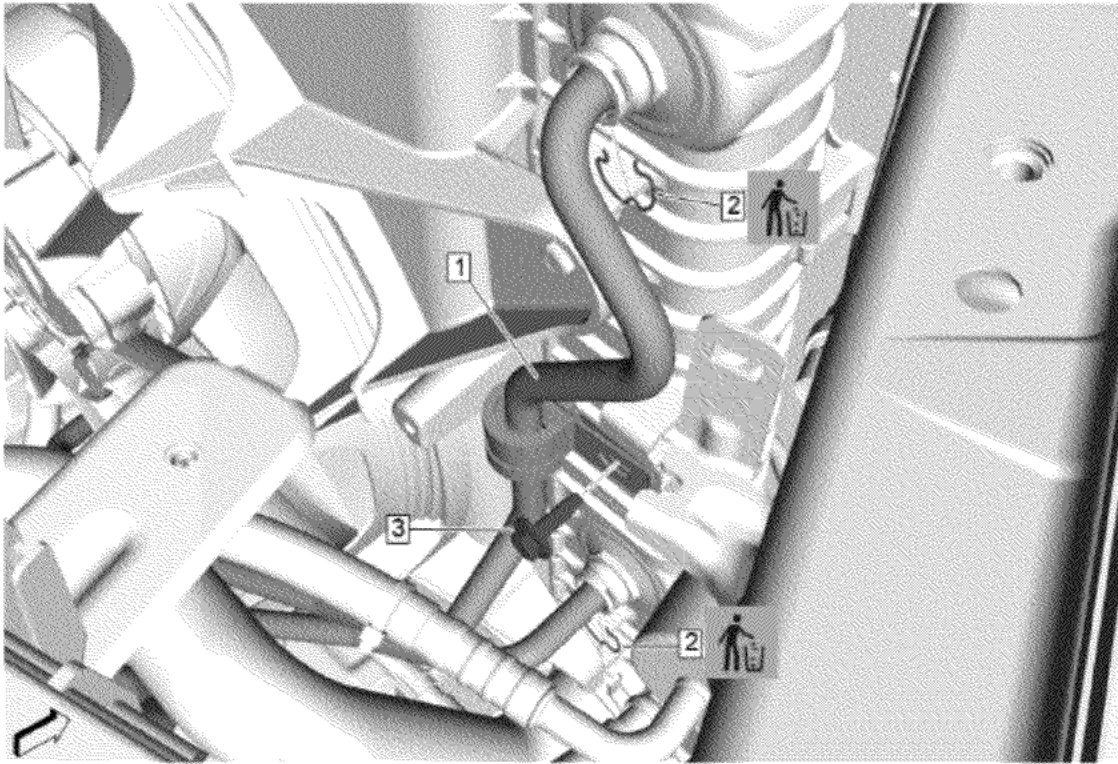

- 103. Engine Oil Cooler Retainer (2) » Remove and DISCARD [2x]
- 104. Engine Oil Cooler Pipe Bracket Bolt (3) » Remove
- 105. Engine Oil Cooler Hose (1) @ Engine Radiator » Remove [2x]

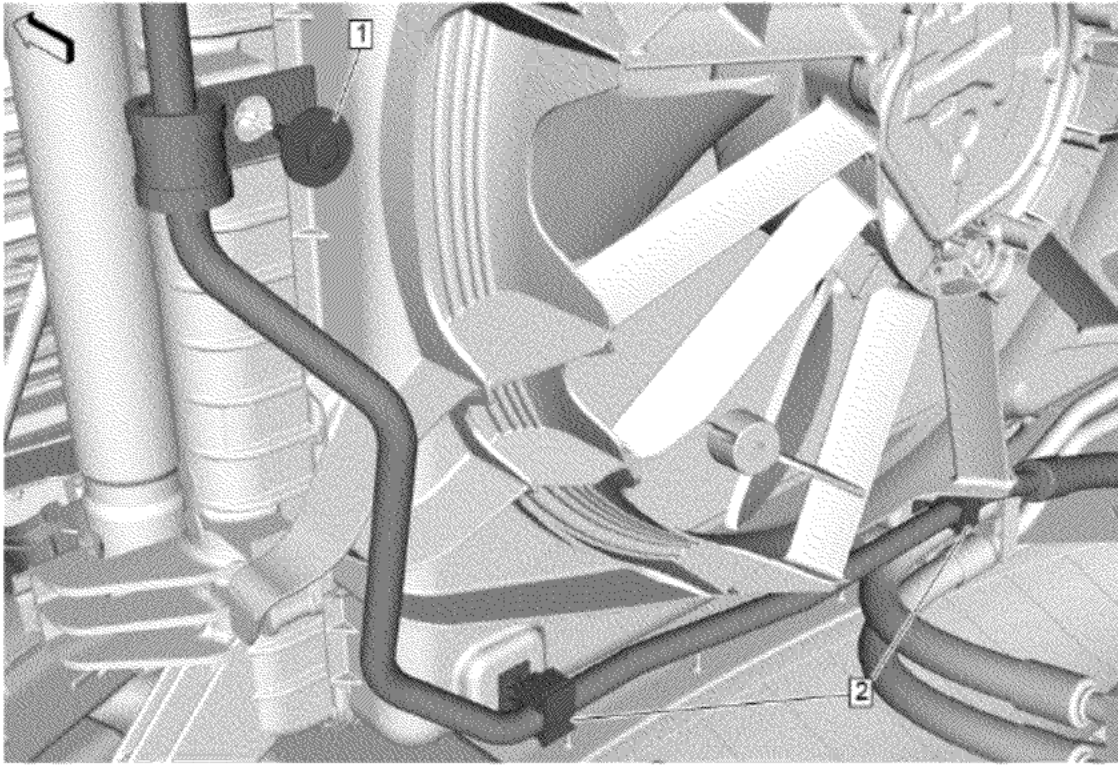

106. Transmission Fluid Cooler Pipe Bolt (1) » Remove

107. Transmission Fluid Cooler Pipe Clip (2) » Remove [2x]

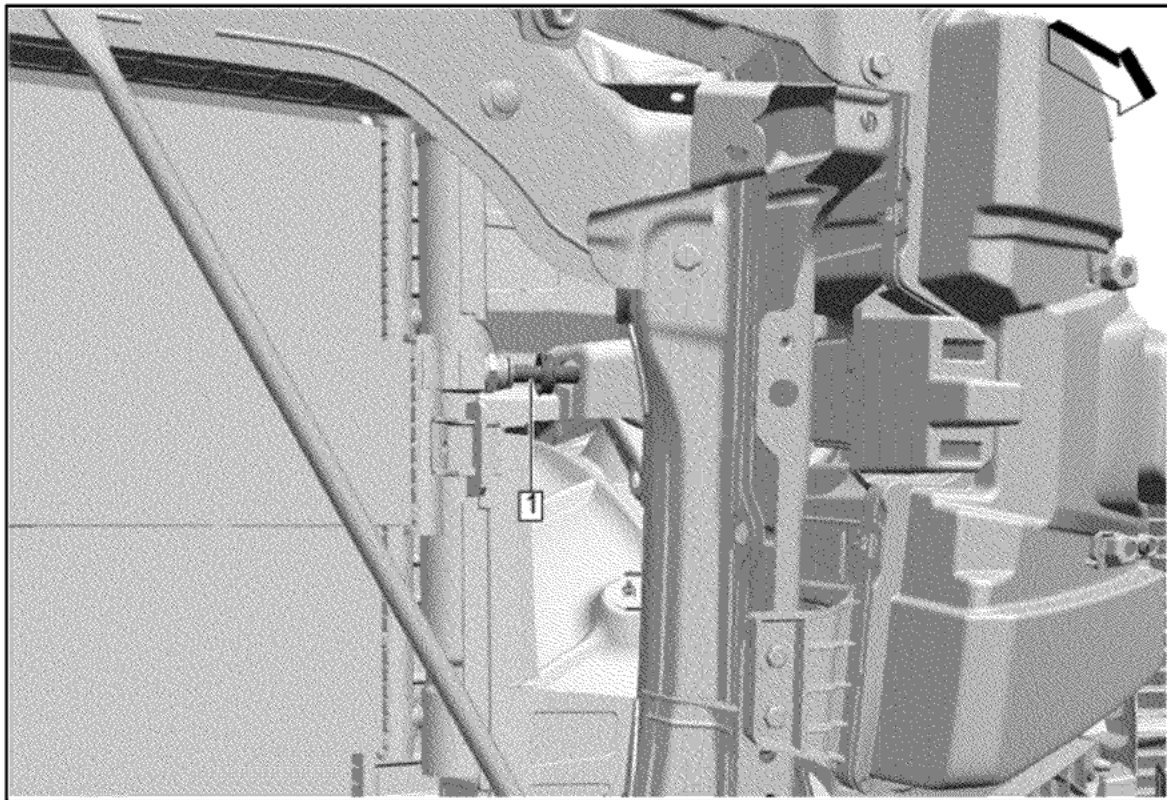

108. Transmission Fluid Cooler Inlet and Outlet Pipe (1) @ Transmission Fluid Auxiliary Cooler »
Remove — Transmission Fluid Cooler Hose/Pipe Quick-Connect Fitting Disconnection and Connection

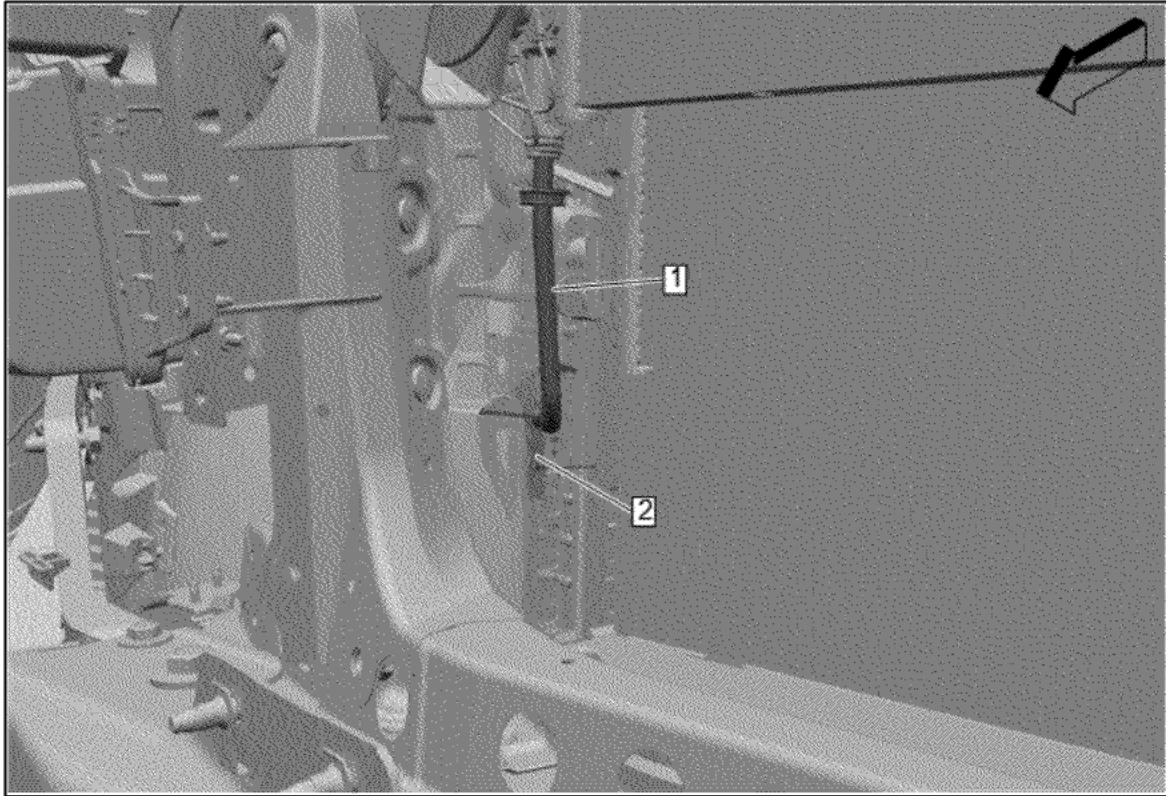

© 2025 General Motors. All rights reserved.

109. Transmission Fluid Cooler Inlet and Outlet Pipe Bolt (2) @ Radiator » Remove
110. Transmission Fluid Cooler Inlet and Outlet Pipe (1) @ Transmission Fluid Auxiliary Cooler »
Remove — Transmission Fluid Cooler Hose/Pipe Quick-Connect Fitting Disconnection and Connection

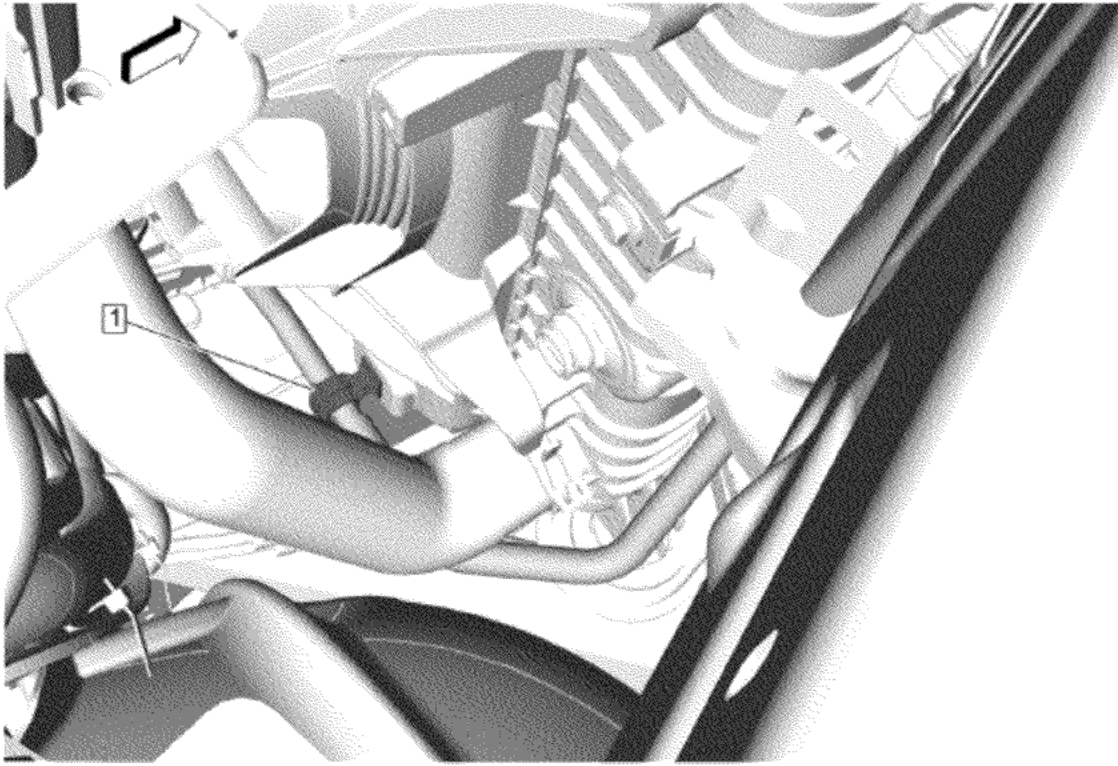

111. Transmission Fluid Cooler Pipe Clip (1) » Release

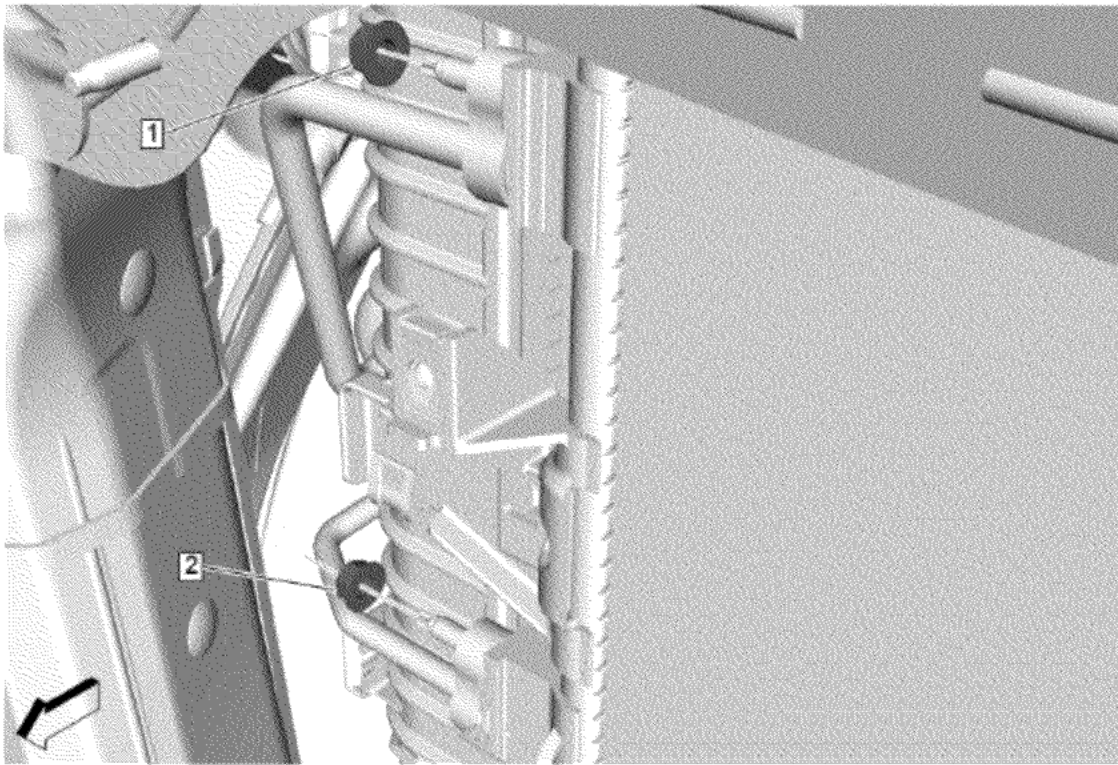

112. Air Conditioning Compressor and Condenser Hose Nut (1) » Remove

113. Air Conditioning Condenser and Evaporator Hose Nut (2) » Remove

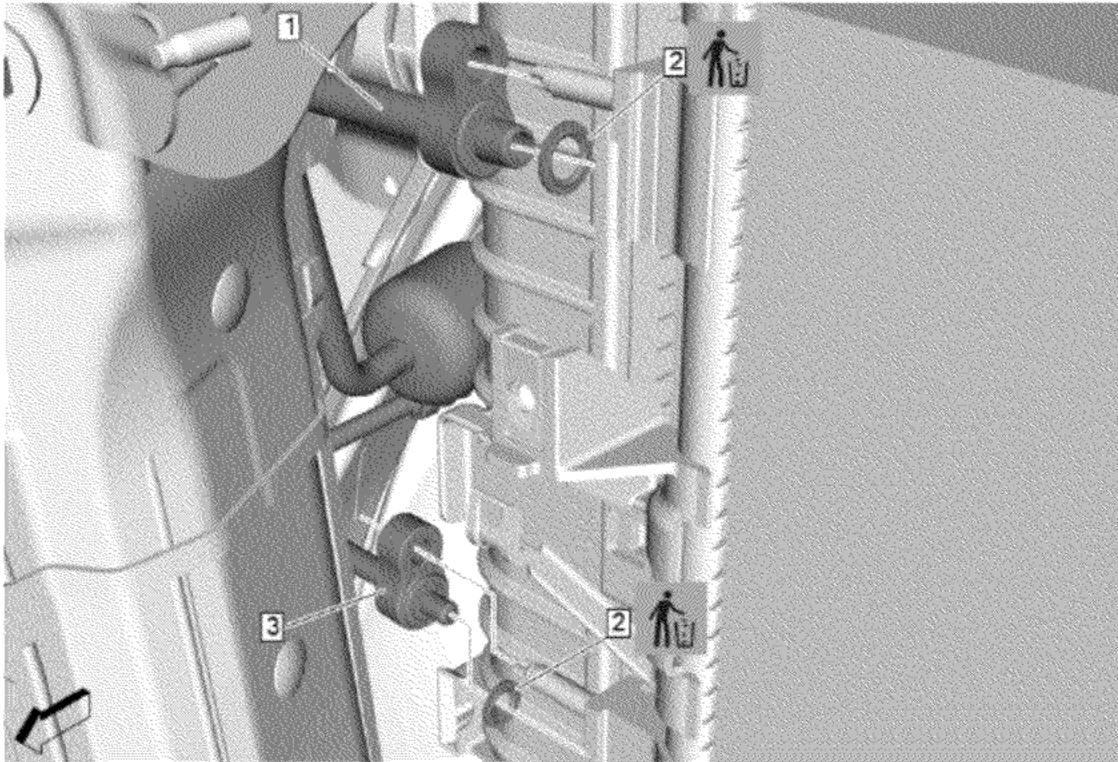

© 2025 General Motors. All rights reserved.

114. Air Conditioning Compressor and Condenser Hose (1) @ Air Conditioning Condenser » Remove

115. Air Conditioning Condenser and Evaporator Hose (3) @ Air Conditioning Condenser » Remove

116. Air Conditioning Compressor and Condenser Hose Seal (2) » Remove and DISCARD [2x]

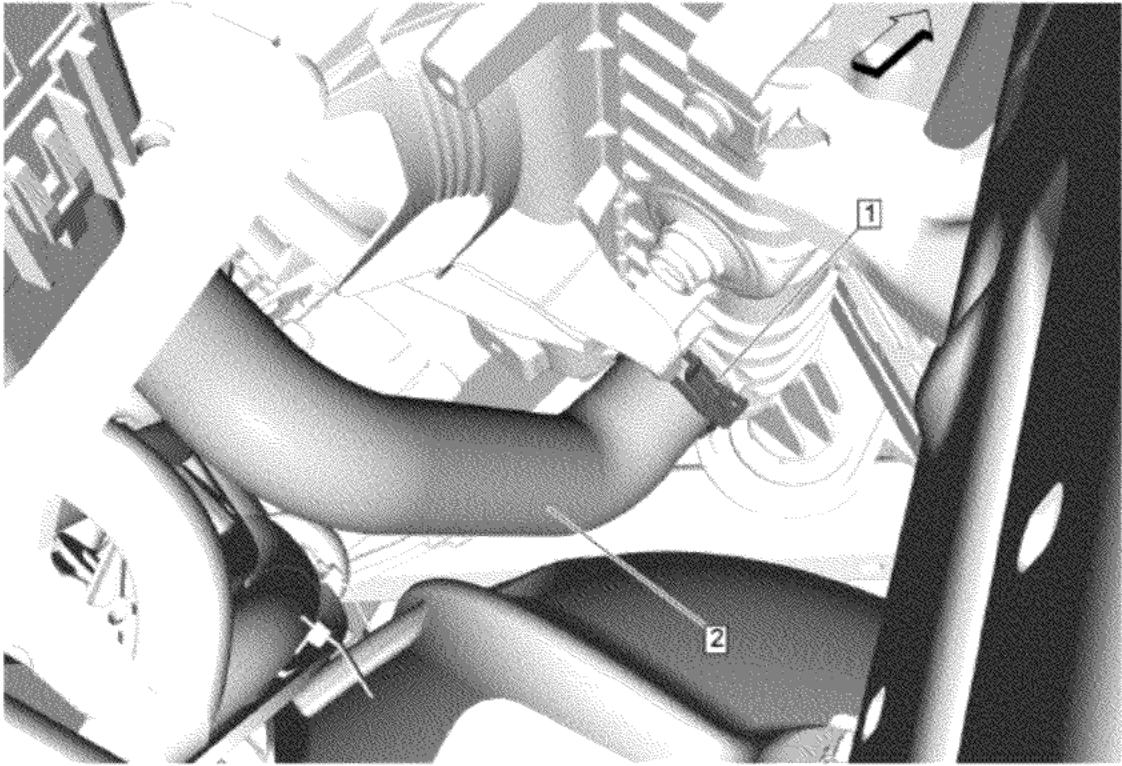

- 117. Radiator Inlet Hose Clamp (1) » Disengage — [Hose Clamp Replacement Guidelines - Spring Type](#)
- 118. Radiator Outlet Hose (2) @ Engine Radiator » Remove

© 2025 General Motors. All rights reserved.

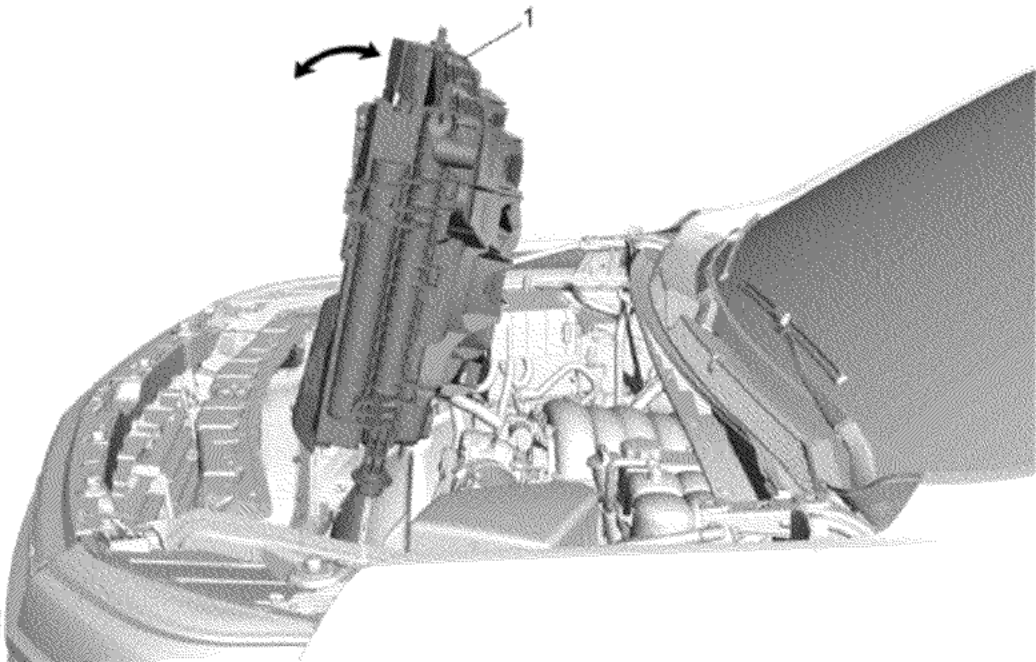

119. Rotate the top of the condenser, fan and radiator assembly (1) rearward and lift it out of the engine compartment.

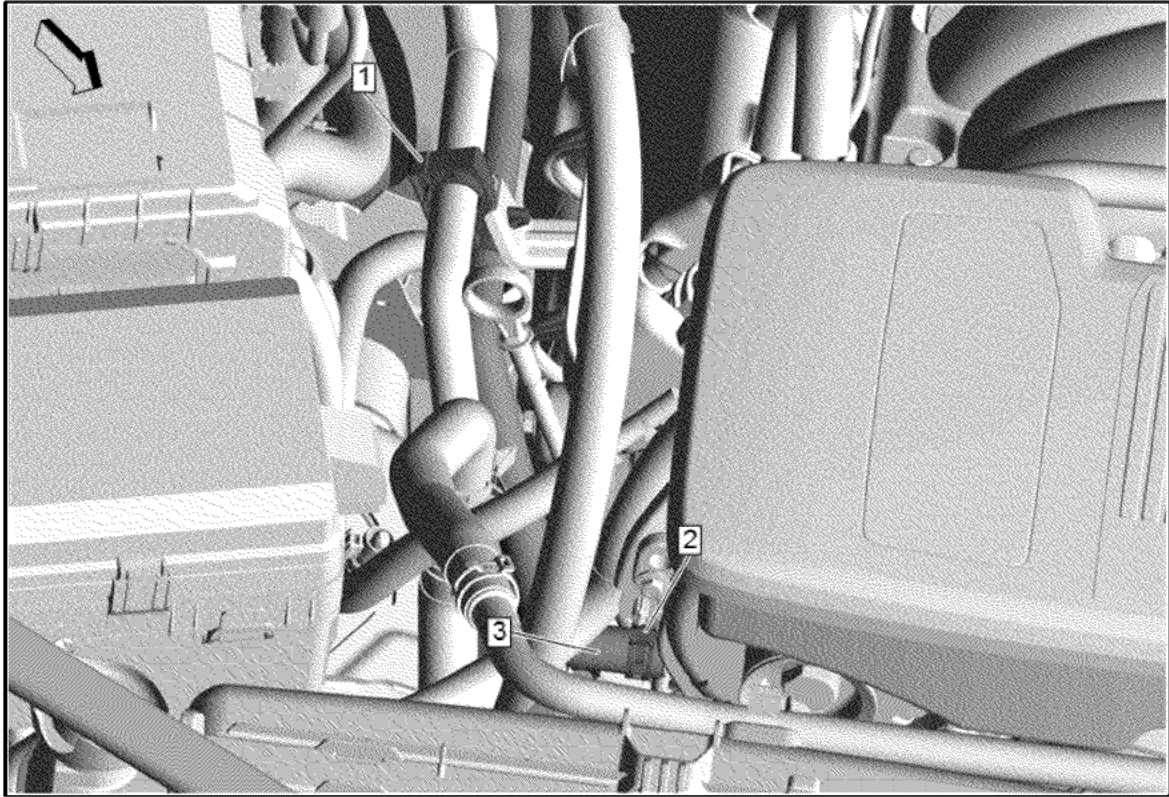

© 2025 General Motors. All rights reserved.



120. Heater Inlet Hose (3) @ Heater Inlet and Outlet Hose Clip (1) » Remove

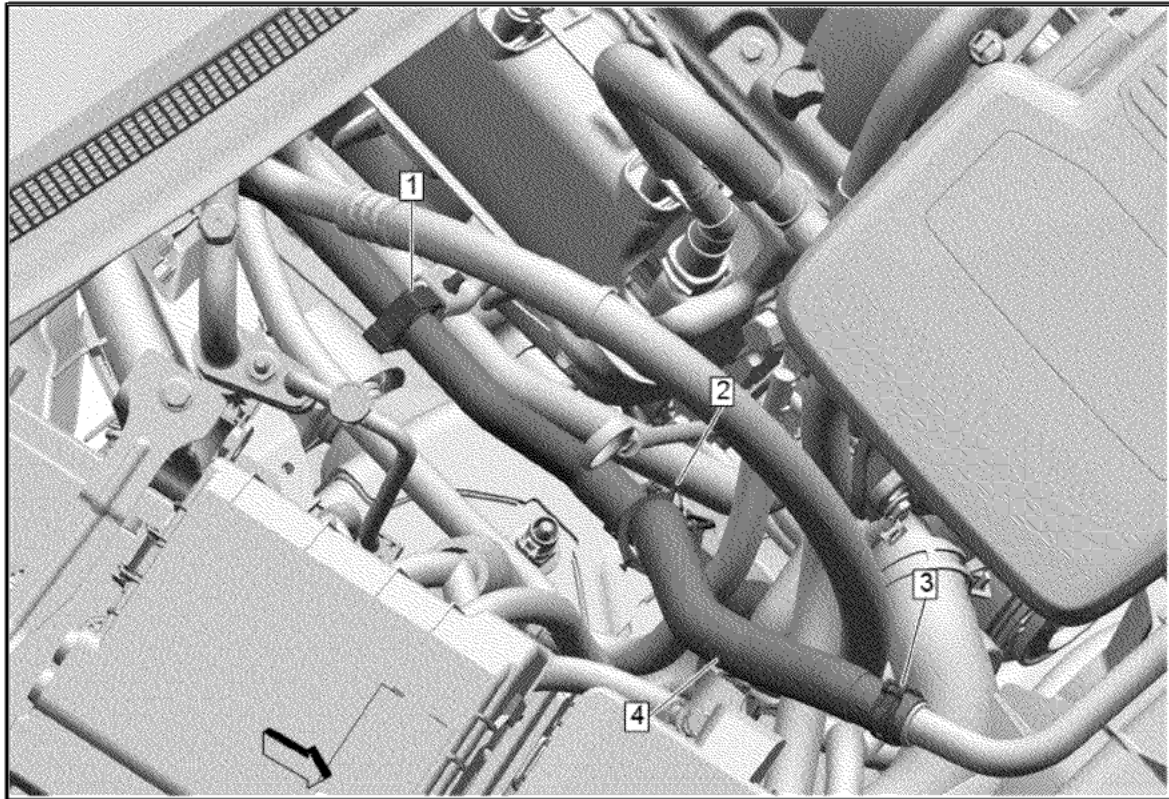

© 2025 General Motors. All rights reserved.

- 121. Engine Wiring Harness Clip (2) @ Heater Outlet Hose » Remove
- 122. Heater Outlet Hose (4) @ Clip (1) » Remove
- 123. Heater Outlet Hose Clamp (3) » Disengage — [Hose Clamp Replacement Guidelines - Spring Type](#)
- 124. Heater Outlet Hose (4) @ Radiator Surge Tank Outlet Hose » Remove

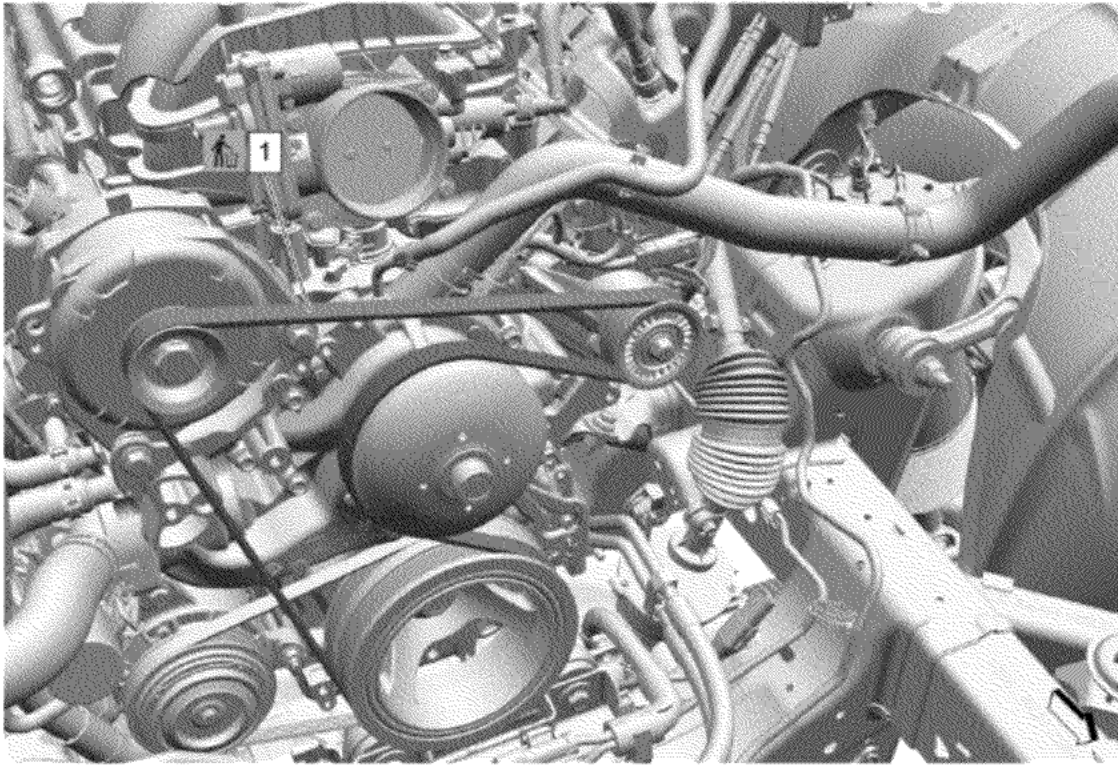

- Note:** The accessory drive primary belt is not reusable.
125. Using a suitable tool, cut the accessory drive primary belt (1).
 126. Accessory Drive Primary Belt (1) » Remove and DISCARD

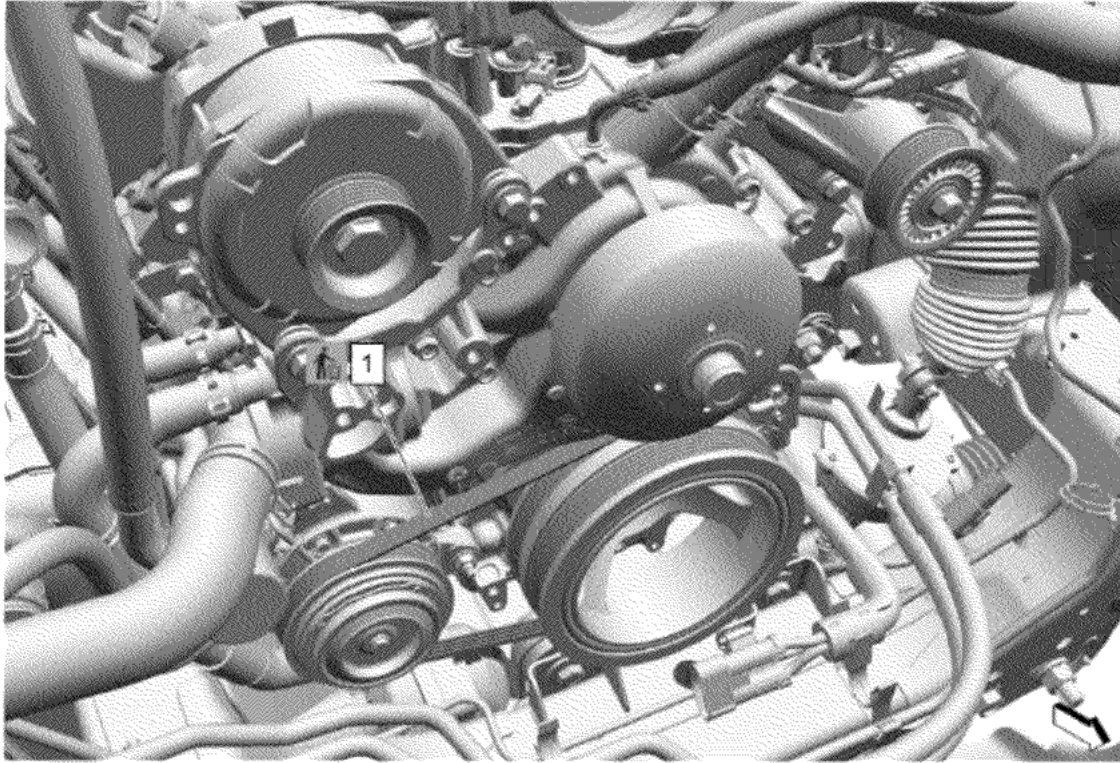

- Note:** The accessory drive auxiliary belt is not reusable.
127. Using a suitable tool, cut the accessory drive auxiliary belt (1).
 128. Accessory Drive Auxiliary Belt (1) » Remove and DISCARD

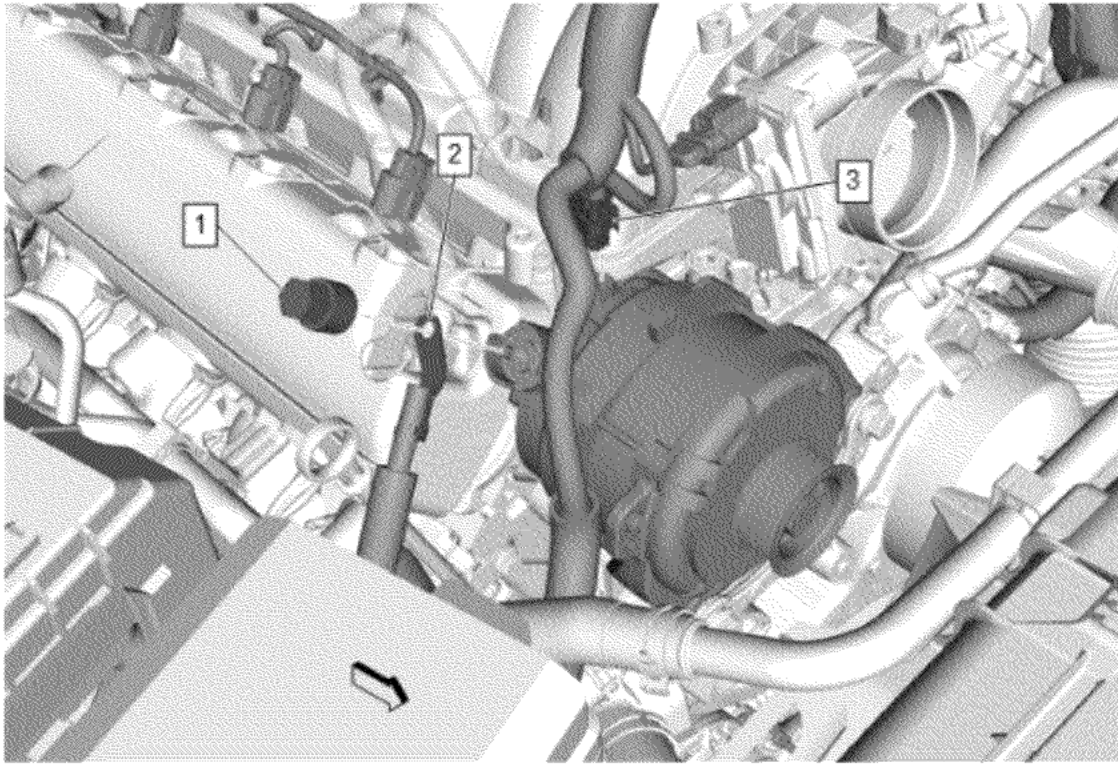

- 129. Battery Positive Cable Nut (1) » Remove
- 130. Starter Solenoid Cable (2) » Remove
- 131. Electrical Connector (3) » Disconnect

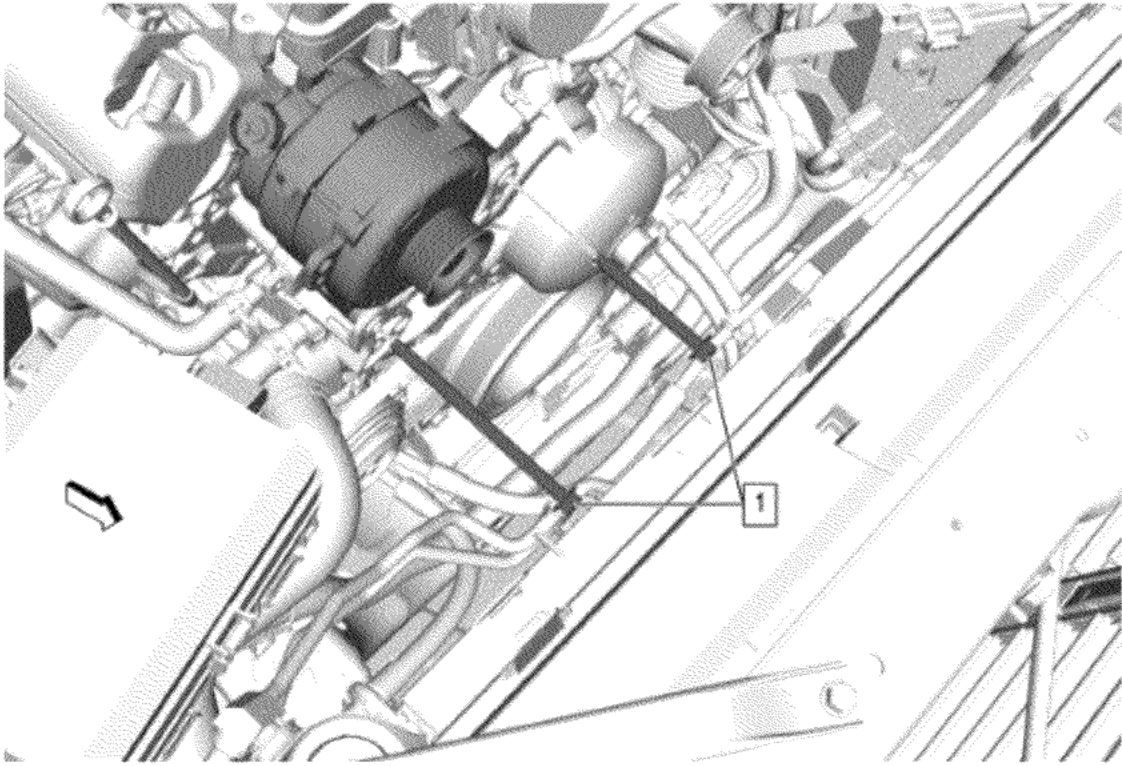

132. Generator Bolt (1) » Remove [2x]

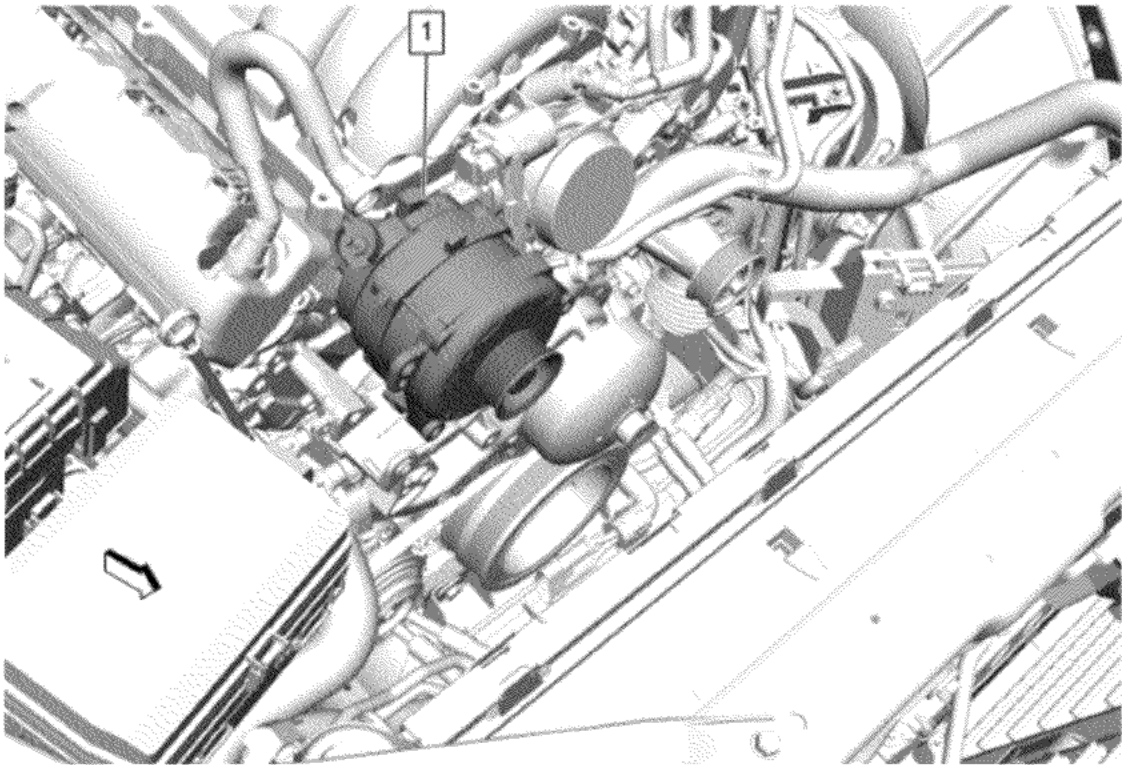

133. Generator (1) » Remove

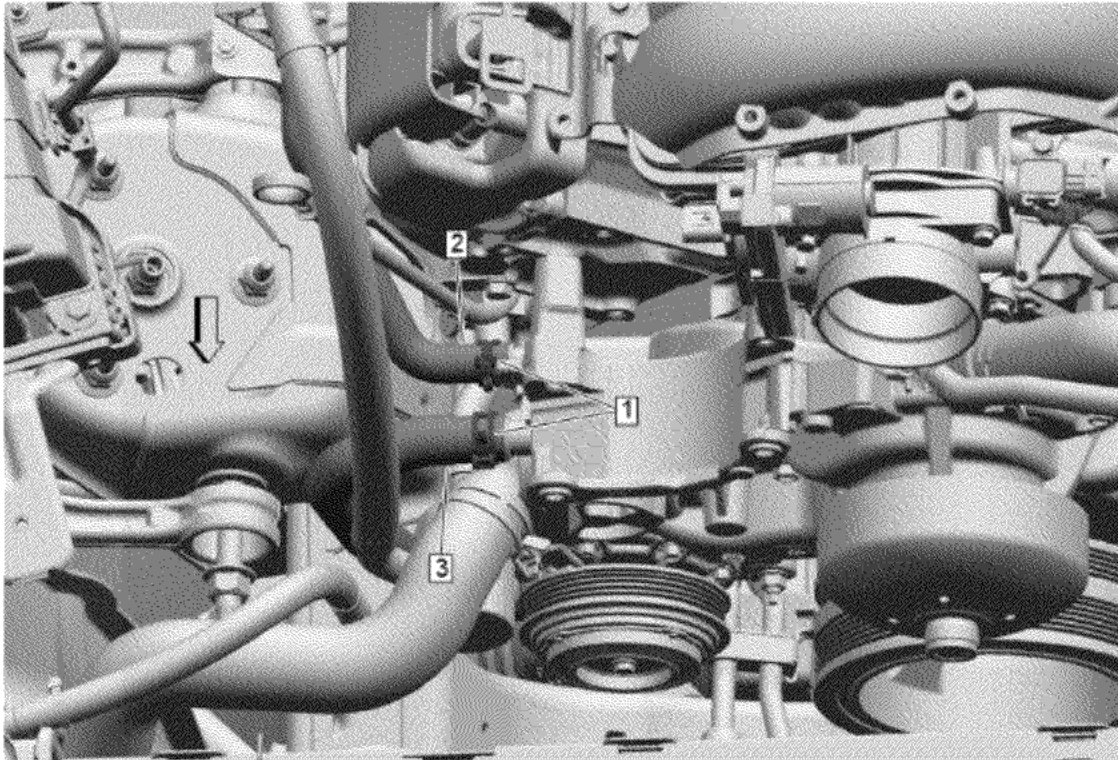

© 2025 General Motors. All rights reserved.

134. Hose Clamp (1) » Disengage [2x] — [Hose Clamp Replacement Guidelines - Spring Type](#)
135. Heater Inlet Hose (2) @ Water Pump » Remove
136. Heater Water Auxiliary Pump Hose (3) @ Water Pump » Remove

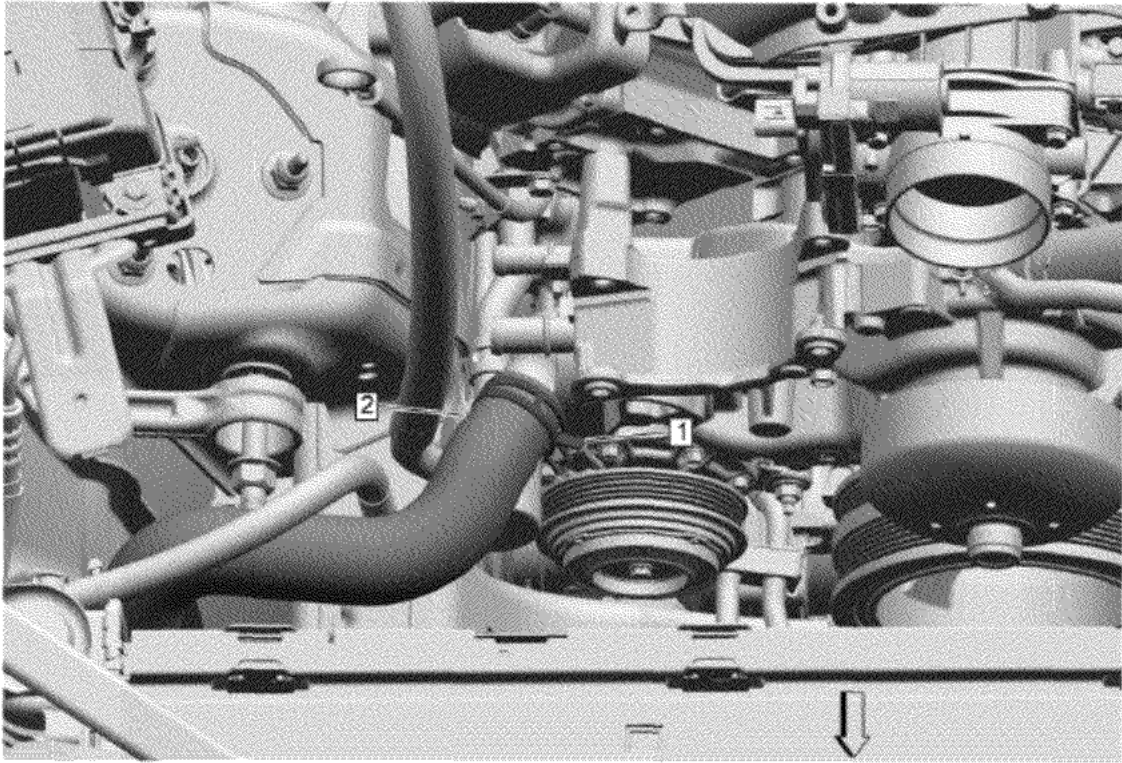

137. Radiator Outlet Hose Clamp (1) » Disengage — [Hose Clamp Replacement Guidelines - Spring Type](#)

138. Radiator Outlet Hose (2) @ Water Pump » Remove

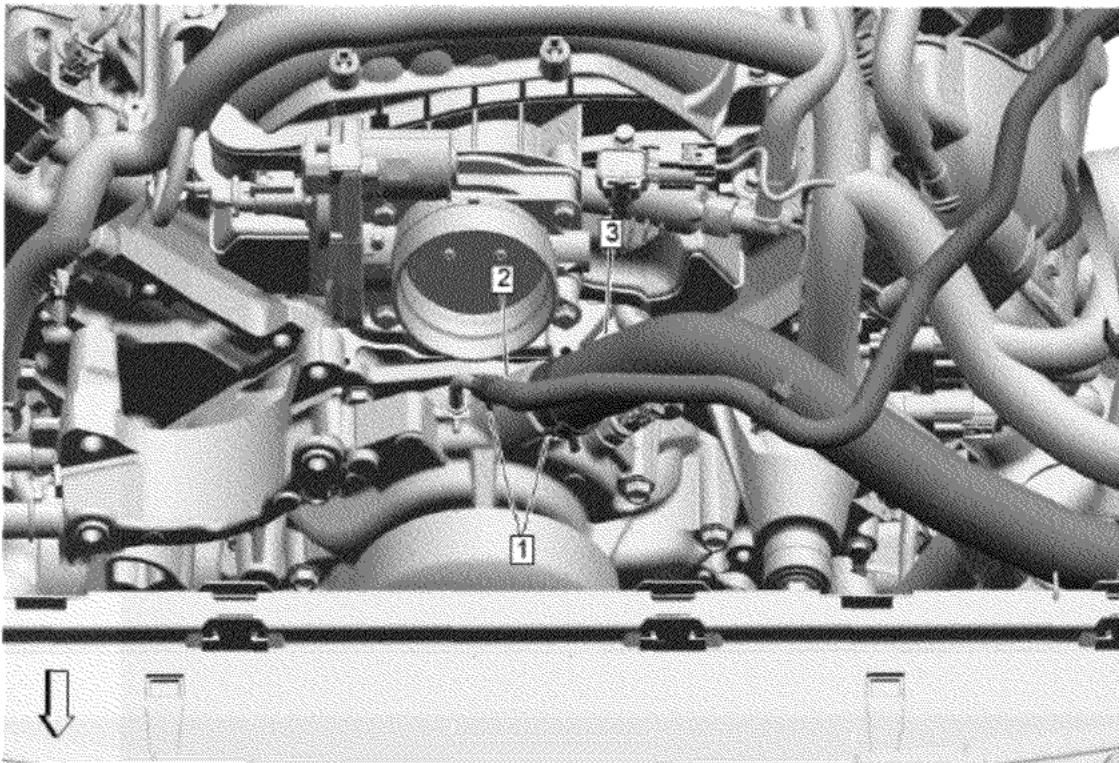

139. Hose Clamp (1) » Disengage [2x] — [Hose Clamp Replacement Guidelines - Spring Type](#)

140. Engine Coolant Air Bleed Hose (2) @ Water Pump » Remove

141. Radiator Inlet Hose (3) @ Water Pump » Remove

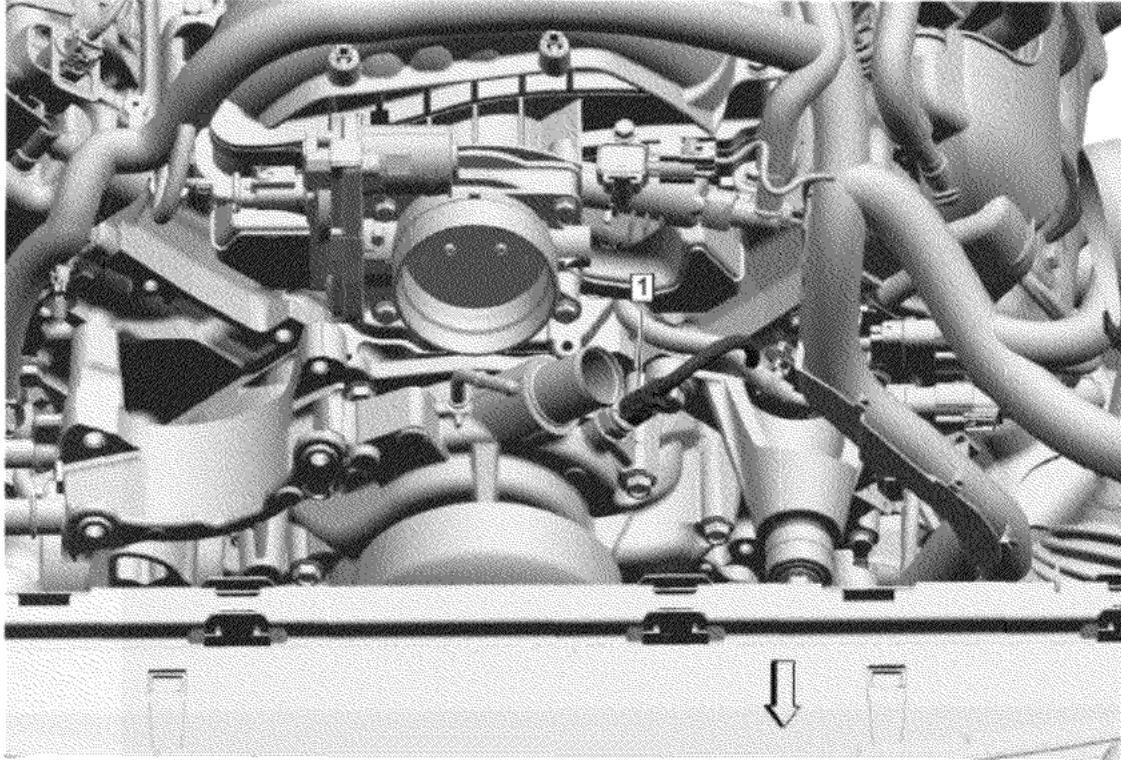

© 2025 General Motors. All rights reserved.

142. Engine Coolant Temperature Sensor Electrical Connector (1) » Disconnect

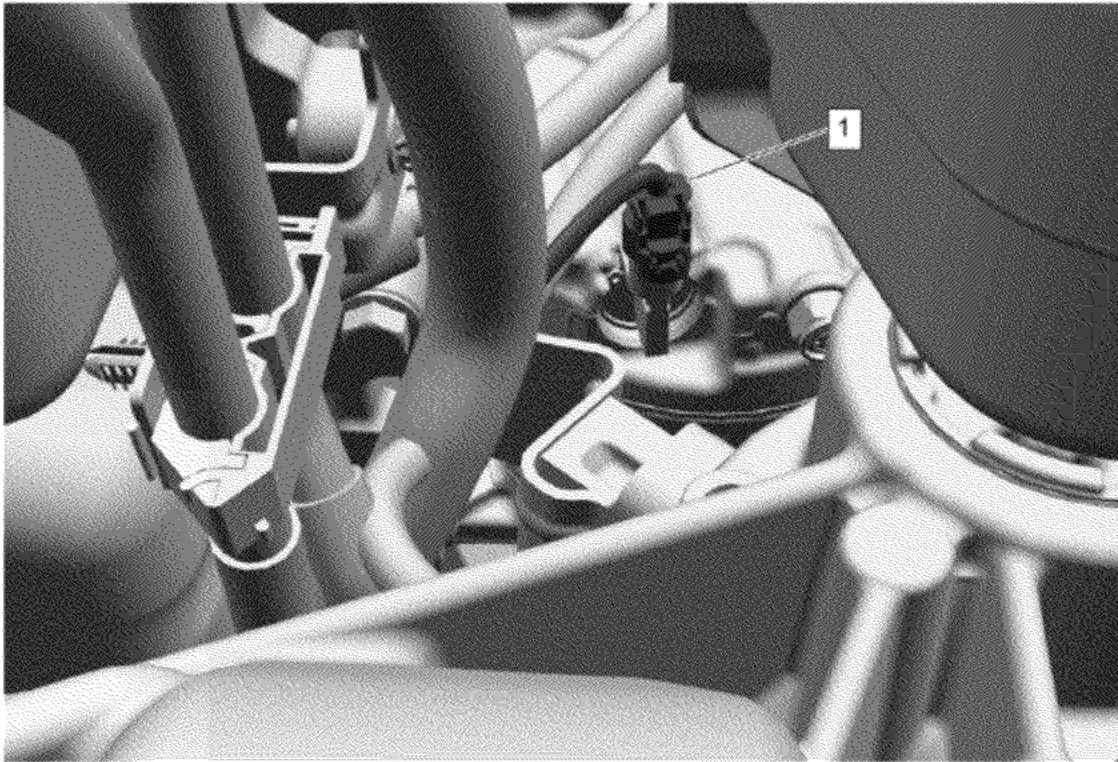

143. Electrical Connector (1) @ Air Conditioning Compressor » Disconnect

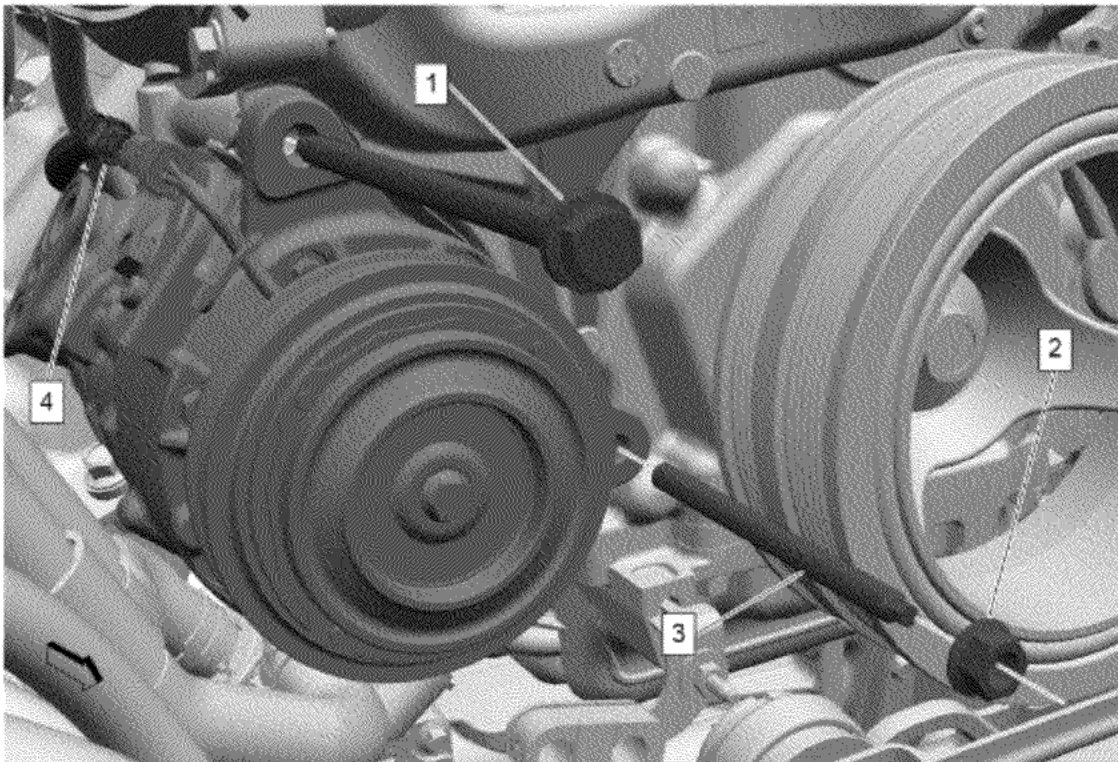

144. Air Conditioning Compressor Bolt (1) » Remove

145. Air Conditioning Compressor Nut (2) » Remove

146. Air Conditioning Compressor Stud (3) » Remove

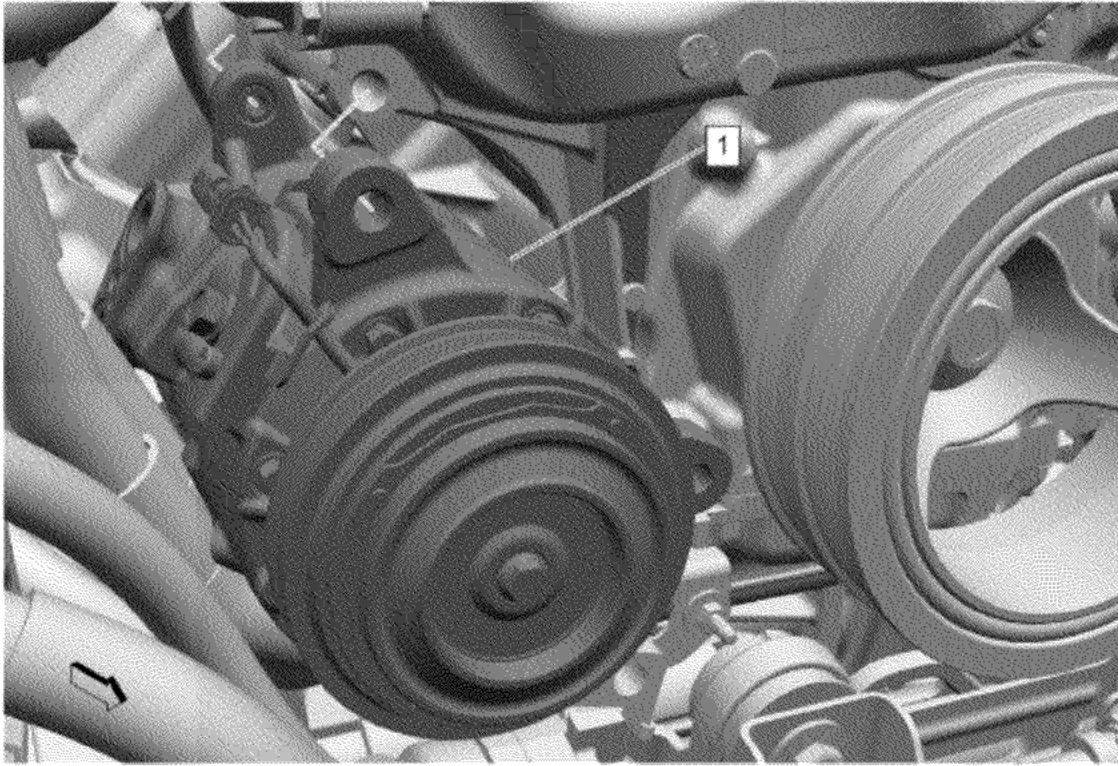

147. Air Conditioning Compressor (1) » Position aside

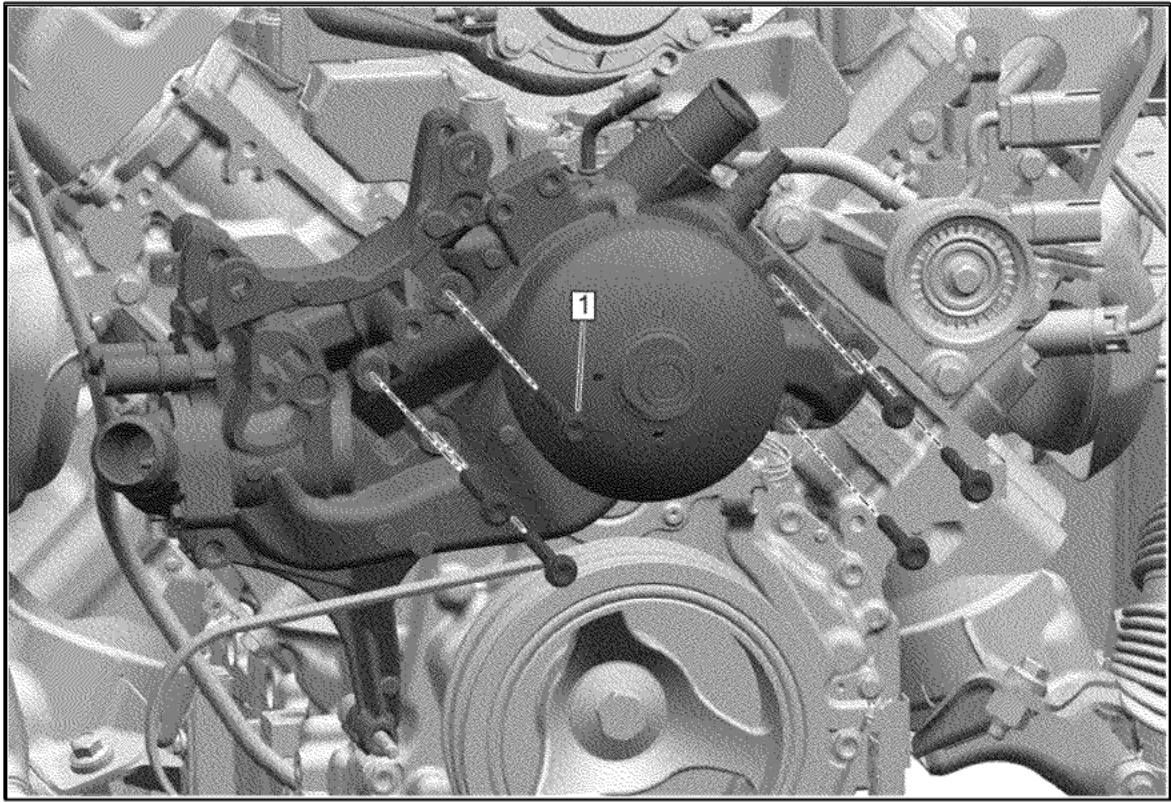

148. Water Pump Housing Bolt (1) » Remove [6x]

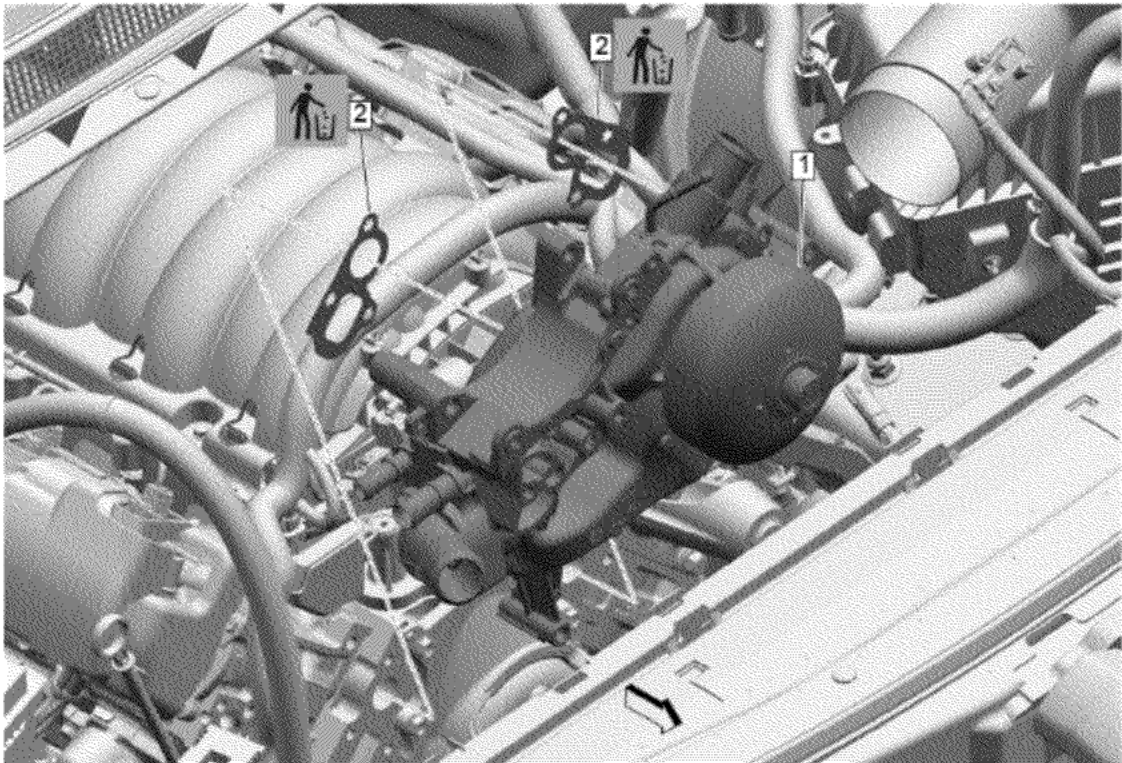

149. Water Pump (1) » Remove

150. Water Pump Gasket (2) » Remove and DISCARD [2x]

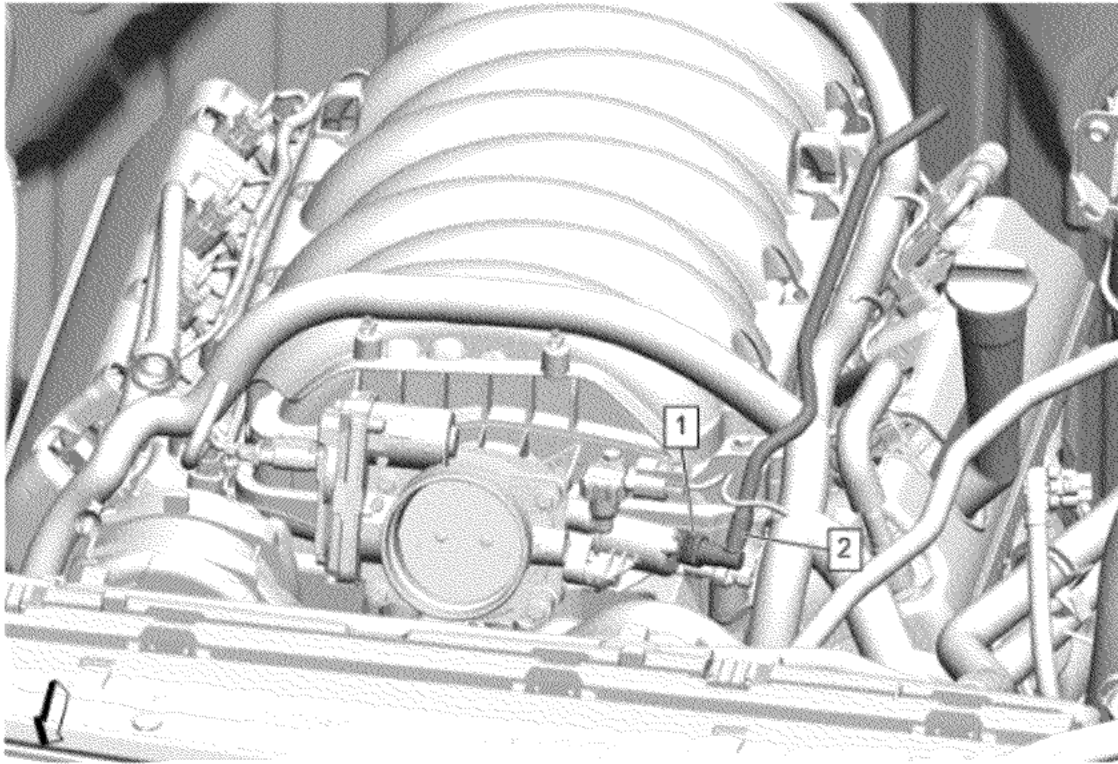

151. Evaporative Emission Canister Purge Tube Connector (1) @ Evaporative Emission Canister Purge Solenoid Valve » Disengage — Plastic Collar Quick Connect Fitting Service

152. Evaporative Emission Canister Purge Tube (2) @ Evaporative Emission Canister Purge Solenoid Valve » Remove and position aside

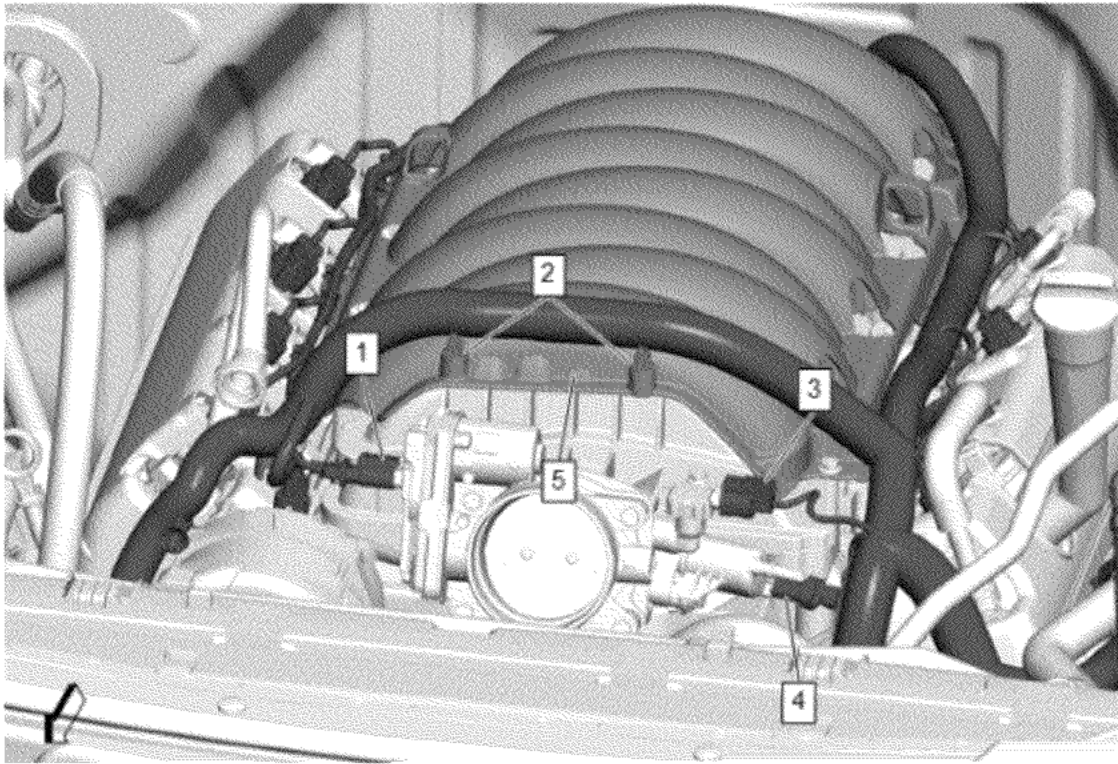

- 153. Engine Wiring Harness Connector (1) @ Throttle Body » Disconnect
- 154. Engine Wiring Harness Retainer (2) @ Intake Manifold Cover » Remove [2x]
- 155. Engine Wiring Harness Connector (3) @ Manifold Absolute Pressure Sensor » Disconnect
- 156. Engine Wiring Harness Connector (4) @ Evaporative Emission Canister Purge Solenoid Valve » Disconnect

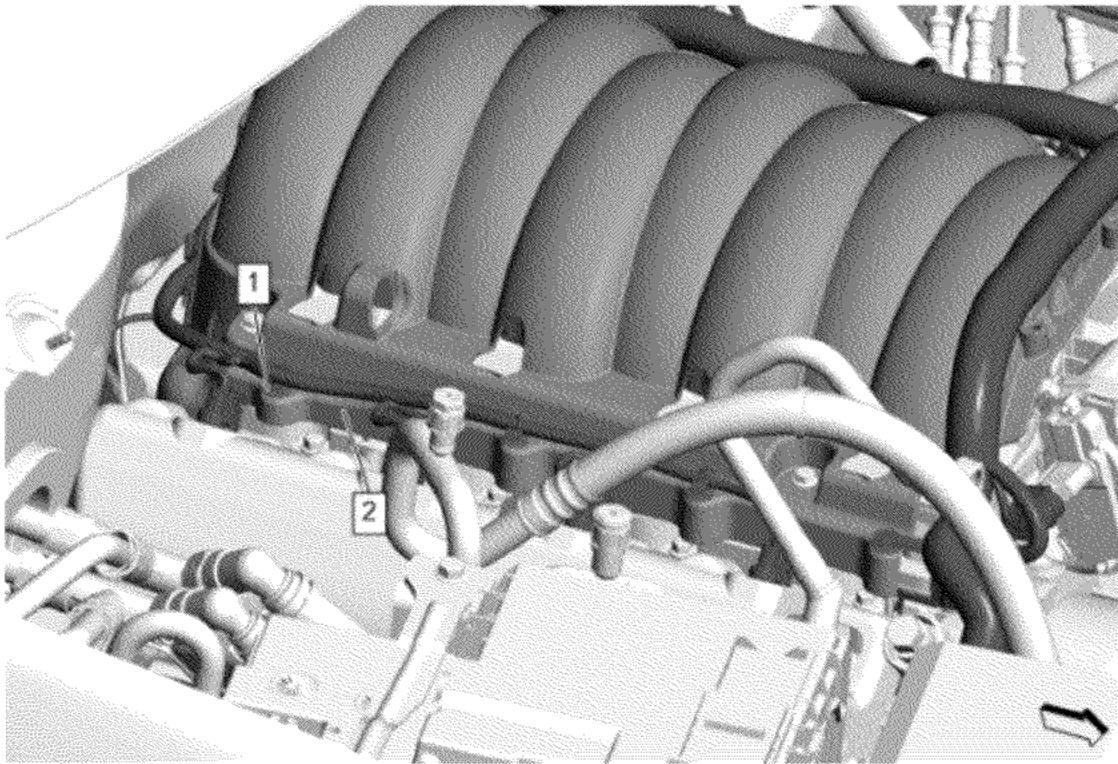

157. Engine Wiring Harness Retainer (1) @ Intake Manifold Cover (2) » Remove [4x]

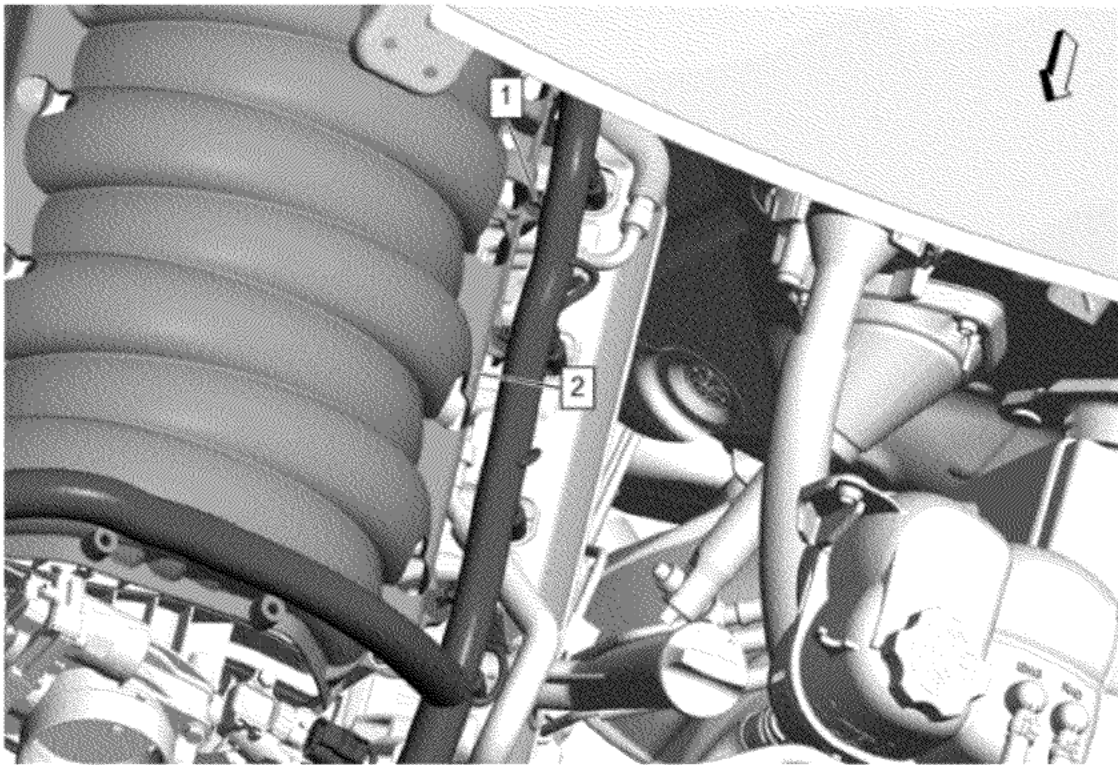

158. Engine Wiring Harness Retainer (1) @ Intake Manifold Cover (2) » Remove [3x]

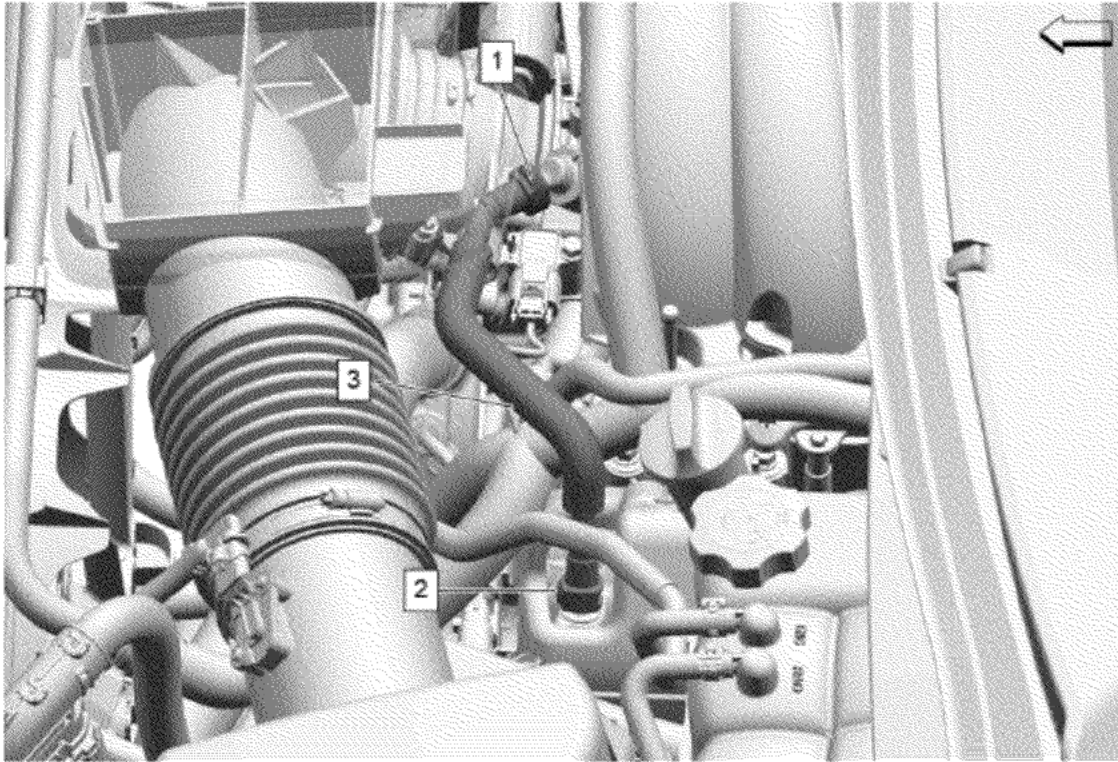

159. Positive Crankcase Ventilation Tube Connector (1) @ Intake Manifold > Disconnect and reposition — [Plastic Collar Quick Connect Fitting Service](#)

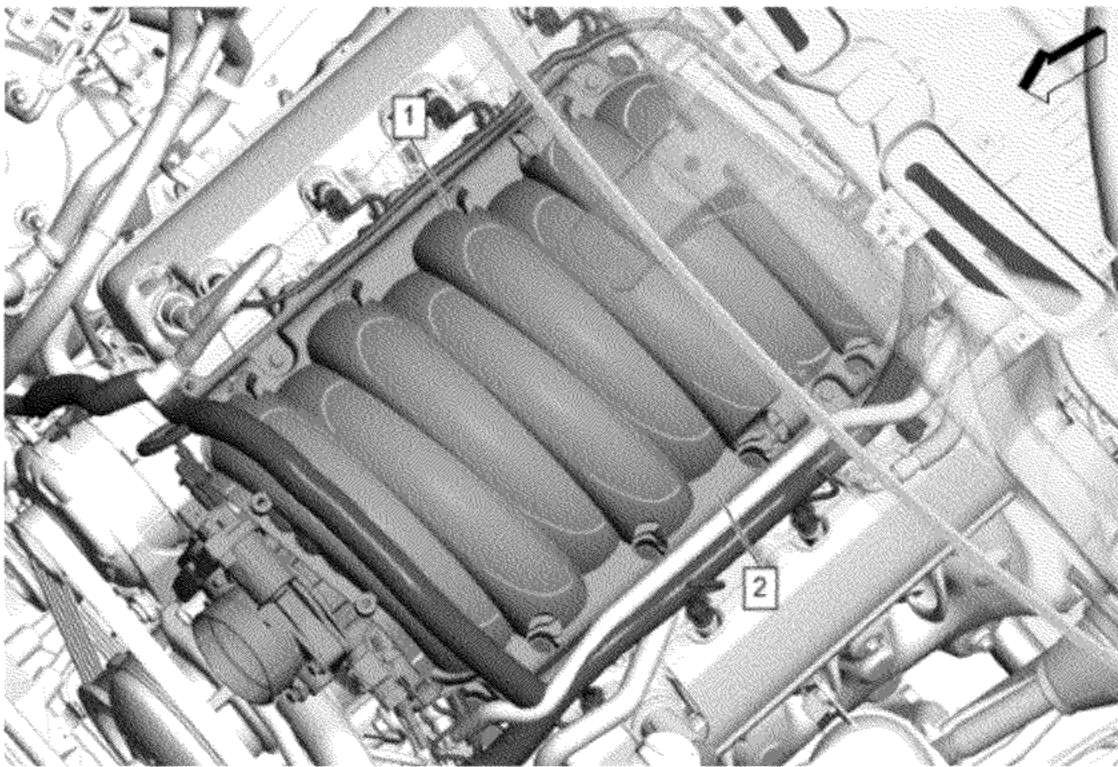

Note: Some components not shown for graphic clarity.

160. Loosen the 10 intake manifold bolts (1) until the bolts are no longer threaded into the cylinder heads.

161. Move the intake manifold and intake manifold cover (2) forward enough to gain access to the rear engine wiring harness retainers.

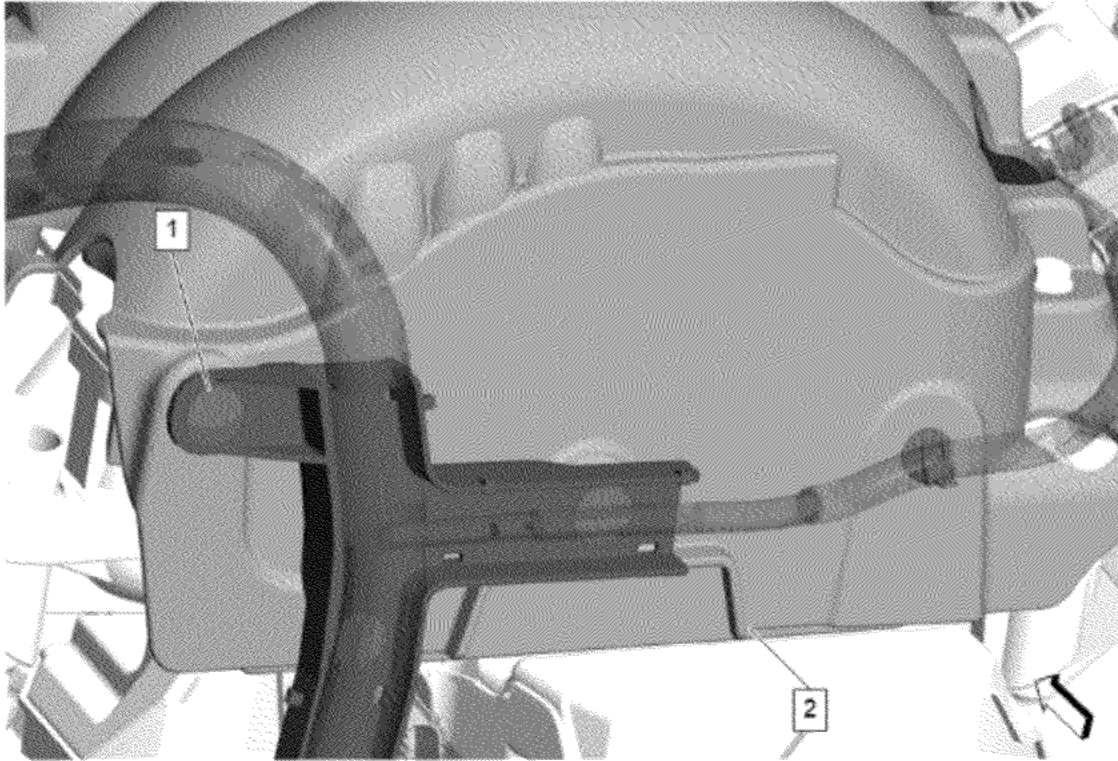

162. Engine Wiring Harness Retainer (1) @ Intake Manifold Cover (2) » Remove [4x]

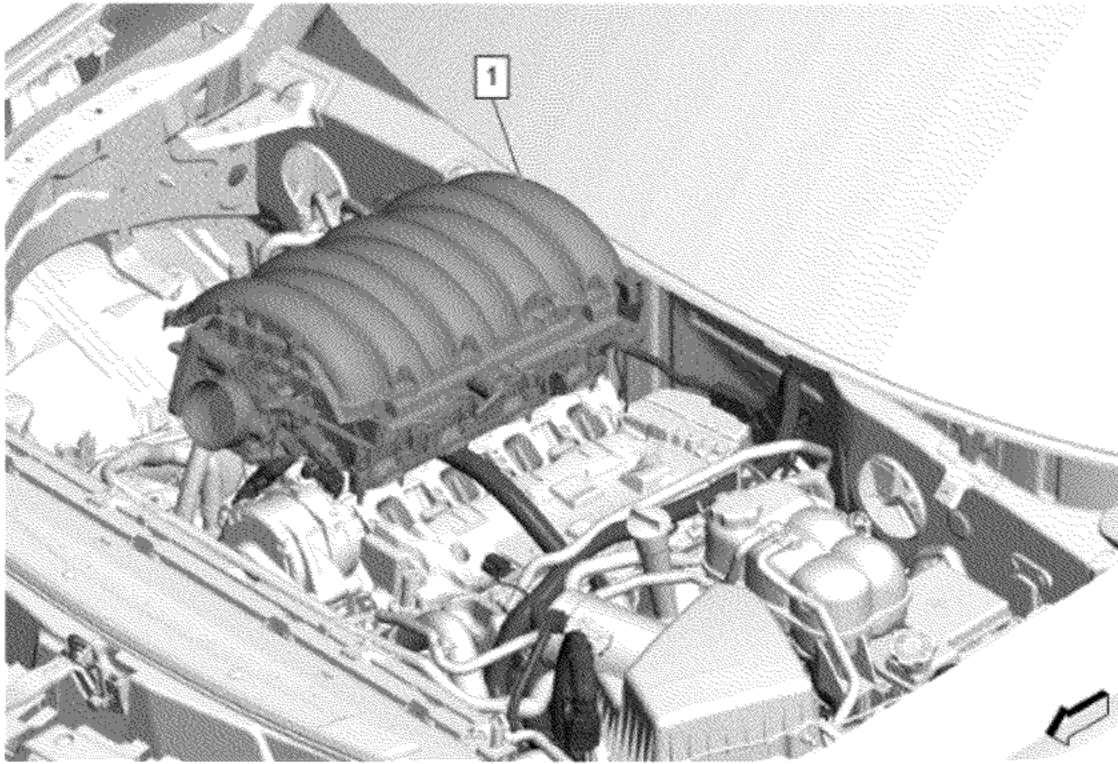

Note: The aid of an assistant may be helpful in holding the engine harness up out of the way so the upper intake manifold cover does not get caught against the engine harness.

163. Remove the intake manifold and intake manifold cover (1) as an assembly.

164. Cover the cylinder head passages in order to prevent dirt or debris from entering the passages.

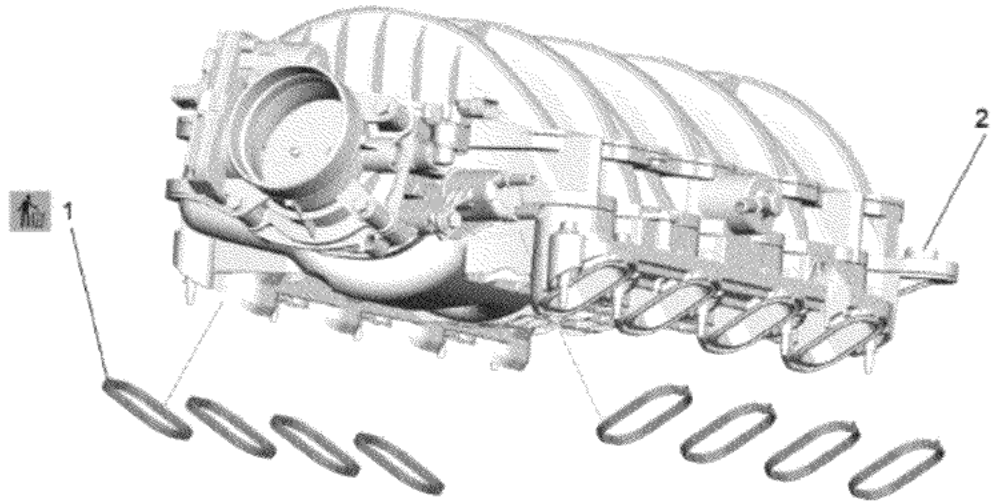

165. Intake Manifold Gasket (1) » Remove and DISCARD [8x]

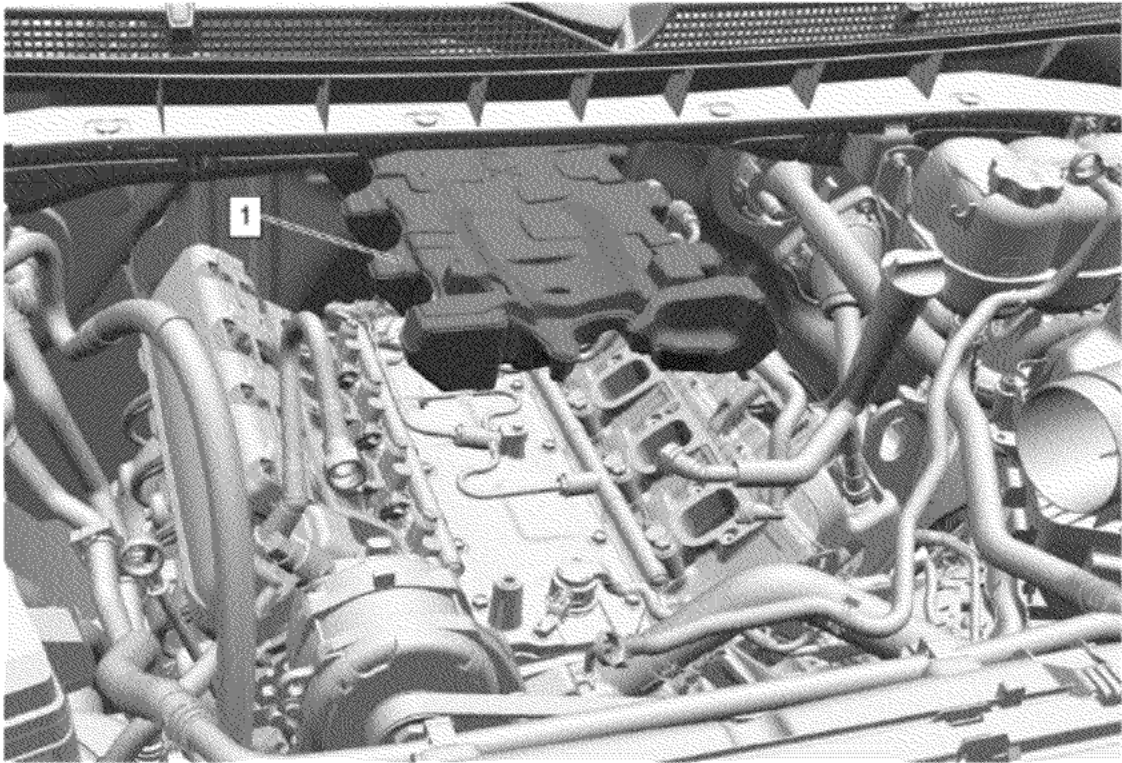

Danger: The noise cancelling foam component **MUST** be replaced if it has been exposed to engine fluids. Failure to replace the noise canceling foam component that has been exposed to engine fluids may result in an engine fire resulting in catastrophic engine damage, and possible injury or death.

166. Fuel Pump Insulator (1) » Remove

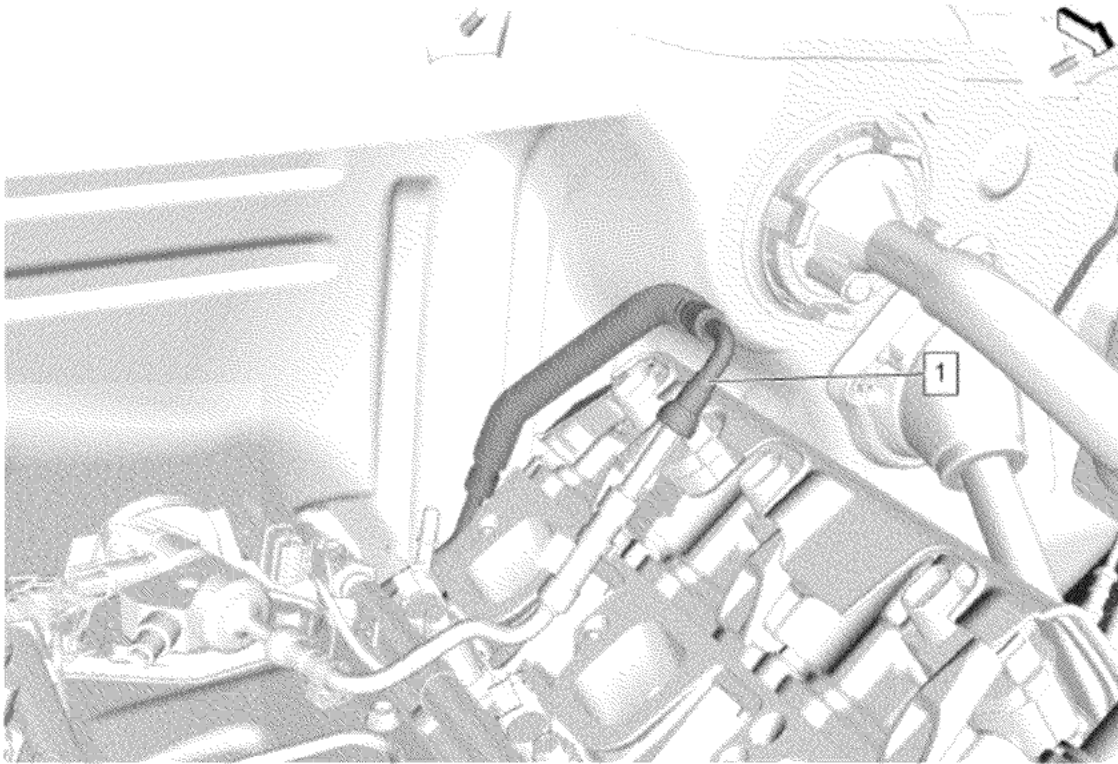

Warning: Refer to Diesel/Gasoline Vapors Warning.

167. Fuel Feed Pipe (1) » Disconnect — Metal Collar Quick Connect Fitting Service

168. Fuel Feed Pipe (1) » Reposition

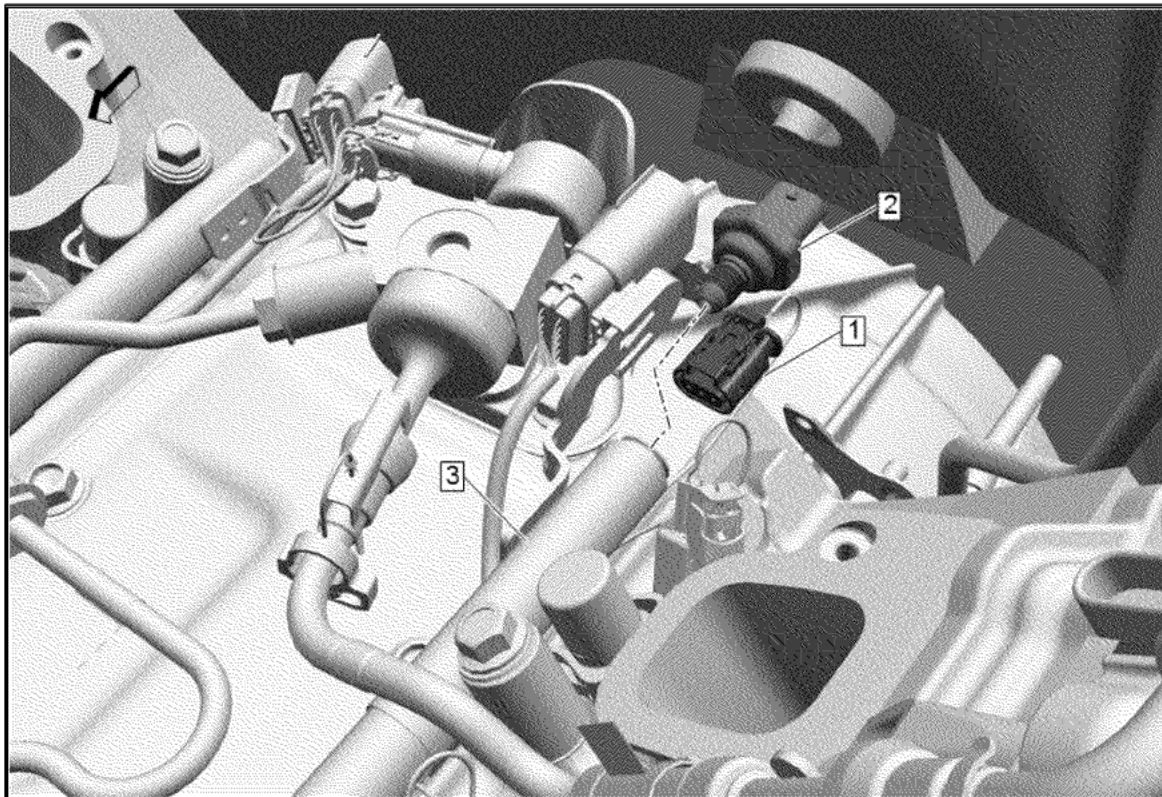

Caution: Refer to [Fuel and Evaporative Emission Hose/Pipe Connection Cleaning Caution](#).

Caution: To tighten or loosen the fuel injection fuel rail fuel pressure sensor, apply force **ONLY** to the attached hexagon. Applying force to the plastic housing of the sensor may damage the sensor.

169. Electrical Connector (1) @ Fuel Rail Pressure Sensor (2) » Disconnect

Note: Some fuel may leak from the fuel rail pressure sensor orifice after the sensor is removed. Dry the area around this orifice after the removal of the sensor using a lint free cloth and inspect the fuel rail pressure sensor sealing surface. The surface should be free of fuel, debris, and burrs.

170. Fuel Rail Pressure Sensor (2) @ Fuel Injection Fuel Rail (3) » Remove

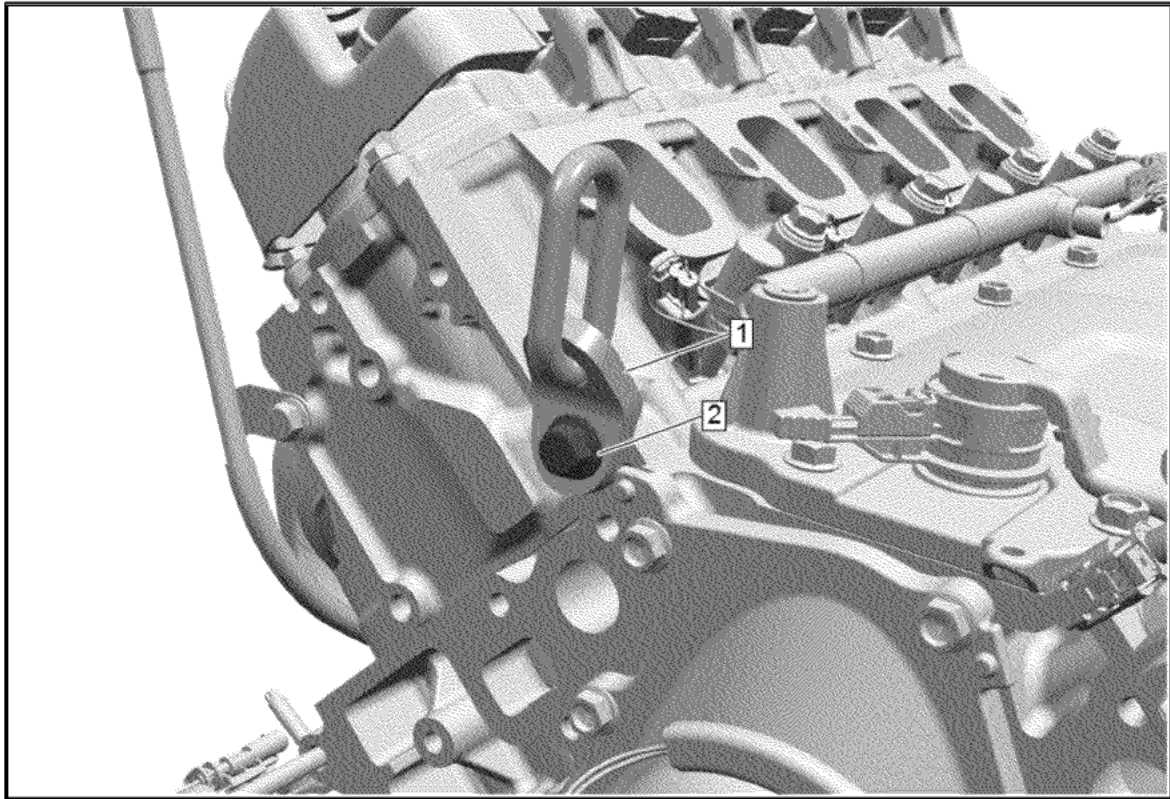

171. Install the *EN-36857* Engine Lift Bracket (1) using the *EN-52059* Engine Support Fixture Adapter Bolt - M10 (2) to the cylinder head and hand tighten.

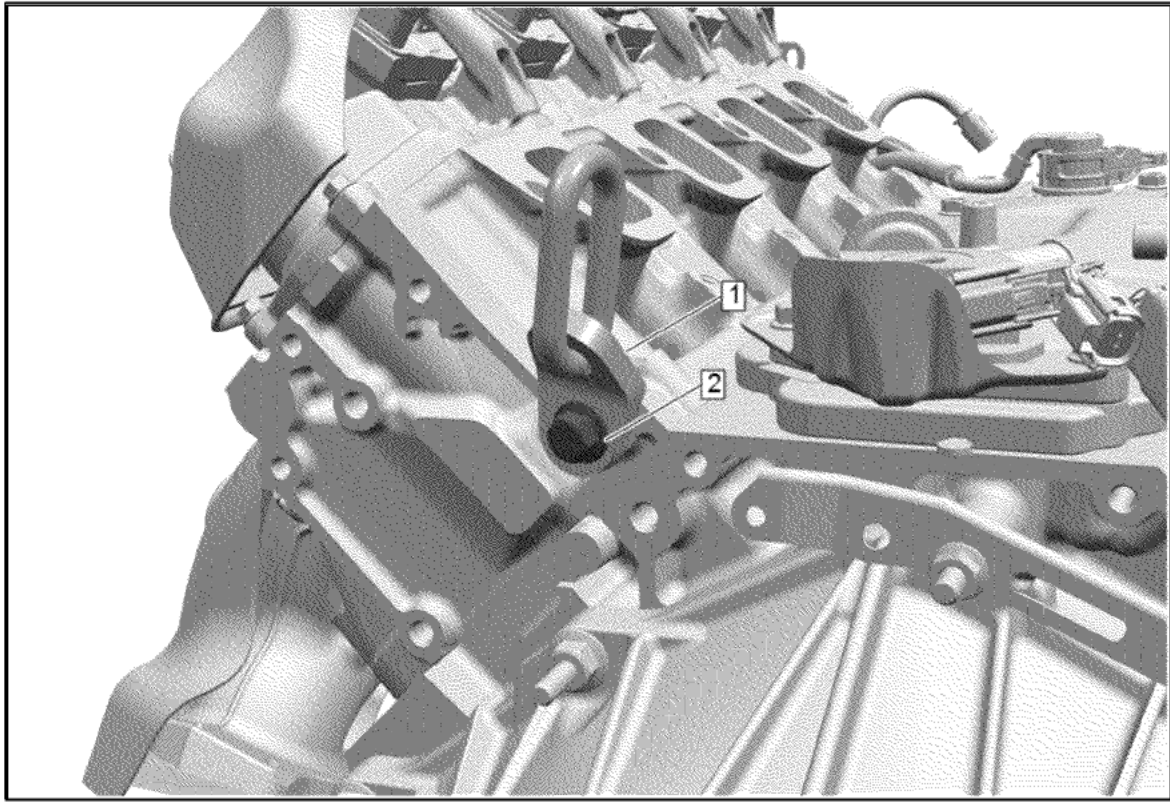

© 2025 General Motors. All rights reserved.

172. Install the *EN-36857* Engine Lift Bracket (1) using the *EN-52059* Engine Support Fixture Adapter Bolt - M10 (2) to the cylinder head and hand tighten.

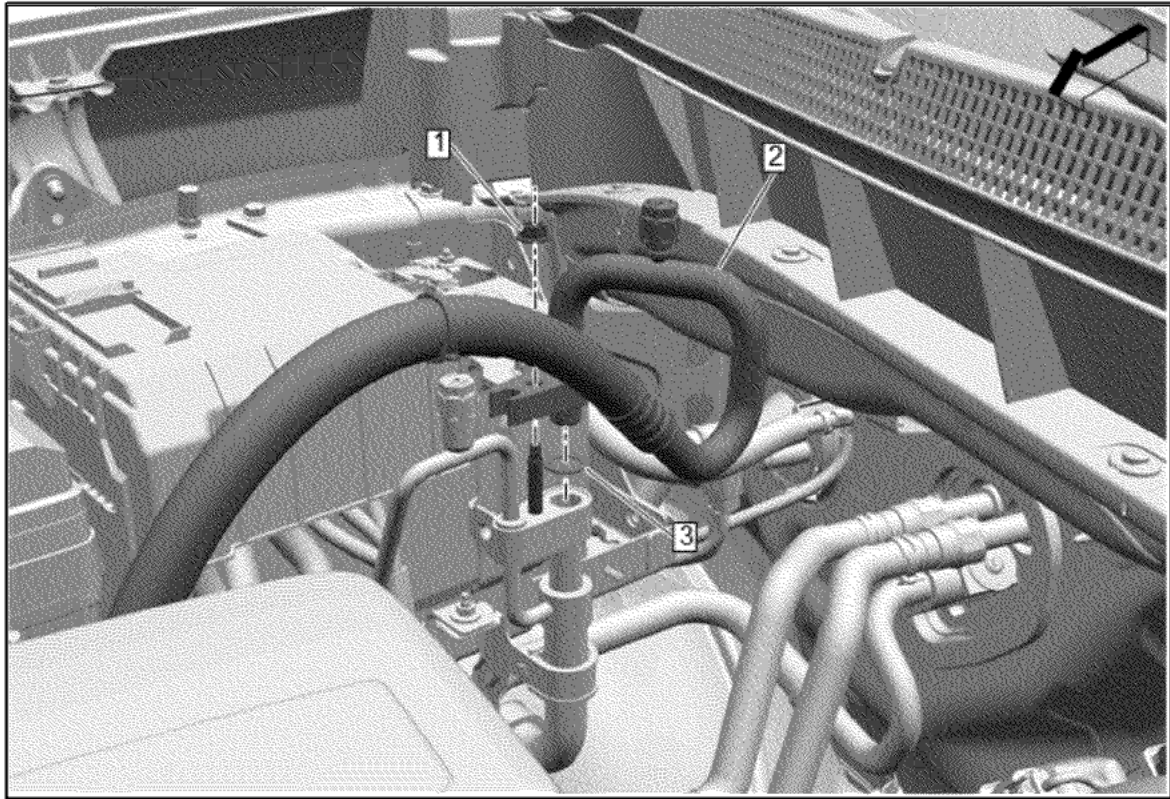

173. Air Conditioning Compressor and Condenser Hose (2) » Position aside

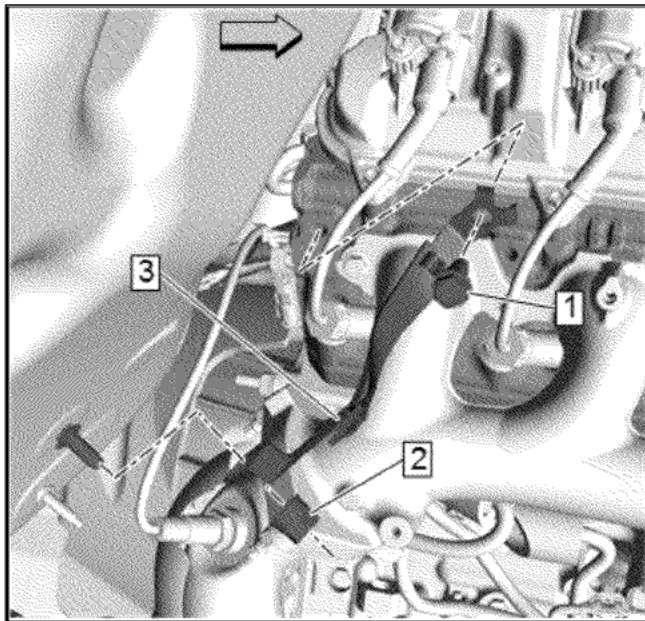

174. Engine Wiring Harness Ground Bolt (1) @ Engine Block » Remove

175. Battery Negative Cable Extension Cable Strap (3) @ Engine Block » Remove

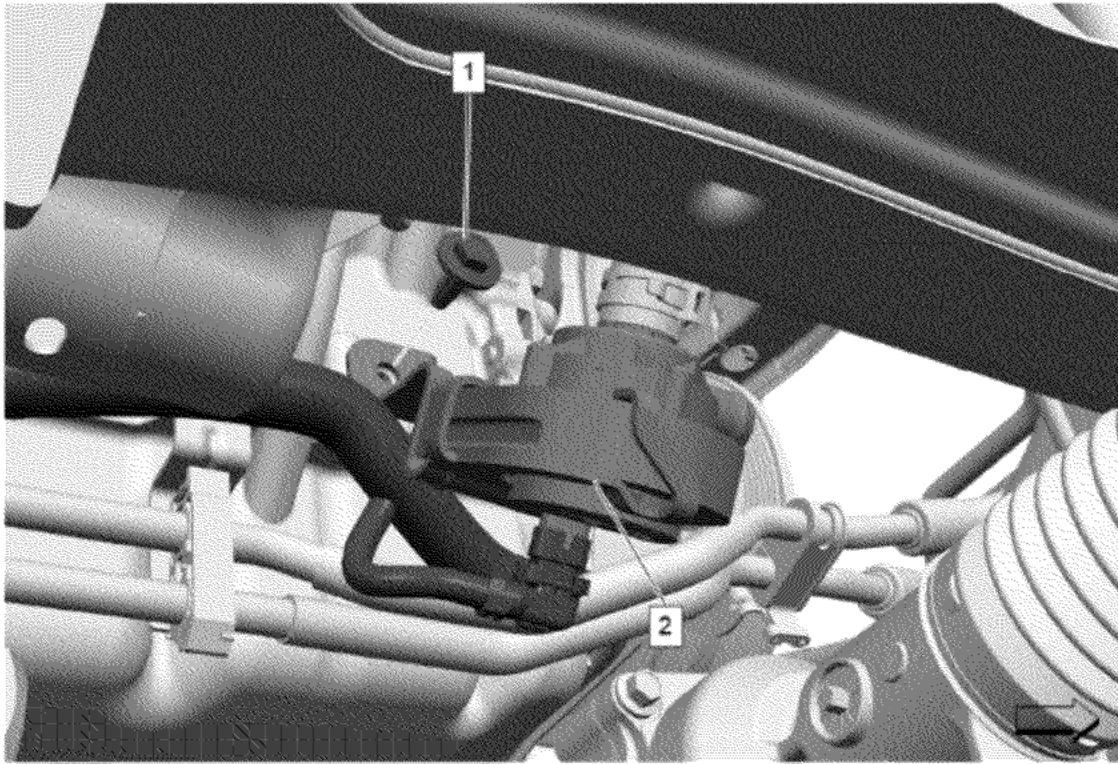

Note: Some components not shown for graphic clarity.

176. Electrical Connector @ Heater Coolant Pump (2) » Disconnect

177. Heater Water Auxiliary Pump Bolt (1) » Remove

178. Remove the heater coolant pump and heater water auxiliary pump bracket (2) as assembly and position aside.

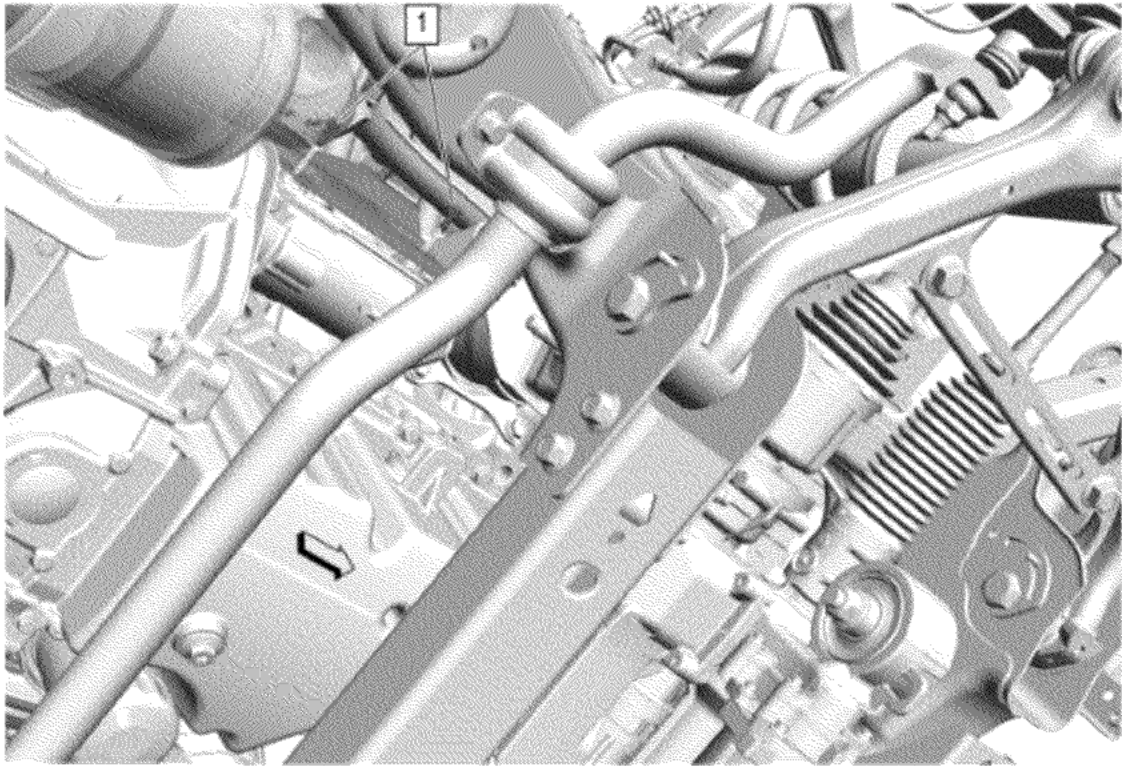

179. Starter Heat Shield Bolt (1) » Remove [2x]

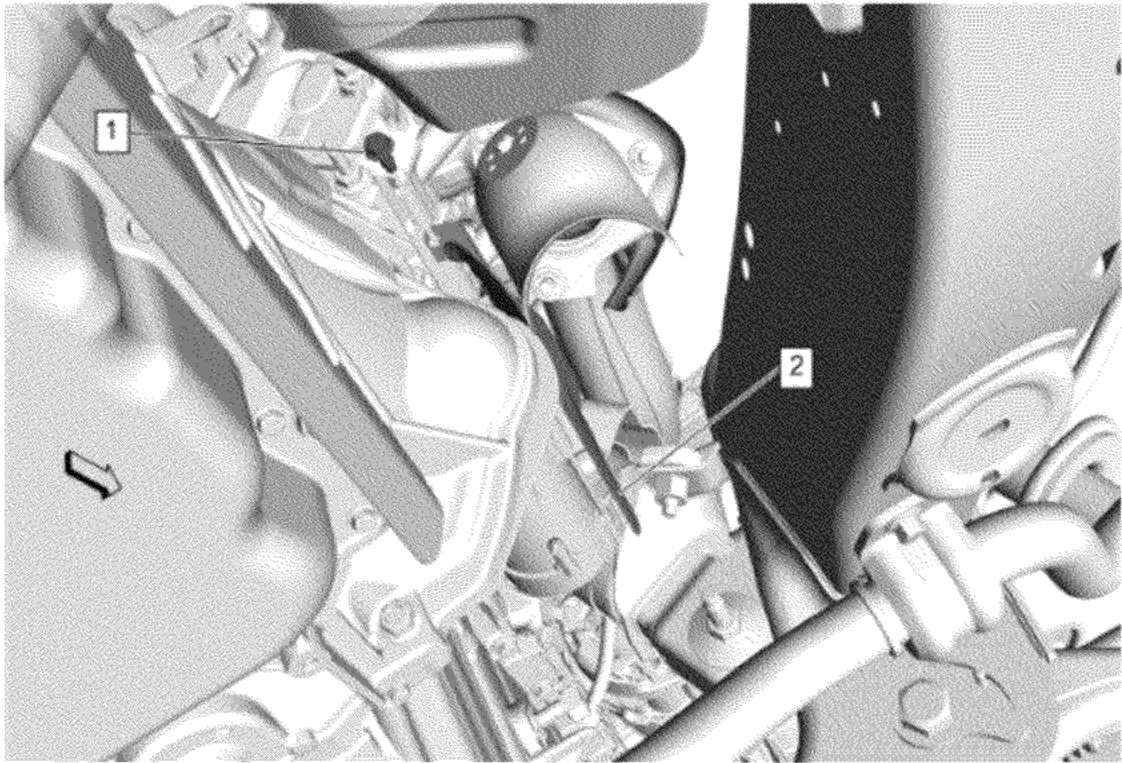

180. Starter Heat Shield Bolt (1) » Remove

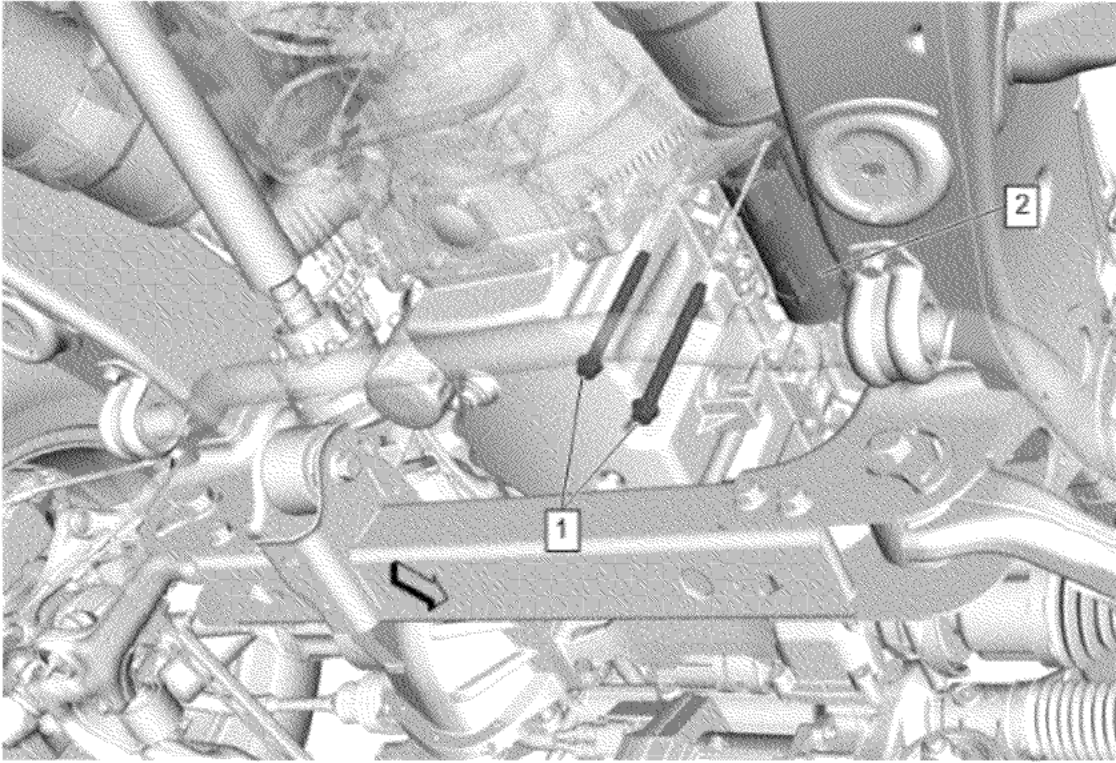
181. Starter Heat Shield (2) » Remove

© 2025 General Motors. All rights reserved.

182. Starter Bolt (1) » Remove [2x]**183. Reposition the starter (2) to access the electrical connections.**

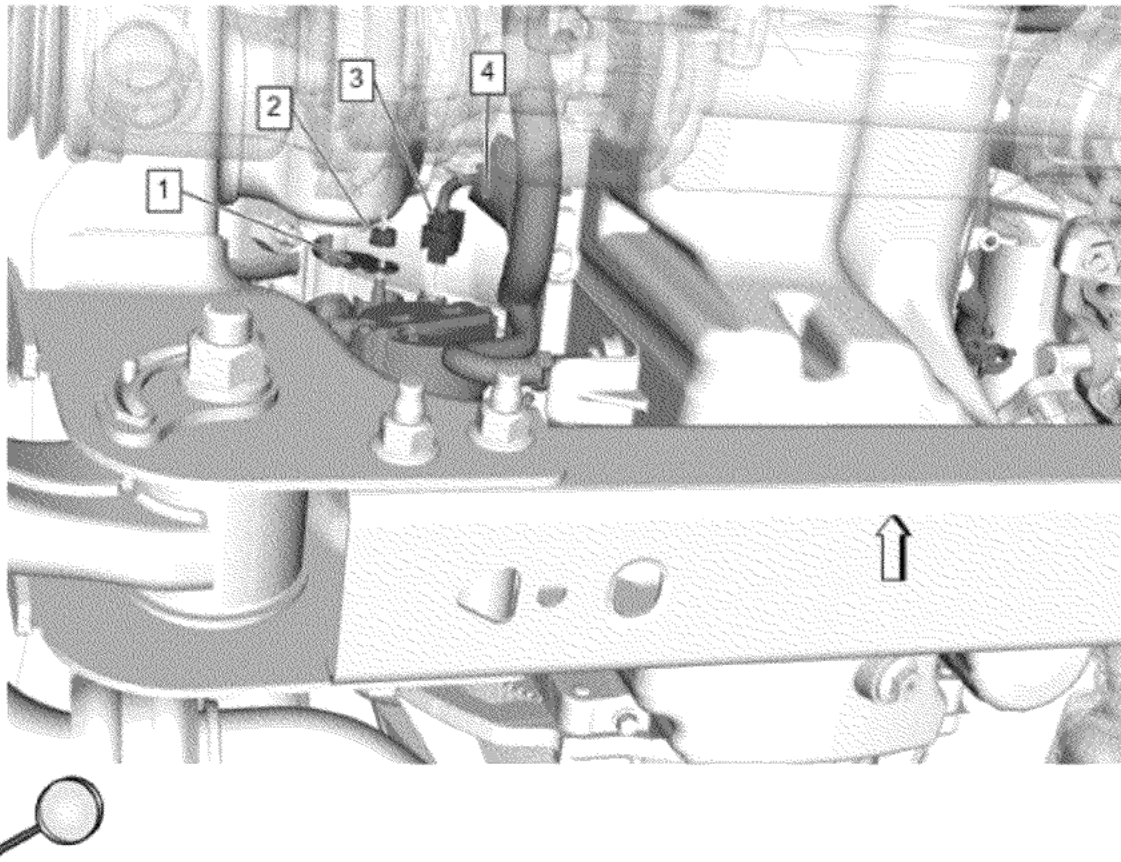

© 2025 General Motors. All rights reserved.

- 184. Protective Sleeve (4) » Reposition
- 185. Starter Solenoid Cable Nut (2) » Remove
- 186. Starter Solenoid Cable (1) » Remove
- 187. Electrical Connector (3) » Disconnect

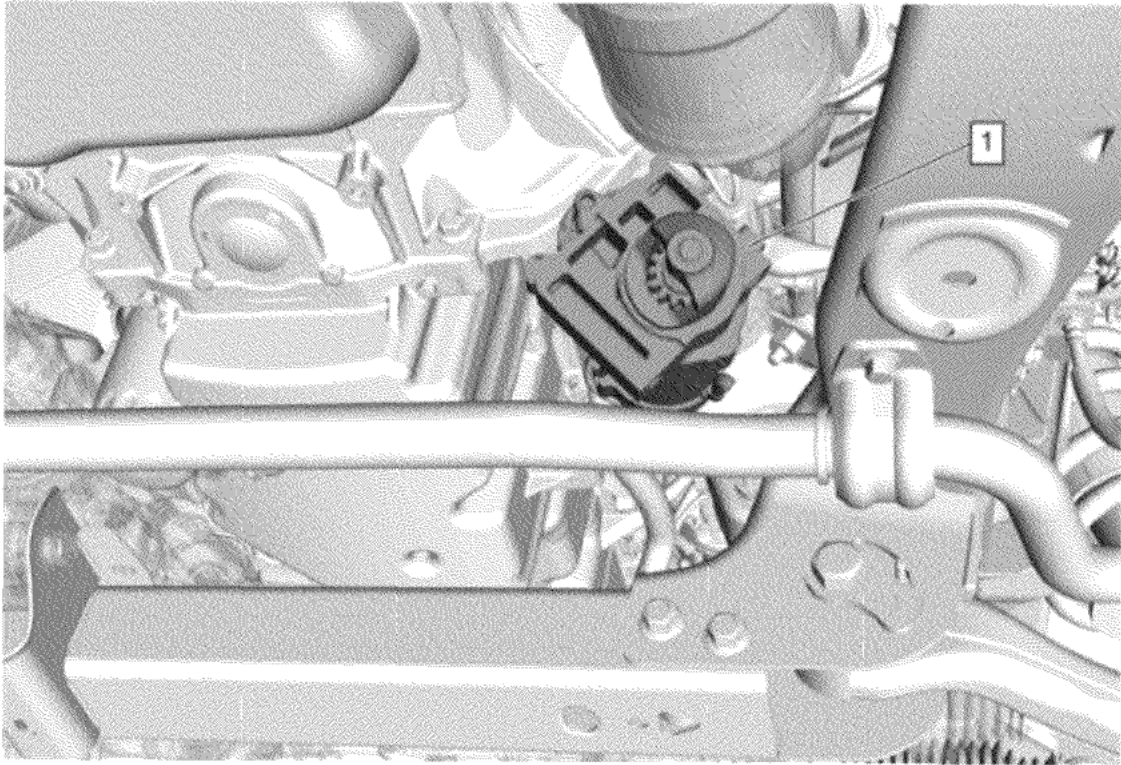

188. Starter (1) » Remove

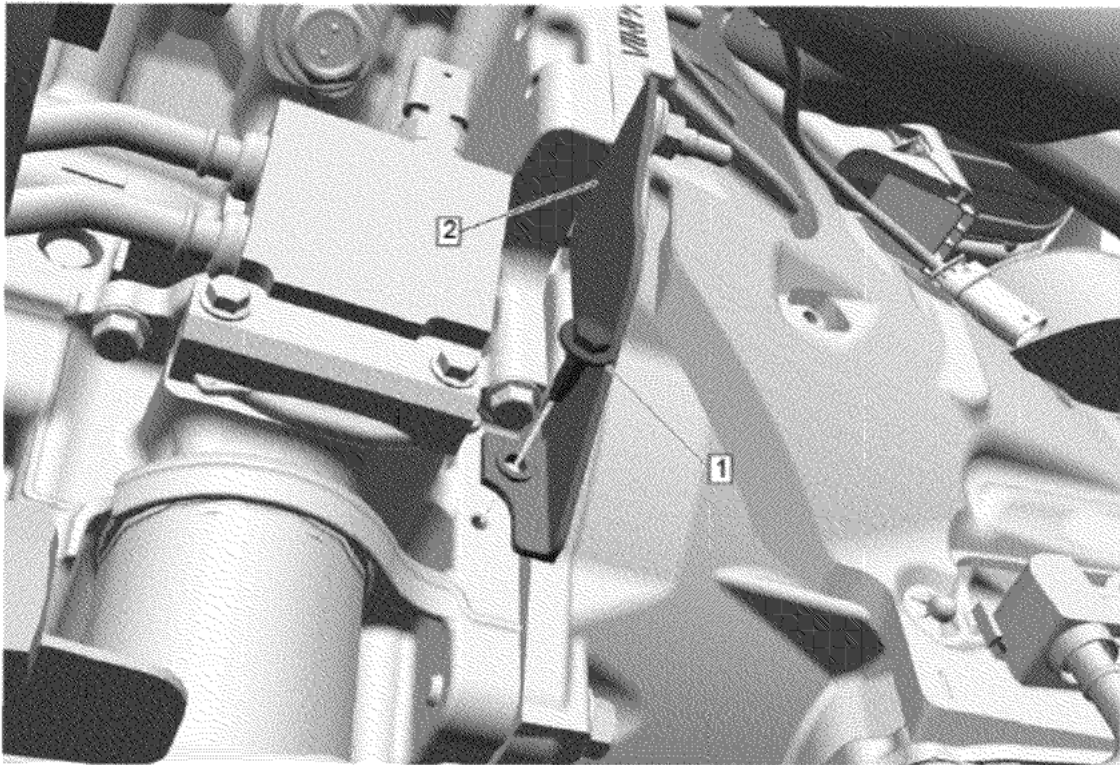

189. Torque Converter Cover Bolt - Left Side (1) » Remove

190. Transmission Converter Cover - Left Side (2) » Remove

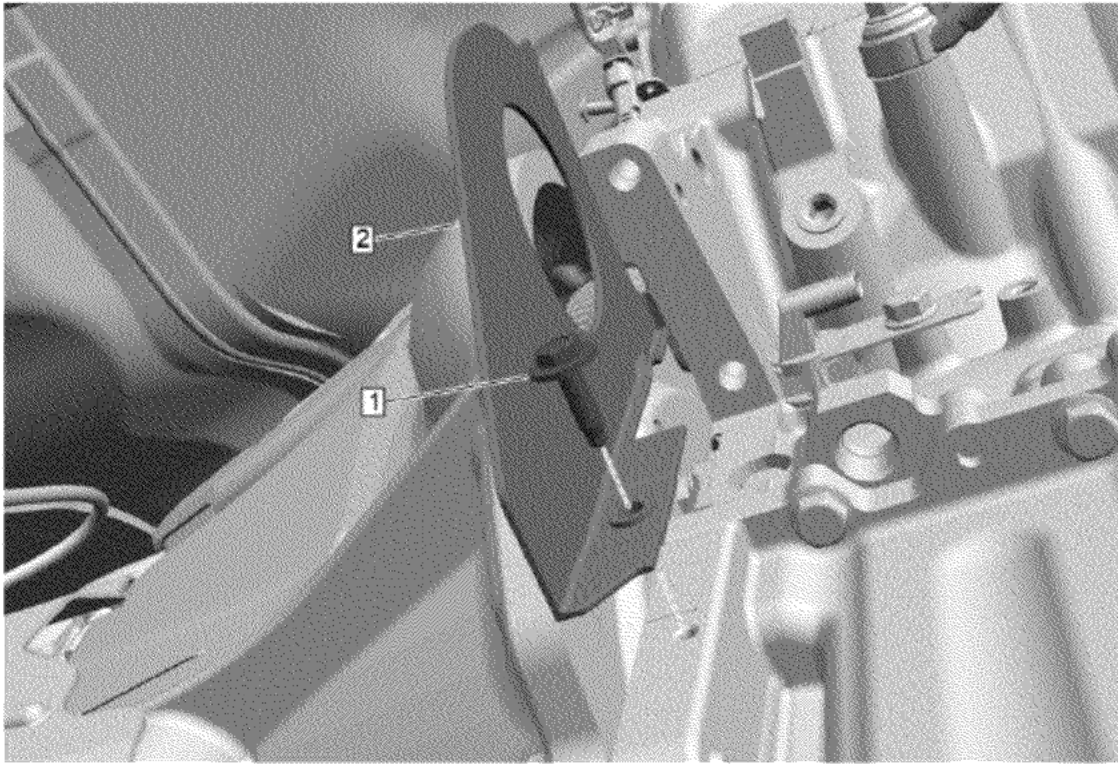

191. Torque Converter Cover Bolt - Right Side (1) » Remove

192. Transmission Converter Cover - Right Side (2) » Remove

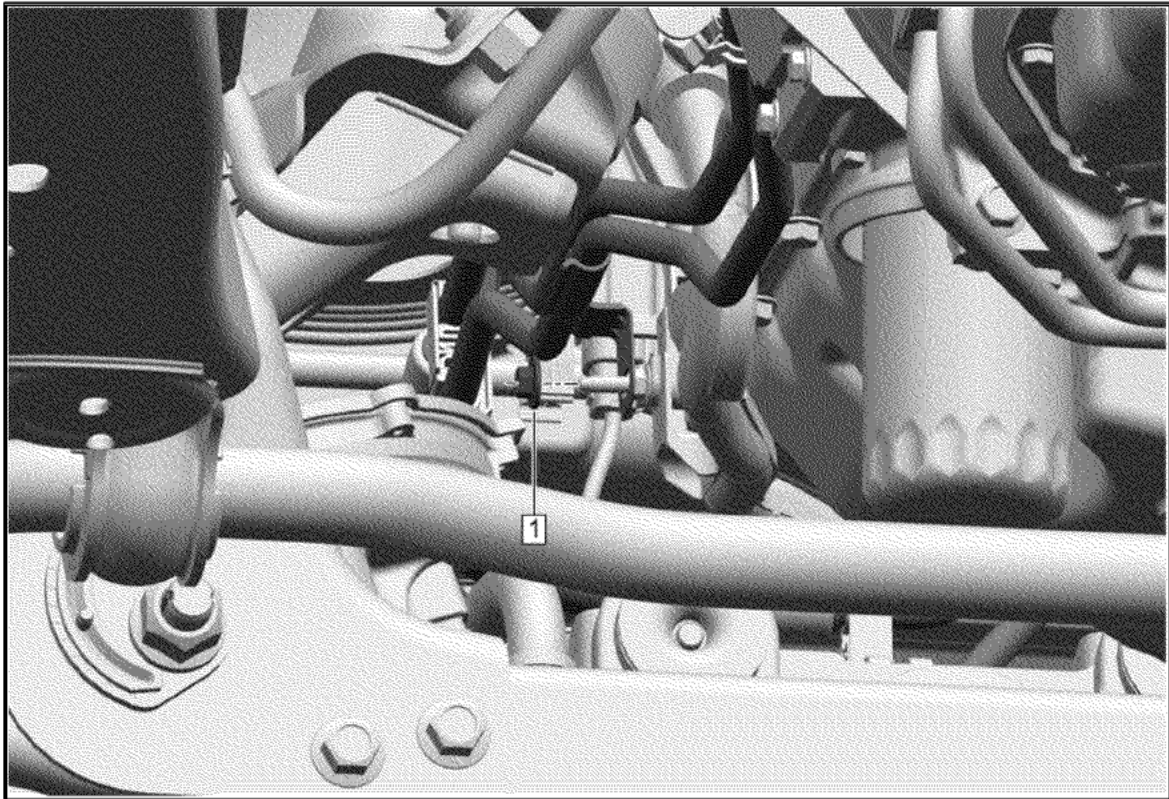

193. Engine Oil Cooler Hose Bracket Nut (1) » Remove

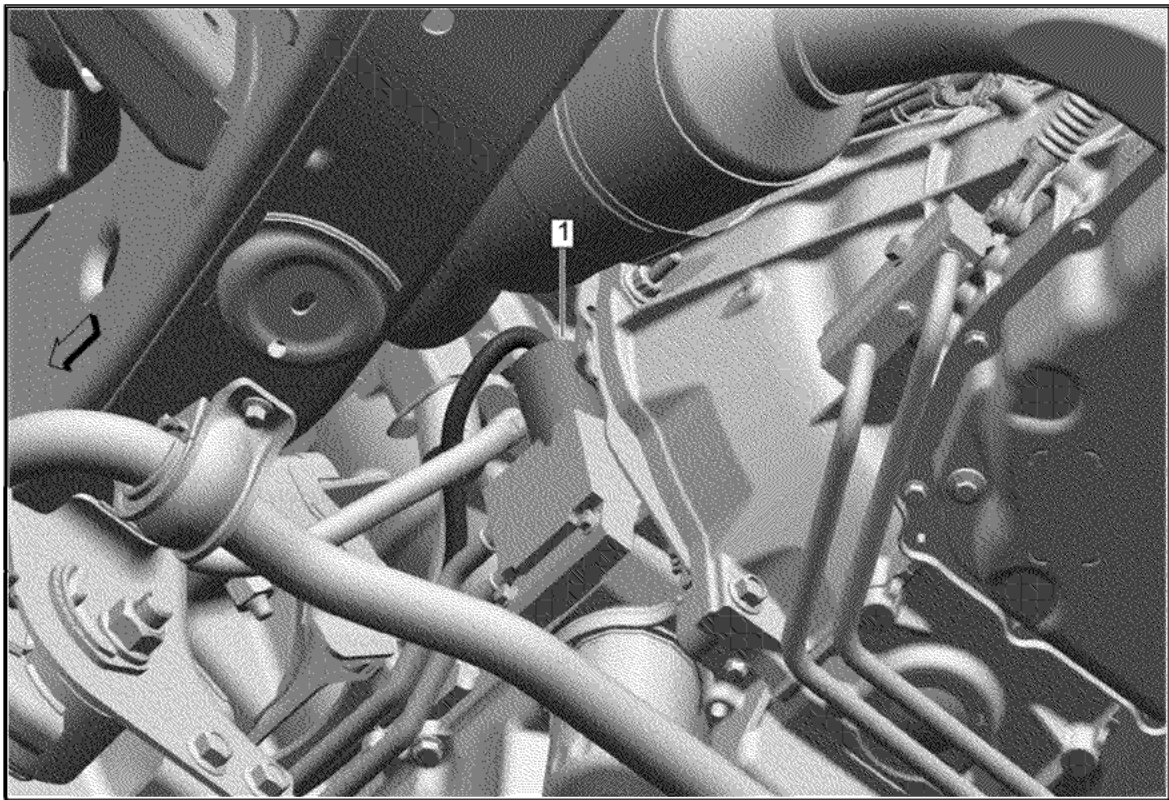

194. Engine Oil Pressure Sensor Sleeve (1) » Remove

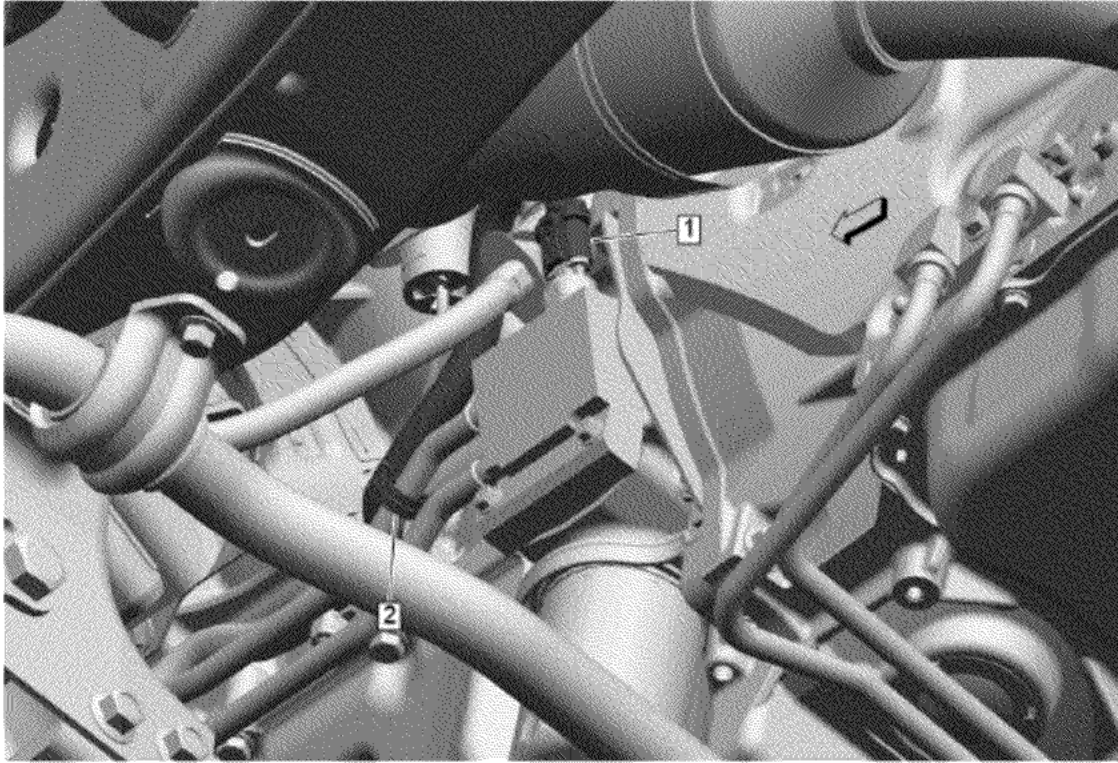

195. Electrical Connector (1) @ Engine Oil Pressure Sensor » Disconnect

196. Wiring Harness Retainer (2) @ Engine Oil Cooler Hose » Remove

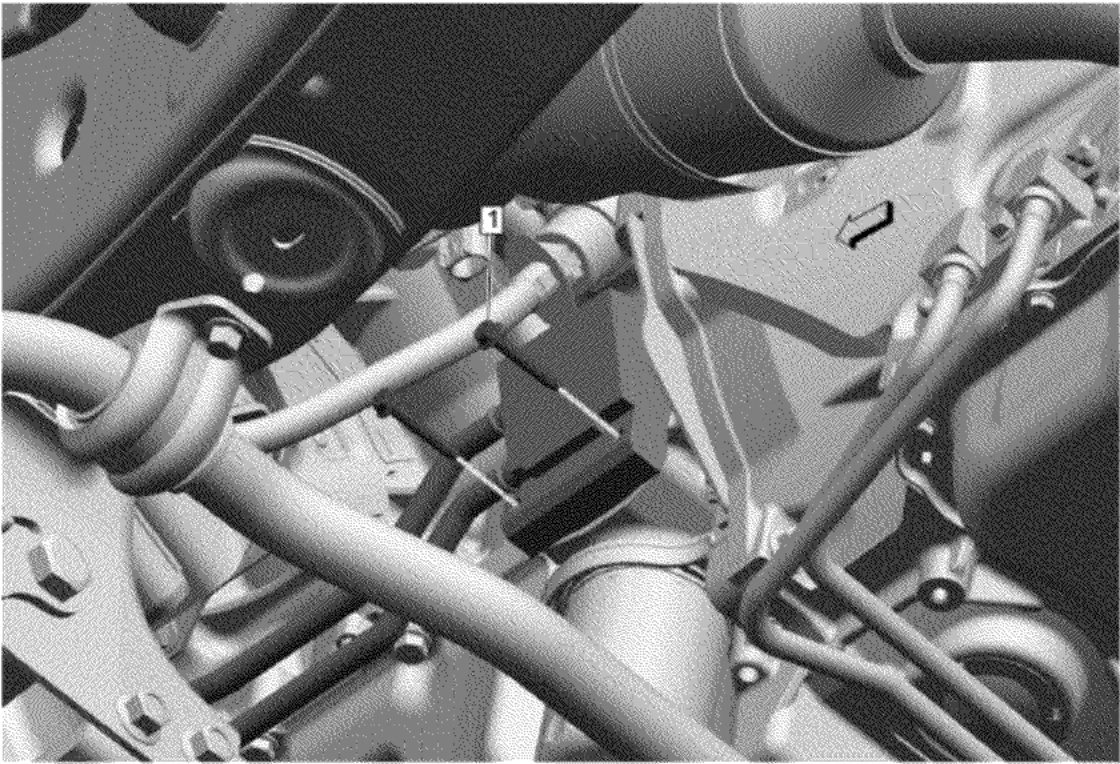

197. Engine Oil Cooler Coolant Hose Bolt (1) » Remove [2x]

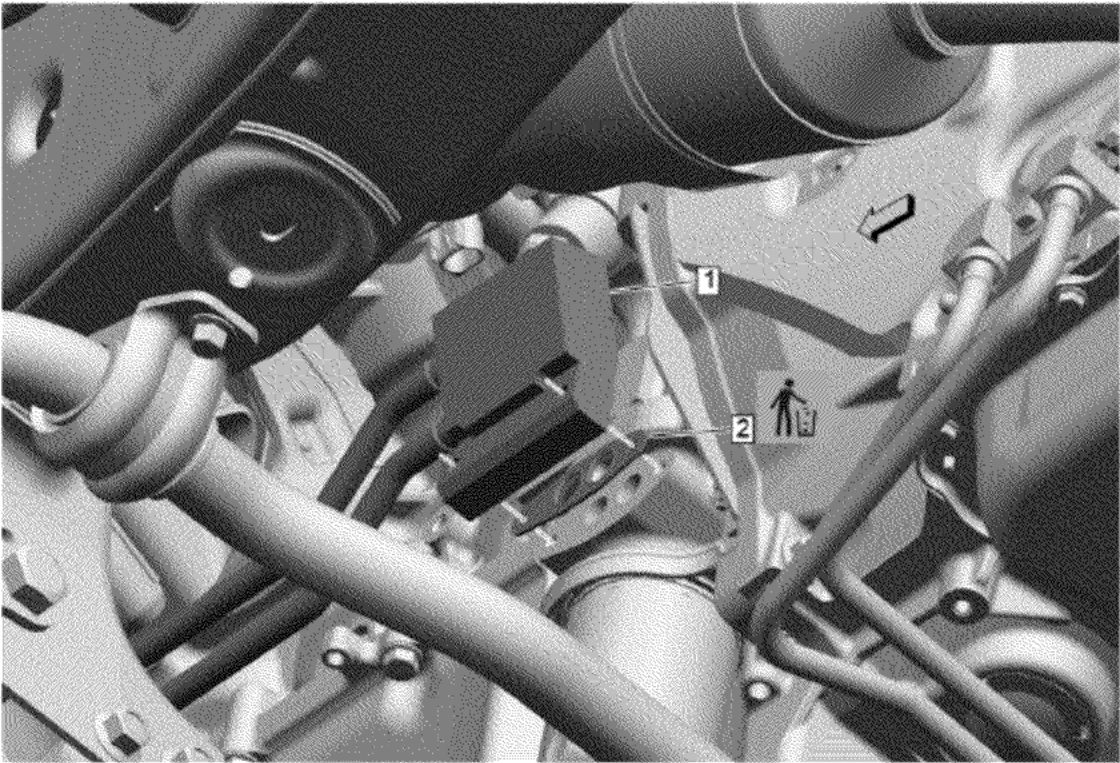

198. Engine Oil Cooler Hose (1) @ Oil Pan » Reposition

199. Engine Oil Cooler Gasket (2) » Remove and DISCARD

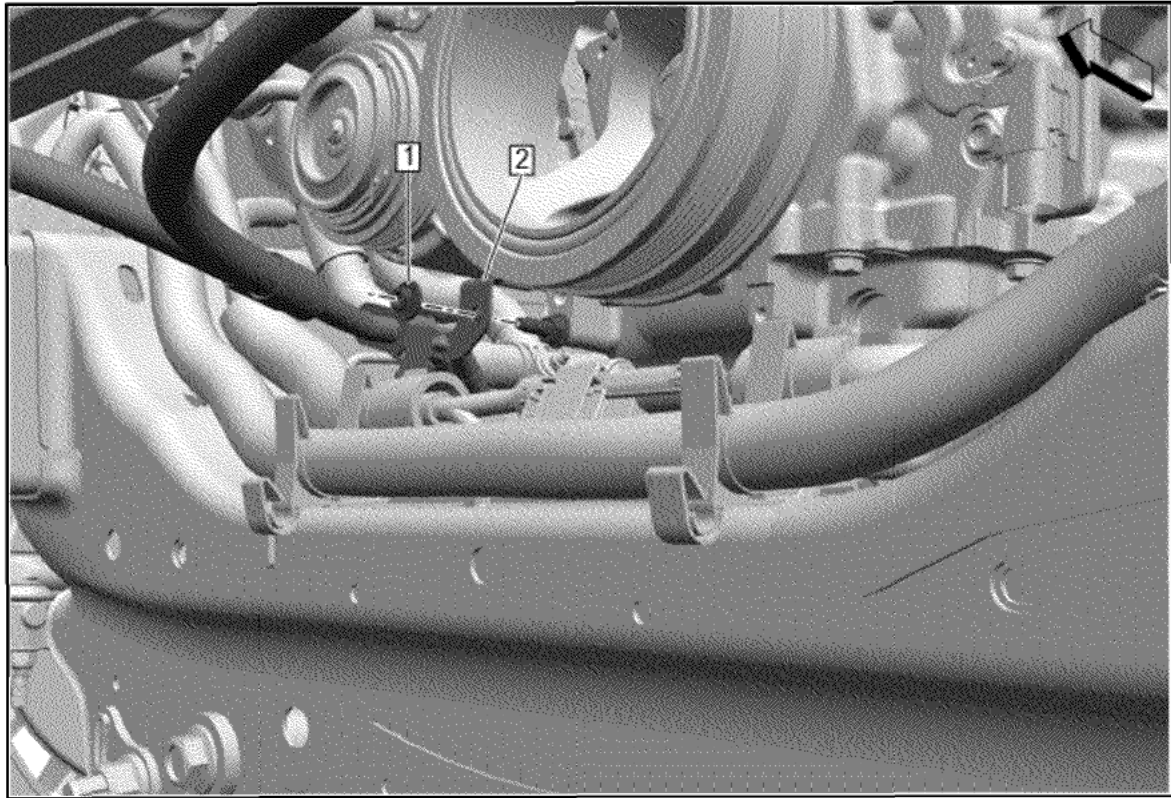

© 2025 General Motors. All rights reserved.

200. Remove the transmission fluid auxiliary cooler pipe bracket nut (1).

201. Remove the transmission fluid cooler inlet and outlet pipe bracket (2).

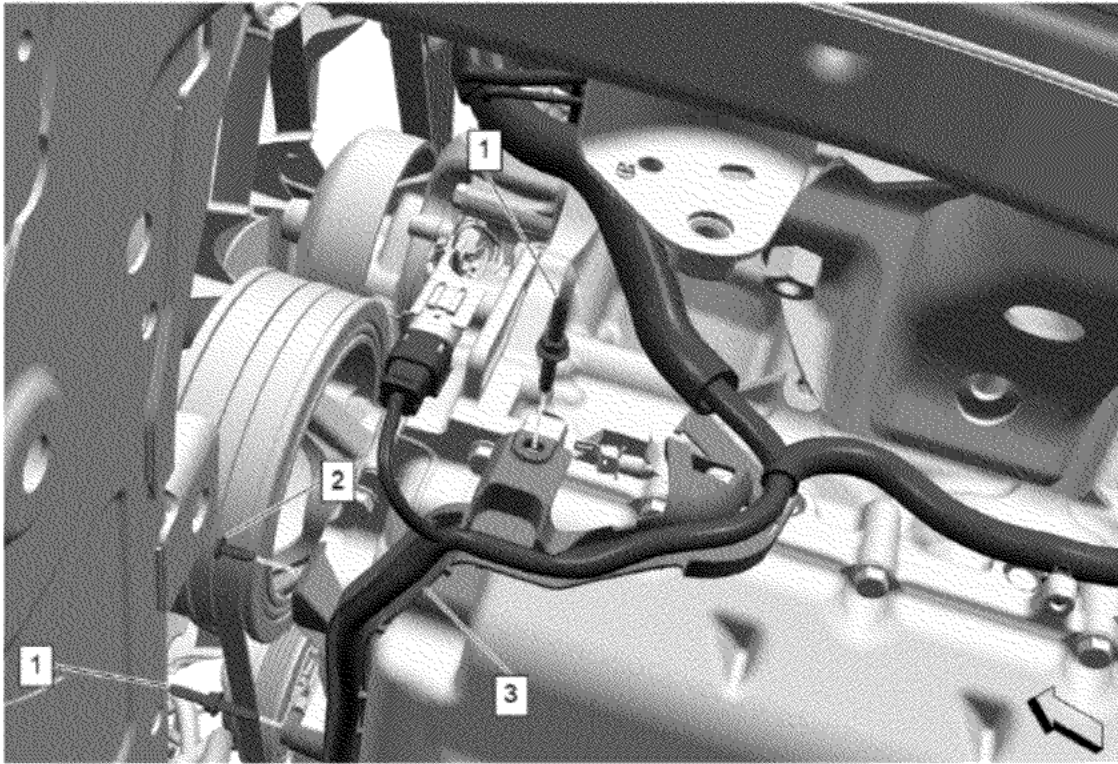

- 202. Engine Wiring Harness Retainer (2) » Remove
- 203. Engine Wiring Harness Ground Stud (1) » Remove [2x]
- 204. Engine Wiring Harness (3) @ Oil Pan » Reposition

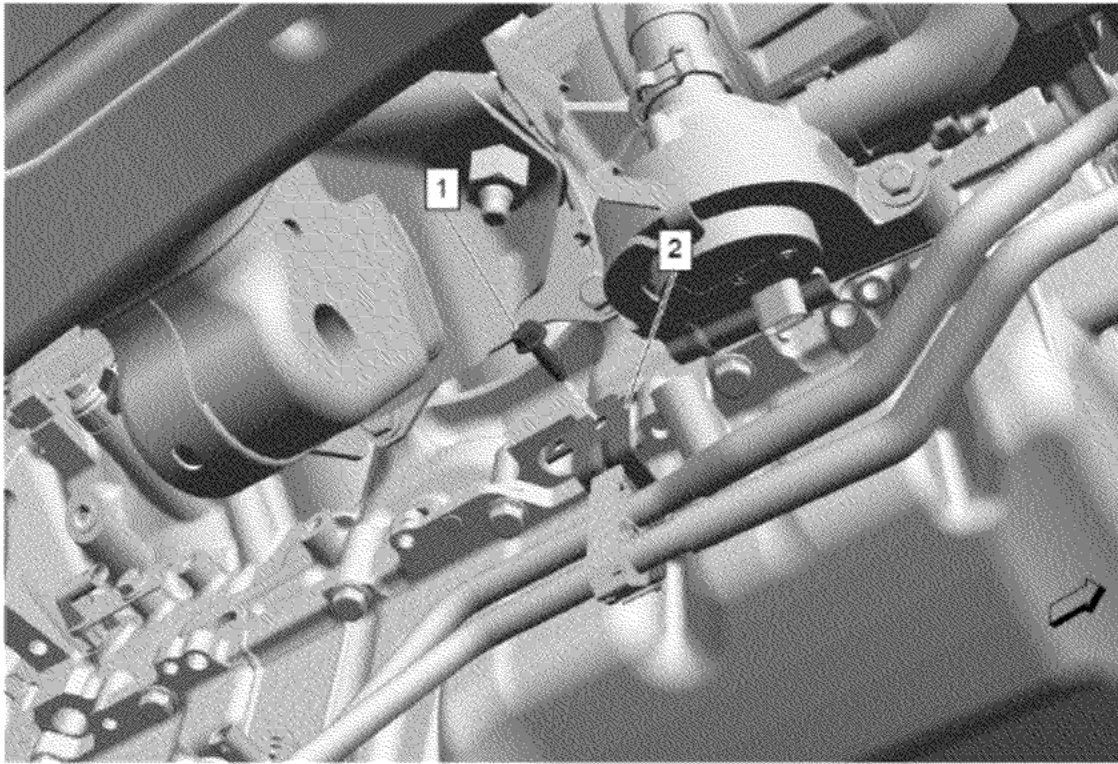

205. Transmission Fluid Cooler Pipe Clip Bolt (1) @ Oil Pan » Remove

Note: Components removed in graphic to better illustrate service parts.

206. Transmission Fluid Cooler Pipe Clip Bracket (2) @ Oil Pan » Remove

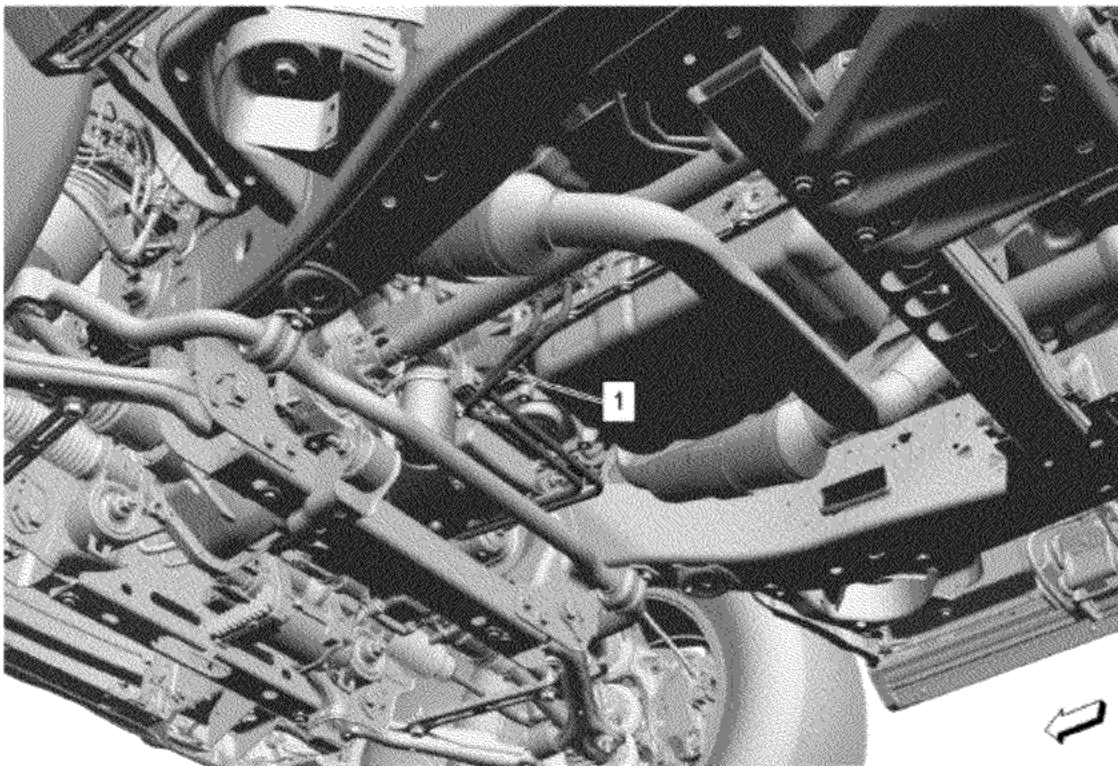

207. Reposition the transmission cooler inlet and outlet pipe (1) as necessary.

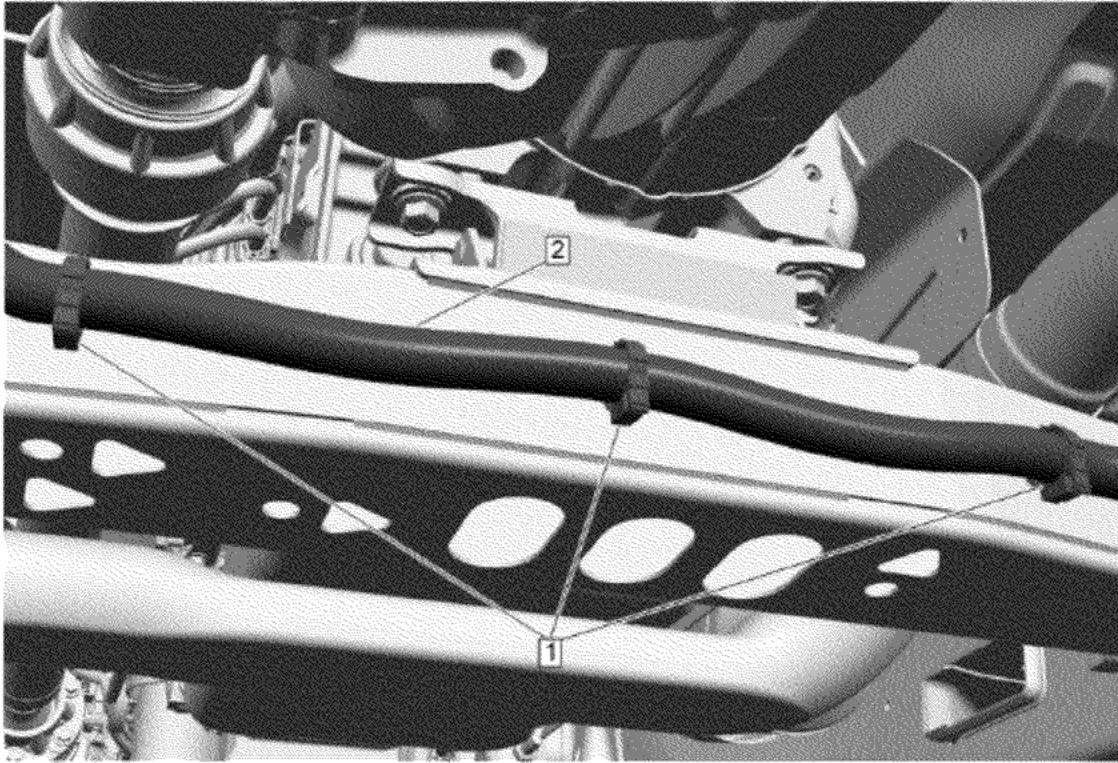

© 2025 General Motors. All rights reserved.

208. { If equipped } Remove the 3 wiring harness retainers (1) from the transmission support crossmember, and reposition the wiring harness (2) as necessary.

209. Support the transmission with a suitable jack.

© 2025 General Motors. All rights reserved.

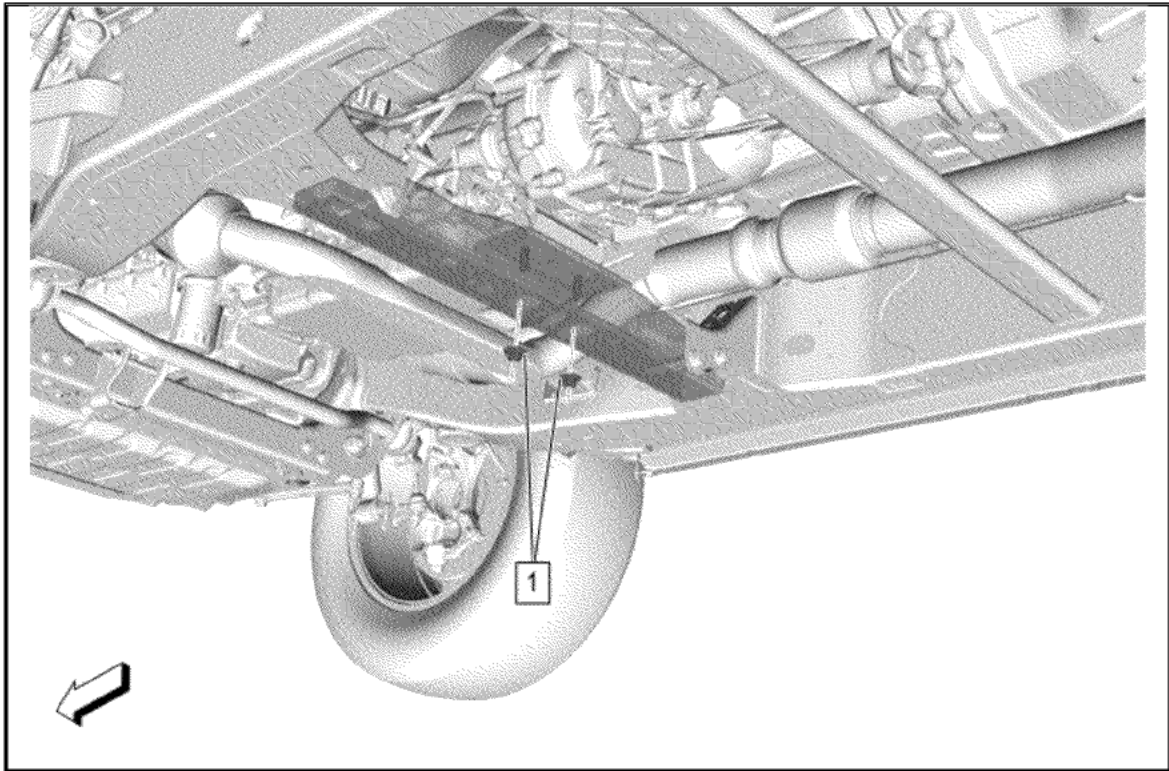

210. Transmission Mount Nut (1) » Remove [2x]

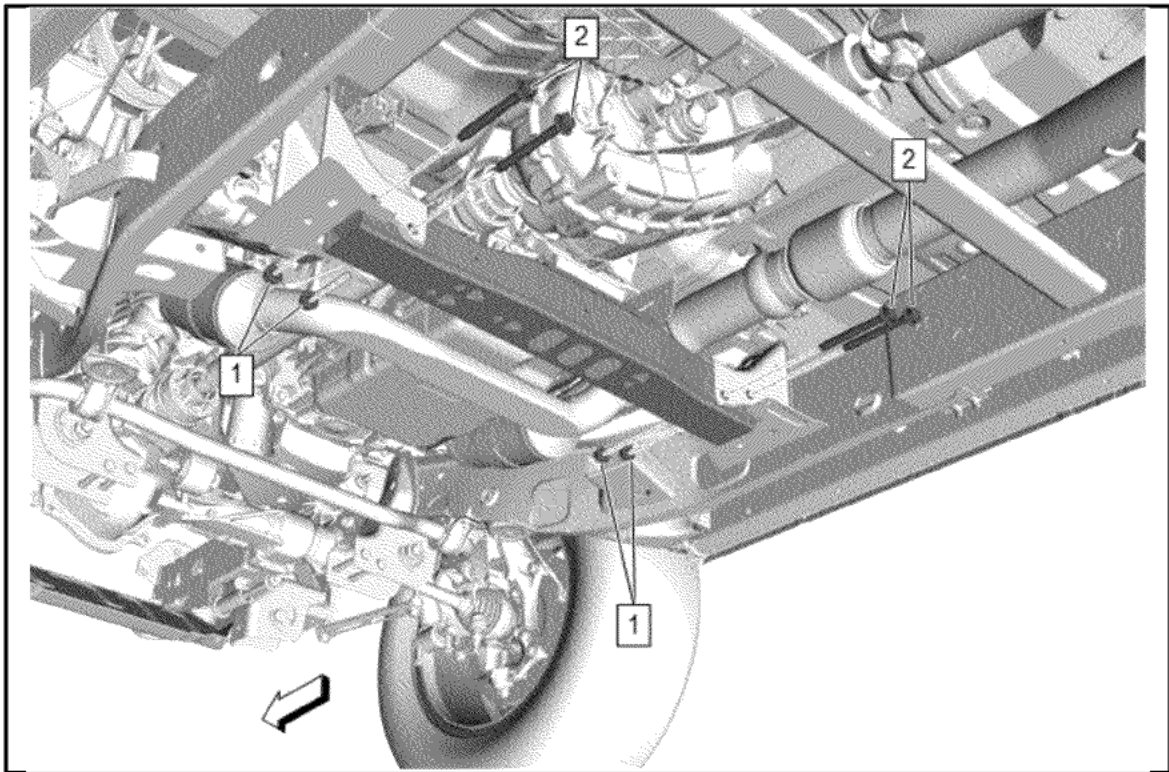

211. Transmission Support Crossmember Nut (1) » Remove [4x]

212. Transmission Support Crossmember Bolt (2) » Remove [4x]

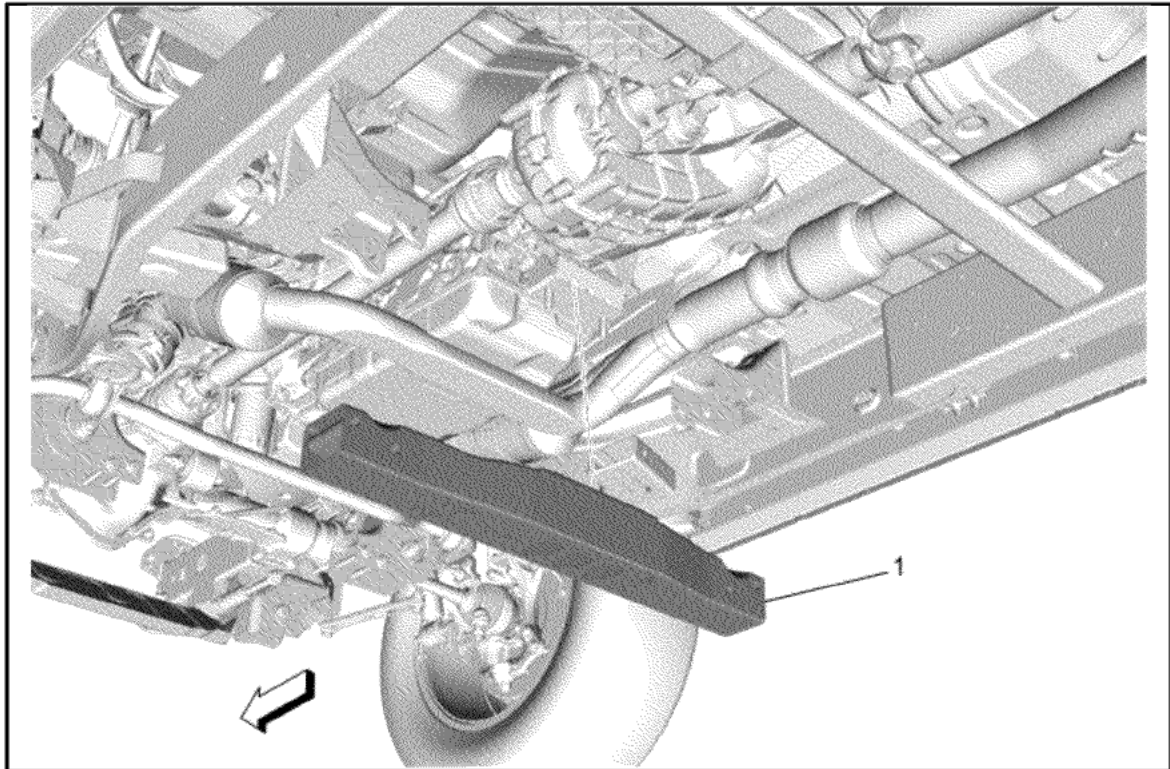

© 2025 General Motors. All rights reserved.

213. Transmission Support Crossmember (1) » Remove

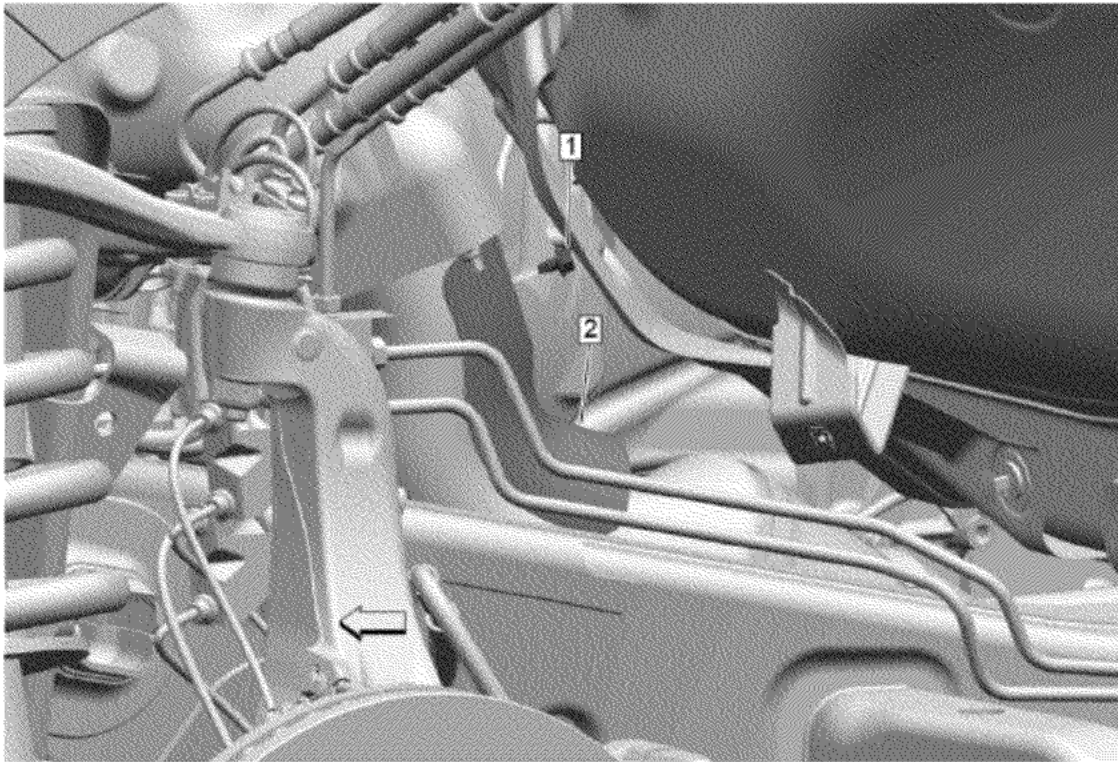

- 214. Exhaust Heat Shield Bolt - Left Side (1) » Remove
- 215. Exhaust Front Pipe Heat Shield - Left Side (2) » Remove

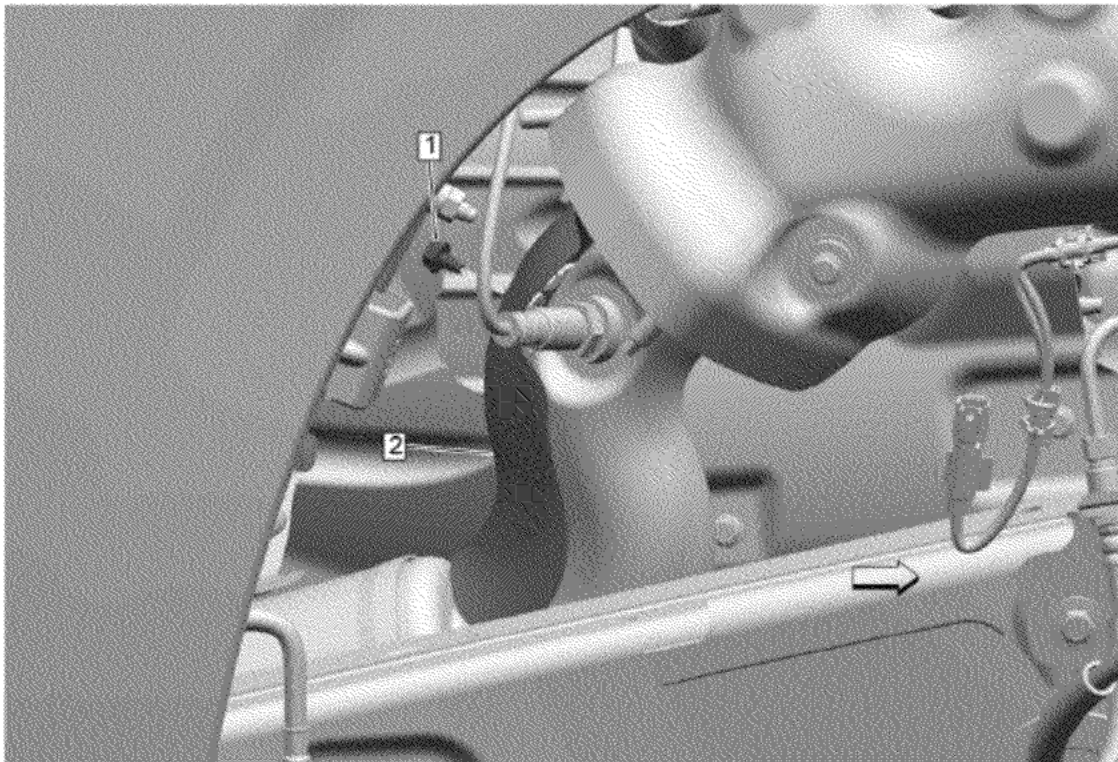

216. Exhaust Heat Shield Bolt - Right Side (1) » Remove

217. Exhaust Front Pipe Heat Shield - Right Side (2) » Remove

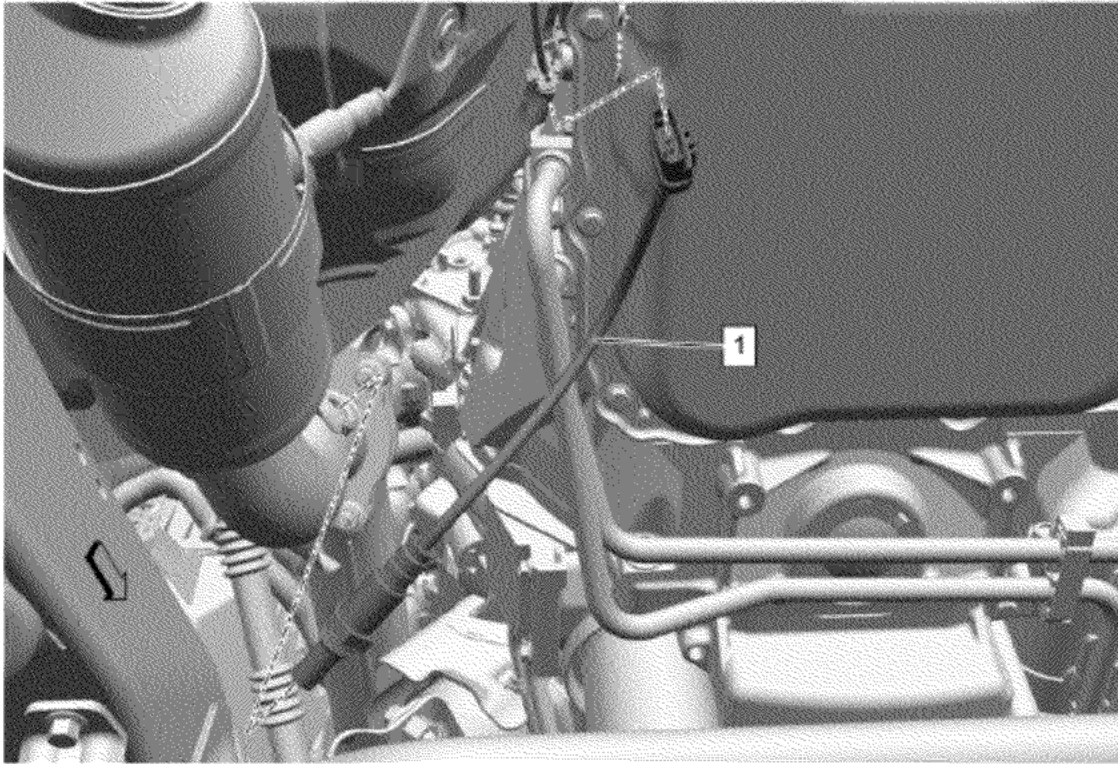

© 2025 General Motors. All rights reserved.

Warning: Avoid contact with HOT components. Wear safety glasses and protective gloves to avoid personal injury.

Caution: Refer to Heated Oxygen and Oxygen Sensor Caution.

Note:

- The heated oxygen sensor in-line connector and louvered end MUST be kept clear of all grease, dirt, and other contaminants. Do NOT use cleaning solvents of any type. Do NOT drop or roughly handle the heated oxygen sensor (1).
- The heated oxygen sensor (1) MAY be difficult to remove when the engine temperature is less than 48°C (120°F).

218. Electrical Connector @ Heated Oxygen Sensor - Bank 1 Sensor 1 » Disconnect

219. Using a suitable tool, remove the heated oxygen sensor (1).

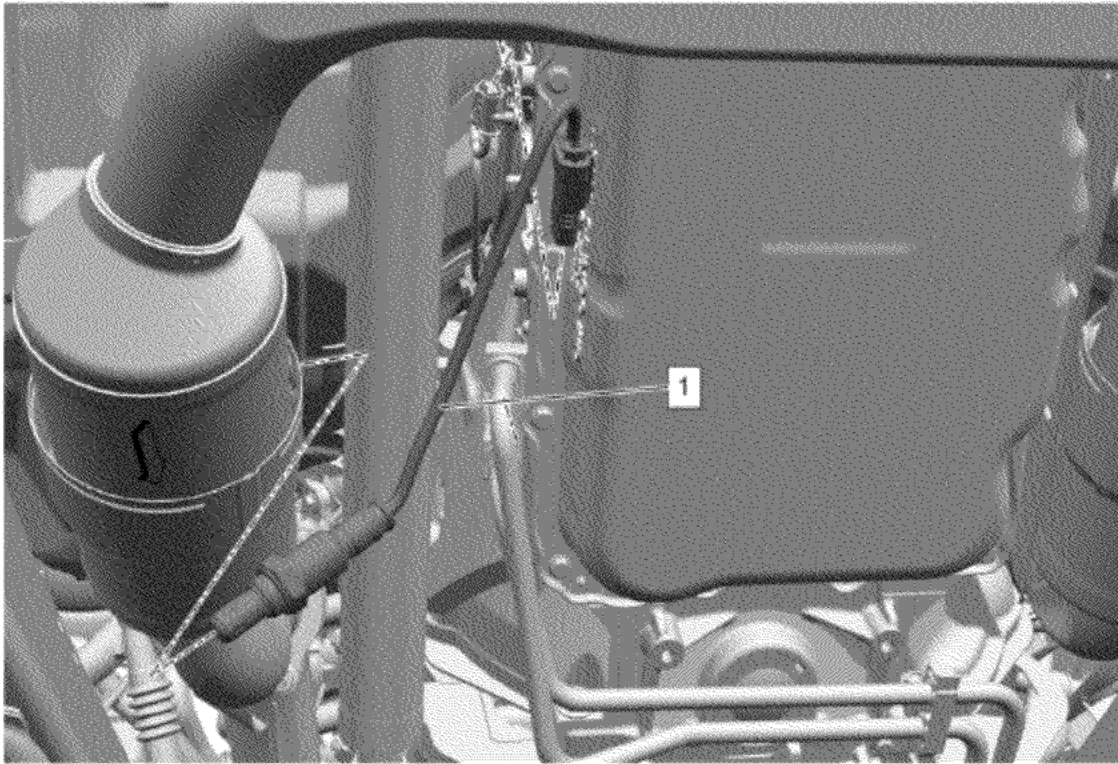

© 2025 General Motors. All rights reserved.

Warning: Avoid contact with HOT components. Wear safety glasses and protective gloves to avoid personal injury.

Caution: Refer to Heated Oxygen and Oxygen Sensor Caution.

220. Electrical Connector @ Heated Oxygen Sensor - Bank 1 Sensor 2 » Disconnect

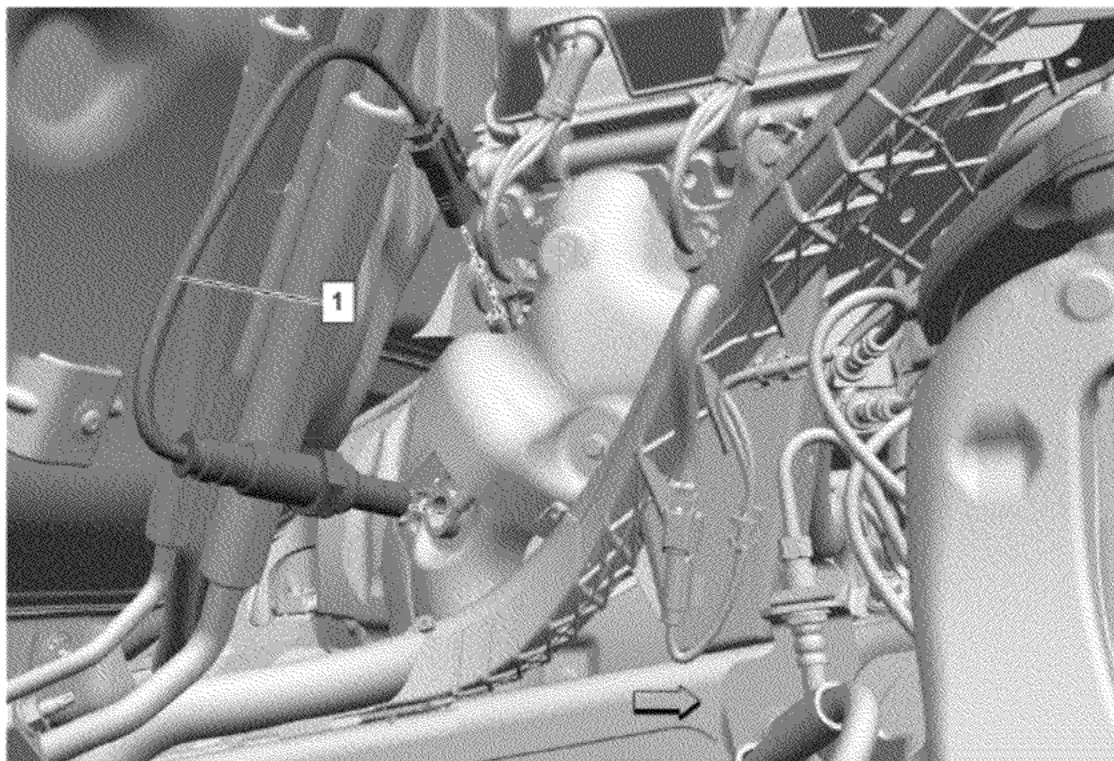

Warning: Avoid contact with HOT components. Wear safety glasses and protective gloves to avoid personal injury.

Caution: Refer to Heated Oxygen and Oxygen Sensor Caution.

Note:

- The heated oxygen sensor in-line connector and louvered end MUST be kept clear of all grease, dirt, and other contaminants. Do NOT use cleaning solvents of any type. Do NOT drop or roughly handle the sensor.
- The heated oxygen sensor MAY be difficult to remove when the engine temperature is less than 48°C (120°F).

221. Electrical Connector @ Heated Oxygen Sensor - Bank 2 Sensor 1 » Disconnect

222. Using a suitable tool, remove the heated oxygen sensor (1).

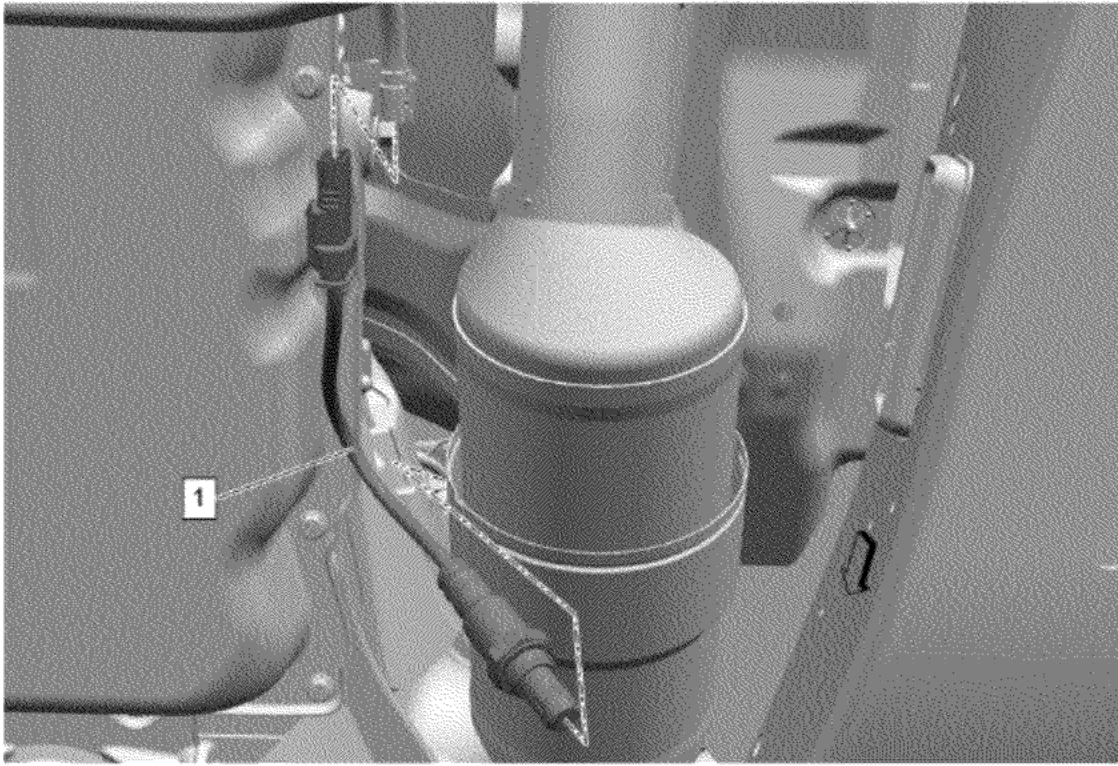

© 2025 General Motors. All rights reserved.

Warning: Avoid contact with HOT components. Wear safety glasses and protective gloves to avoid personal injury.

Caution: Refer to Heated Oxygen and Oxygen Sensor Caution.

223. Electrical Connector @ Heated Oxygen Sensor - Bank 2 Sensor 2 » Disconnect

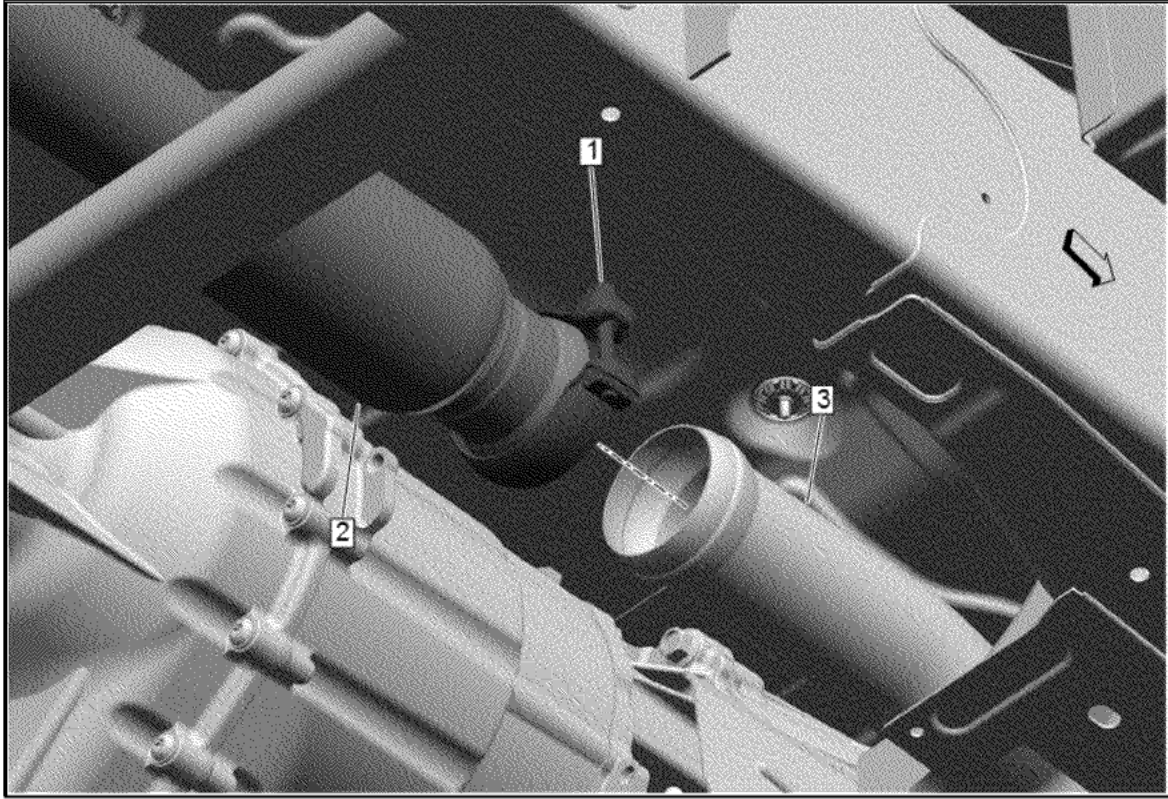

© 2025 General Motors. All rights reserved.

Warning: Avoid contact with HOT components. Wear safety glasses and protective gloves to avoid personal injury.

224. Exhaust Pipe Clamp (1) » Loosen

225. Exhaust Muffler (2) @ Three-Way Catalytic Converter (3) » Separate

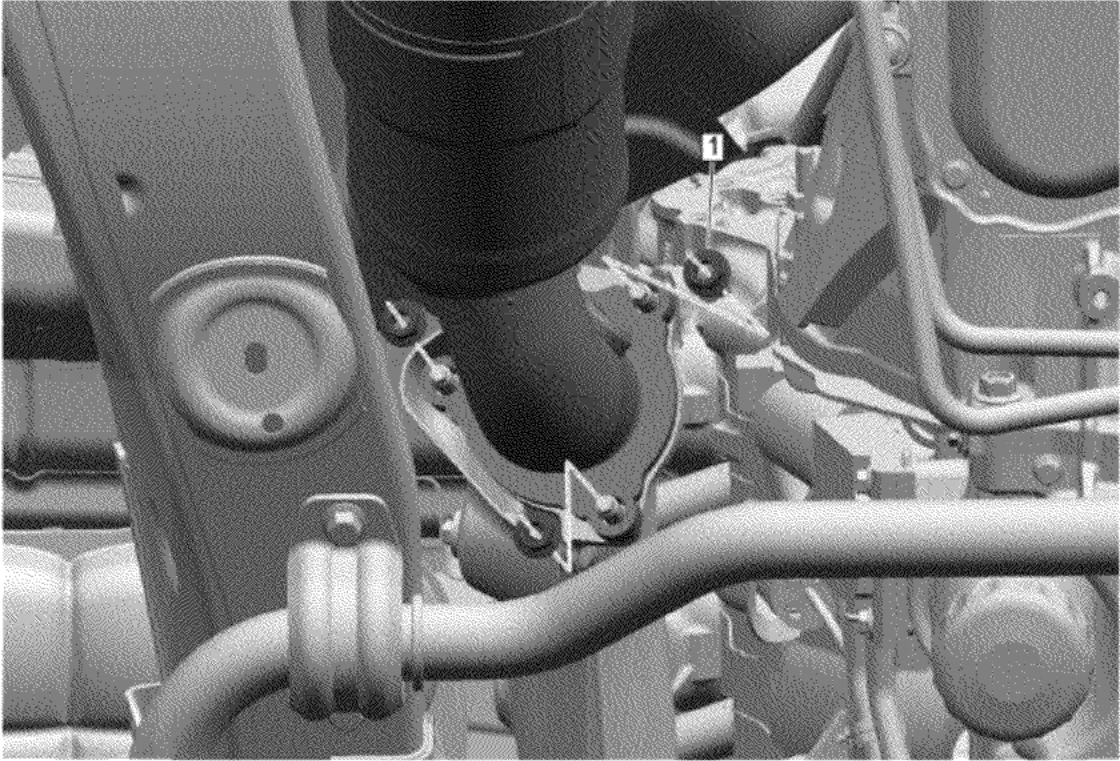

Warning: In order to avoid being burned, do not service the exhaust system while it is still hot. Service the system when it is cool.

226. Exhaust Front Pipe Nut - Left Side (1) » Remove [3x]

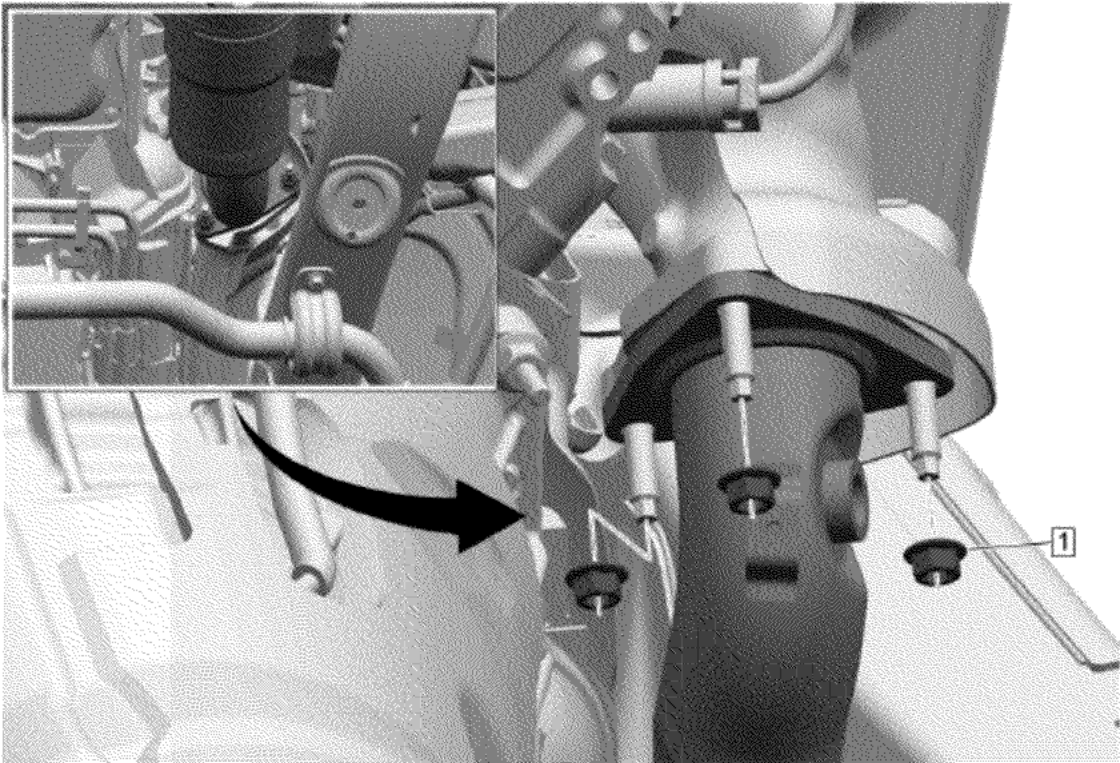

Warning: In order to avoid being burned, do not service the exhaust system while it is still hot. Service the system when it is cool.

227. Exhaust Front Pipe Nut - Right Side (1) » Remove [3x]

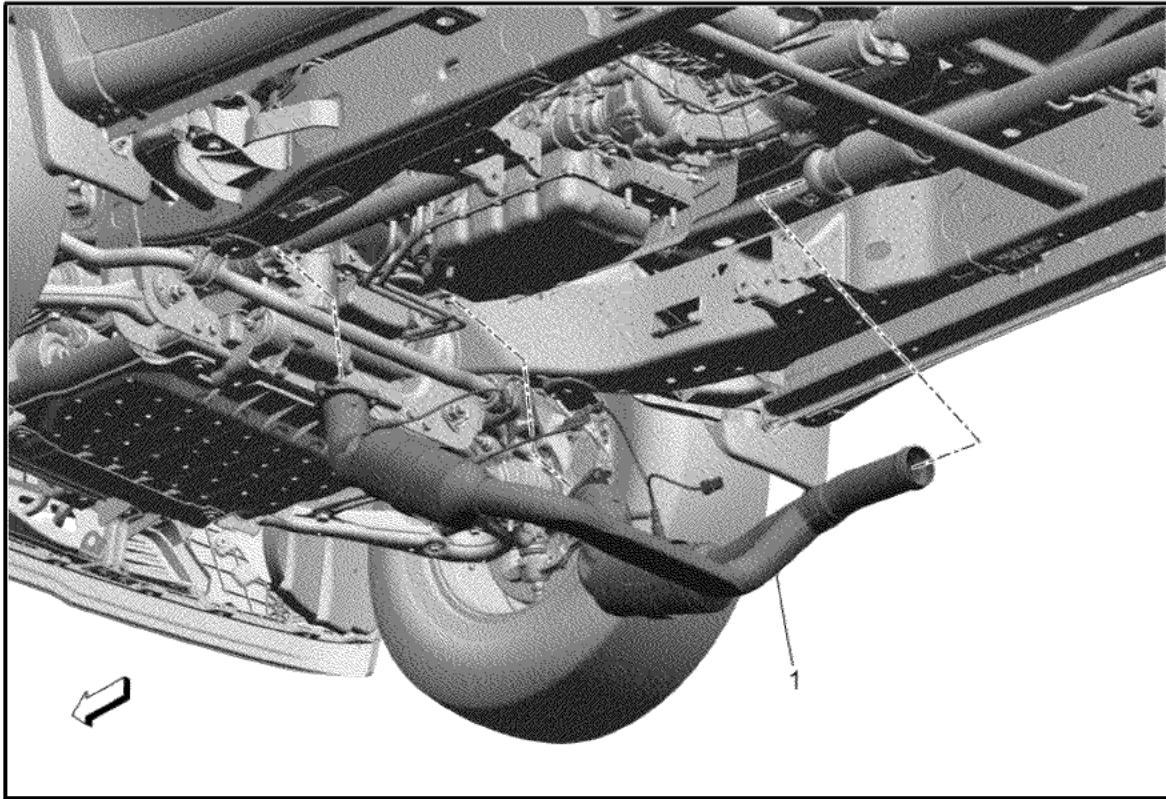

© 2025 General Motors. All rights reserved.



Warning: Avoid contact with HOT components. Wear safety glasses and protective gloves to avoid personal injury.

228. Three-Way Catalytic Converter (1) » Remove

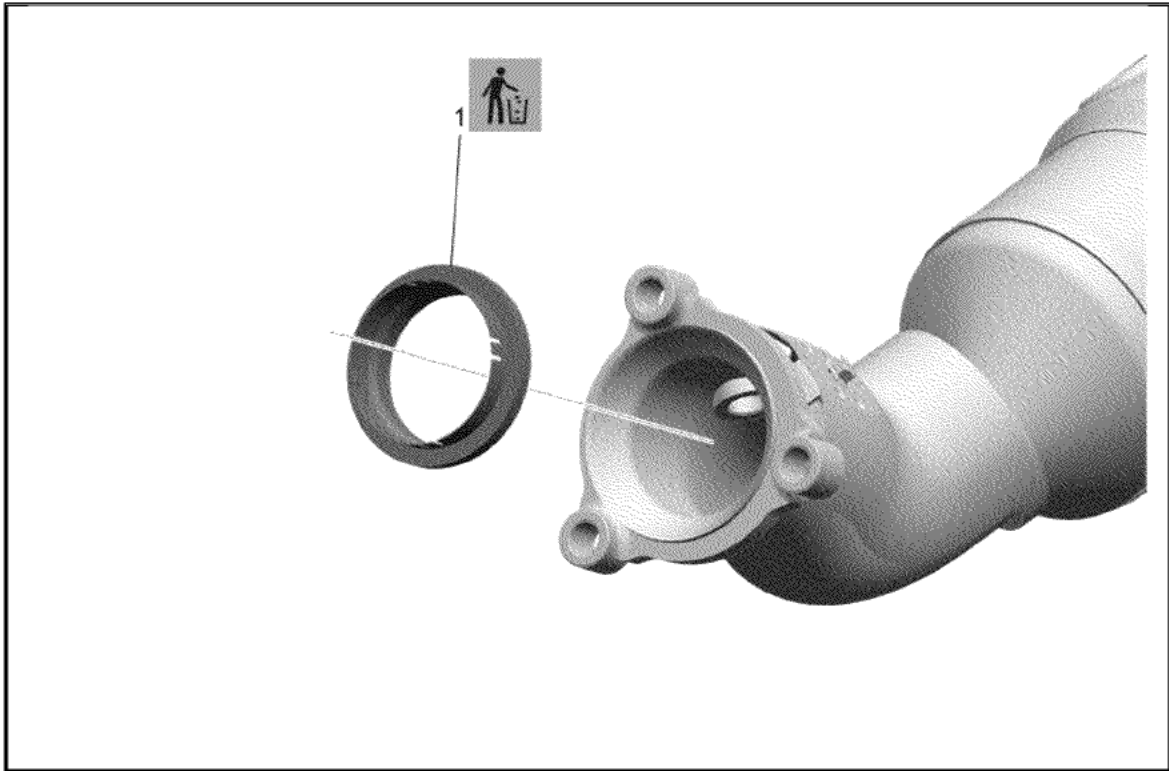

229. Exhaust System Seal (1) » Remove and DISCARD

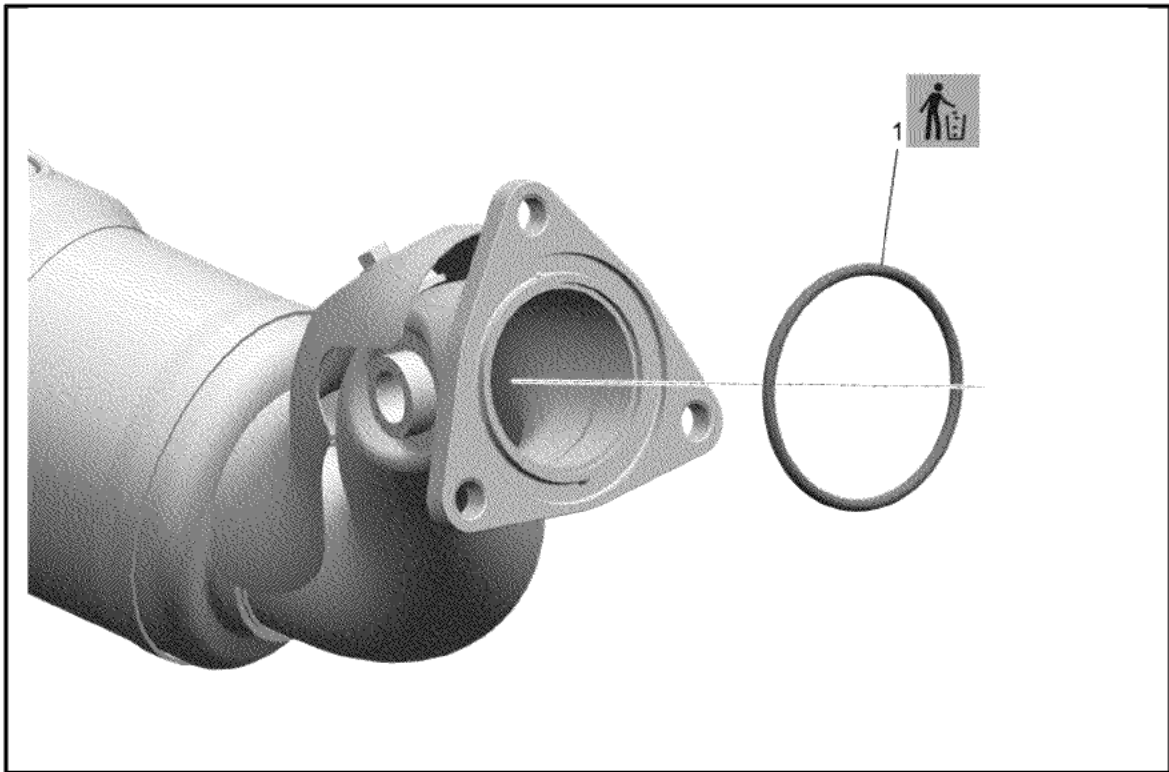

230. Exhaust System Seal (1) » Remove and DISCARD

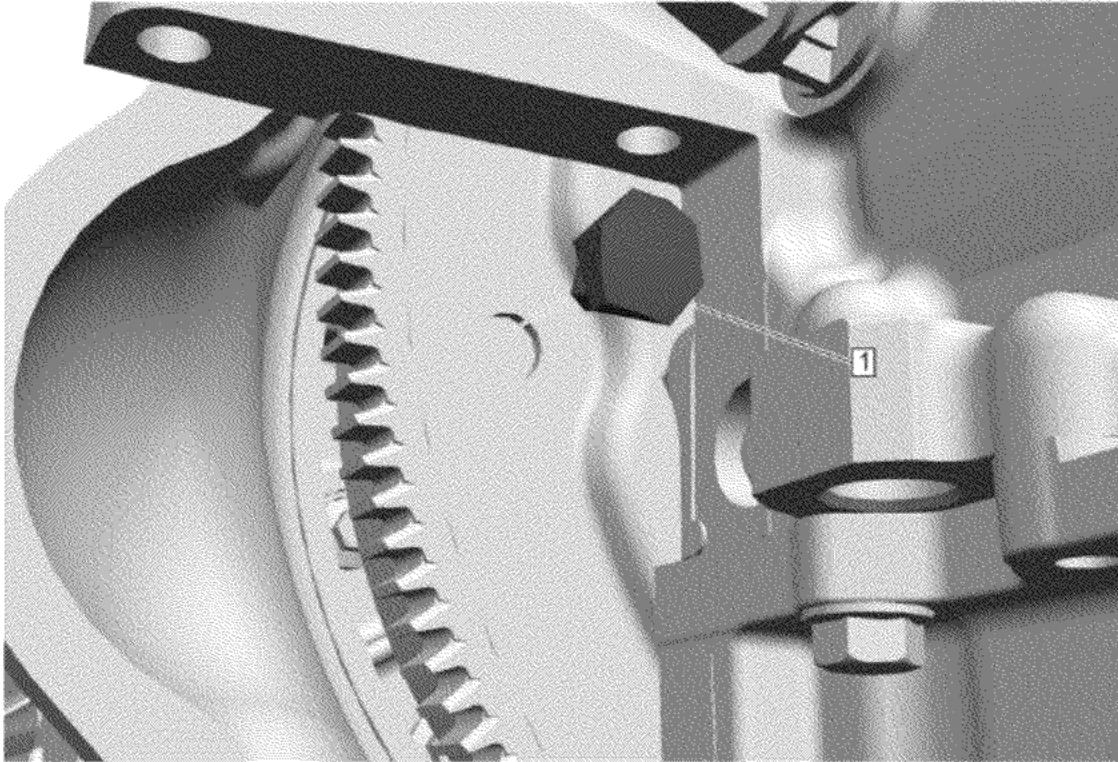

231. Repeat the following steps for all torque converter bolts (1):

231.1. Rotate the harmonic balancer center bolt clockwise ONLY, to align the torque converter bolt with the starter opening.

231.2. Torque Converter Bolt (1) » Remove [6x]

232. Lower the transmission to gain access to the top and sides of the transmission.

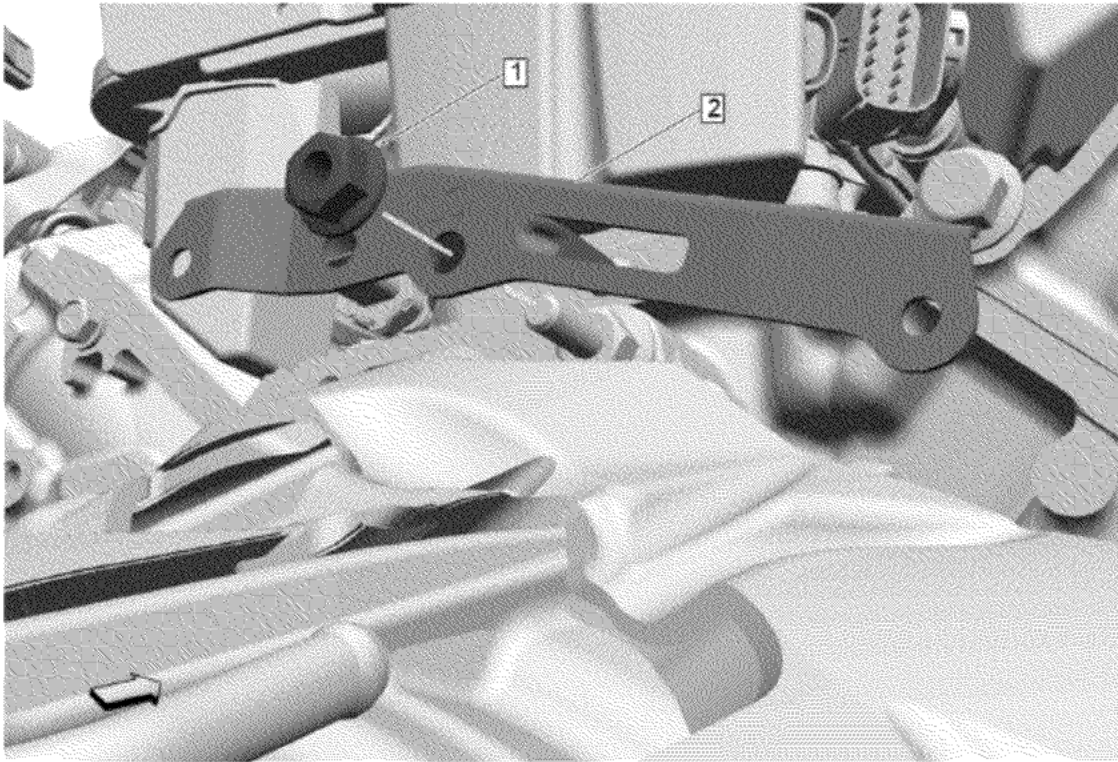

233. Remove the transmission vent hose clip bracket nut (1).

234. Remove the transmission vent hose clip bracket (2) from the transmission.

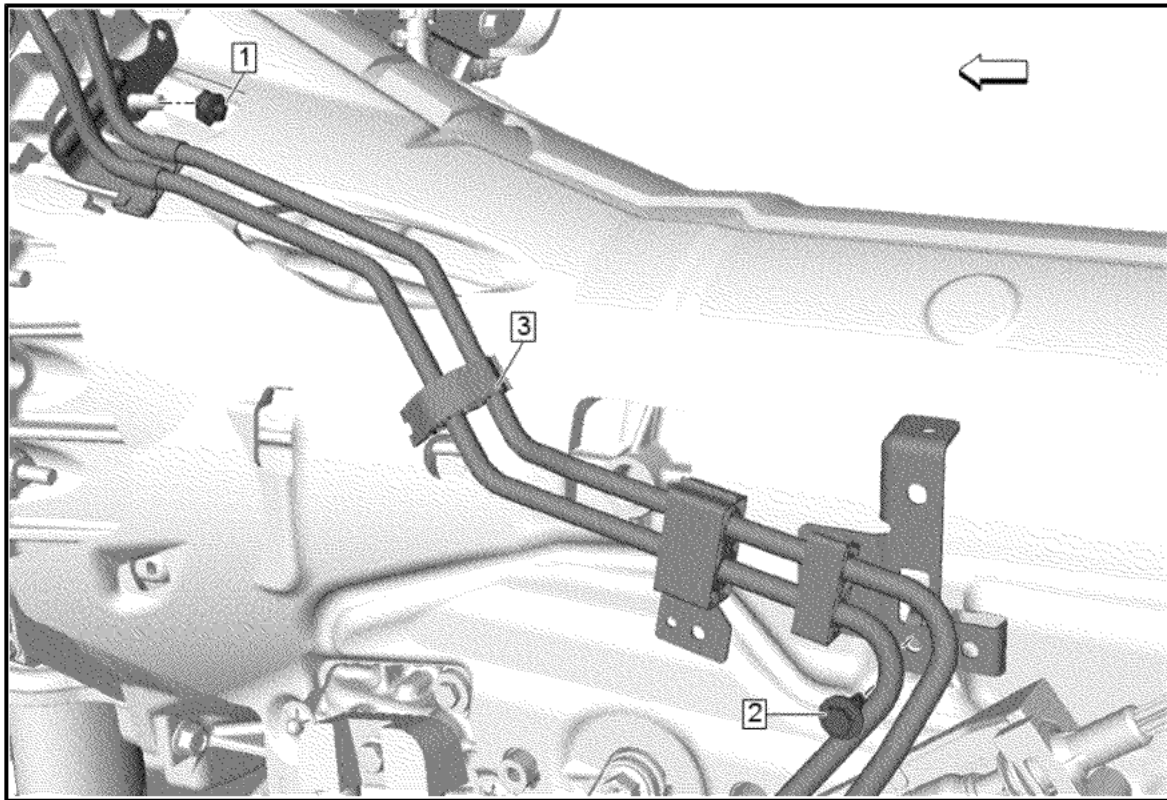

235. Remove the fuel feed and return front hose bracket nut (1).
236. Remove the fuel feed and return front hose bracket bolt (2).
237. Reposition the fuel feed and return front hose (3) as necessary.

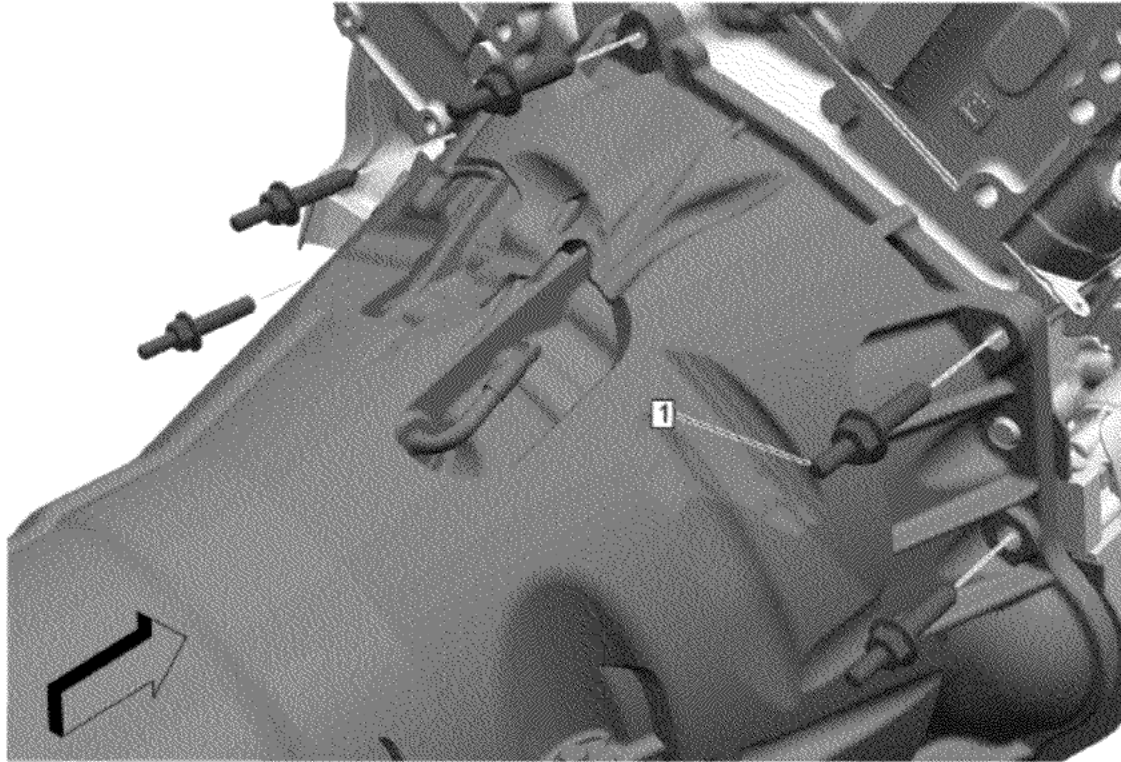

© 2025 General Motors. All rights reserved.

238. Transmission Stud (1) » Remove [5x]
239. Raise the transmission to the original installation position.

© 2025 General Motors. All rights reserved.

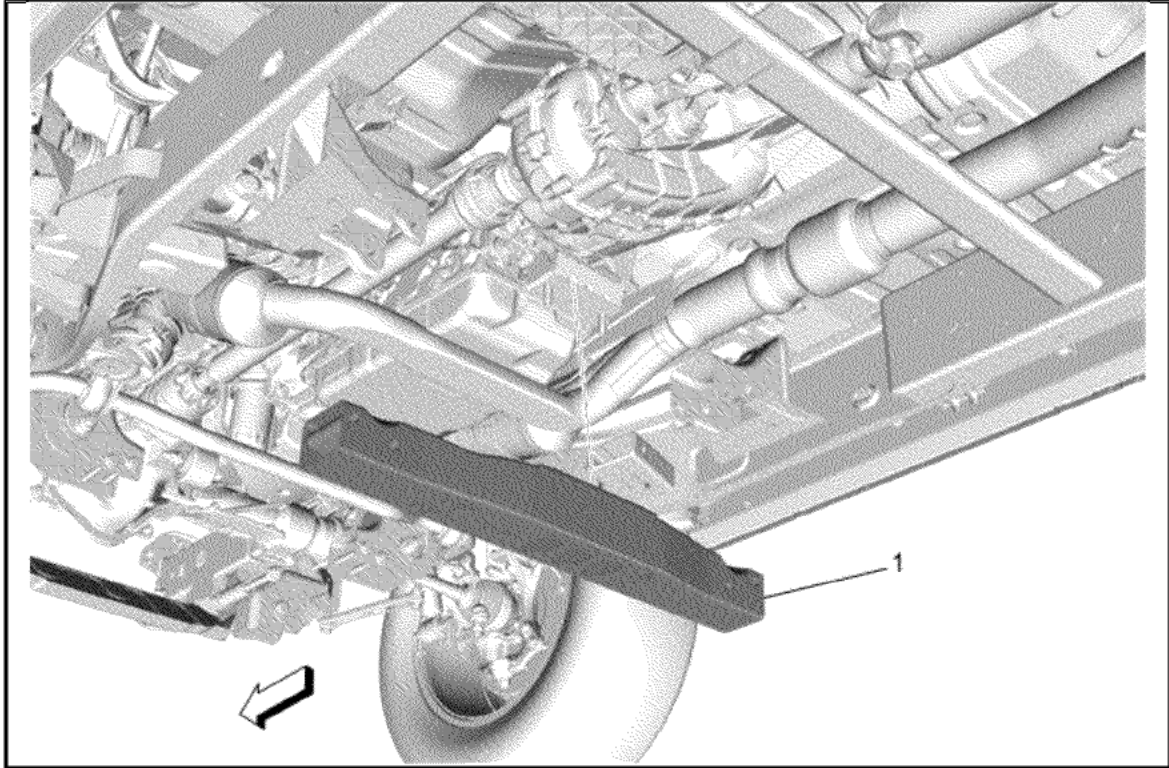

240. Transmission Support Crossmember (1) » Install

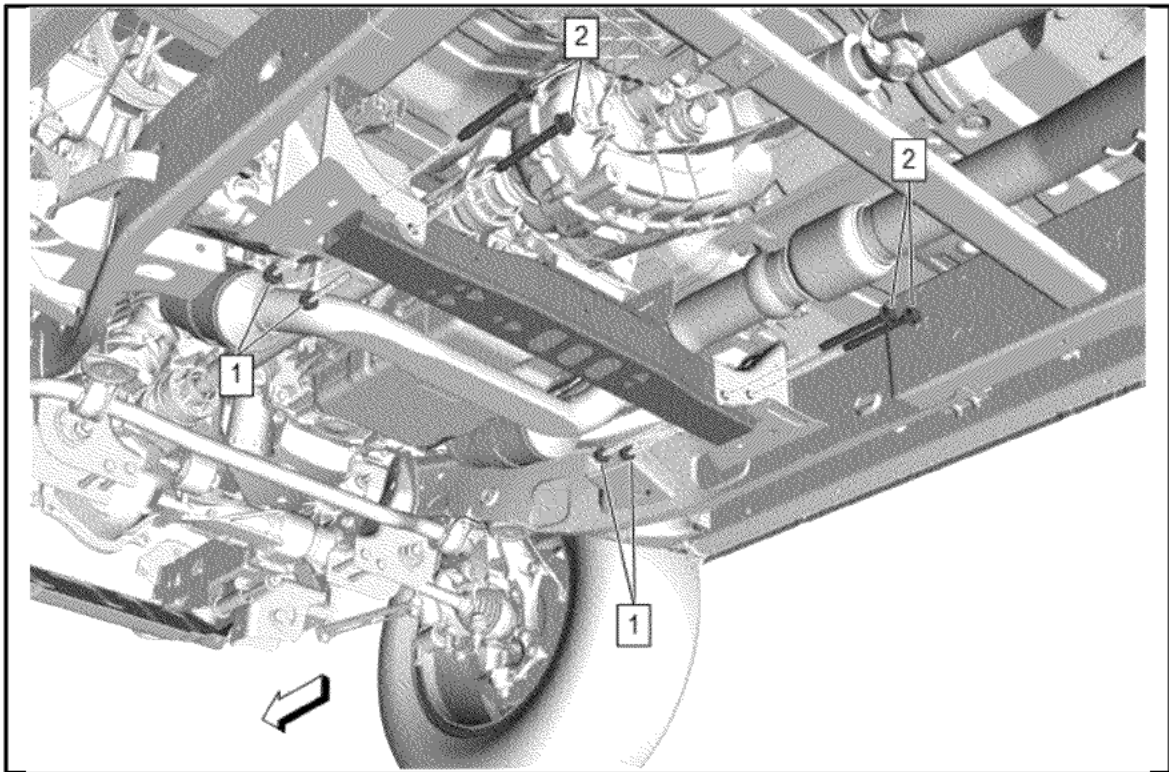

241. Transmission Support Crossmember Bolt (2) » Install [4x]

242. Transmission Support Crossmember Nut (1) » Install and hand tighten [4x]

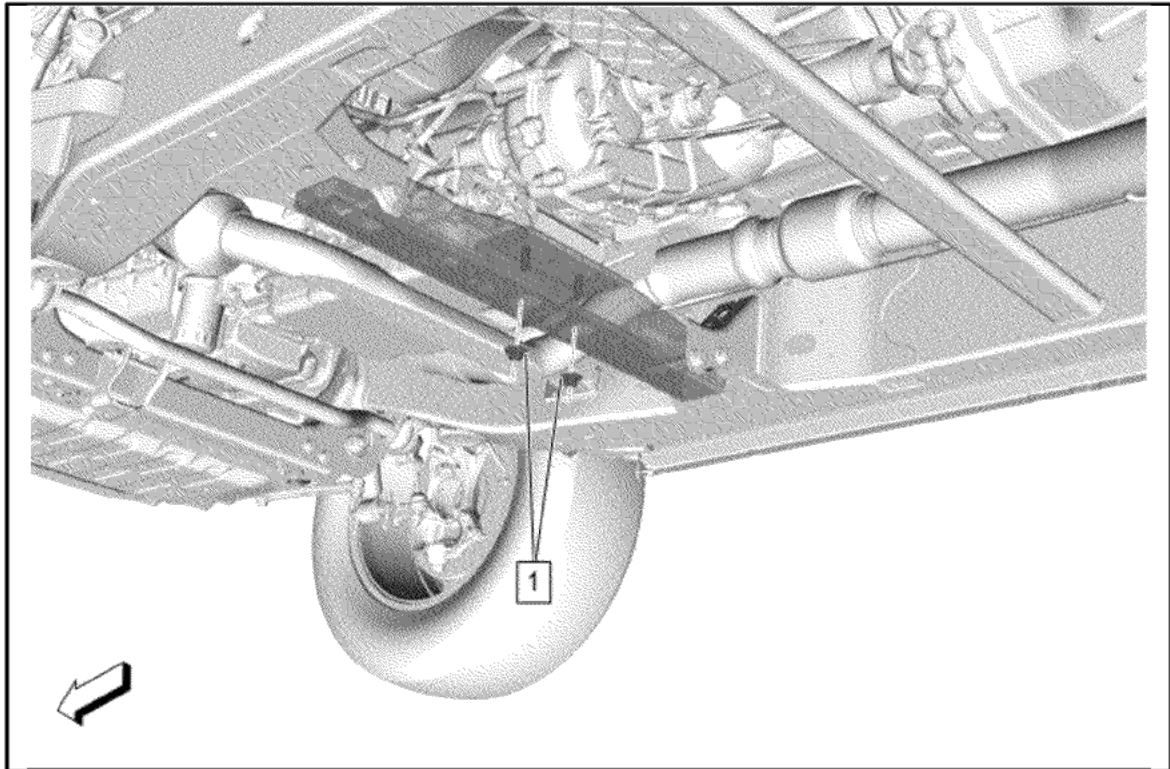

243. Transmission Mount Nut (1) » [Fastener Specifications](#) [2x]

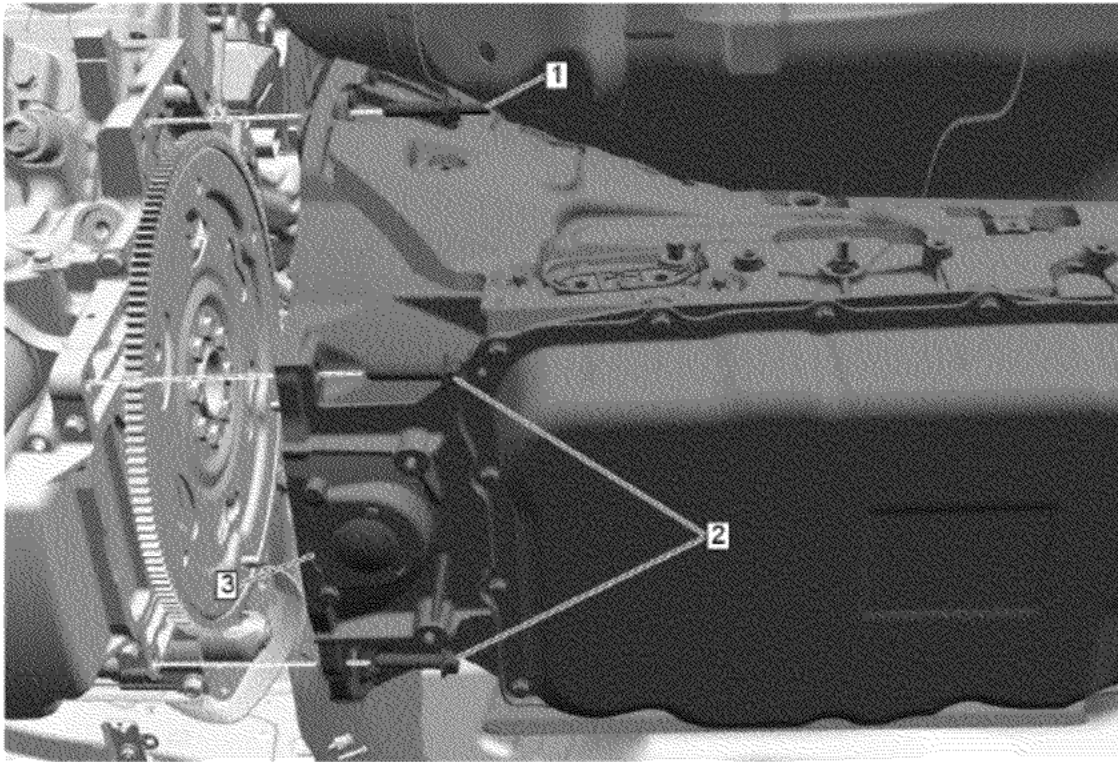

- 244. Transmission Stud (1) » Remove
- 245. Transmission Bolt (2) » Remove [2x]
- 246. Disconnect the electrical connectors from the transmission assembly, then position the wiring harness on the engine assembly.
- 247. Remove the support and lower the vehicle.

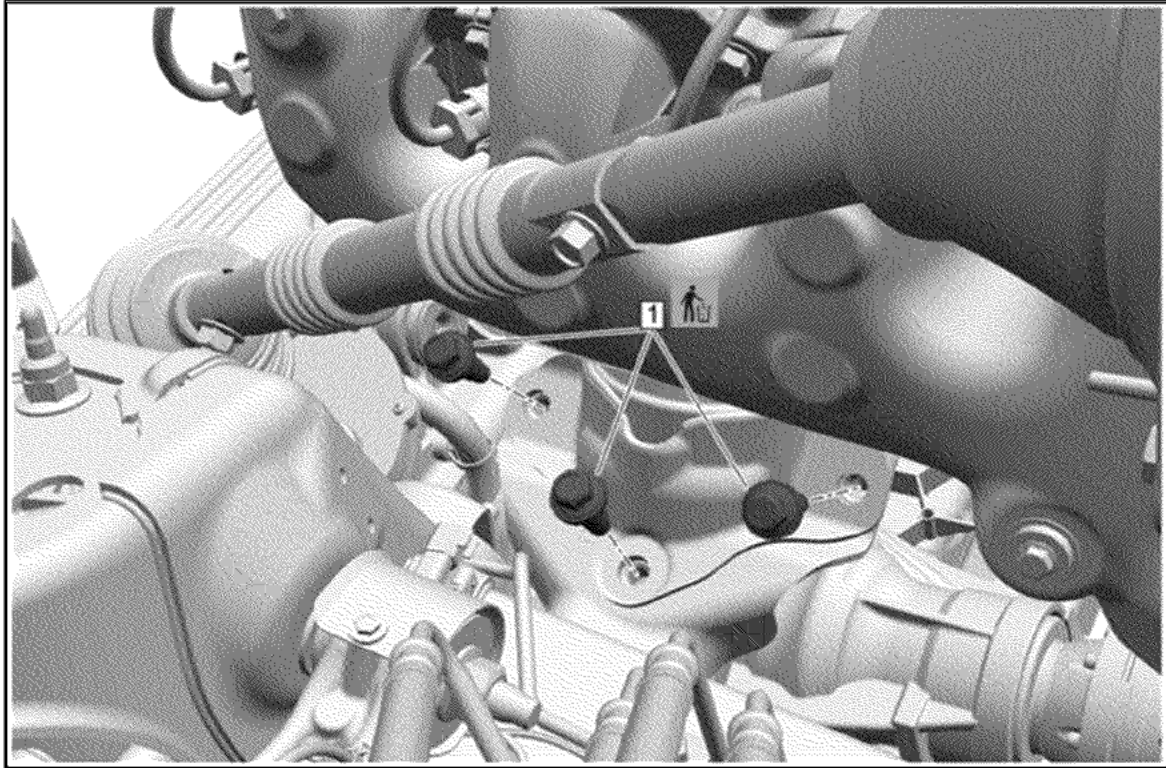

Caution: Broken engine mountings can cause misalignment of certain drive-train components. Misalignment of drive-train components causes eventual destruction of the drive-train components.
If one engine mount breaks, the rest of the engine mounts will have increased stress put on them. This could cause the rest of the engine mounts to break.

Note: Work through the front wheelhouse opening to access the 3 engine mount frame side bolts (1).

248. Engine Mount Frame Side Bolt - Left Side (1) » Remove and DISCARD [3x]

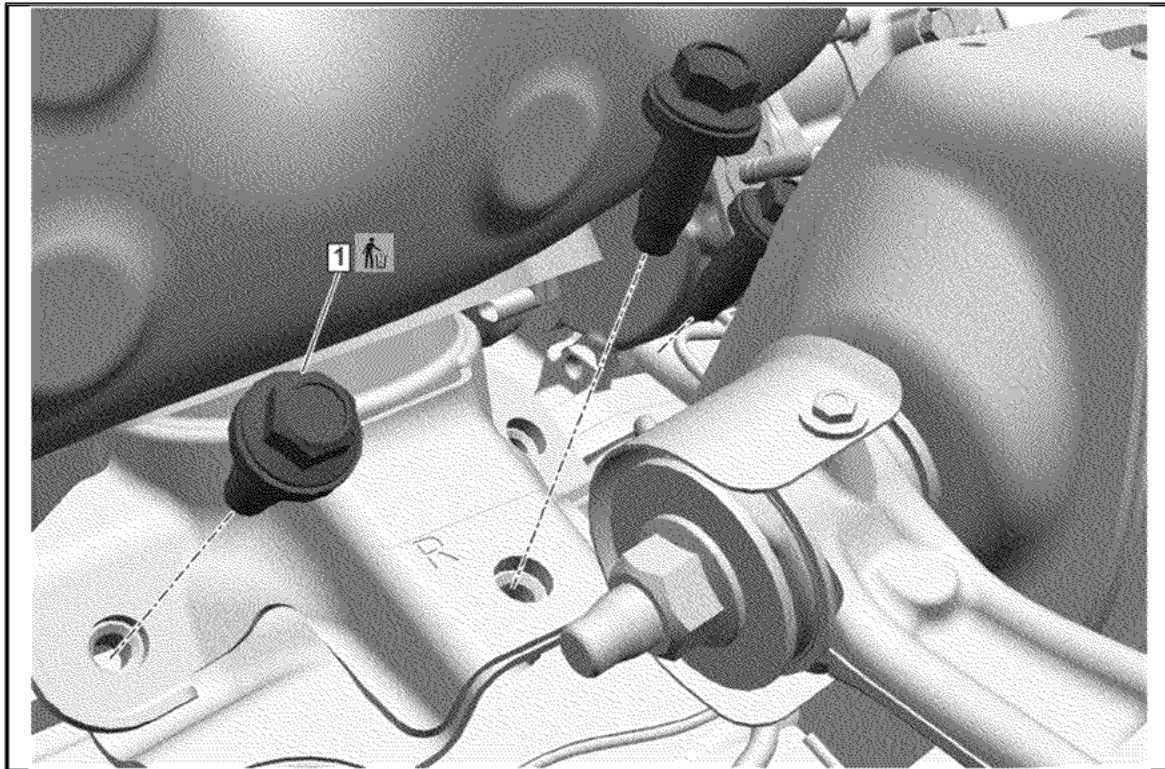

© 2025 General Motors. All rights reserved.

Caution: Broken engine mountings can cause misalignment of certain drive-train components. Misalignment of drive-train components causes eventual destruction of the drive-train components.
If one engine mount breaks, the rest of the engine mounts will have increased stress put on them. This could cause the rest of the engine mounts to break.

Note: Work through the front wheelhouse opening to access the 3 engine mount frame side bolts (1).

249. Engine Mount Frame Side Bolt - Right Side (1) » Remove and DISCARD [3x]
250. Install a suitable chain to the two engine lift brackets to support the engine.
251. Use a suitable stand to support the transmission.
252. Disconnect the remaining electrical connectors, retainers and reposition the wiring harness.
253. Using a suitable engine lifting device, remove the engine from the vehicle.

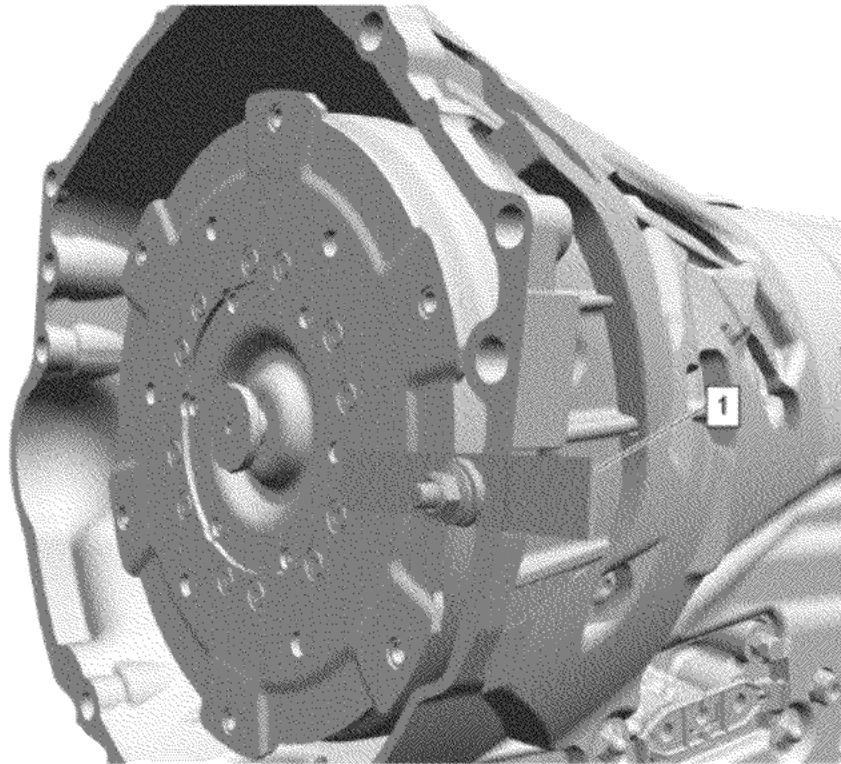

254. Install the *DT-21366* Converter Holding Strap (1) onto the transmission to retain the torque converter.

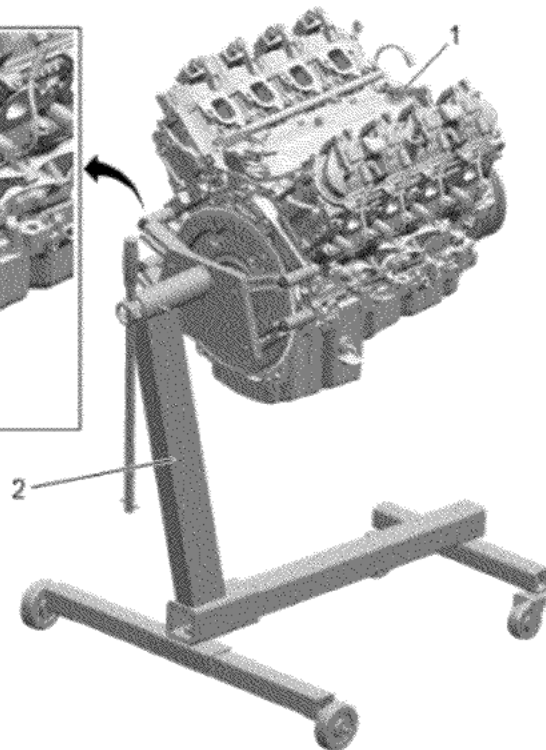
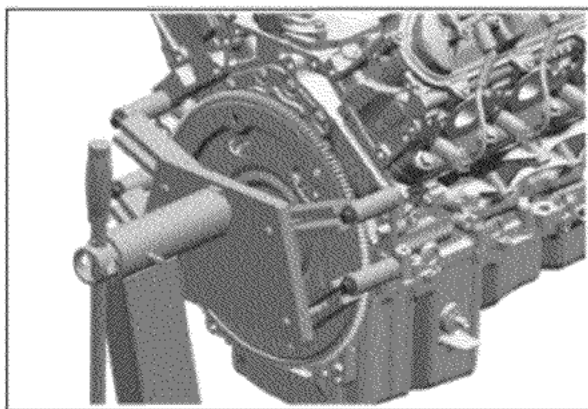

255. Mount the engine (1) onto the engine stand (2).

Cleaning and Inspection Procedure - Required

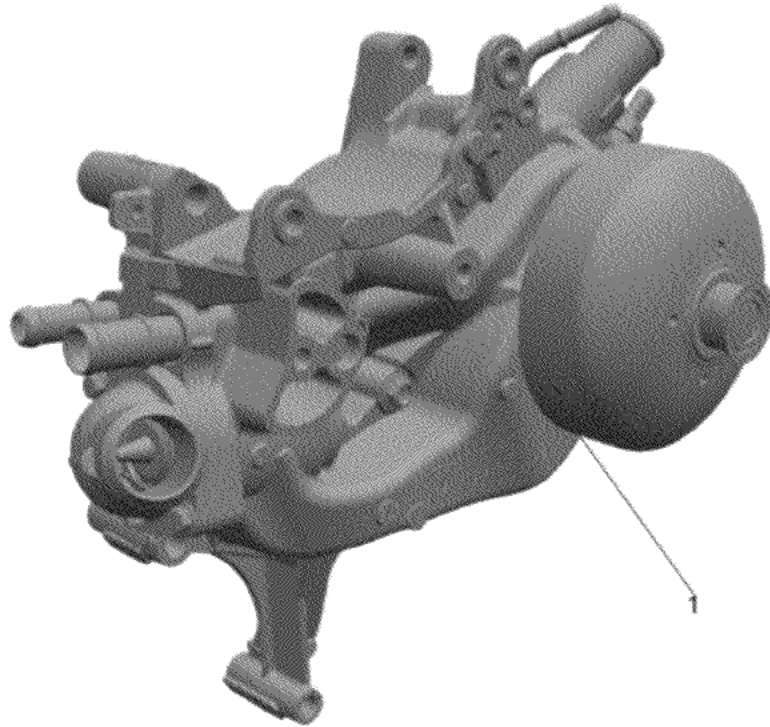

© 2025 General Motors. All rights reserved.

1. Clean all excess dirt and debris from the water pump (1).
2. Inspect the water pump (1) for the following conditions:
 - 2.1. Water pump gasket and hose sealing surfaces for excessive scratches or gouging
 - 2.2. Restrictions within the internal coolant passages
 - 2.3. Excessive side-to-side play in the pulley shaft
 - 2.4. Leakage at the water inlet housing or rear cover
 - 2.5. Leakage at the water outlet housing or water pump outlet
 - 2.6. Leakage at the water pump vent hole
A stain around the vent hole is acceptable. If leakage or dripping occurs with the engine running and the cooling system pressurized, replace the water pump (1).
 - 2.7. Wear or damage in the belt tracking area of the water pump pulley

Cleaning and Inspection Procedure - Conditional

Note: The following cleaning and inspection and/or overhaul steps are ONLY to be performed as determined necessary based on the condition of the part being removed with the intention of reinstallation.

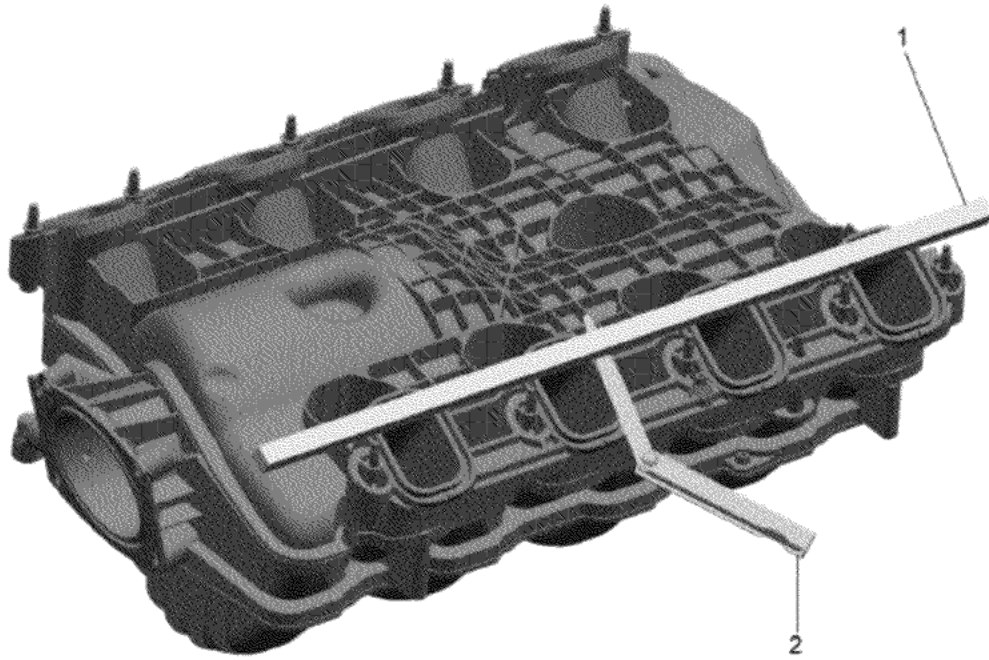

© 2025 General Motors. All rights reserved.

1. Clean all sealing surfaces.
2. Dry the intake manifold with compressed air.
3. Inspect the intake manifold cylinder head deck for warpage.
4. Place a straight edge (1) across the intake manifold cylinder head deck surface.
5. Inspect the intake manifold for the following conditions:
 - 5.1. Inspect for loose threaded inserts or studs.
 - 5.2. Inspect for damaged or broken vacuum fitting.
 - 5.3. Inspect the intake manifold assembly for cracks or other damage.
 - 5.4. Inspect for damaged intake manifold gasket sealing surfaces.
6. Position the straight edge (1) across a minimum of two runner port openings and check for warpage using a feeler gage. [Engine Mechanical Specifications](#)
7. Inspect the ventilation system passages for restrictions.

Installation Procedure

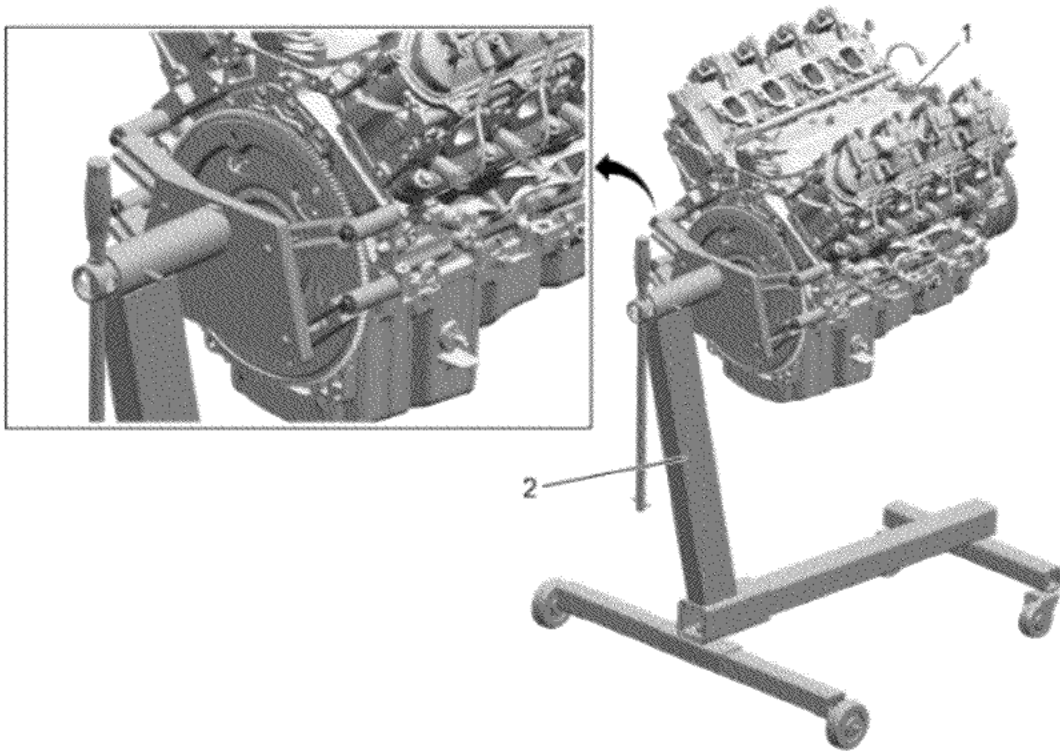

1. Using a suitable engine lifting device, remove the engine (1) from the engine stand (2).

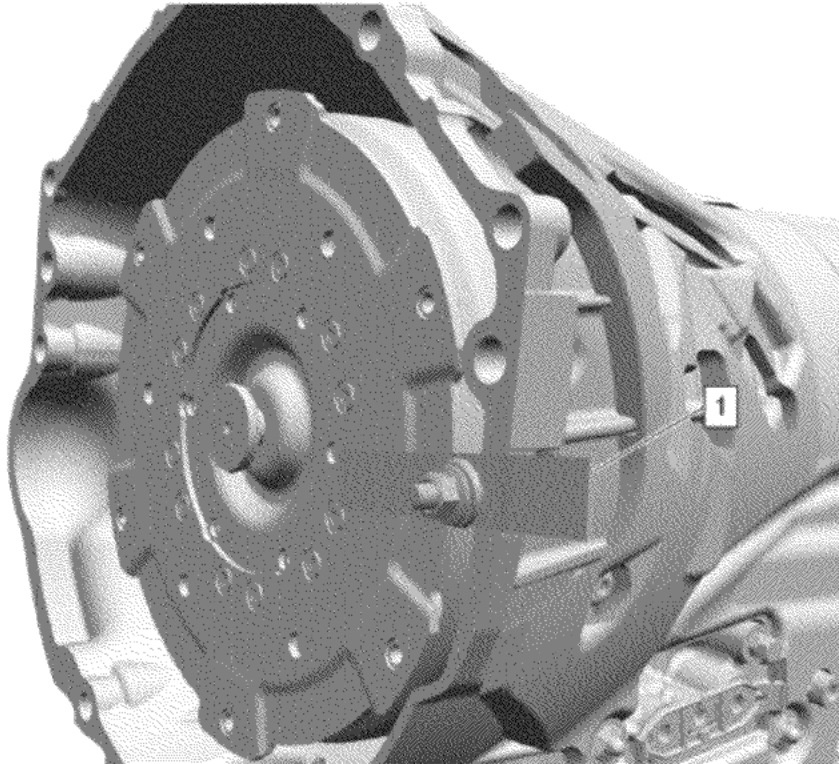

2. Remove the *DT-21366* Converter Holding Strap (1) from the transmission which is retaining the torque converter.

3. Position the engine to the transmission assembly.

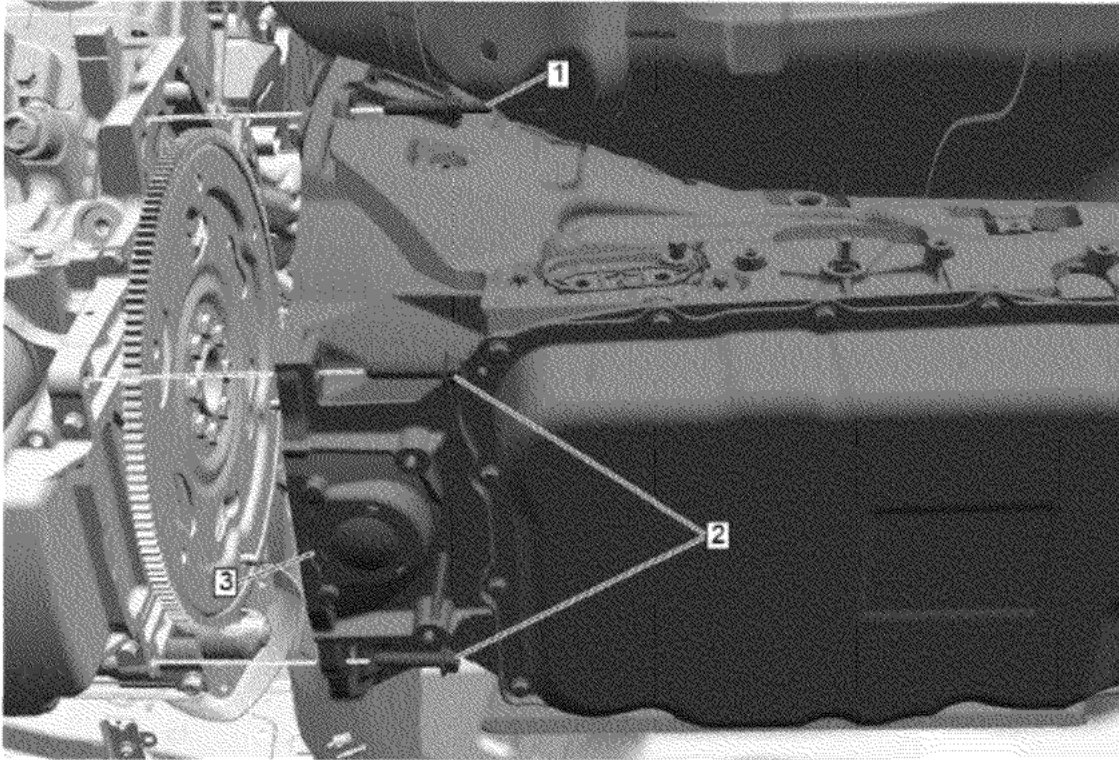

4. Transmission Bolt (2) » Install and tighten [2x] — [Fastener Specifications](#)
5. Transmission Stud (1) » Install and tighten — [Fastener Specifications](#)
6. Connect the required electrical connectors, retainers and reposition the wiring harness.

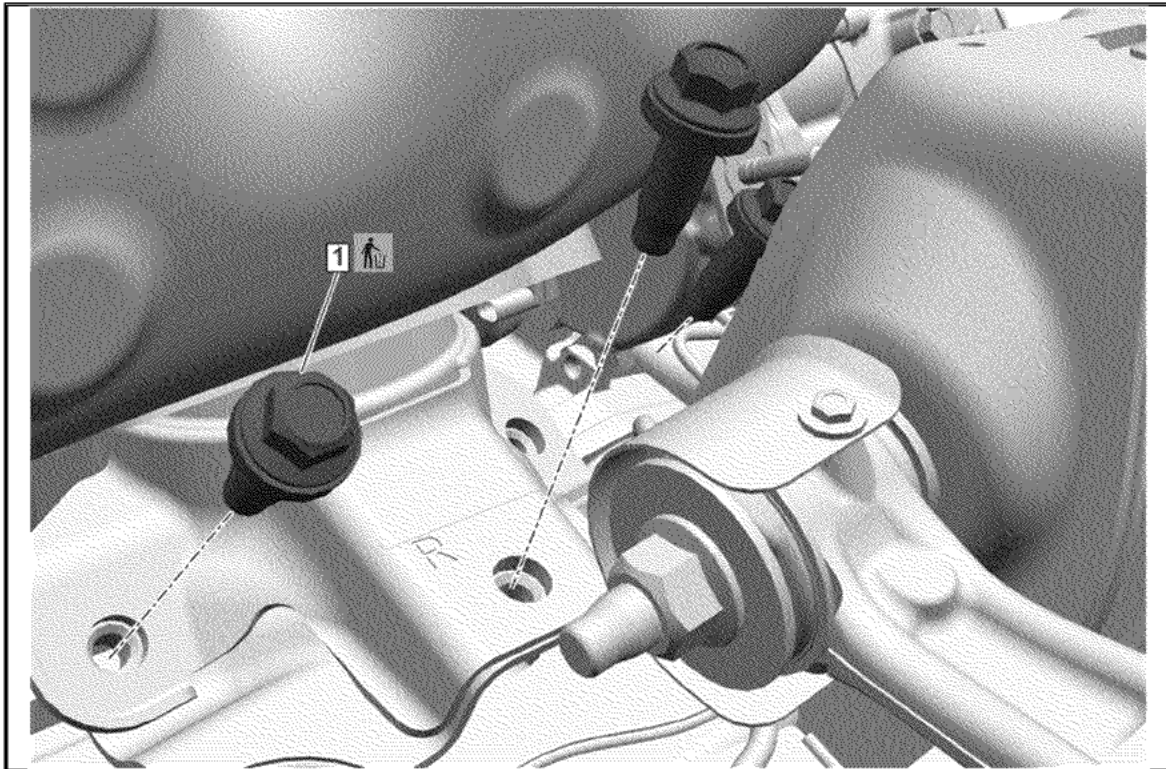

7. If NEW threaded components are being installed, loosen the adhesive using a metal pick or similar tool before proceeding. If threaded components are reused, prepare the threaded components using the following steps:
 - 7.1. Remove any loose cured adhesive from the external threads of the components using a lint free cloth.
 - 7.2. Thread the cleaned components into the internal mating threads and remove to loosen trapped cured adhesive.
 - 7.3. Apply thread locking adhesive to the external threads of the components. [Adhesives, Fluids, Lubricants, and Sealers](#)
 - 7.4. Ensure there are no gaps in the thread locking adhesive once applied to the component.
8. Engine Mount Frame Side Bolt - Right Side (1) » Install NEW and hand tighten [3x]
9. Engine Mount Frame Side Bolt - Right Side (1) » Tighten in sequence [3x] — [Fastener Specifications](#)

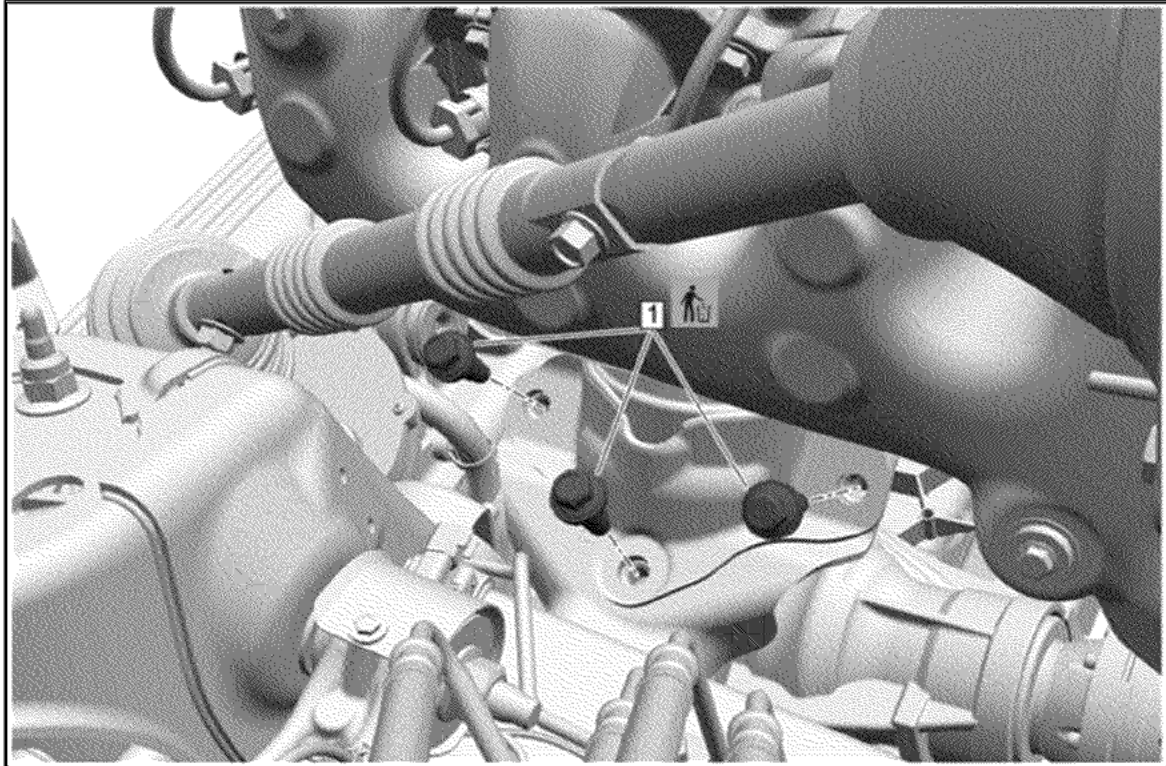

10. If NEW threaded components are being installed, loosen the adhesive using a metal pick or similar tool before proceeding. If threaded components are reused, prepare the threaded components using the following steps:
 - 10.1. Remove any loose cured adhesive from the external threads of the component using a lint free cloth.
 - 10.2. Thread the cleaned component into the internal mating threads and remove to loosen trapped cured adhesive.
 - 10.3. Apply thread locking adhesive to the external threads of the component. [Adhesives, Fluids, Lubricants, and Sealers](#)
 - 10.4. Ensure there are no gaps in the thread locking adhesive once applied to the component.
11. Engine Mount Frame Side Bolt - Left Side (1) » Install NEW and hand tighten [3x]
12. Engine Mount Frame Side Bolt - Left Side (1) » Tighten in sequence [3x] — [Fastener Specifications](#)
13. Remove the engine lift and chains that are supporting the engine.

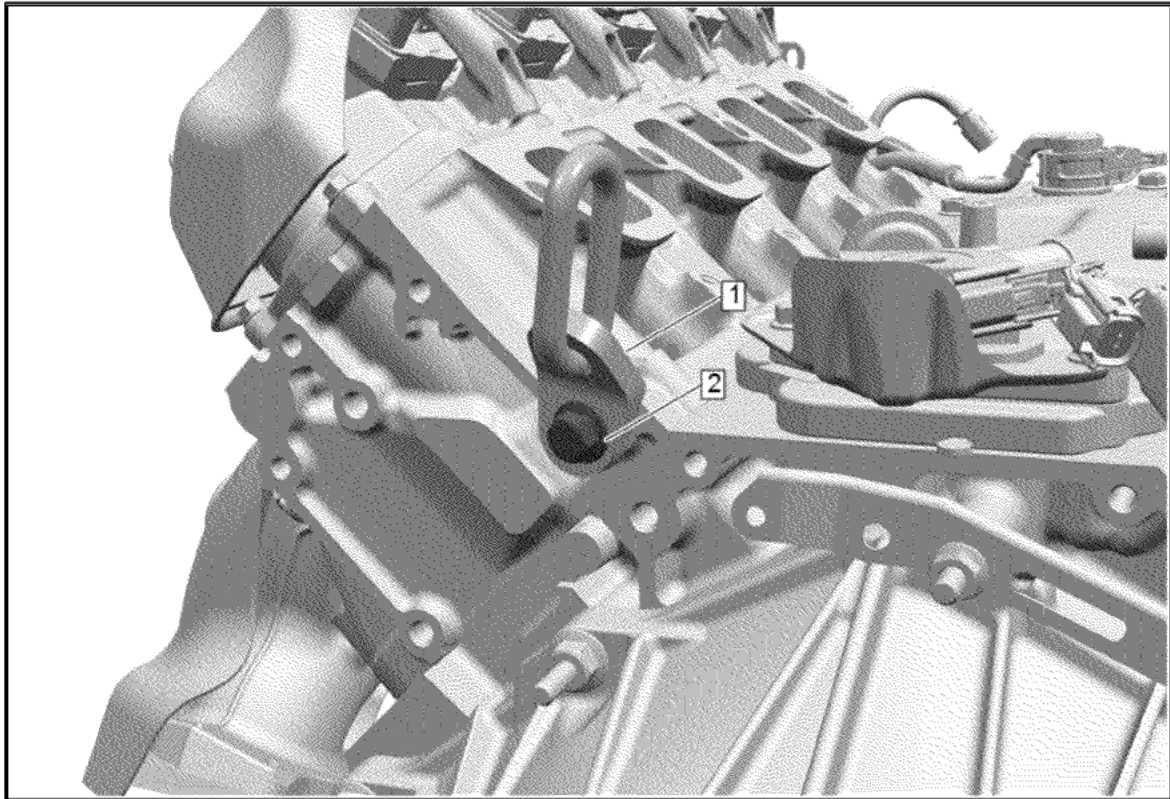

14. Remove the *EN-36857* Engine Lift Bracket (1) and the *EN-52059* Engine Support Fixture Adapter Bolt - M10 (2) from the cylinder head.

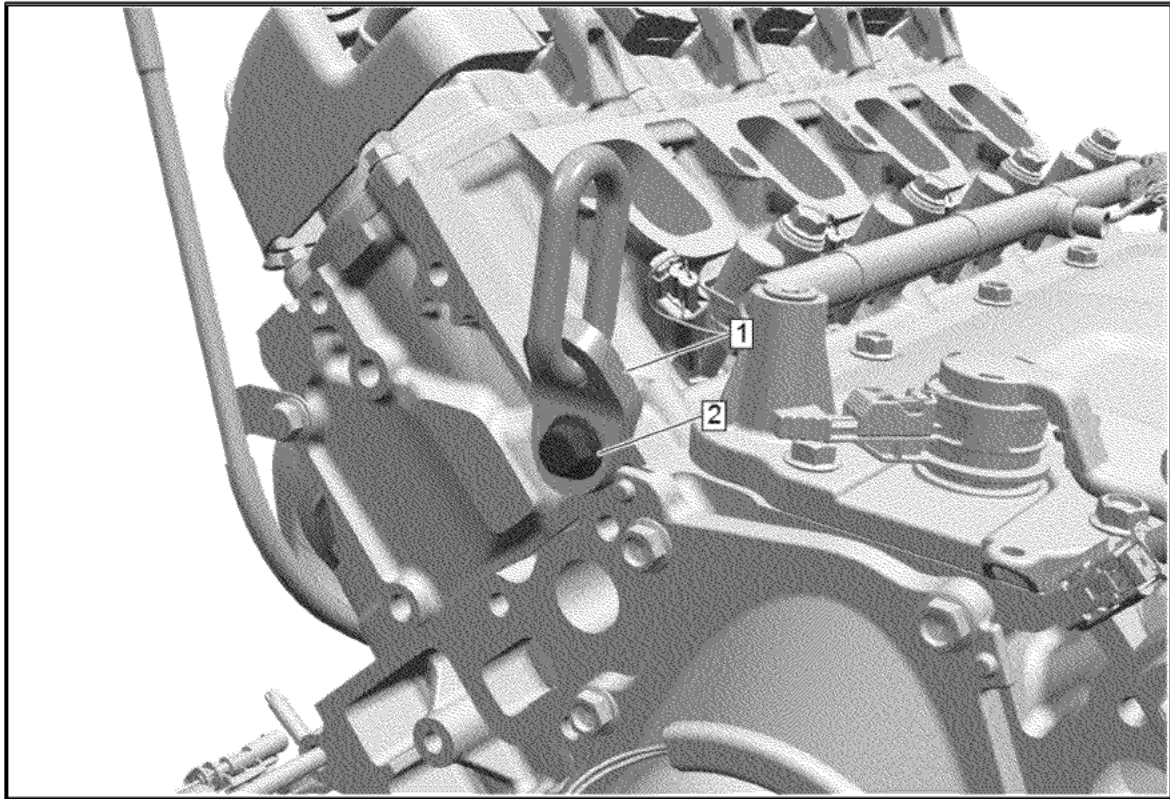

15. Remove the *EN-36857* Engine Lift Bracket (1) and the *EN-52059* Engine Support Fixture Adapter Bolt - M10 (2) from the cylinder head.
16. Support the transmission with a suitable jack.

© 2025 General Motors. All rights reserved.

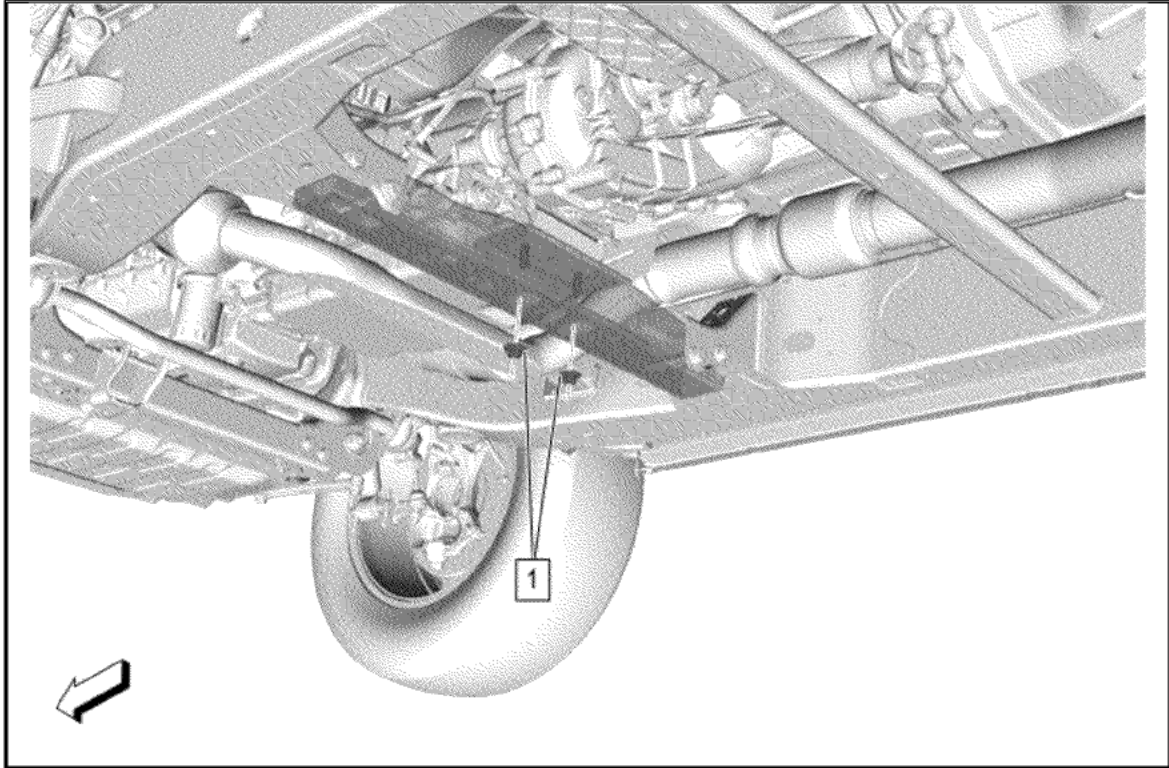

17. Transmission Mount Nut (1) » Remove [2x]

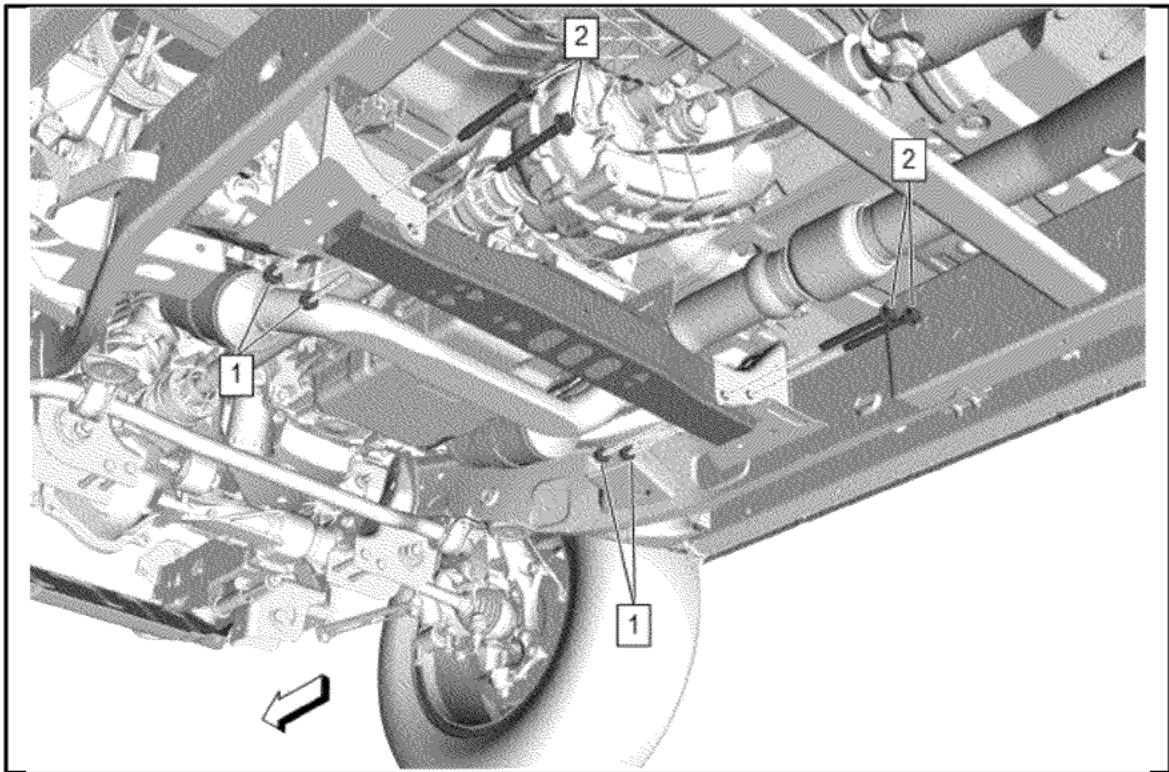

18. Transmission Support Crossmember Nut (1) » Remove [4x]

19. Transmission Support Crossmember Bolt (2) » Remove [4x]

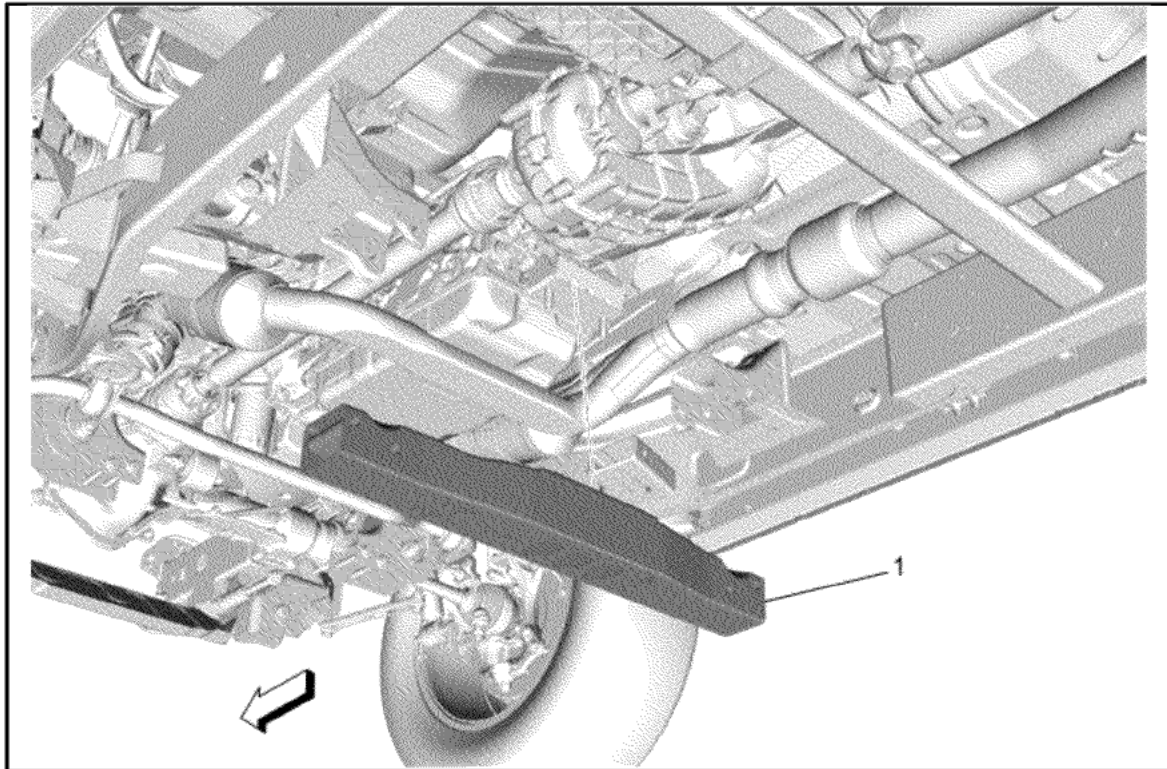

© 2025 General Motors. All rights reserved.

20. Transmission Support Crossmember (1) » Remove

21. Lower the transmission to gain access to the top of the transmission.

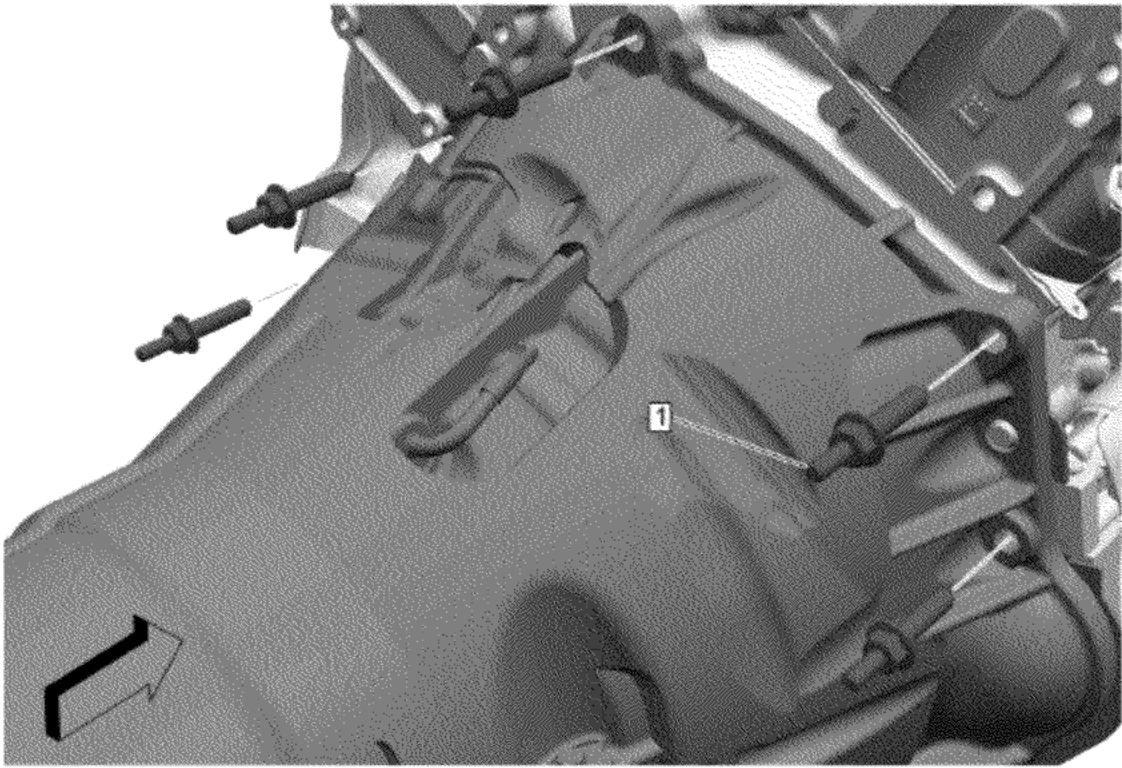

22. Transmission Stud (1) » Install and tighten [5x] — [Fastener Specifications](#)

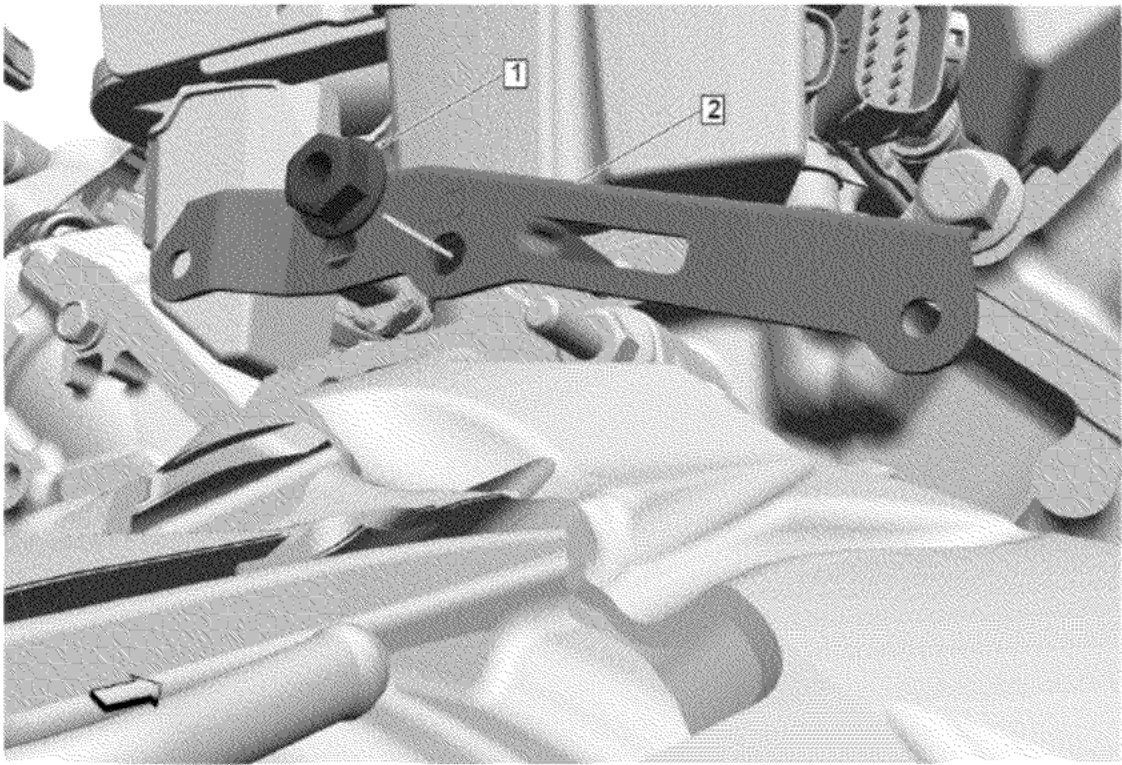

23. Install the transmission vent hose clip bracket (2) to the transmission.

24. Install and tighten the transmission vent hose clip bracket nut (1). [Fastener Specifications](#)

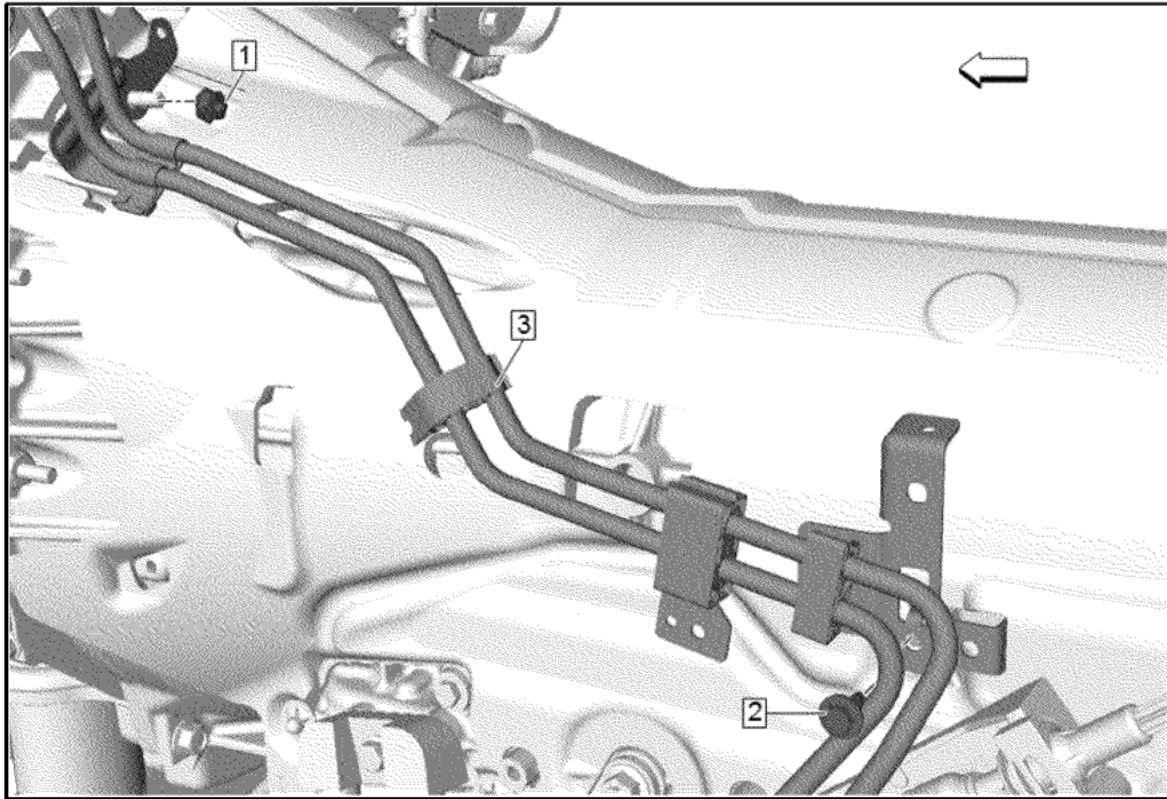

25. Install the fuel feed line assembly (3) on the transmission stud.
26. Install and tighten the fuel feed and return front hose bracket nut (1). [Fastener Specifications](#)
27. Install and tighten the fuel feed and return front hose bracket bolt (2). [Fastener Specifications](#)
28. Install and connect the transmission electrical harness connector retainers and electrical connectors.

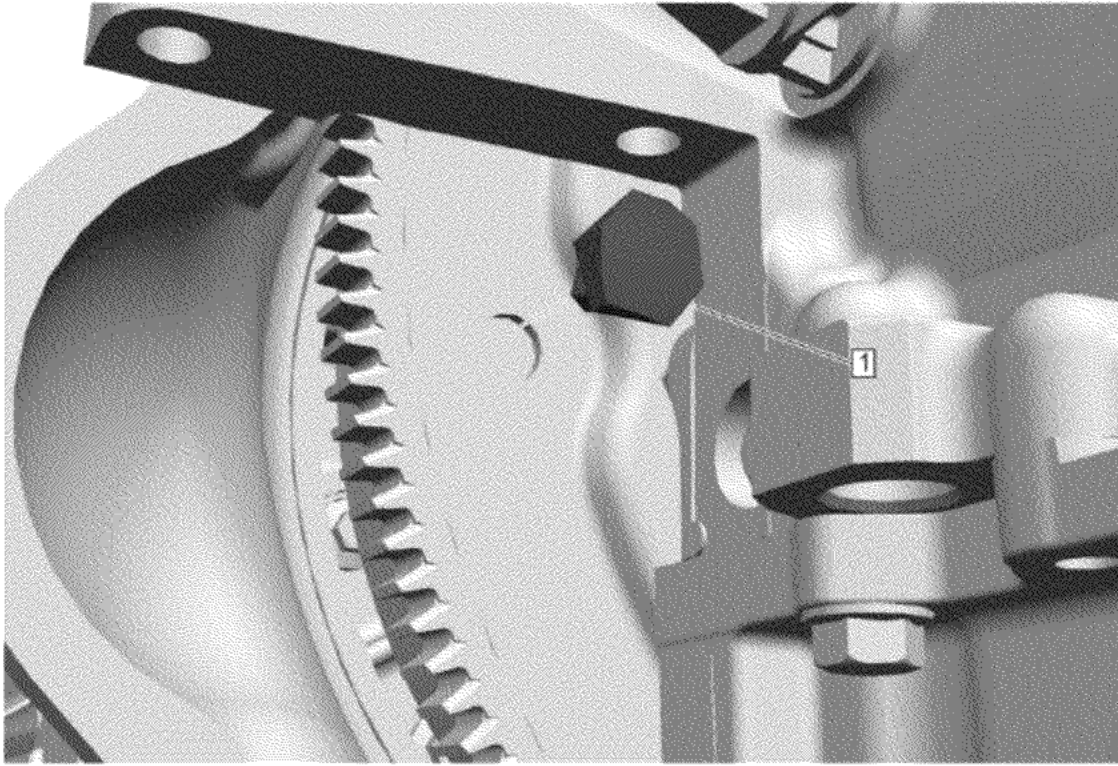

29. If NEW threaded components are being installed, loosen the adhesive using a metal pick or similar tool before proceeding. If threaded components are reused, prepare the threaded components using the following steps:
- 29.1. Remove any loose cured adhesive from the external threads of the components using a lint free cloth.
 - 29.2. Thread the cleaned components into the internal mating threads and remove to loosen trapped cured adhesive.
 - 29.3. Apply thread locking adhesive to the external threads of the components. [Adhesives, Fluids, Lubricants, and Sealers](#)
 - 29.4. Ensure there are no gaps in the thread locking adhesive once applied to the component.

Note:

- For proper alignment of all torque converter bolts, install the first torque converted bolt in the oval shaped hole.
- Rotate the harmonic balancer center bolt clockwise ONLY, to align the torque converter bolt with the starter opening.

30. Torque Converter Bolt (1) » Install and tighten [6x] — [Fastener Specifications](#)

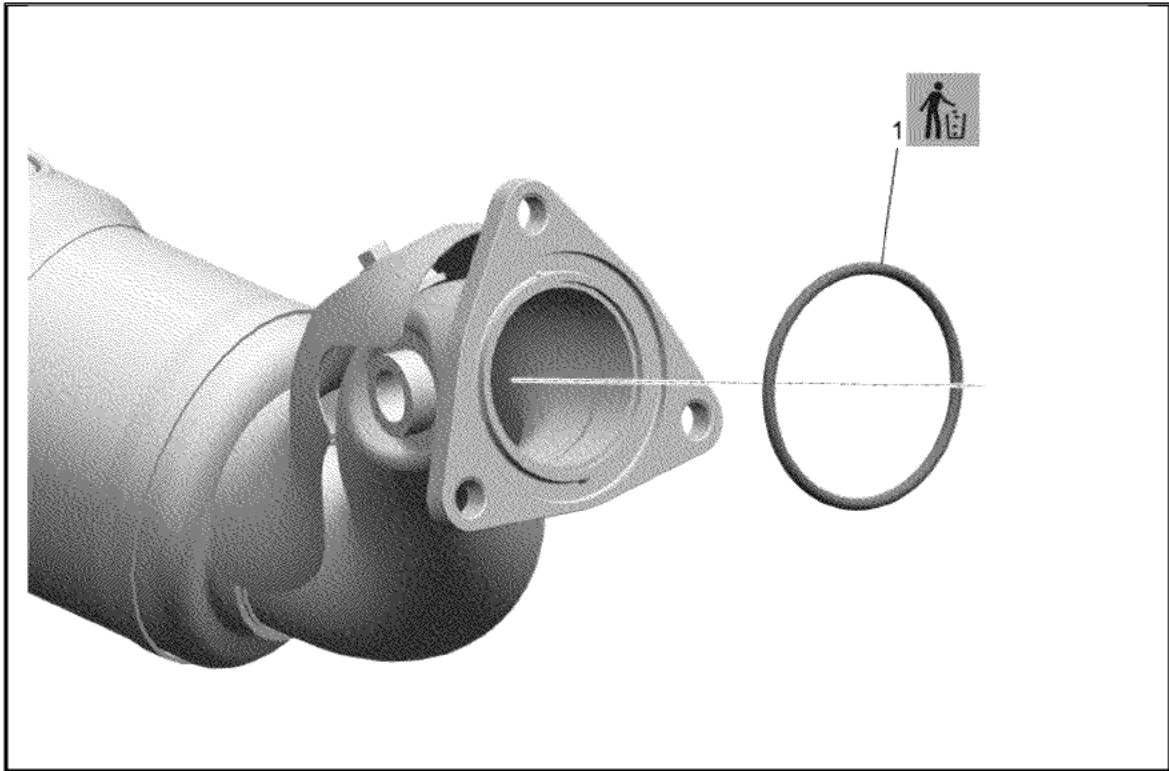

31. Exhaust System Seal (1) » Install NEW

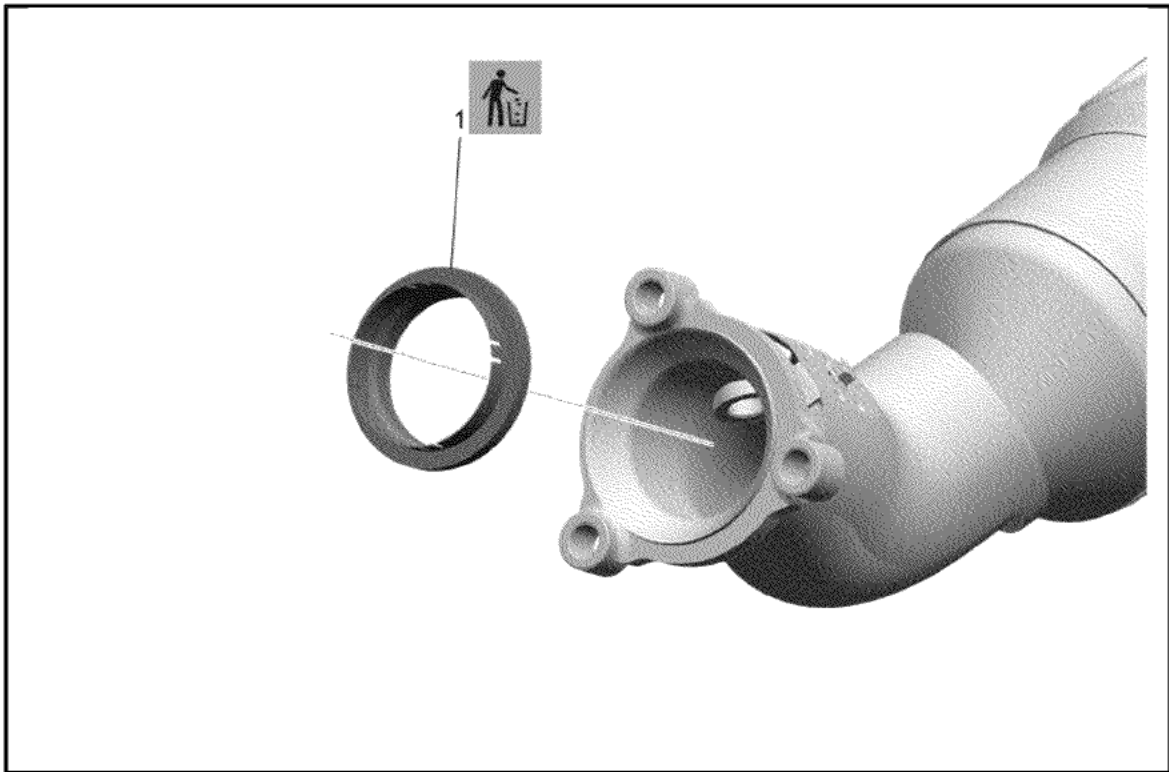

32. Exhaust System Seal (1) » Install NEW

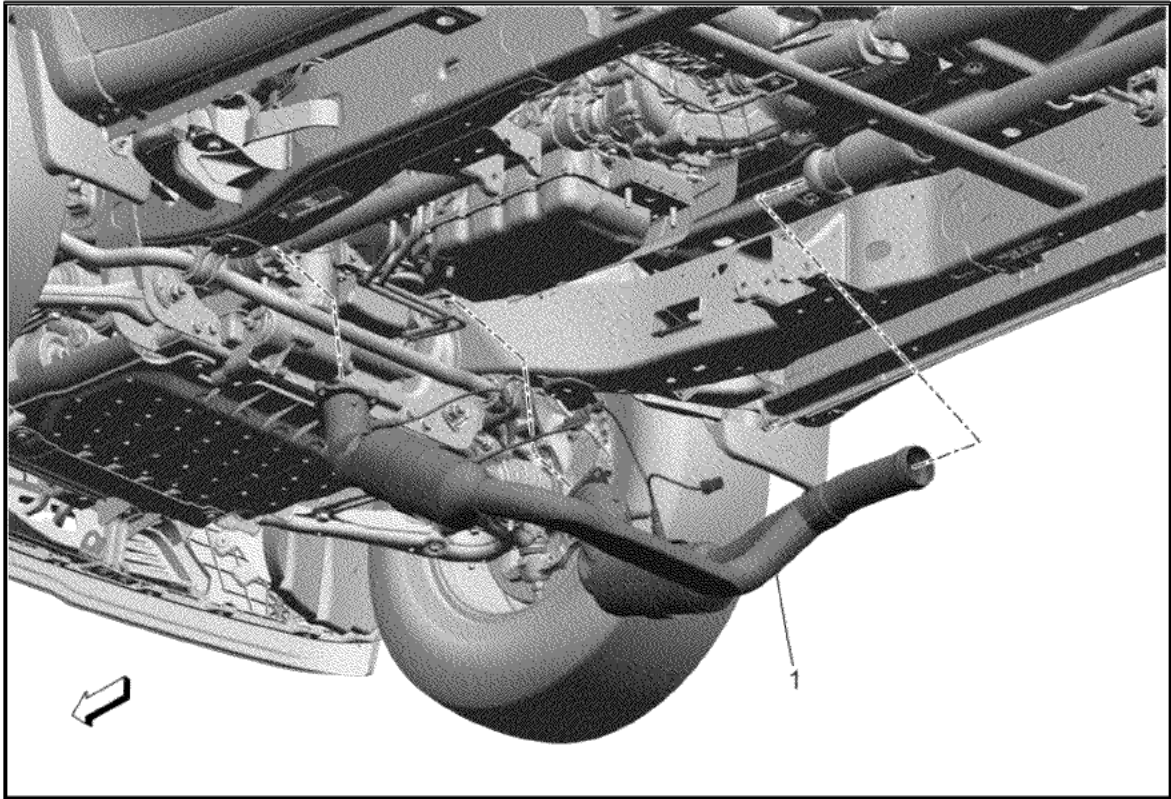

33. Three-Way Catalytic Converter (1) » Install

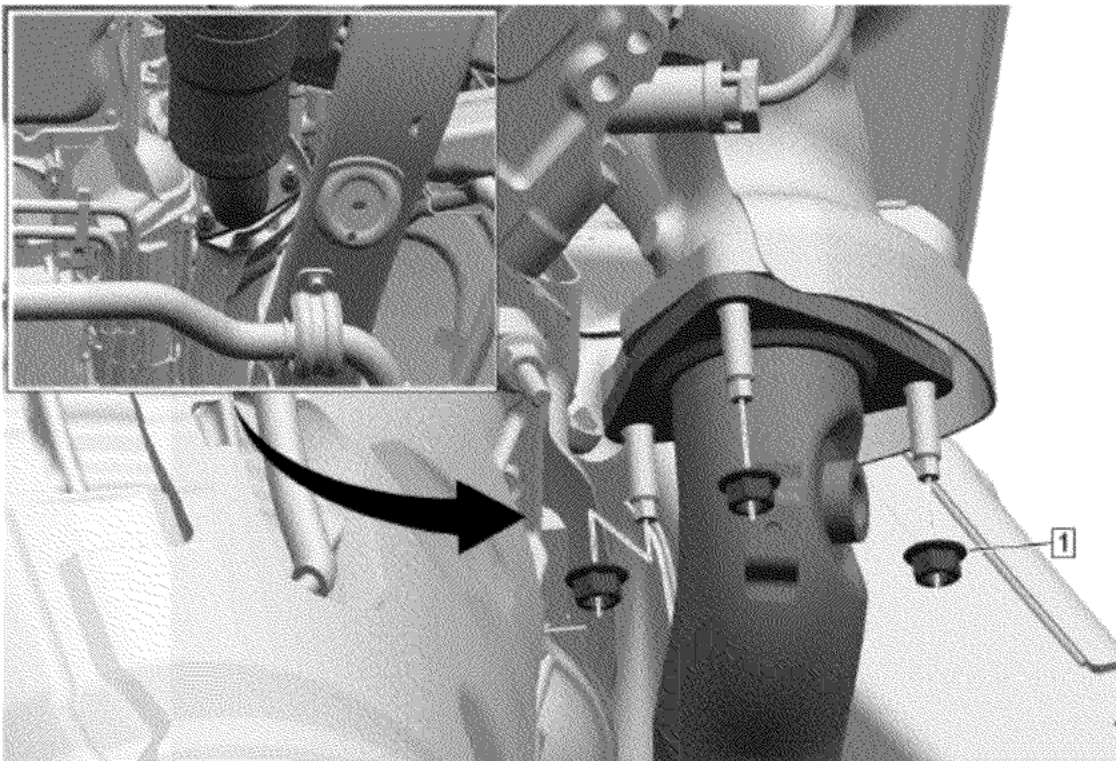

34. Exhaust Front Pipe Nut - Right Side (1) » Install and hand tighten [3x]
35. Exhaust Front Pipe Nut - Right Side (1) » Tighten [3x] — [Fastener Specifications](#)

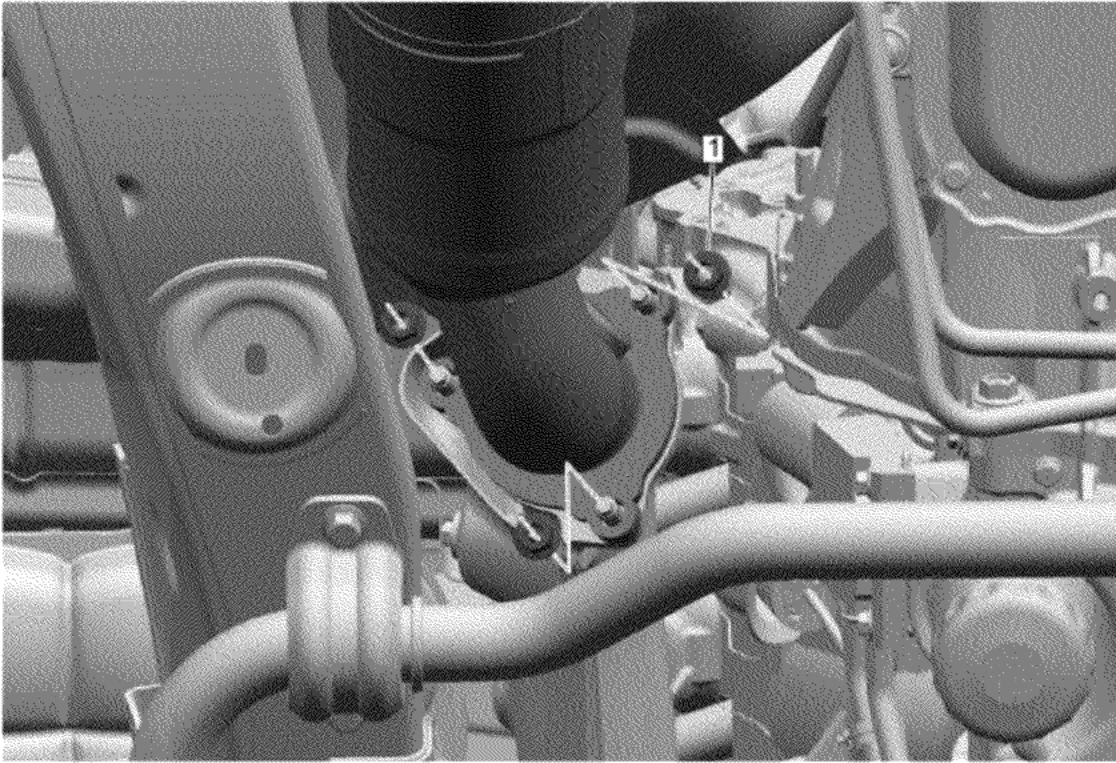

36. Exhaust Front Pipe Nut - Left Side (1) » Install and hand tighten [3x]
37. Exhaust Front Pipe Nut - Left Side (1) » Tighten [3x] — [Fastener Specifications](#)

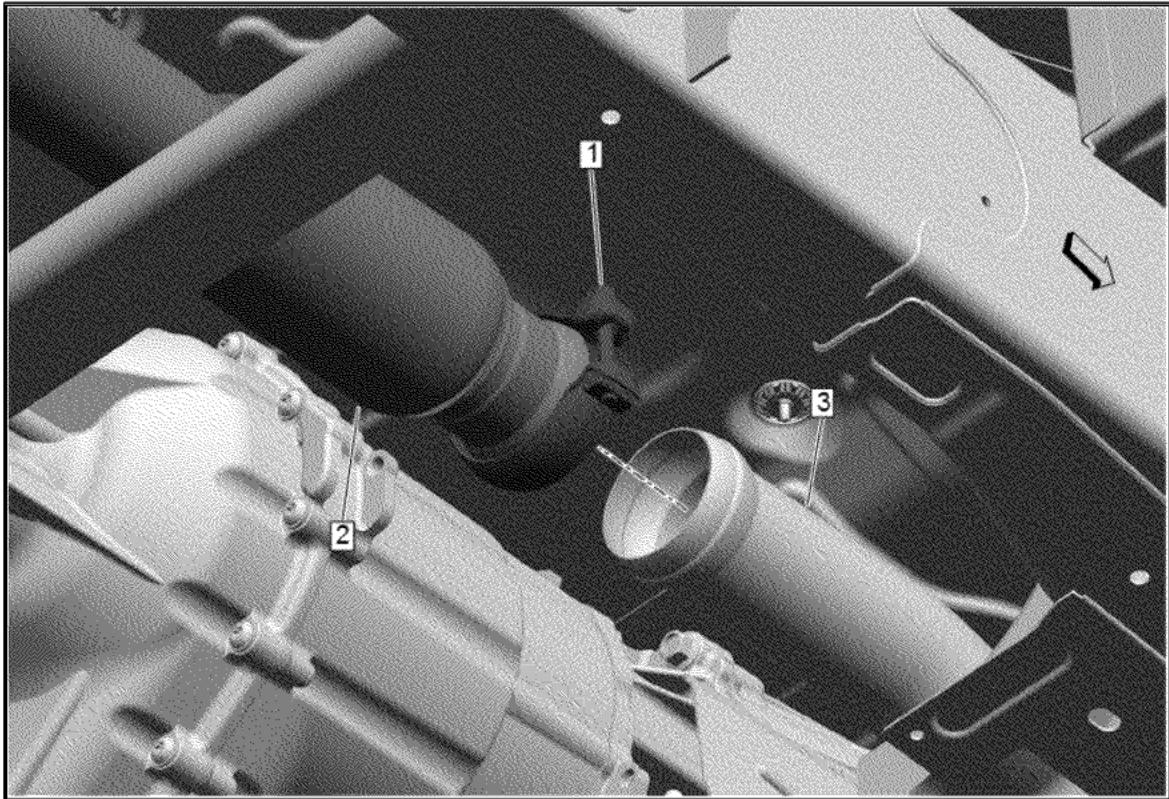

- 38. Exhaust Muffler (2) @ Three-Way Catalytic Converter (3) » Connect
- 39. Exhaust Pipe Clamp (1) » Tighten — [Fastener Specifications](#)

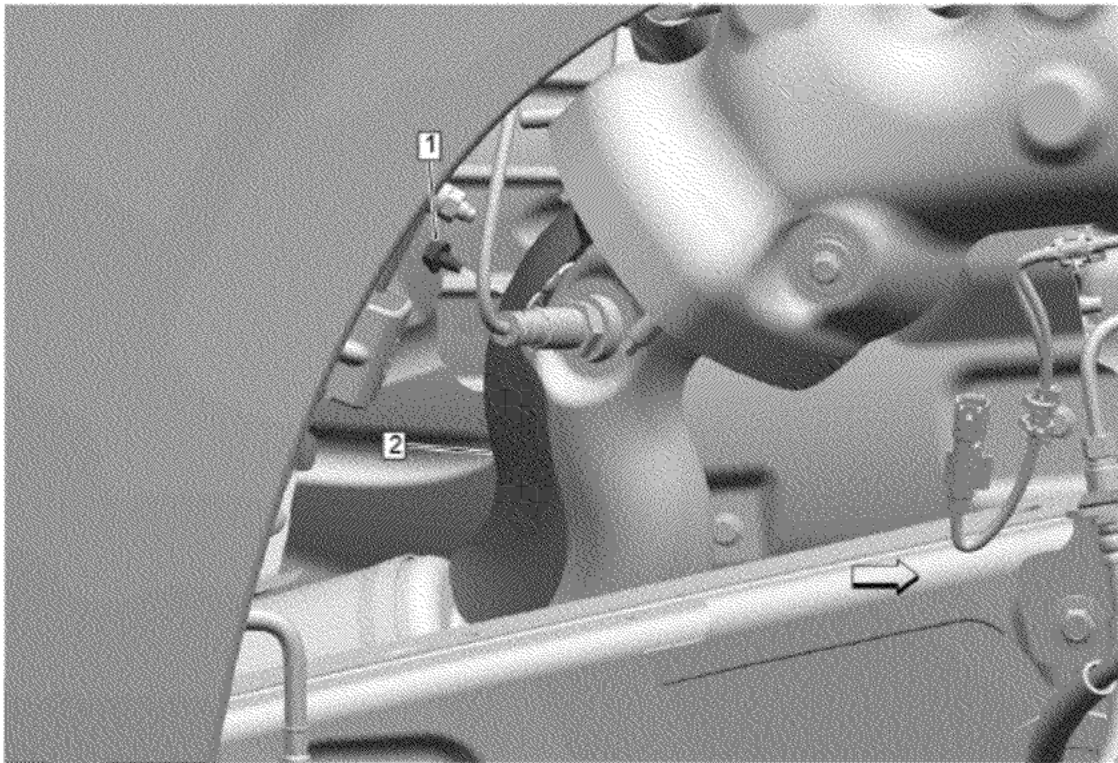

40. Exhaust Front Pipe Heat Shield - Right Side (2) » Install
41. Exhaust Heat Shield Bolt - Right Side (1) » Install and tighten — [Fastener Specifications](#)

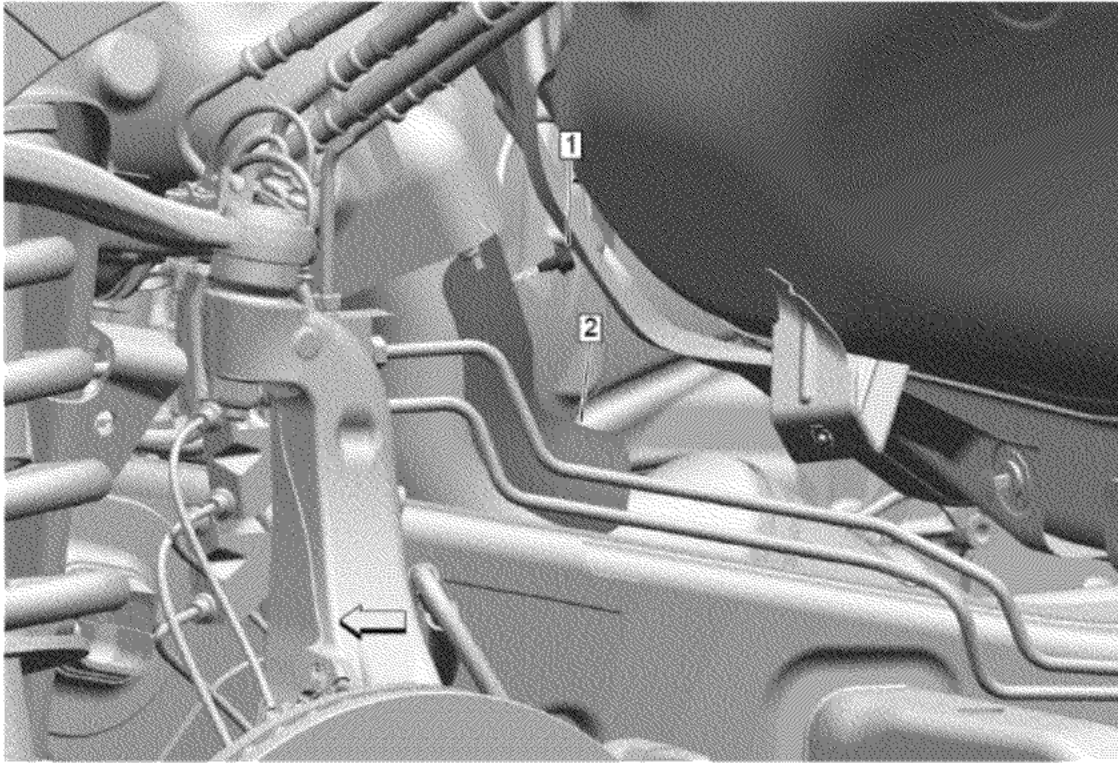

© 2025 General Motors. All rights reserved.

42. Exhaust Front Pipe Heat Shield - Left Side (2) » Install
43. Exhaust Heat Shield Bolt - Left Side (1) » Install and tighten — [Fastener Specifications](#)

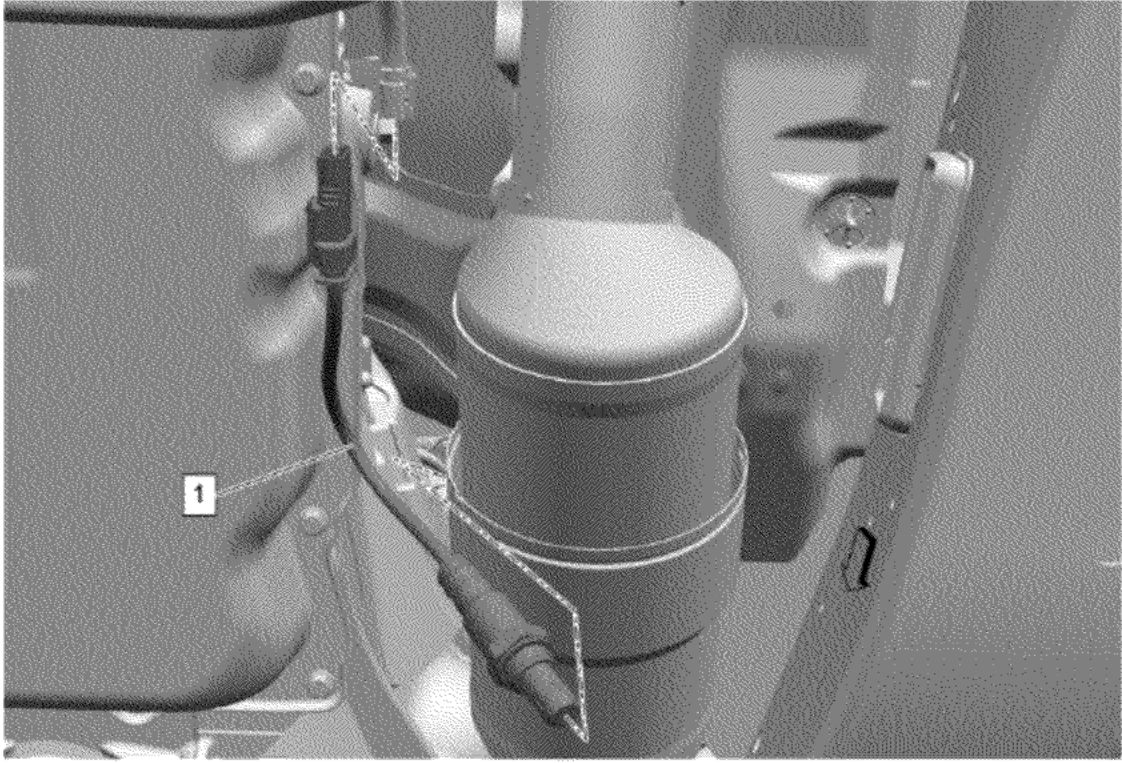

44. Electrical Connector @ Heated Oxygen Sensor - Bank 2 Sensor 2 » Connect

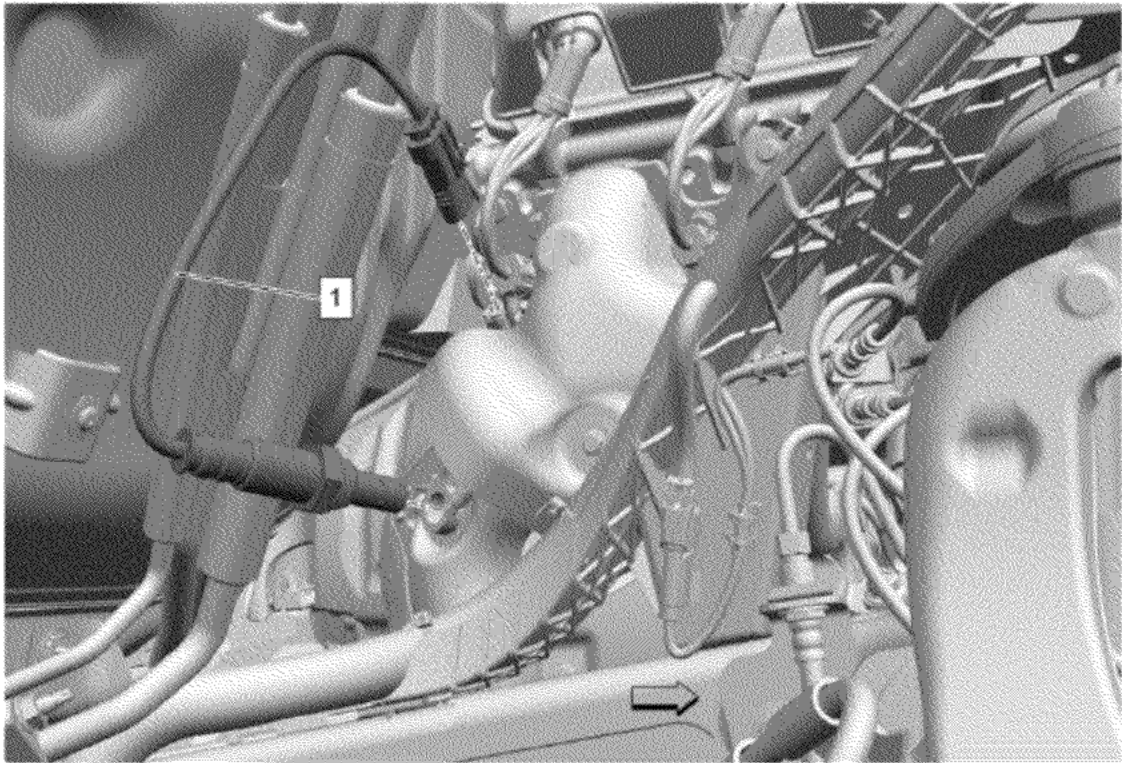

Note: A special anti-seize compound is used in the HO2S threads. The compound consists of liquid graphite and glass beads. The graphite tends to burn away, but the glass beads remain, making the sensor easier to remove. New, or service replacement sensors already have the compound applied to the threads. If the sensor is removed from an exhaust component and if for any reason the sensor is to be reinstalled, the threads must have anti-seize compound applied before reinstallation. [Adhesives, Fluids, Lubricants, and Sealers](#)

45. Using a suitable tool, install and tighten the heated oxygen sensor (1). [Fastener Specifications](#)
46. Electrical Connector @ Heated Oxygen Sensor - Bank 2 Sensor 1 » Connect

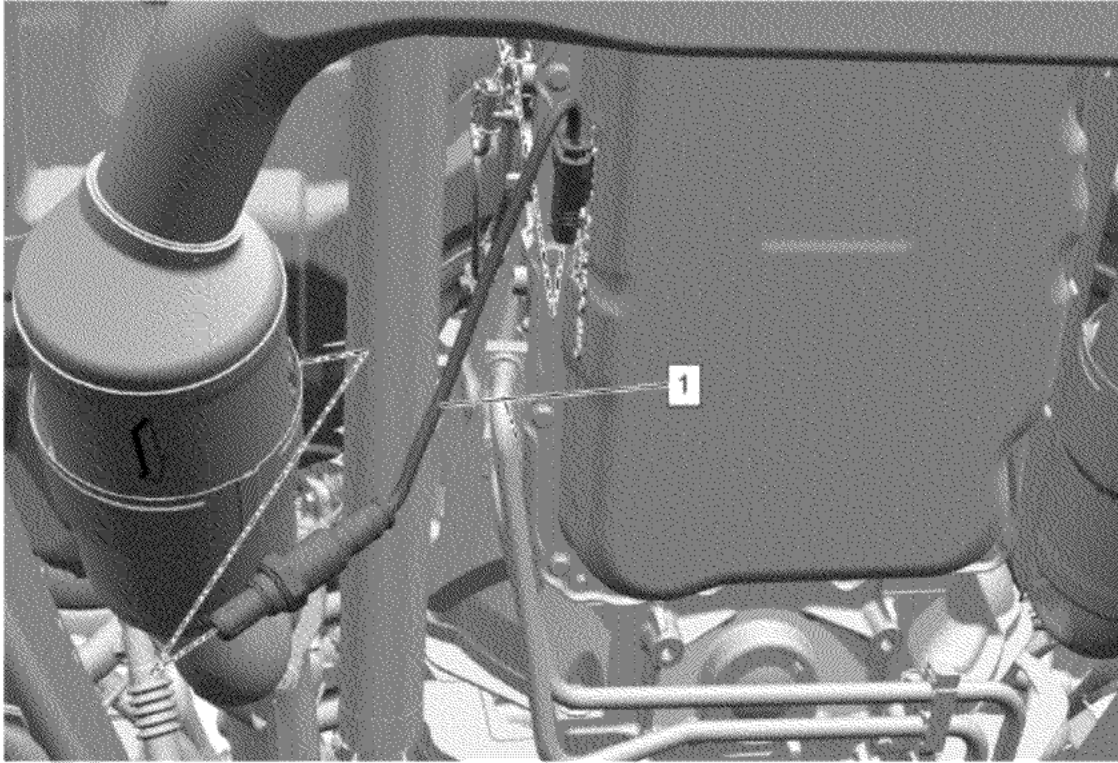

47. Electrical Connector @ Heated Oxygen Sensor - Bank 1 Sensor 2 » Connect

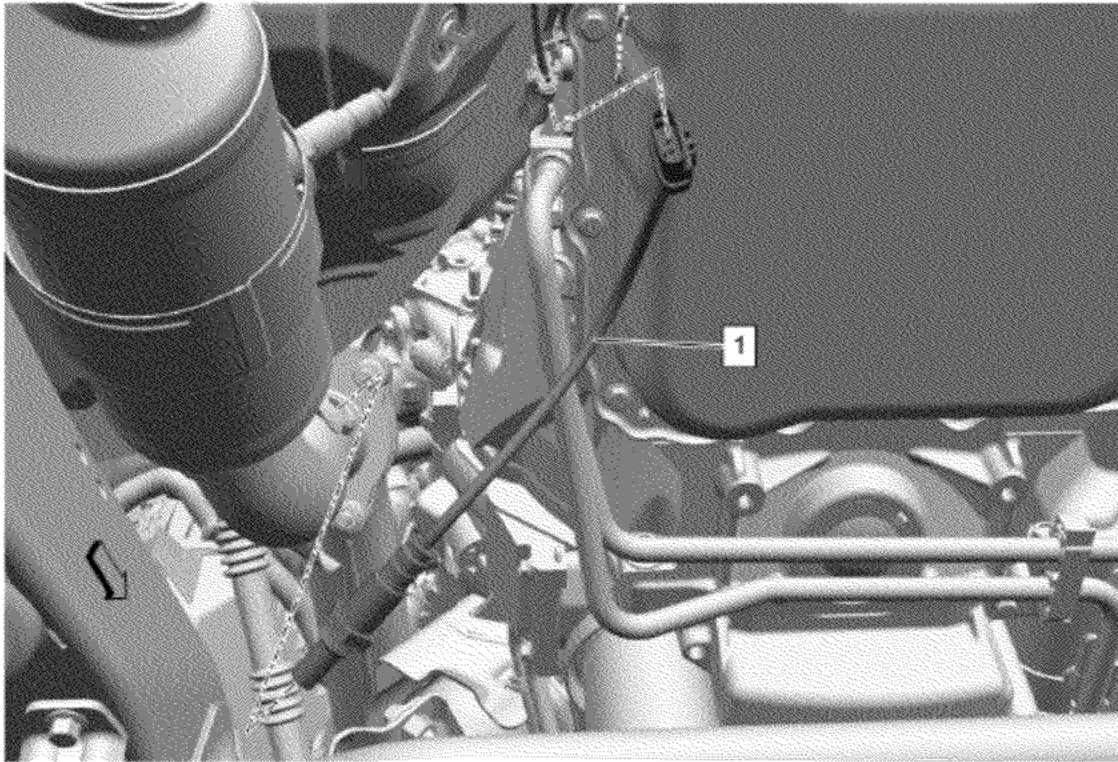

Note: A special anti-seize compound is used in the HO2S threads. The compound consists of liquid graphite and glass beads. The graphite tends to burn away, but the glass beads remain, making the sensor easier to remove. New, or service replacement sensors already have the compound applied to the threads. If the sensor is removed from an exhaust component and if for any reason the sensor is to be reinstalled, the threads must have anti-seize compound applied before reinstallation. [Adhesives, Fluids, Lubricants, and Sealers](#)

48. Using a suitable tool, install and tighten the heated oxygen sensor (1). [Fastener Specifications](#)
49. Electrical Connector @ Heated Oxygen Sensor Bank 1 Sensor 1 - Bank 1 Sensor 1 Connect

© 2025 General Motors. All rights reserved.

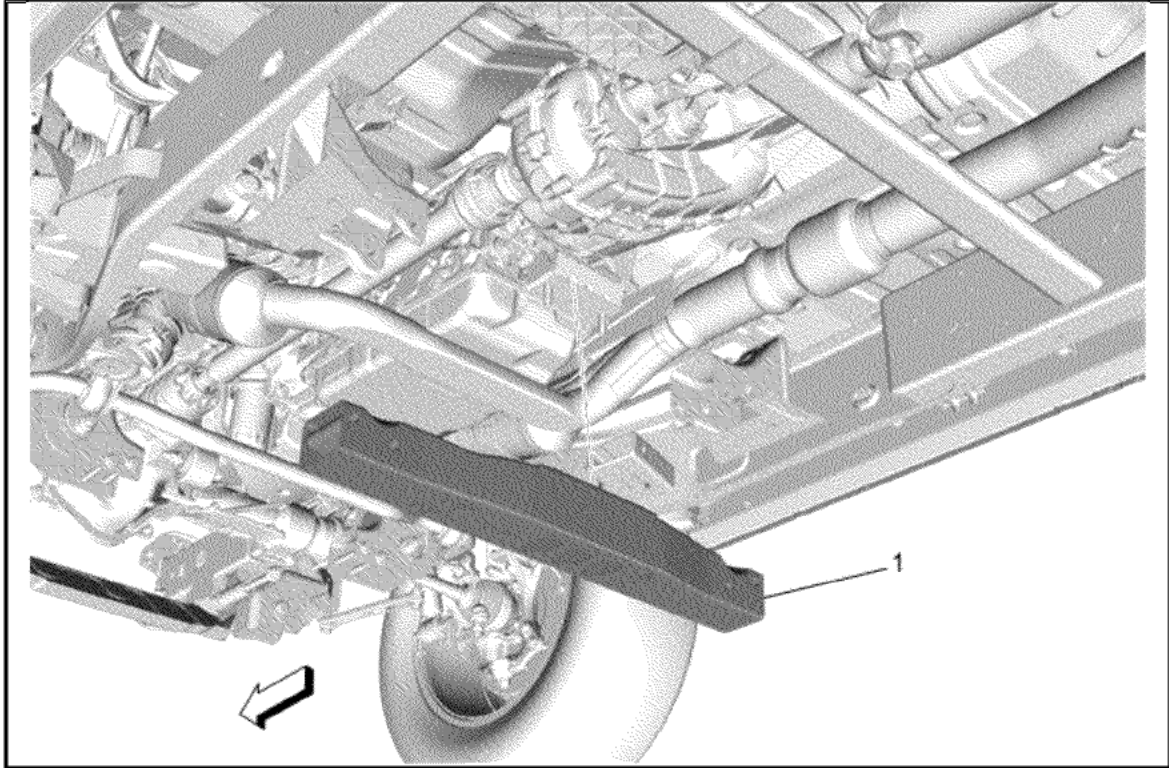

50. Transmission Support Crossmember (1) » Install

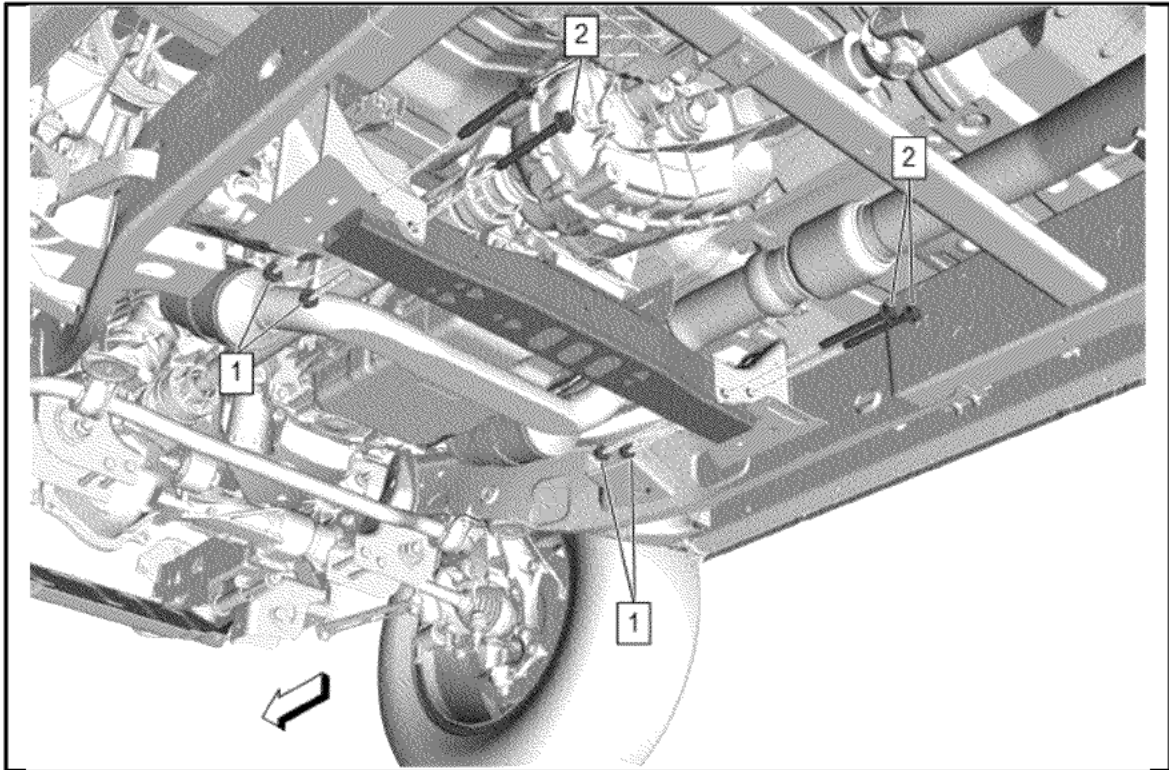

51. Transmission Support Crossmember Bolt (2) » Install [4x]

52. Transmission Support Crossmember Nut (1) » Install and tighten [4x] — [Fastener Specifications](#)

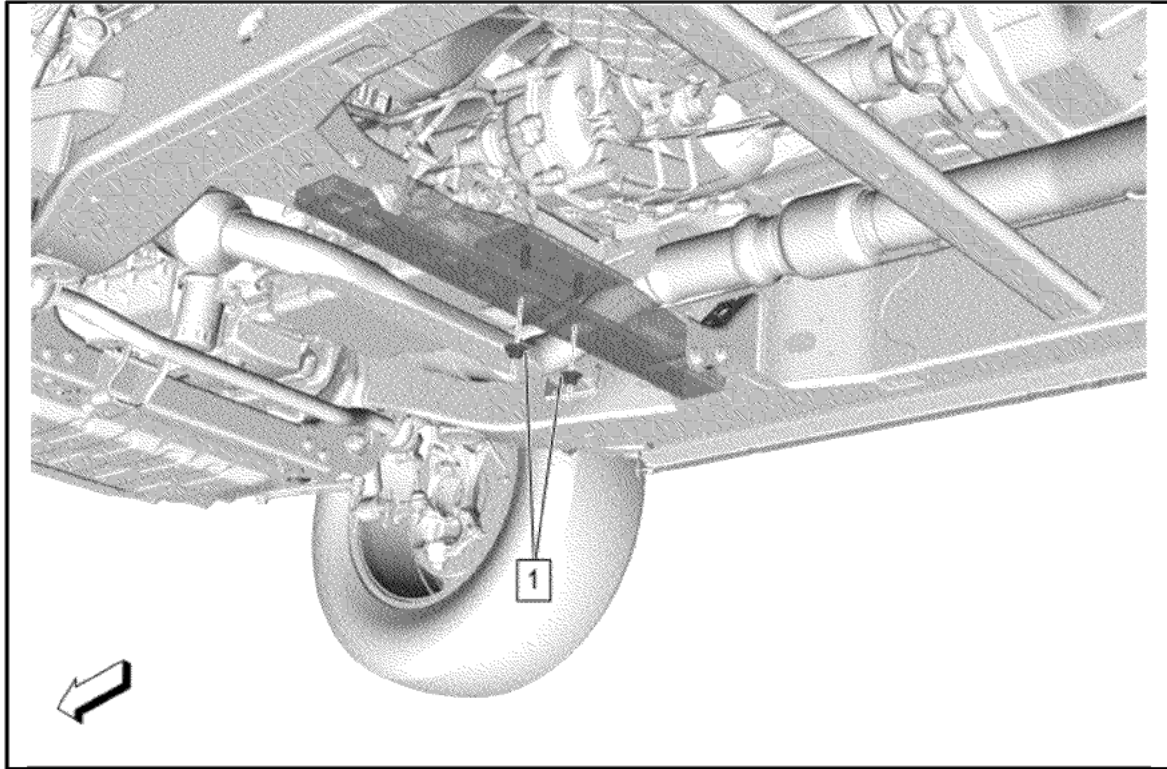

© 2025 General Motors. All rights reserved.

53. Transmission Mount Nut (1) » Install and tighten [2x] — [Fastener Specifications](#)
54. Remove the transmission jack.

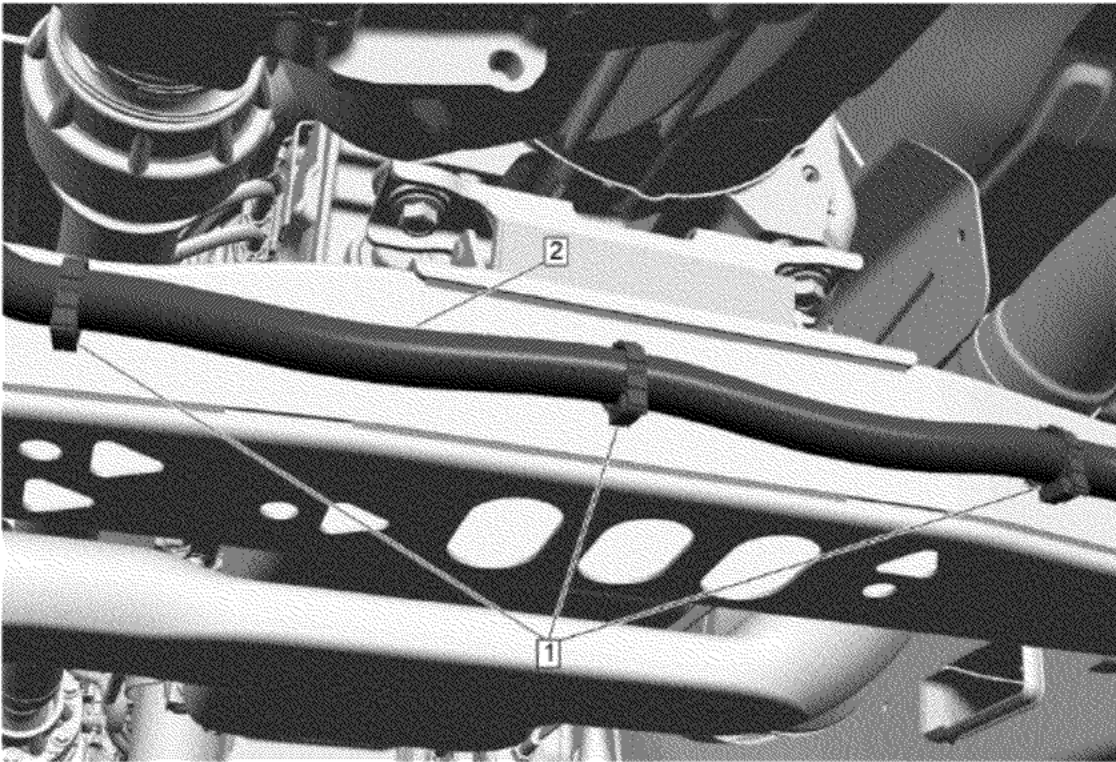

55. { If equipped } Install the wiring harness (2) as necessary and install the harness retainers (1) into the transmission support crossmember.

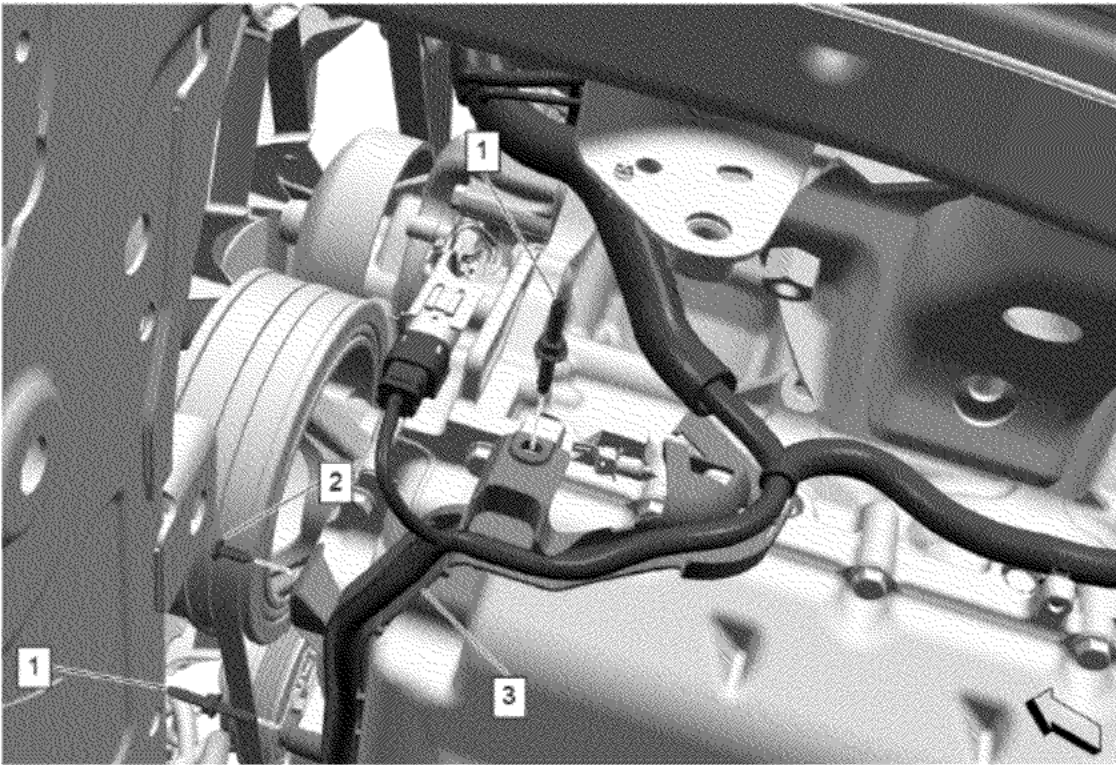

56. Engine Wiring Harness (3) » Install

57. Engine Wiring Harness Retainer (2) » Install

58. Engine Wiring Harness Ground Stud (1) » Install and tighten [2x] — [Fastener Specifications](#)

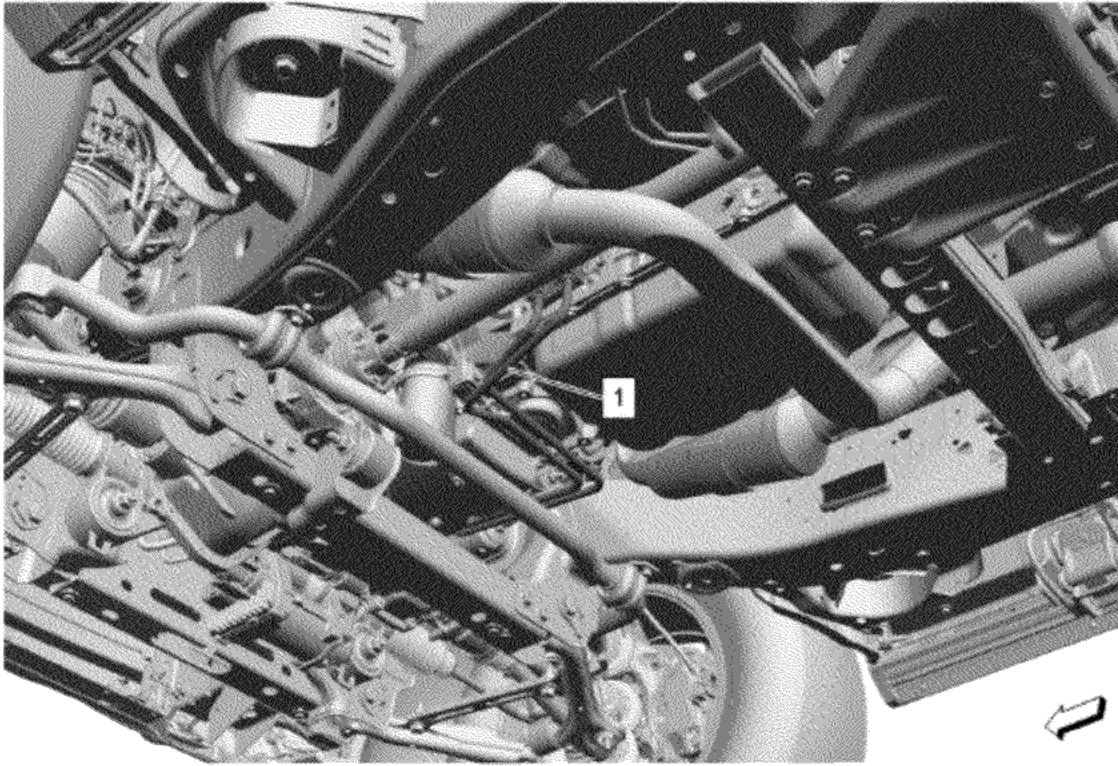

© 2025 General Motors. All rights reserved.

59. Reposition the transmission cooler inlet and outlet pipe (1) as necessary.

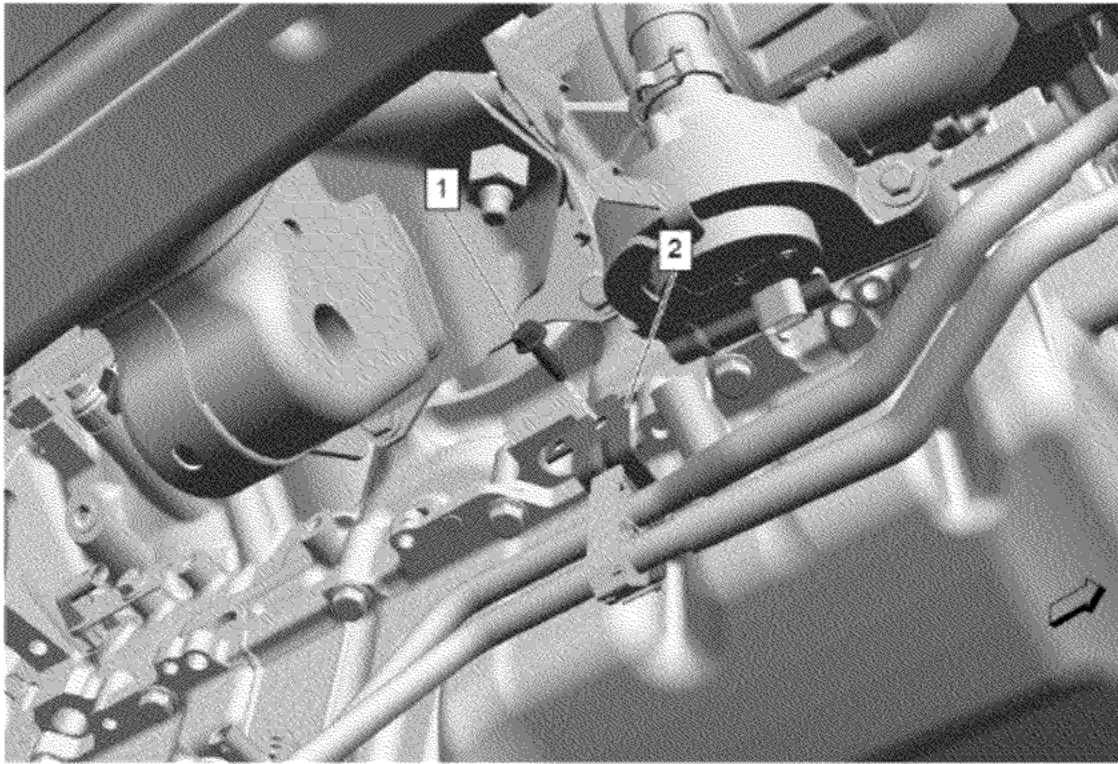

Note: Components removed in graphic to better illustrate service parts.

60. Transmission Fluid Cooler Pipe Clip Bracket (2) @ Oil Pan » Install

61. Transmission Fluid Cooler Pipe Clip Bolt (1) @ Oil Pan » Install and tighten — Fastener Specifications

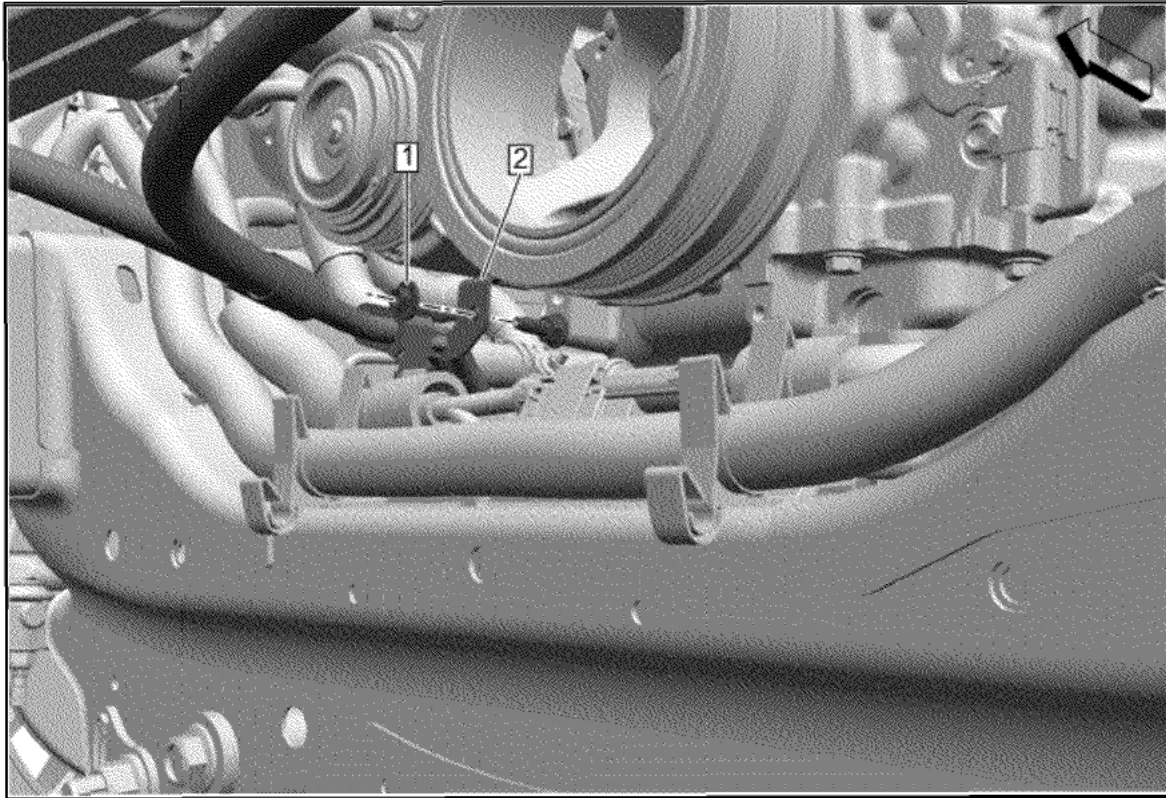

© 2025 General Motors. All rights reserved.

62. Position the transmission fluid cooler inlet and outlet pipe bracket (2).
63. Install and tighten the transmission fluid auxiliary cooler pipe bracket nut (1). [Fastener Specifications](#)

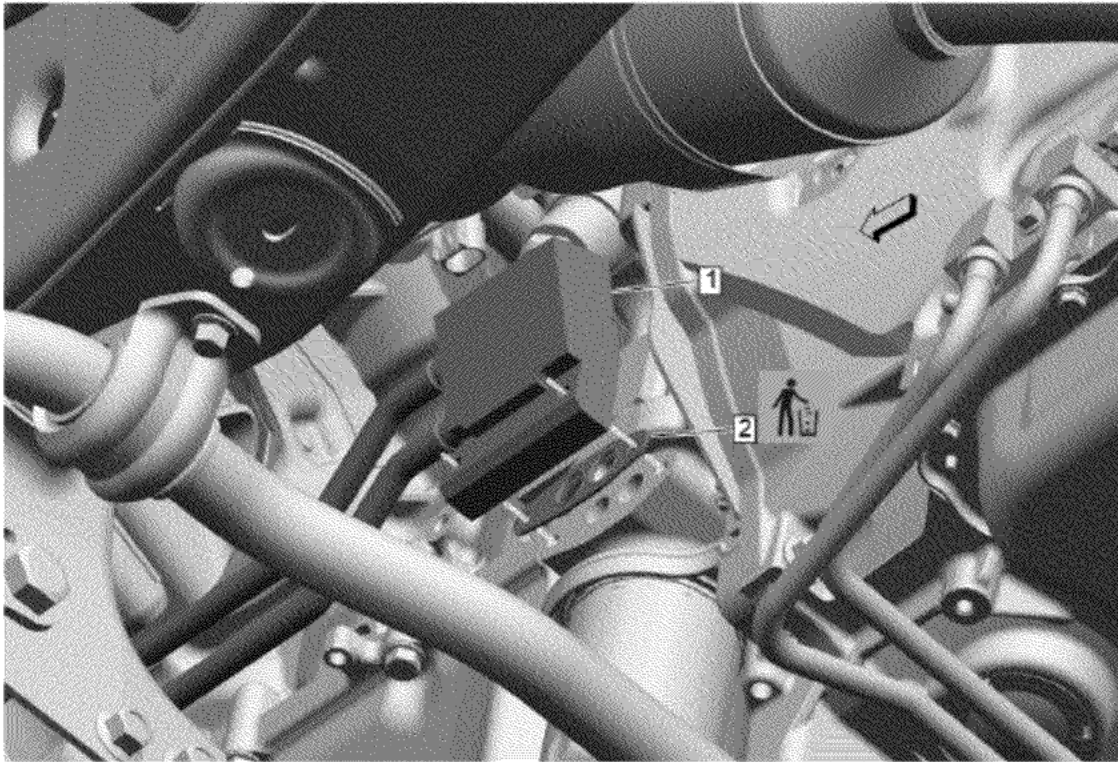

- 64. Engine Oil Cooler Gasket (2) » Install NEW
- 65. Engine Oil Cooler Hose (1) @ Oil Pan » Install

© 2025 General Motors. All rights reserved.

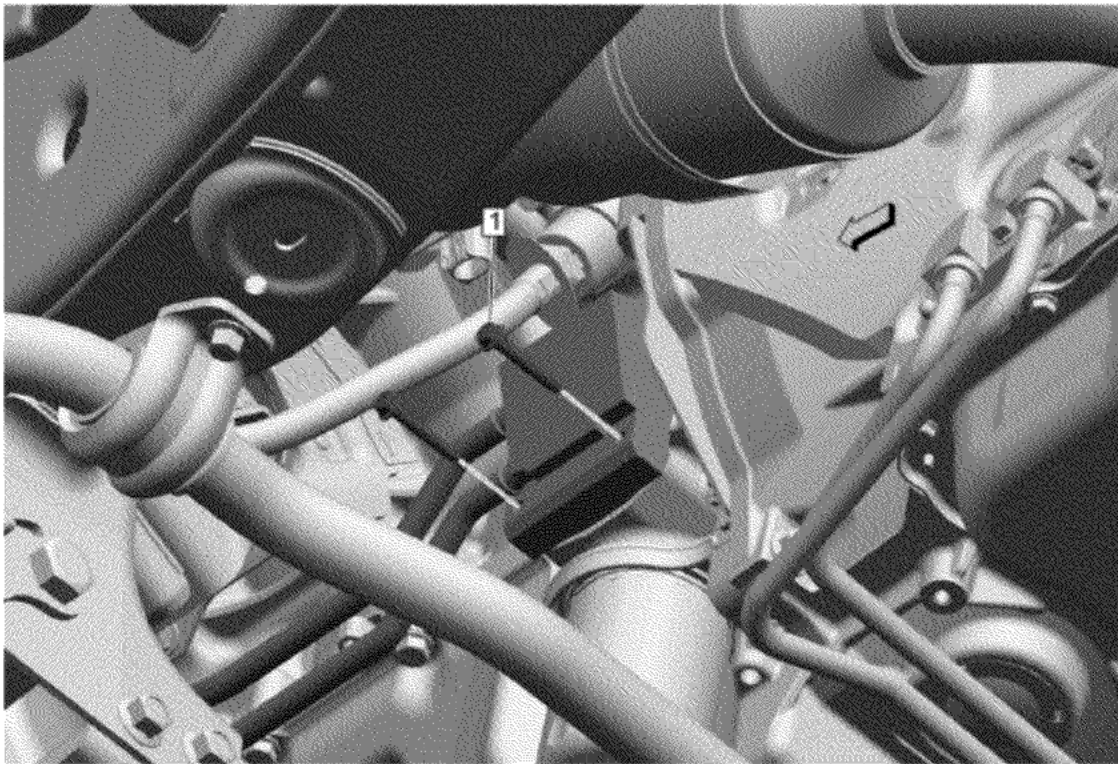

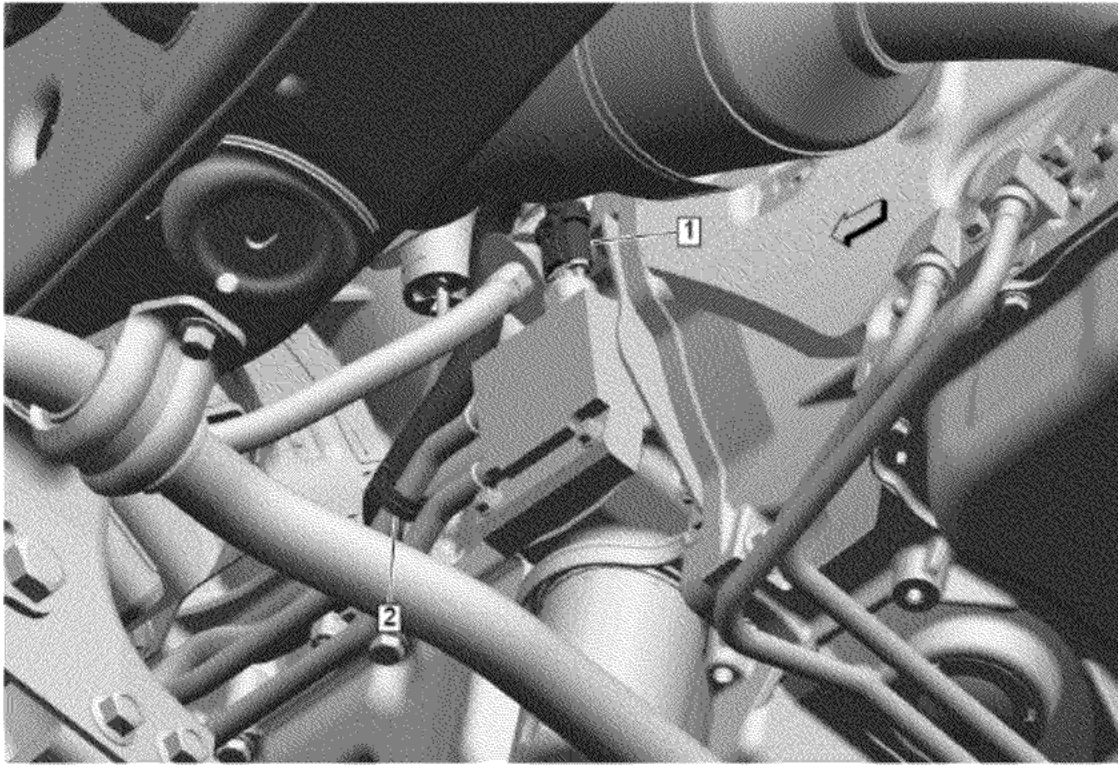
66. Engine Oil Cooler Coolant Hose Bolt (1) » Install and tighten [2x] — [Fastener Specifications](#)

67. Electrical Connector (1) @ Engine Oil Pressure Sensor » Connect

68. Wiring Harness Retainer (2) @ Engine Oil Cooler Hose » Install

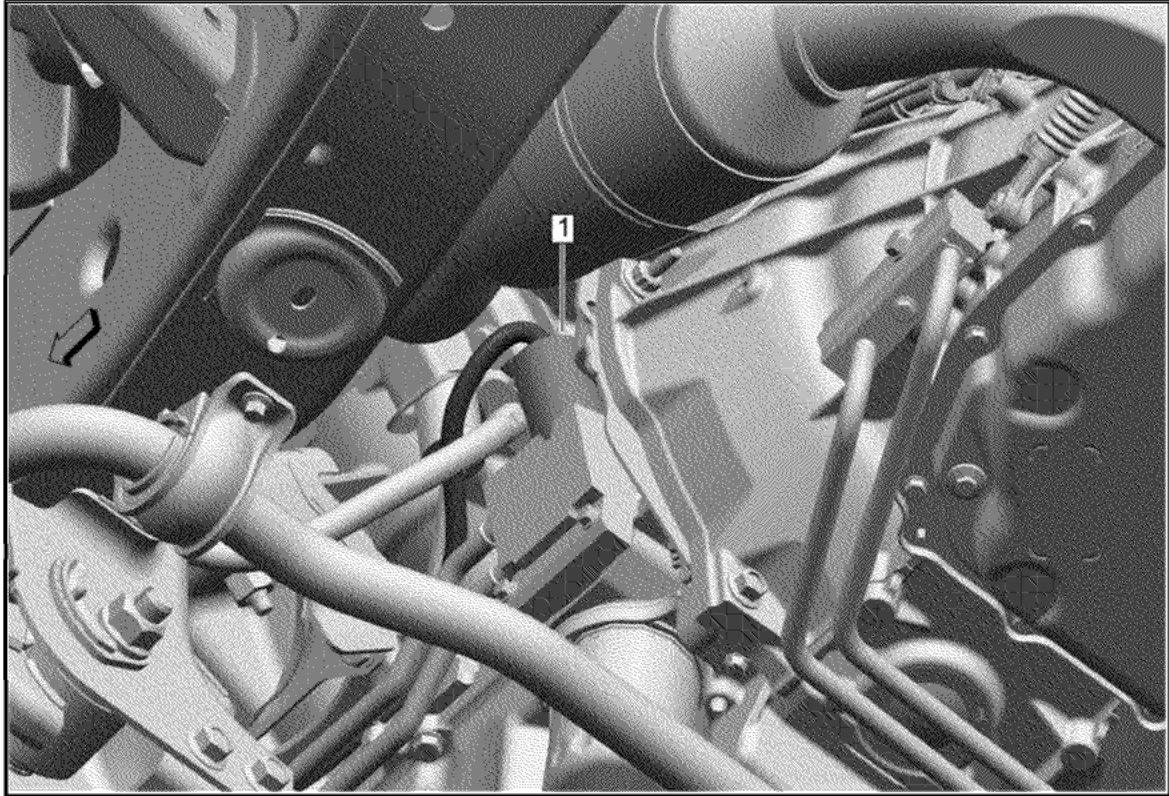

69. Engine Oil Pressure Sensor Sleeve (1) » Install

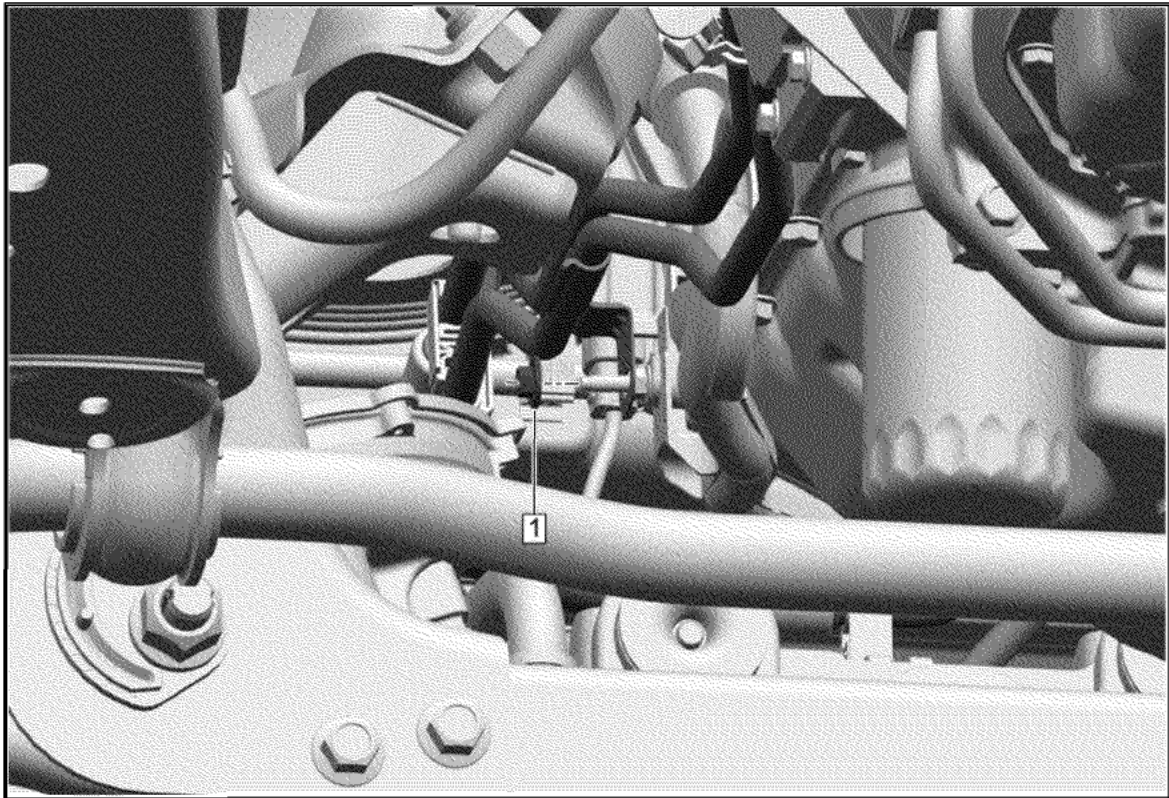

70. Engine Oil Cooler Hose Bracket Nut (1) » Install and tighten — [Fastener Specifications](#)

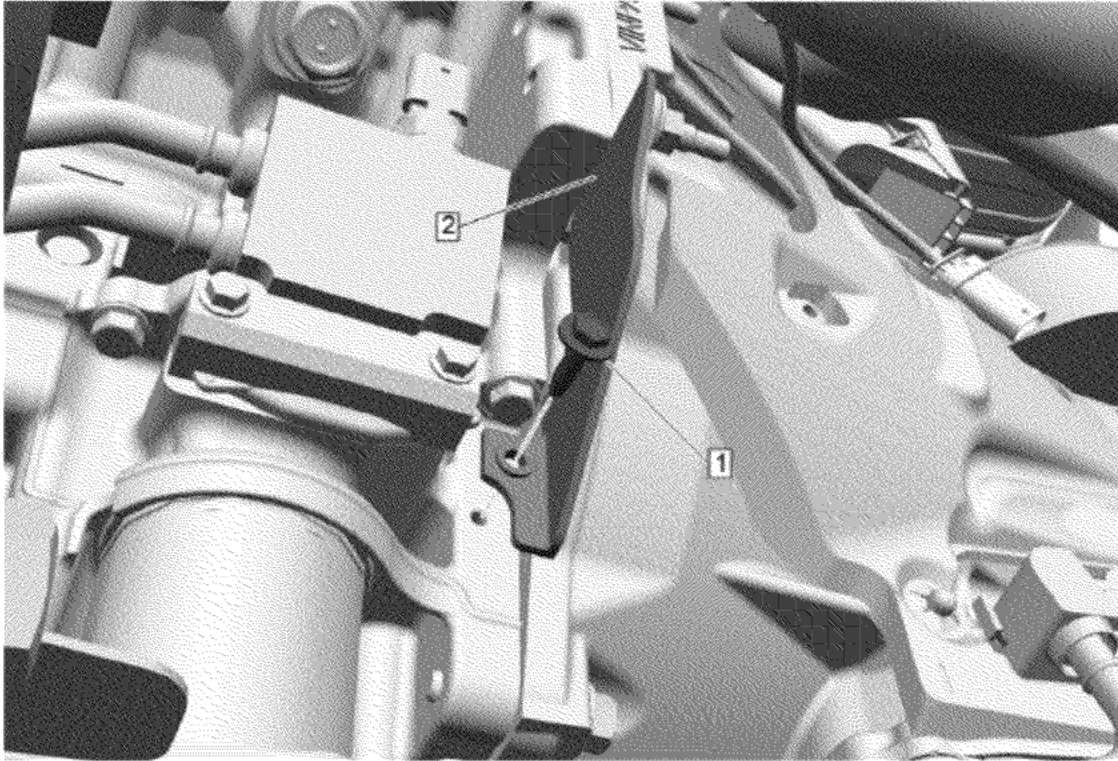

71. Transmission Converter Cover - Left Side (2) » Install

72. Torque Converter Cover Bolt - Left Side (1) » Install and tighten — [Fastener Specifications](#)

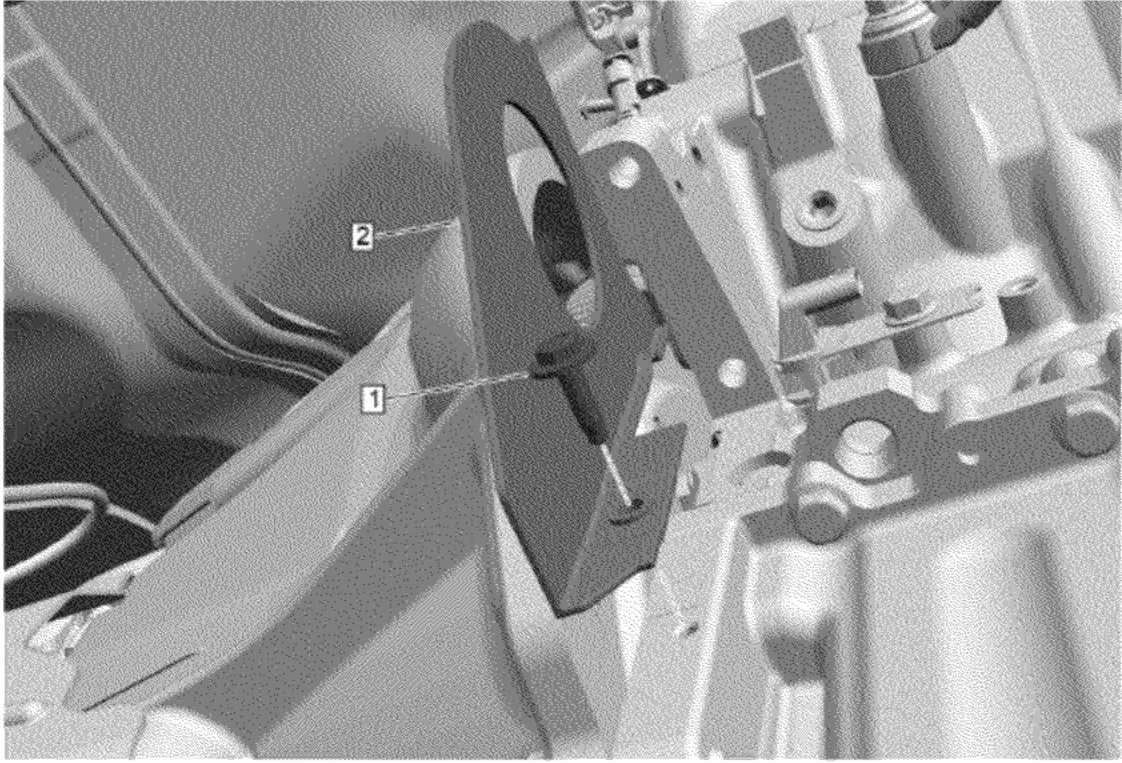

73. Transmission Converter Cover - Right Side (2) » Install

74. Torque Converter Cover Bolt - Right Side (1) » Install and tighten — [Fastener Specifications](#)

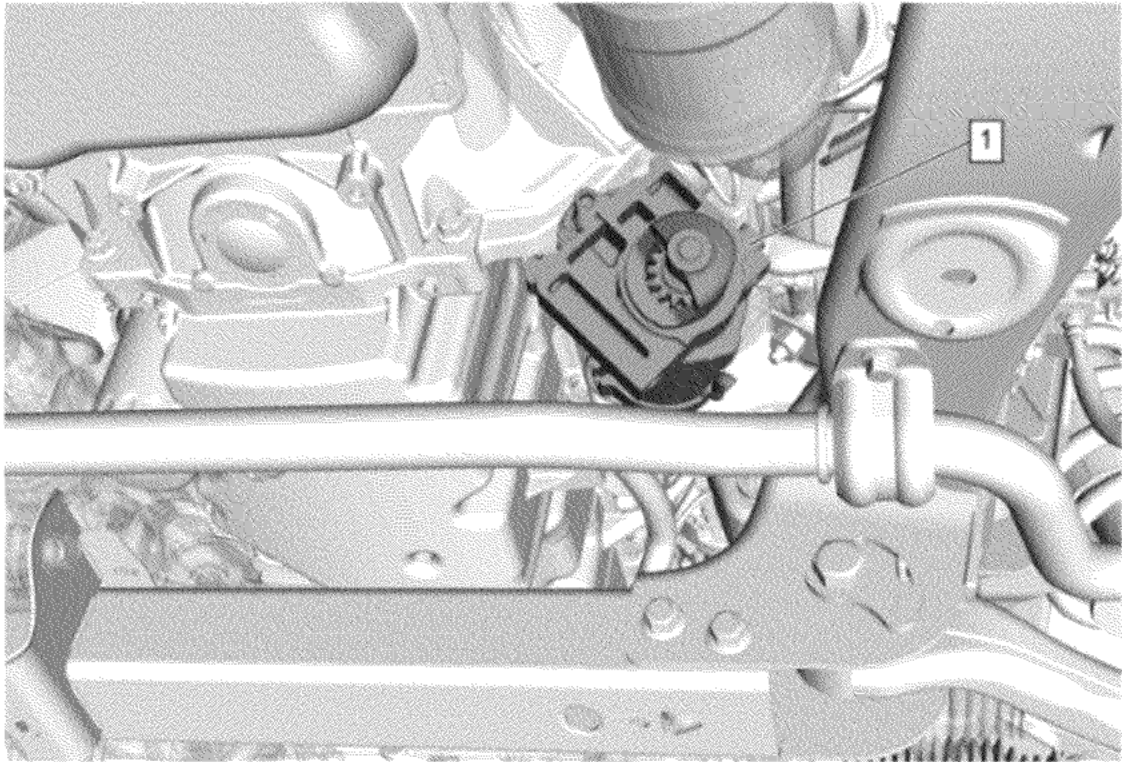

75. Starter (1) » Install

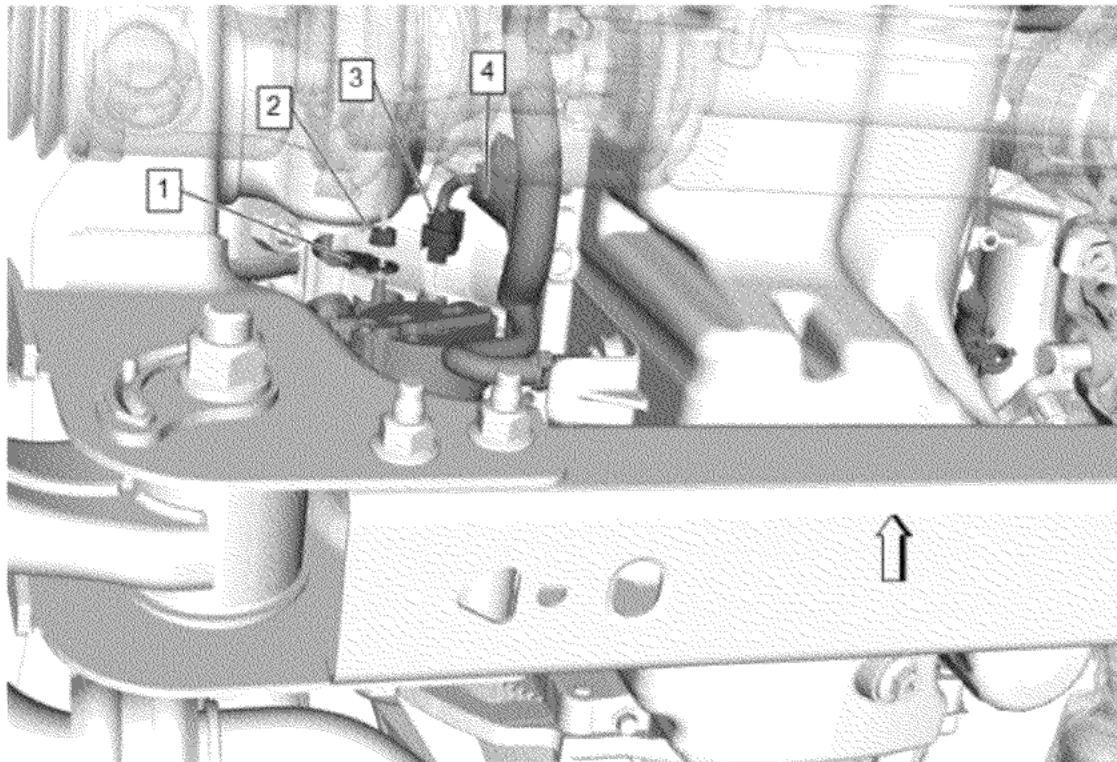

© 2025 General Motors. All rights reserved.

76. Electrical Connector (3) » Connect

77. Protective Sleeve (4) » Install

78. Starter Solenoid Cable (1) » Install

79. Starter Solenoid Cable Nut (2) » Install and tighten — [Fastener Specifications](#)

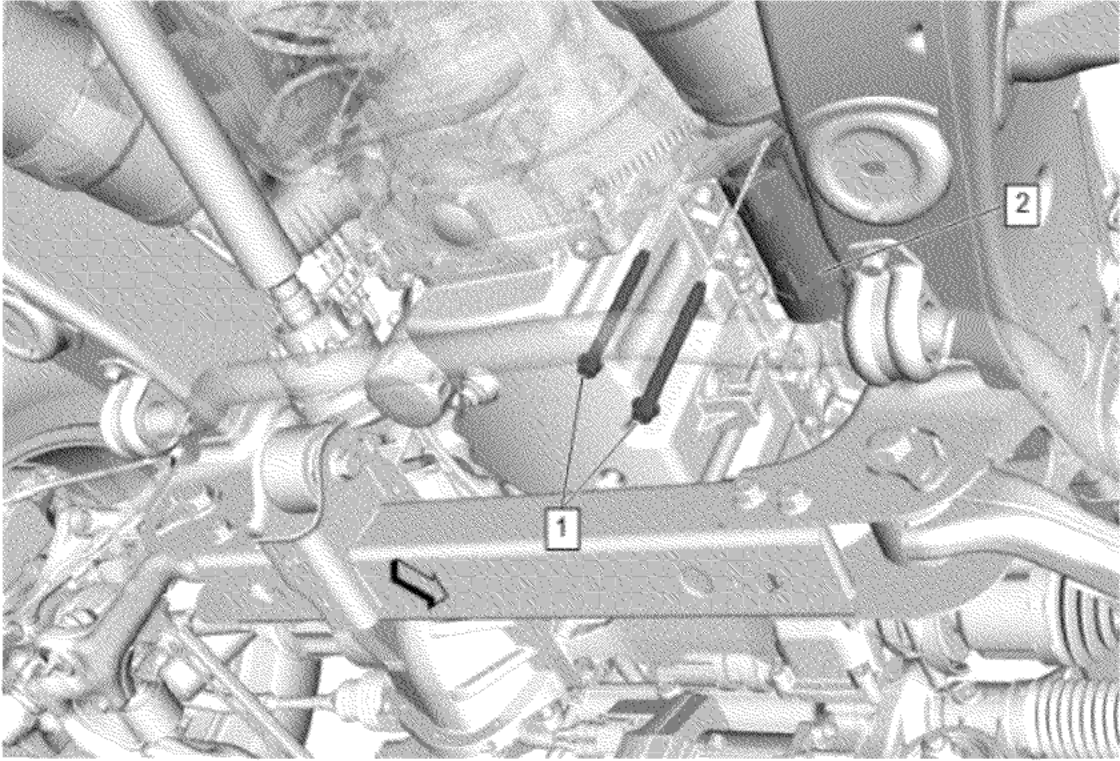

80. Starter Bolt (1) » Install and tighten [2x] — [Fastener Specifications](#)

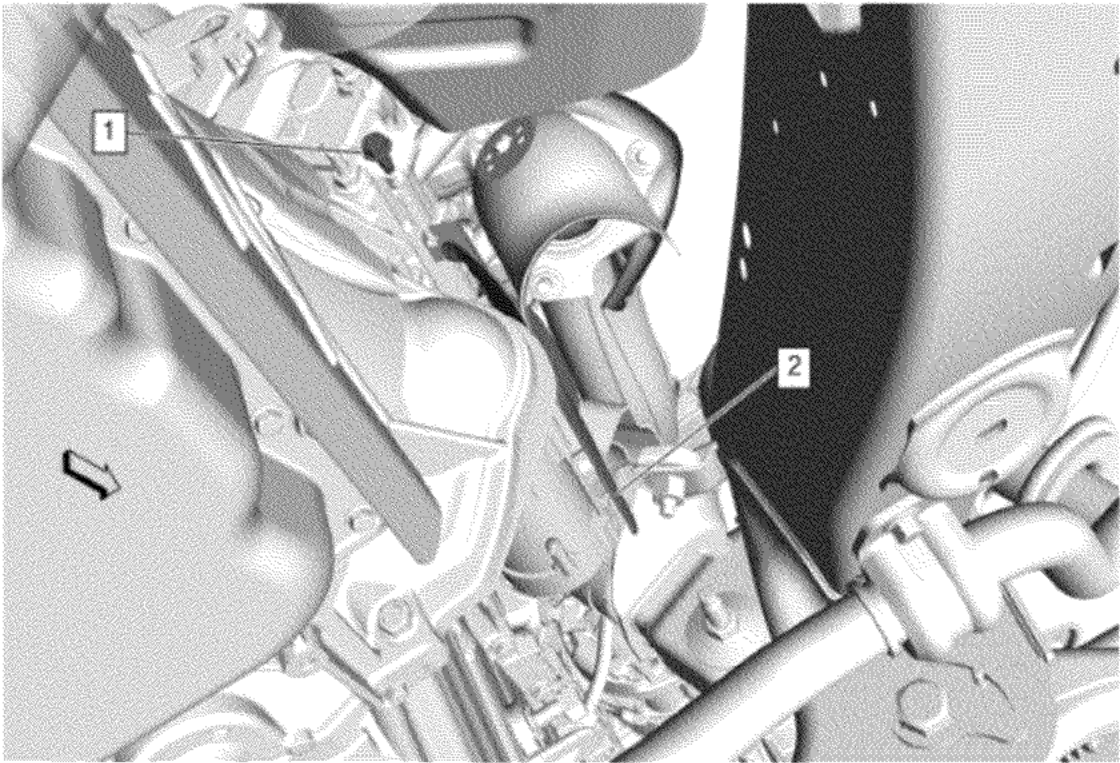

81. Starter Heat Shield (2) » Install

82. Starter Heat Shield Bolt (1) » Install and tighten — [Fastener Specifications](#)

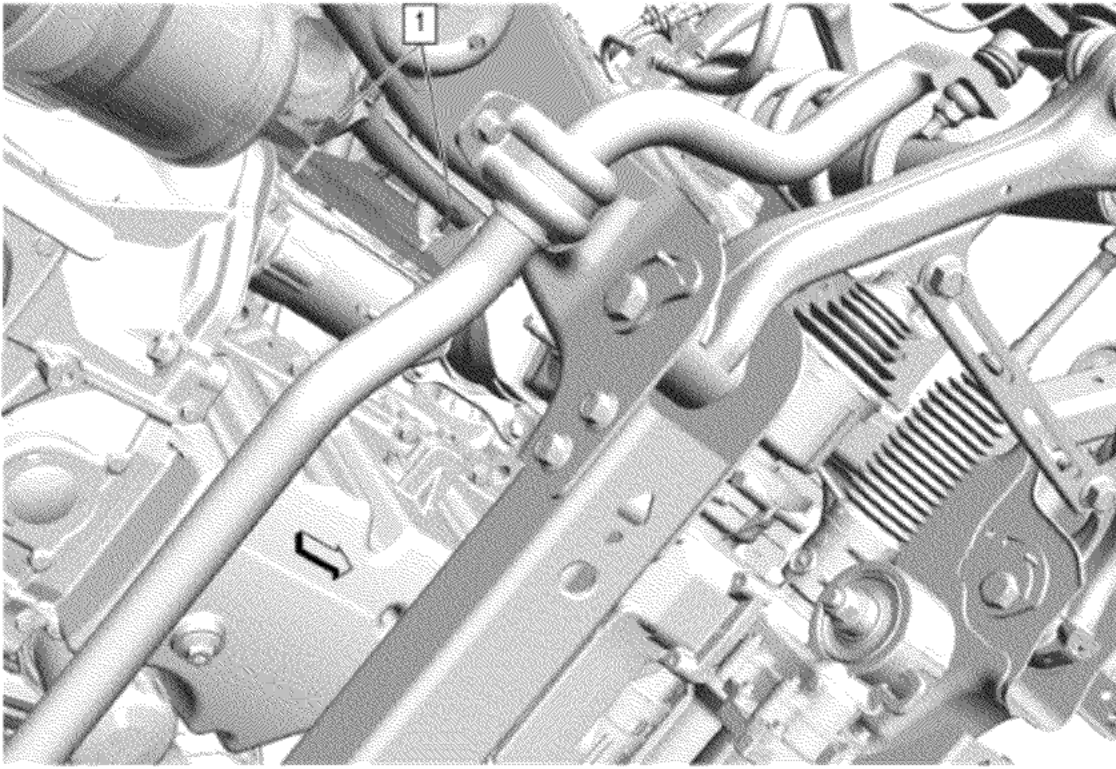

© 2025 General Motors. All rights reserved.

83. Starter Heat Shield Bolt (1) » Install and tighten [2x] — [Fastener Specifications](#)

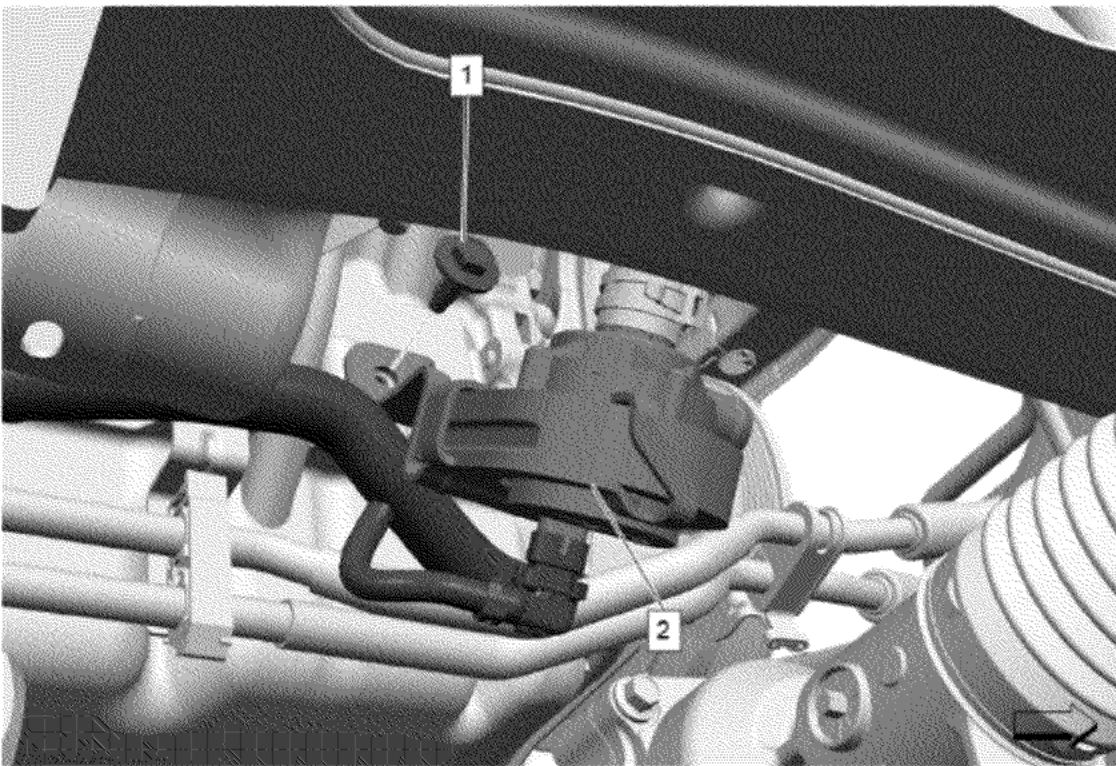

Note: Some components not shown for graphic clarity.

84. Install the heater coolant pump and heater water auxiliary pump bracket (2) as assembly.
85. Heater Water Auxiliary Pump Bolt (1) » Install and tighten — [Fastener Specifications](#)
86. Electrical Connector @ Heater Coolant Pump (2) » Connect

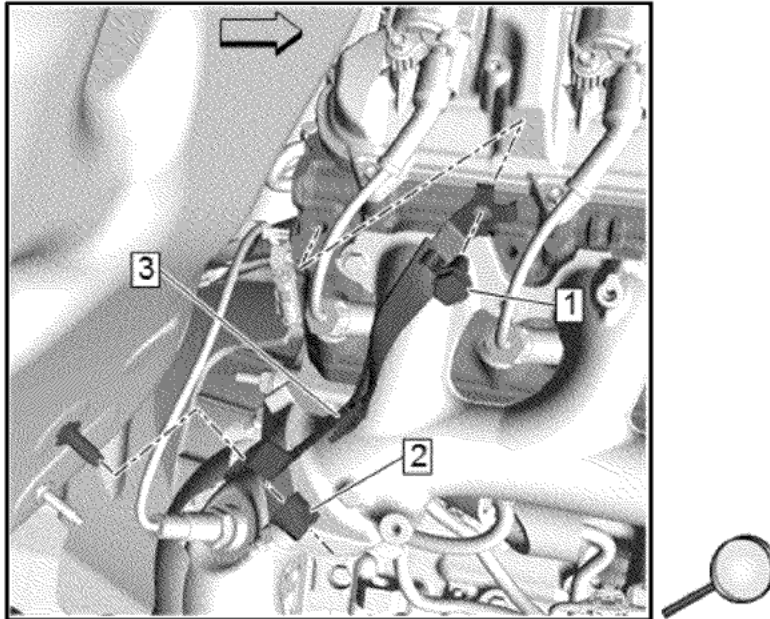

87. Battery Negative Cable Extension Cable Strap (3) @ Engine Block » Install
88. Engine Wiring Harness Ground Bolt (1) @ Engine Block » Install and tighten — [Fastener Specifications](#)

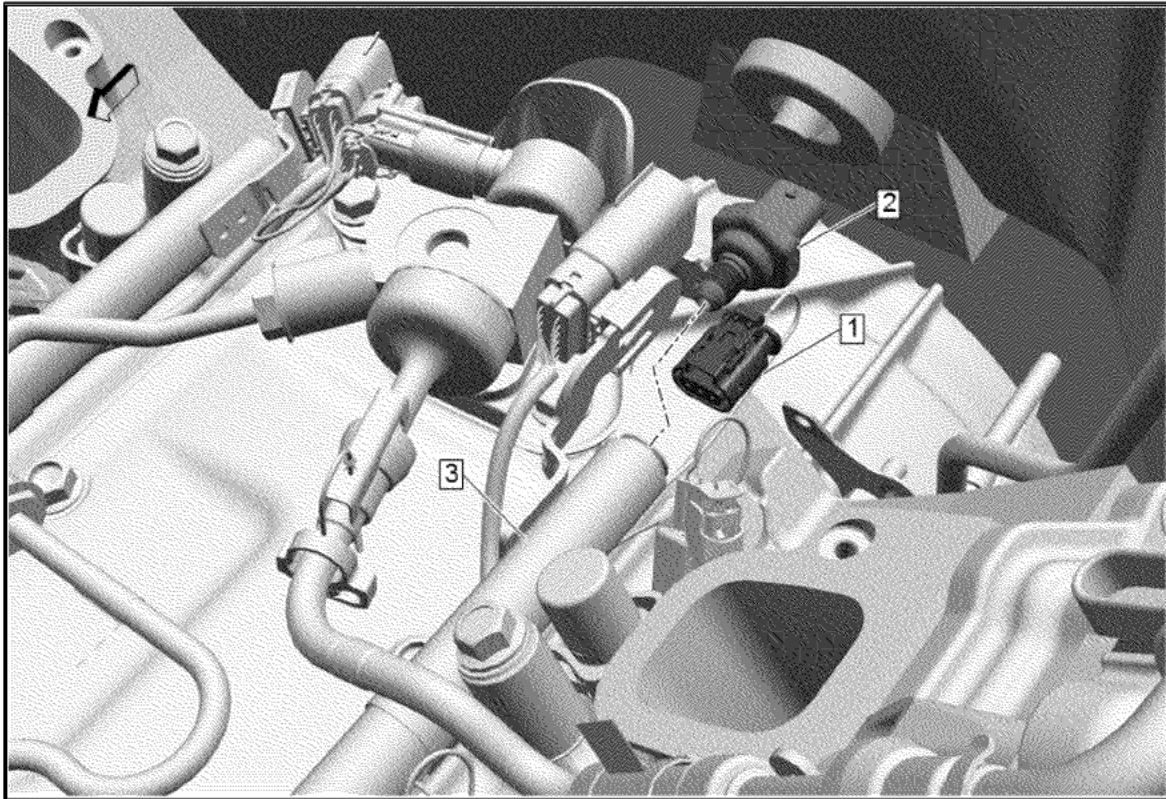

Caution: To tighten or loosen the fuel injection fuel rail fuel pressure sensor, apply force **ONLY** to the attached hexagon. Applying force to the plastic housing of the sensor may damage the sensor.

Note: Ensure the fuel rail threads are clean and free of any excess fuel, or the fuel rail pressure sensor will **NOT** seal properly.

89. Lubricate the threads and sealing surface of the fuel rail pressure sensor (2) with one drop of clean engine oil.
90. Install the fuel rail pressure sensor (2) and hand tighten.
91. Remove the fuel rail pressure sensor (2) from the fuel injection fuel rail (3) and re-lubricate with one drop of clean engine oil.
92. Fuel Rail Pressure Sensor (2) @ Fuel Injection Fuel Rail (3) » Install and tighten — [Fastener Specifications](#)
93. Electrical Connector (1) @ Fuel Rail Pressure Sensor (2) » Connect

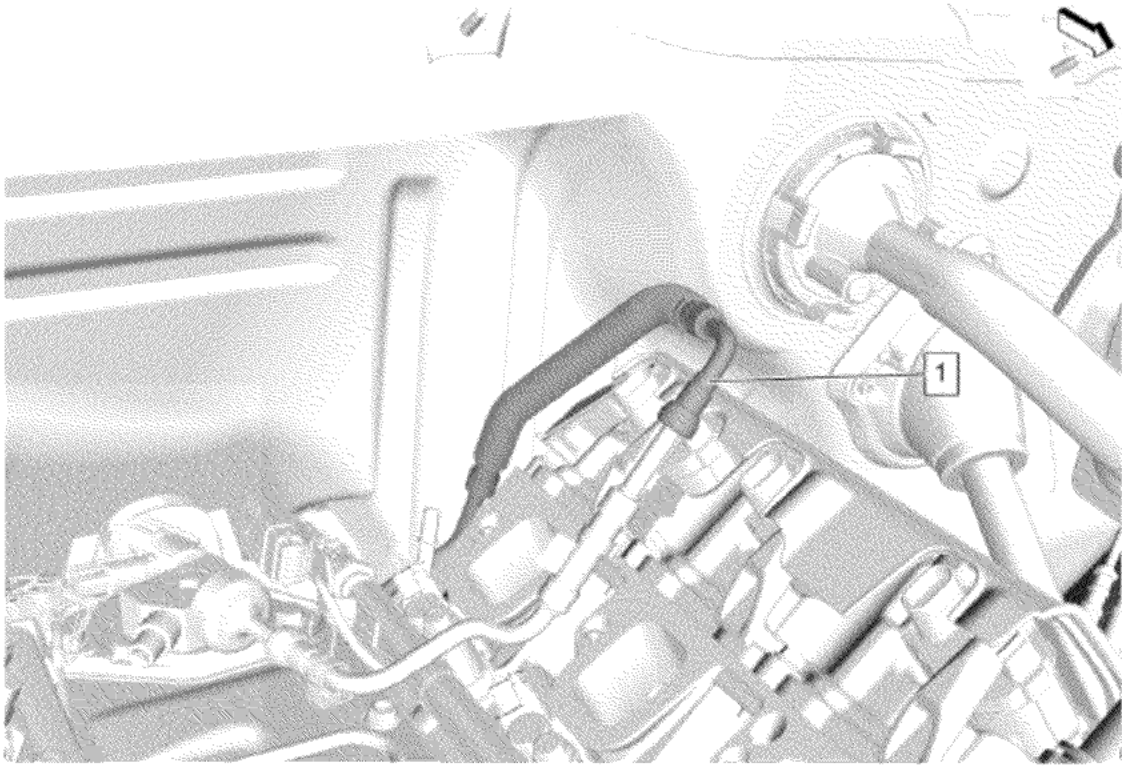

94. Fuel Feed Pipe (1) » Install

95. Fuel Feed Pipe (1) » Connect — [Metal Collar Quick Connect Fitting Service](#)

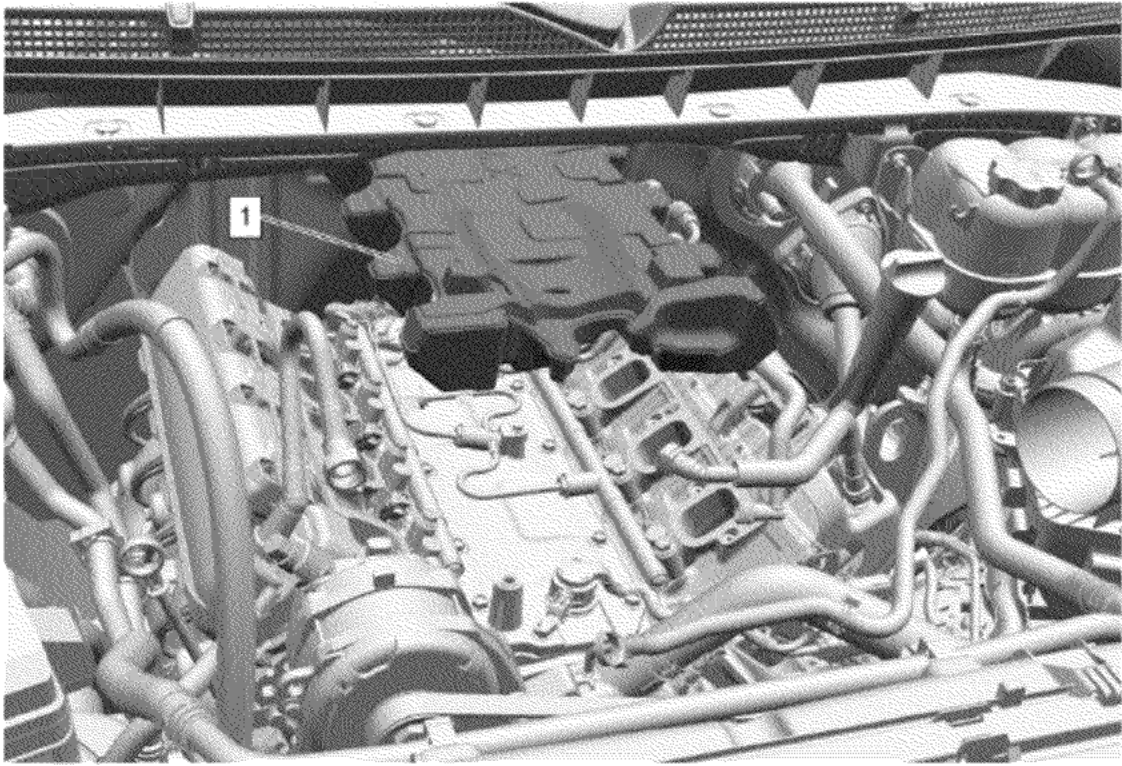

Danger: The noise cancelling foam component **MUST** be replaced if it has been exposed to engine fluids. Failure to replace the noise canceling foam component that has been exposed to engine fluids may result in an engine fire resulting in catastrophic engine damage, and possible injury or death.

96. Fuel Pump Insulator (1) » Install

97. Remove the covers from the cylinder head passages.

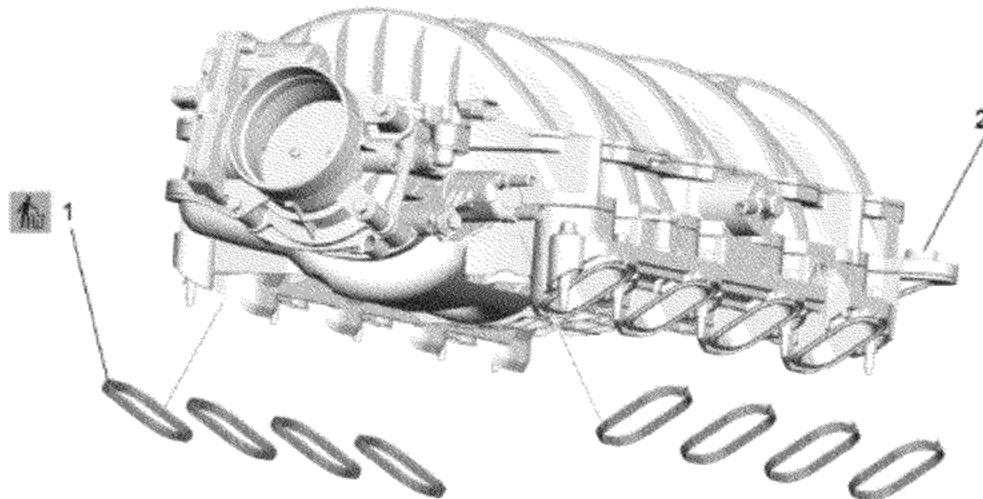

98. Intake Manifold Gasket (1) » Install NEW [8x]

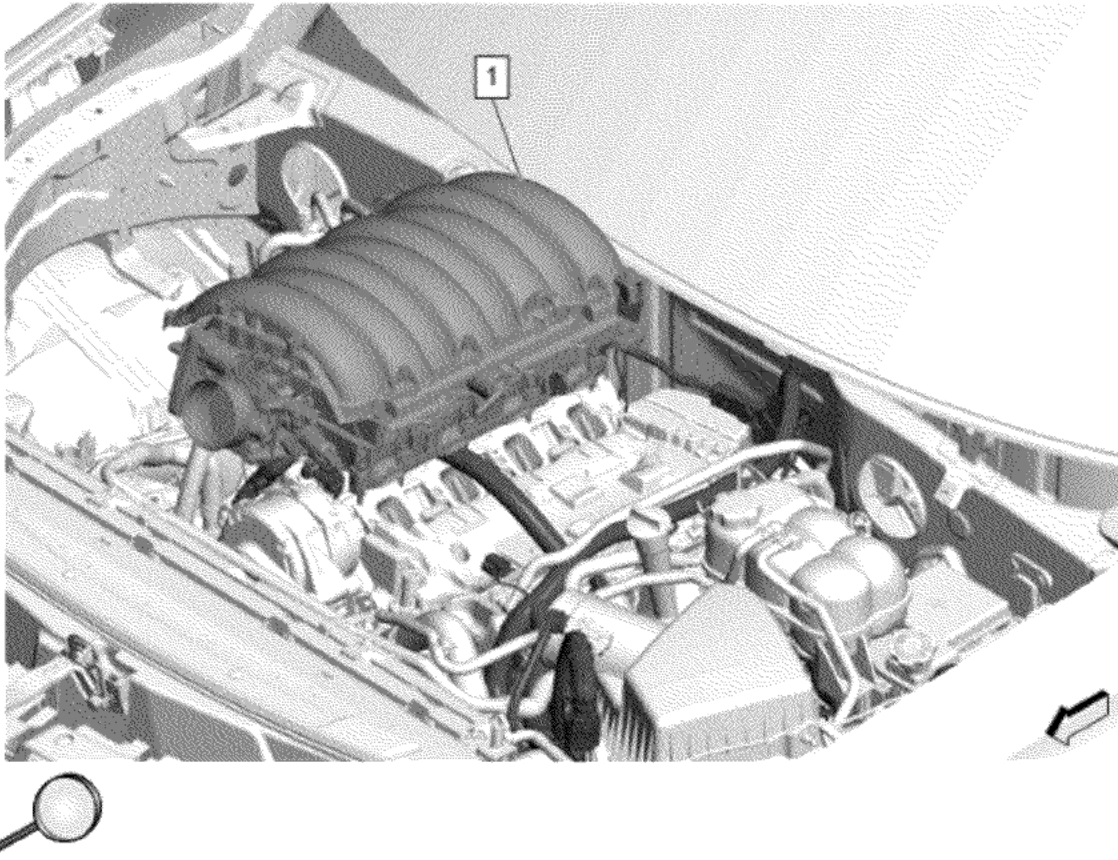

99. Clean all sealing surfaces.

100. If NEW threaded components are being installed, loosen the adhesive using a metal pick or similar tool before proceeding. If threaded components are reused, prepare the threaded components using the following steps:

100.1. Remove any loose cured adhesive from the external threads of the components using a lint free cloth.

100.2. Thread the cleaned components into the internal mating threads and remove to loosen trapped cured adhesive.

100.3. Apply thread locking adhesive to the external threads of the components. Adhesives, Fluids, Lubricants, and Sealers

100.4. Ensure there are no gaps in the thread locking adhesive once applied to the component.

Note: The aid of an assistant may be helpful in holding the engine harness up out of the way so the upper intake manifold cover does not get caught against the engine harness.

101. Position the intake manifold and Intake manifold cover (1) to install harness retainers.

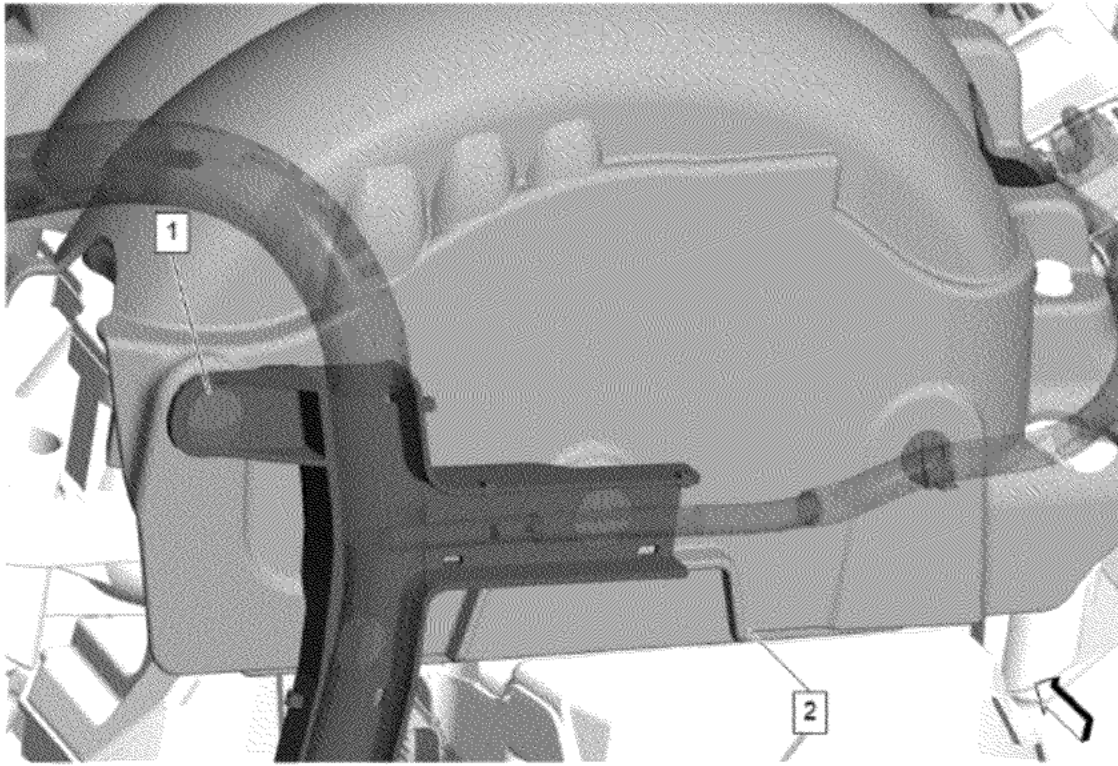

- 102. Engine Wiring Harness Retainer (1) @ Intake Manifold Cover (2) » Install [4x]
- 103. Move the intake manifold and intake manifold cover (2) into place.

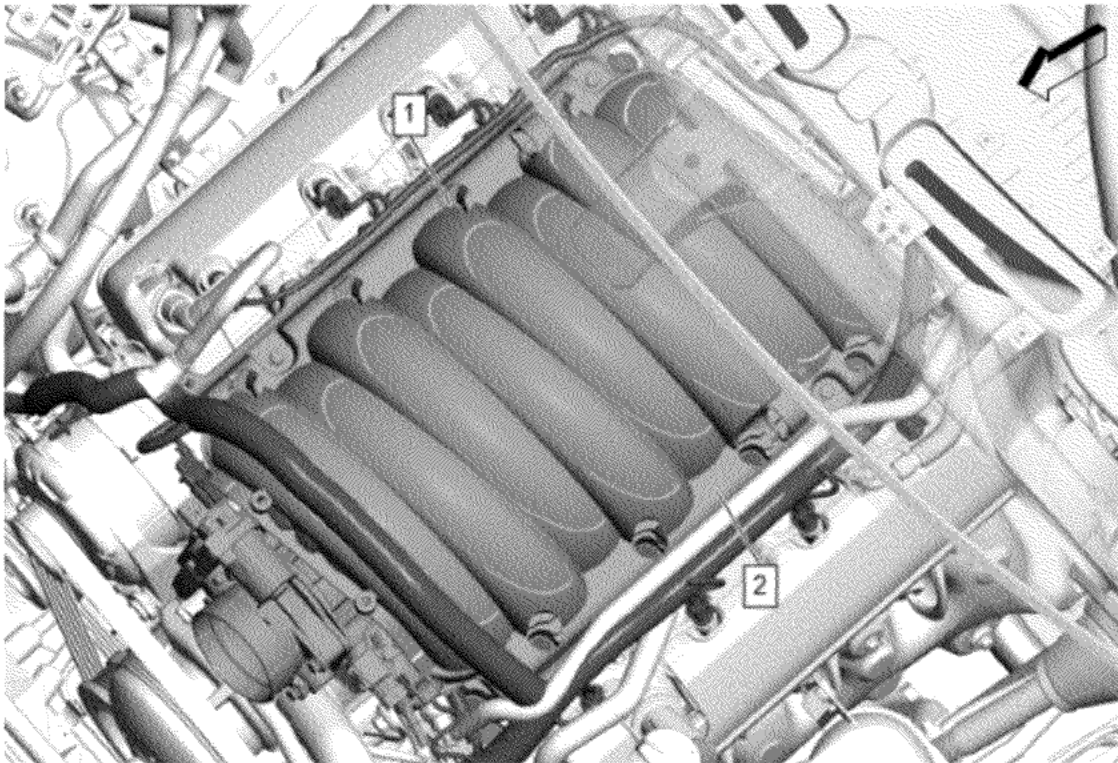

Note: Some components not shown for graphic clarity.

104. Intake Manifold Bolt (1) » Hand tighten [10x]

105. Intake Manifold Bolt (1) » Tighten in sequence [10x] — [Fastener Specifications](#)

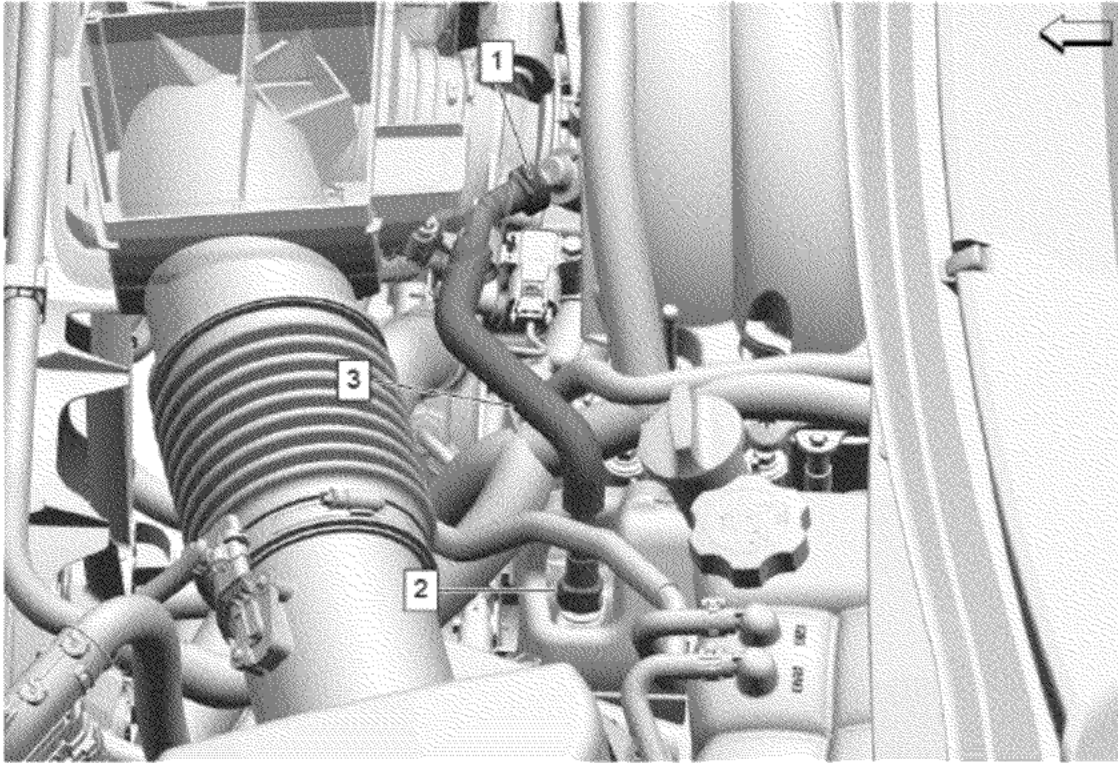

© 2025 General Motors. All rights reserved.

106. Positive Crankcase Ventilation Tube Connector (1) @ Intake Manifold » Install — [Plastic Collar Quick Connect Fitting Service](#)

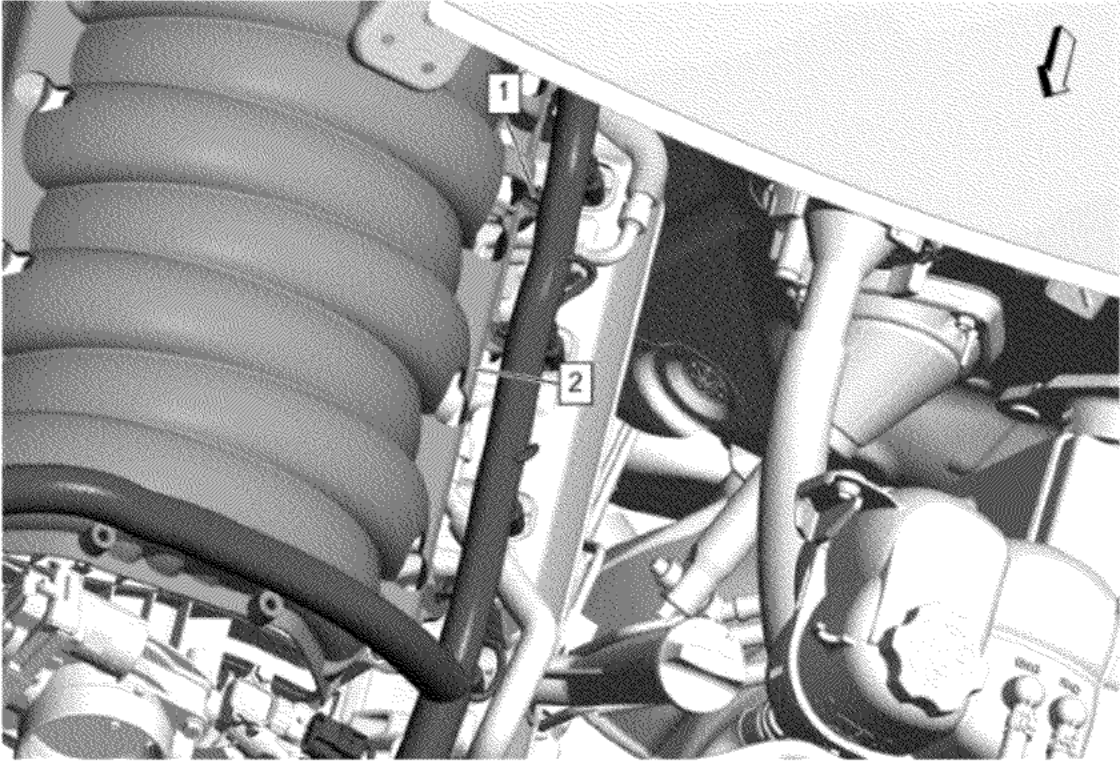

107. Engine Wiring Harness Retainer (1) @ Intake Manifold Cover (2) » Install [3x]

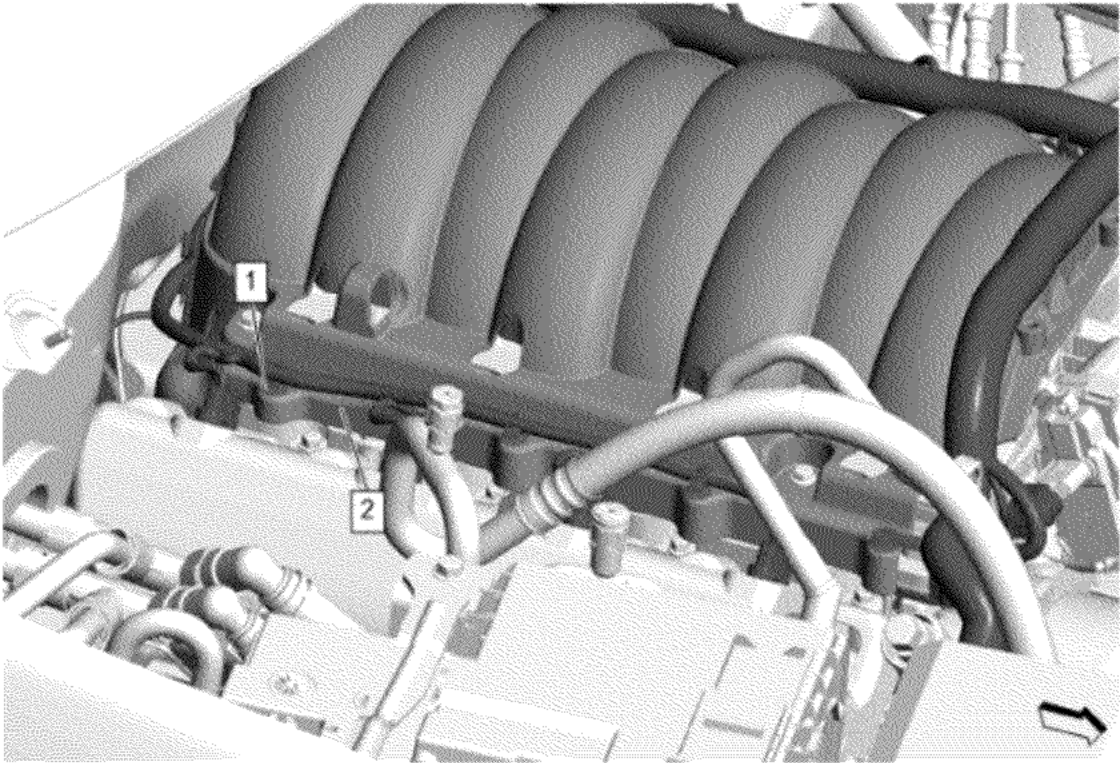

108. Engine Wiring Harness Retainer (1) @ Intake Manifold Cover (2) » Install [4x]

© 2025 General Motors. All rights reserved.

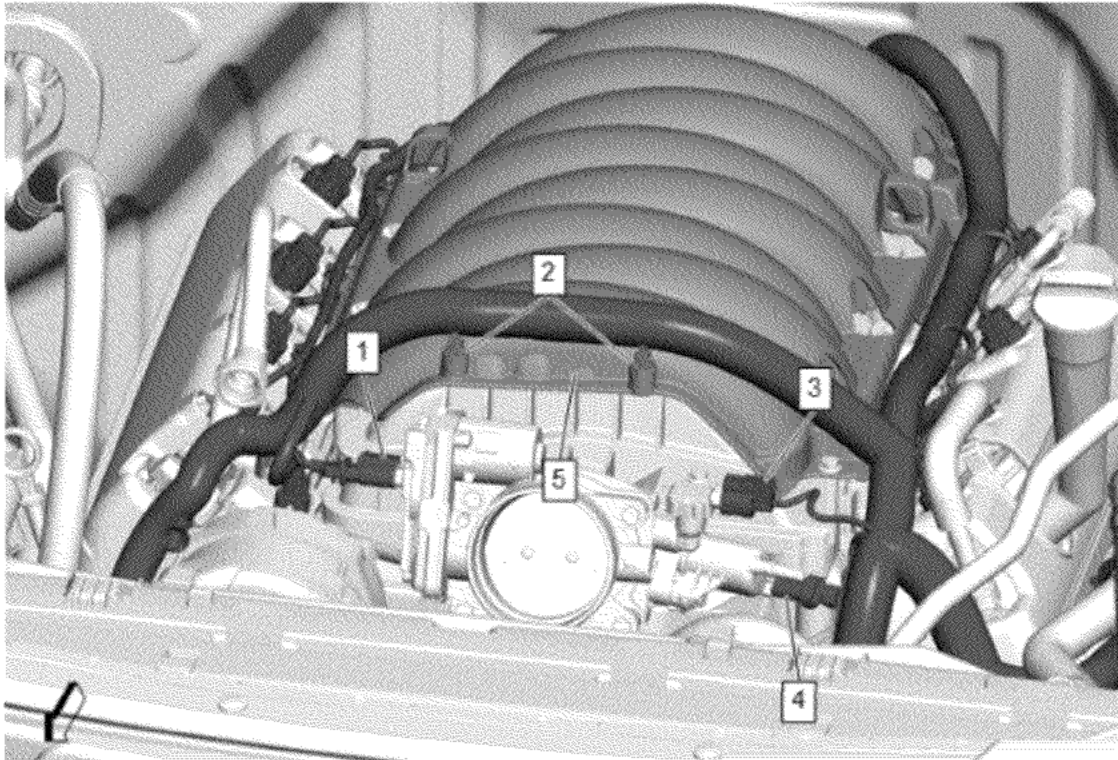

- 109. Engine Wiring Harness Connector (4) @ Evaporative Emission Canister Purge Solenoid Valve » Connect
- 110. Engine Wiring Harness Connector (3) @ Manifold Absolute Pressure Sensor » Connect
- 111. Engine Wiring Harness Retainer (2) @ Intake Manifold Cover » Install [2x]
- 112. Engine Wiring Harness Connector (1) @ Throttle Body » Connect

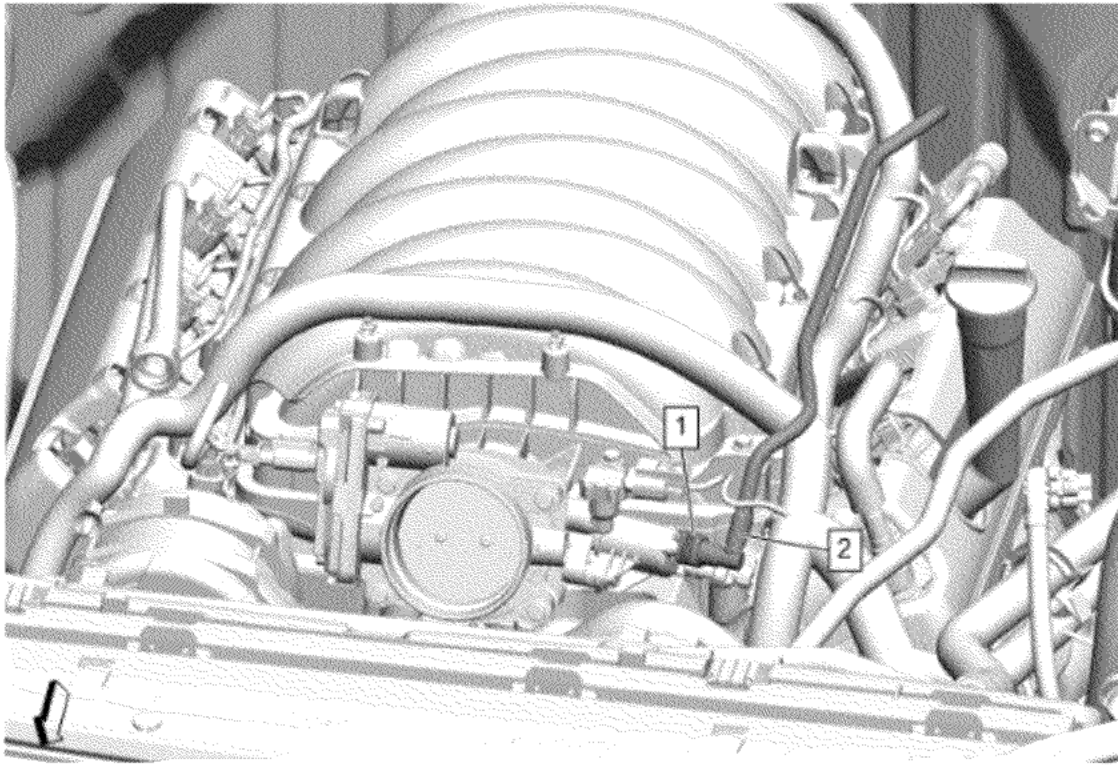

© 2025 General Motors. All rights reserved.

113. Evaporative Emission Canister Purge Tube (2) @ Evaporative Emission Canister Purge Solenoid Valve » Install

114. Evaporative Emission Canister Purge Tube Connector (1) @ Evaporative Emission Canister Purge Solenoid Valve » Engage — [Plastic Collar Quick Connect Fitting Service](#)

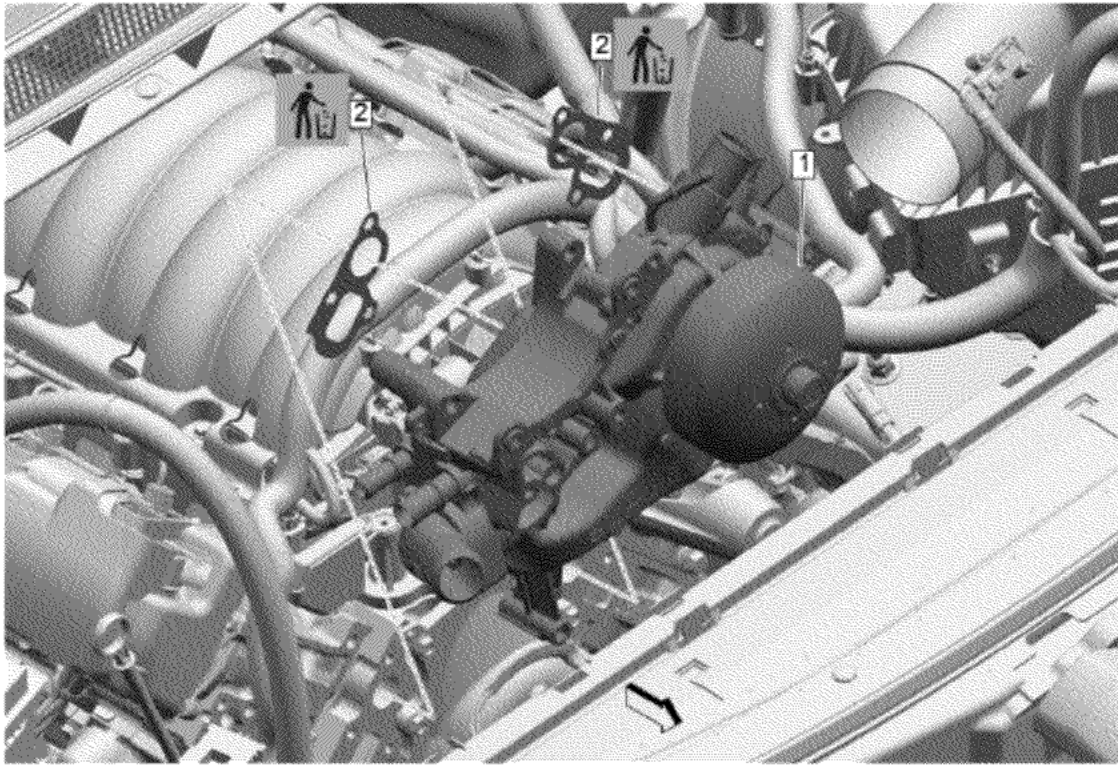

115. Water Pump Gasket (2) » Install NEW [2x]

116. Water Pump (1) » Install

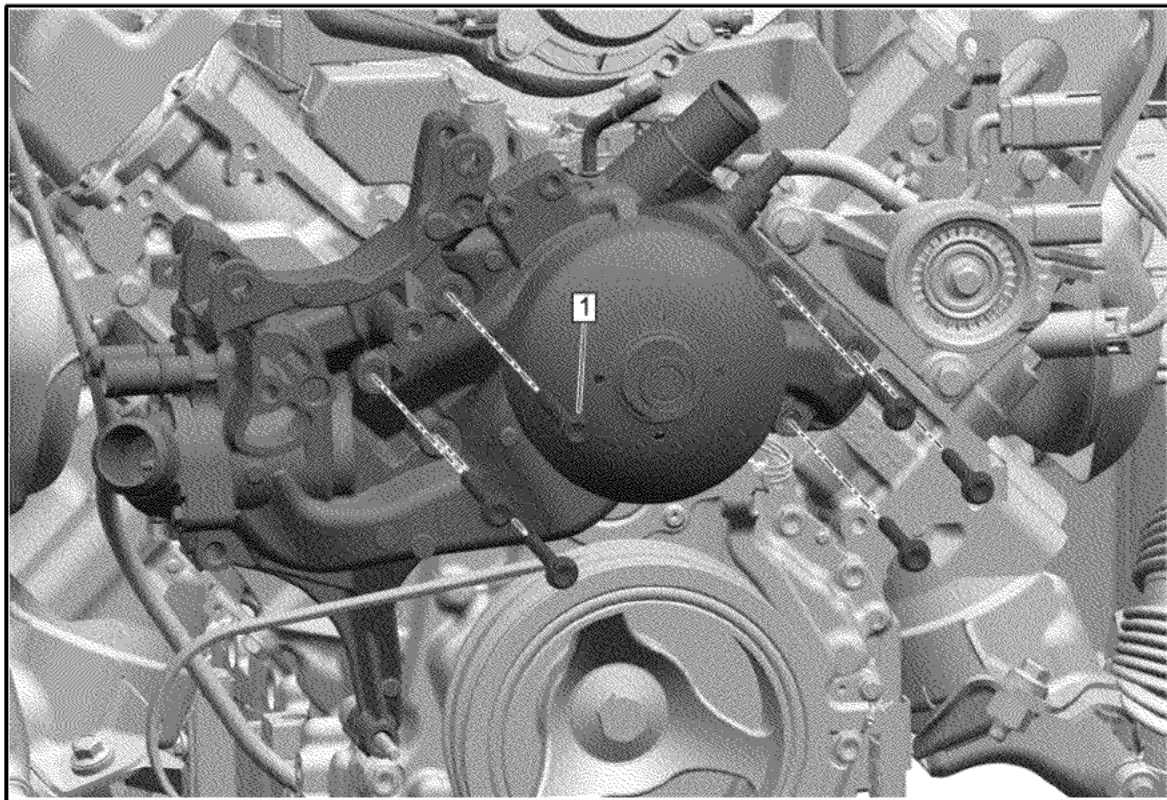

117. If NEW threaded components are being installed, loosen the adhesive using a metal pick or similar tool before proceeding. If threaded components are reused, prepare the threaded components using the following steps:
- 117.1. Remove any loose cured adhesive from the external threads of the components using a lint free cloth.
 - 117.2. Thread the cleaned components into the internal mating threads and remove to loosen trapped cured adhesive.
 - 117.3. Apply thread locking adhesive to the external threads of the components. Adhesives, Fluids, Lubricants, and Sealers
 - 117.4. Ensure there are no gaps in the thread locking adhesive once applied to the component.
118. Water Pump Housing Bolt (1) » Install and hand tighten [6x]
119. Water Pump Housing Bolt » Tighten in sequence [6x] — Fastener Specifications

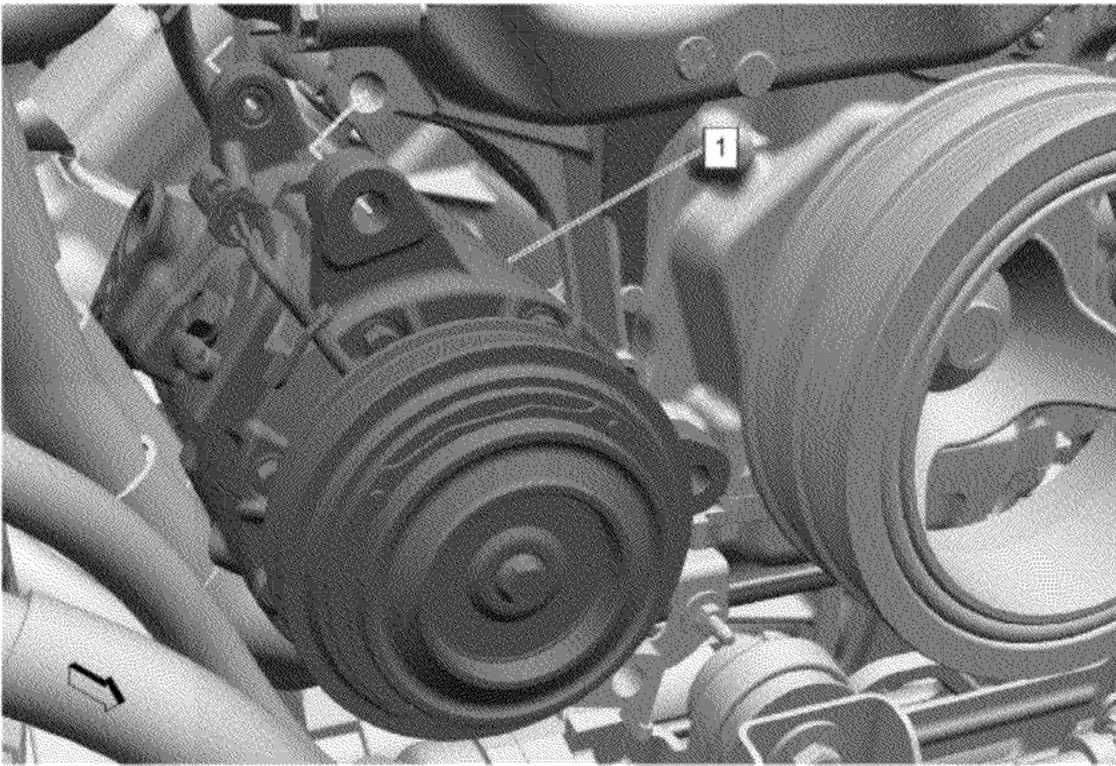

120. Air Conditioning Compressor (1) » Install

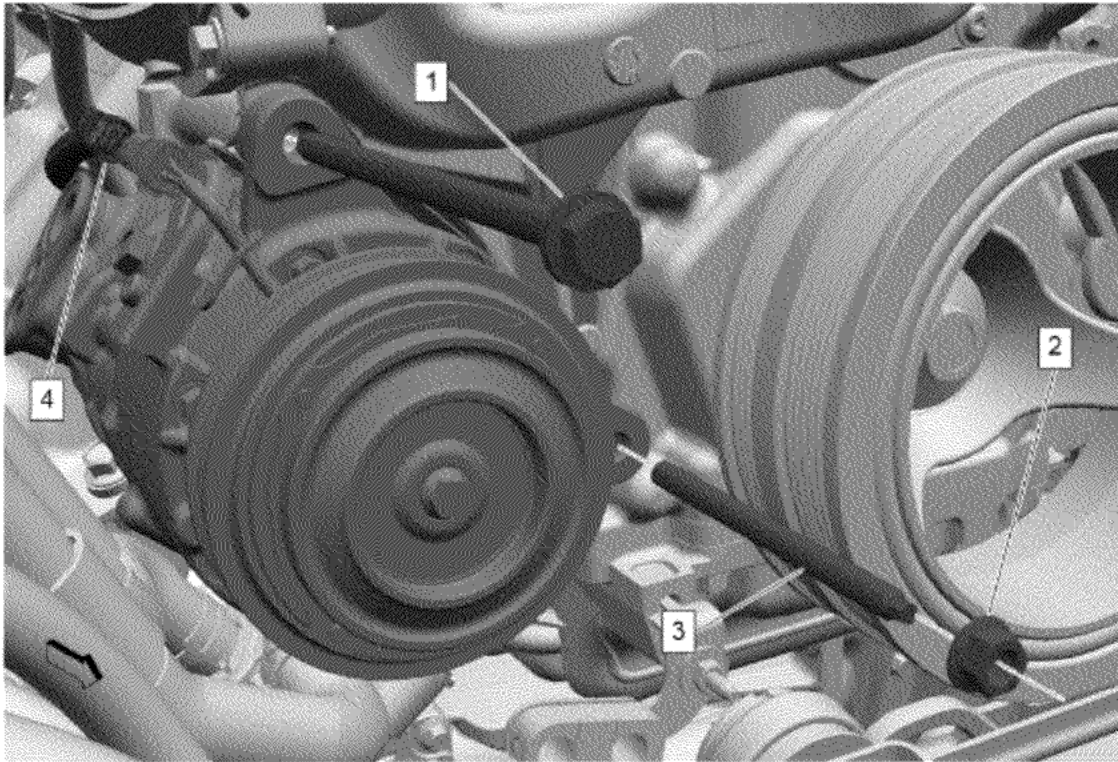

- © 2025 General Motors. All rights reserved.
- 121. Air Conditioning Compressor Bolt (1) » Loosely install
 - 122. Air Conditioning Compressor Stud (3) » Install and tighten — [Fastener Specifications](#)
 - 123. Air Conditioning Compressor Bolt (1) » Tighten — [Fastener Specifications](#)
 - 124. Air Conditioning Compressor Nut (2) » Install and tighten — [Fastener Specifications](#)

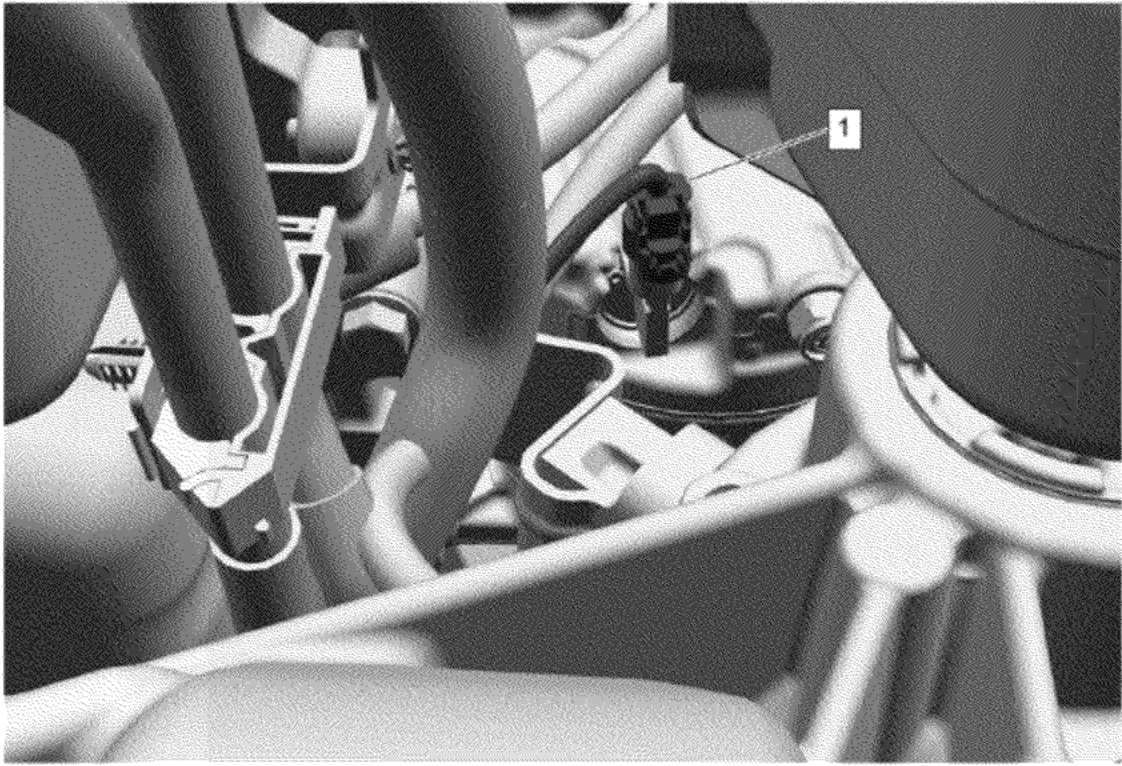

125. Electrical Connector (1) @ Air Conditioning Compressor » Connect

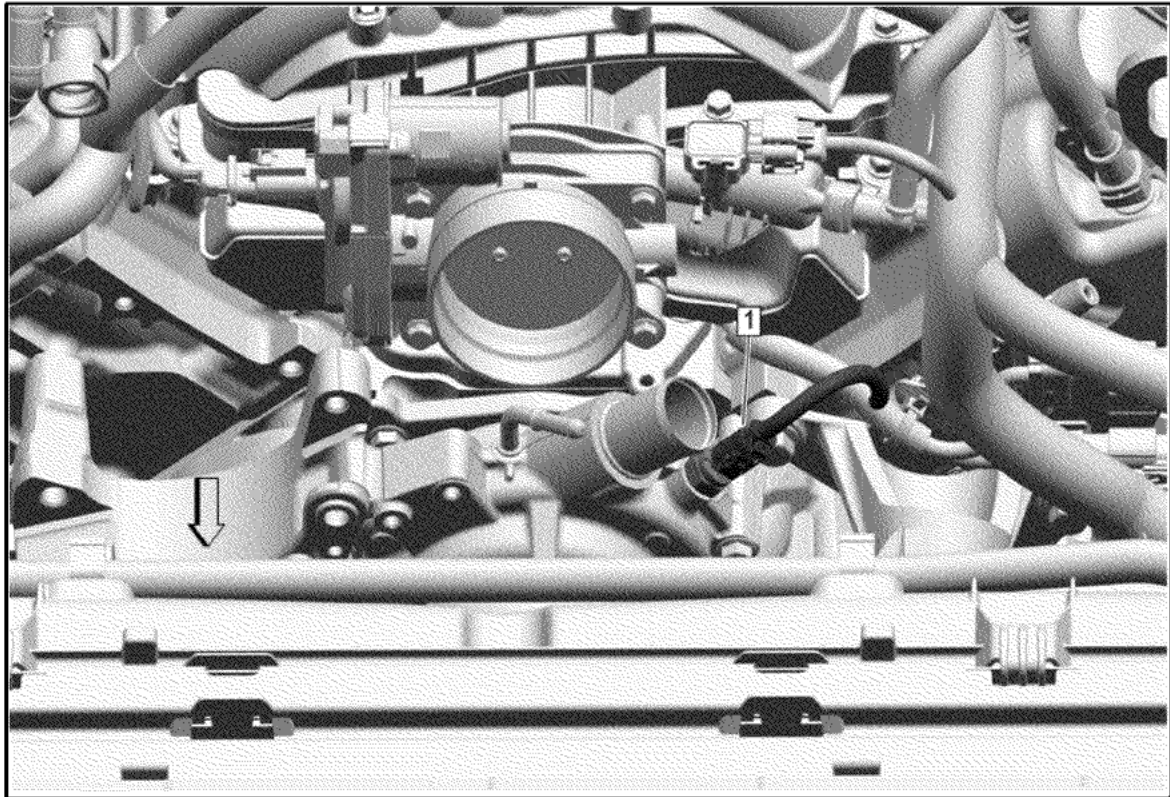

126. Engine Coolant Temperature Sensor Electrical Connector (1) » Connect

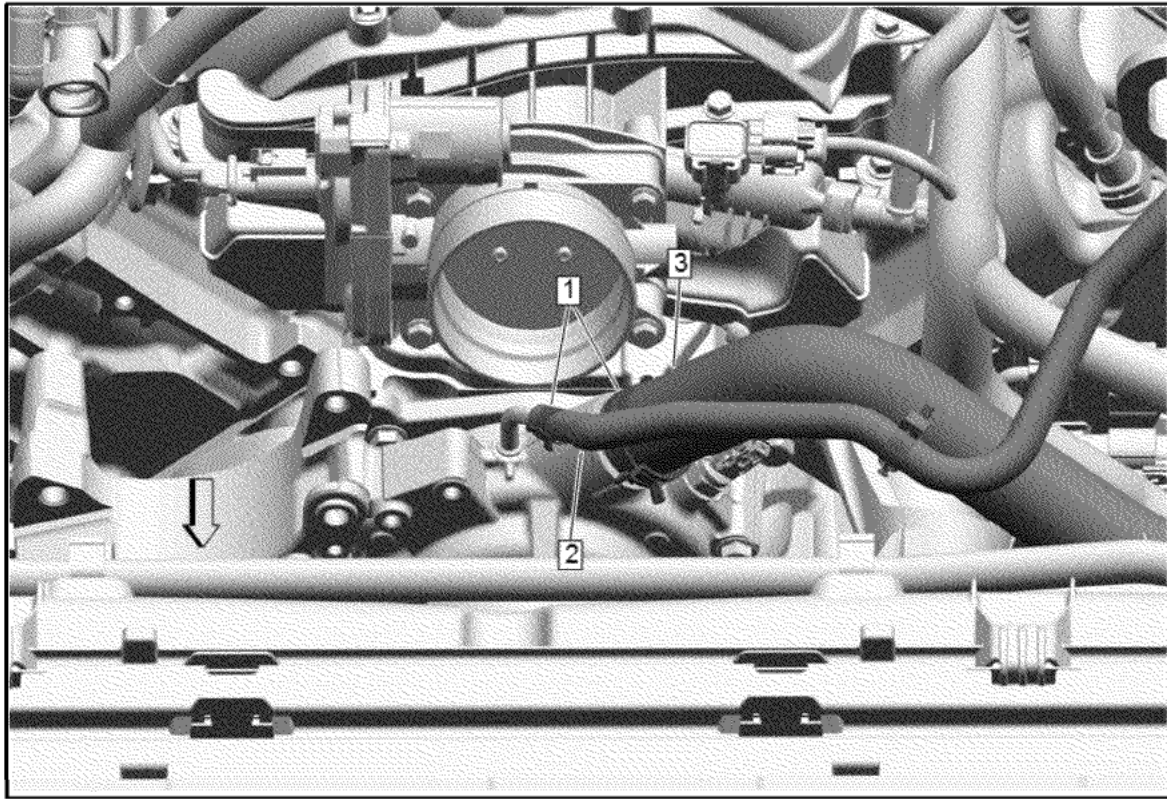

127. Radiator Inlet Hose (3) @ Water Pump » Install

128. Engine Coolant Air Bleed Hose (2) @ Water Pump » Install

129. Hose Clamp (1) » Engage [2x] — [Hose Clamp Replacement Guidelines - Spring Type](#)

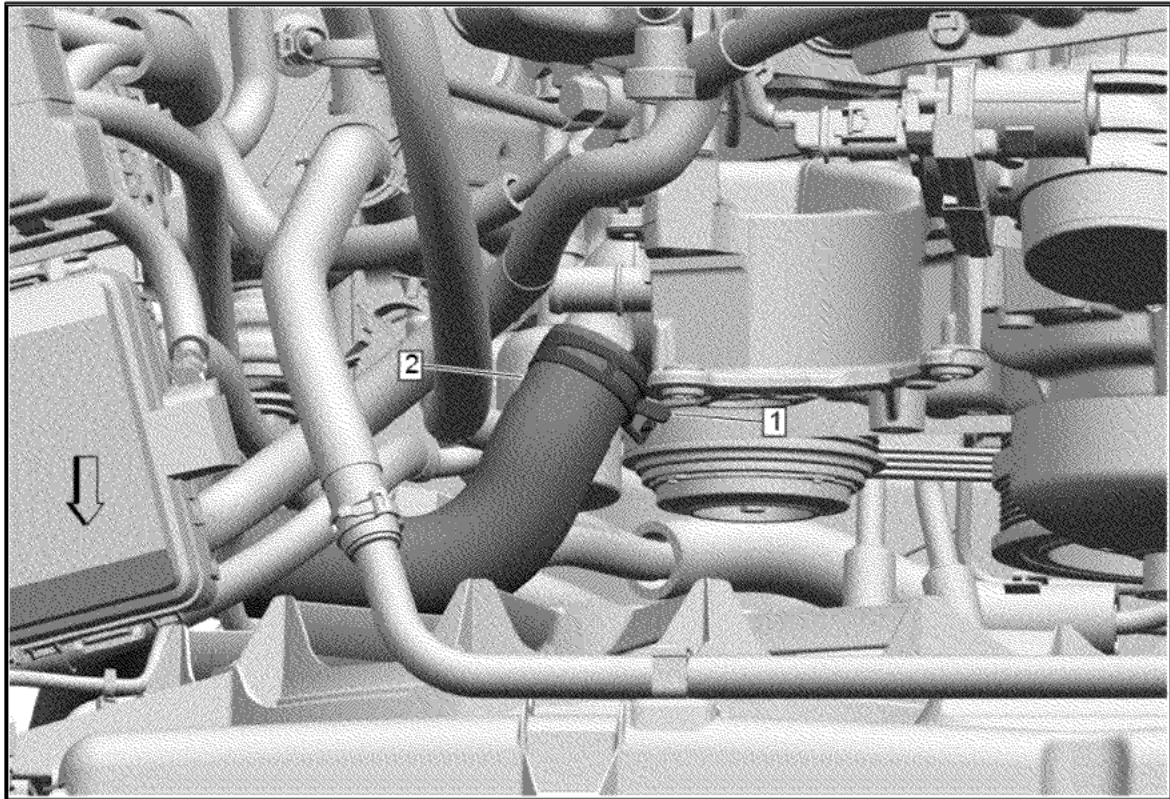

130. Radiator Outlet Hose (2) @ Water Pump » Install

131. Radiator Outlet Hose Clamp (1) » Engage — [Hose Clamp Replacement Guidelines - Spring Type](#)

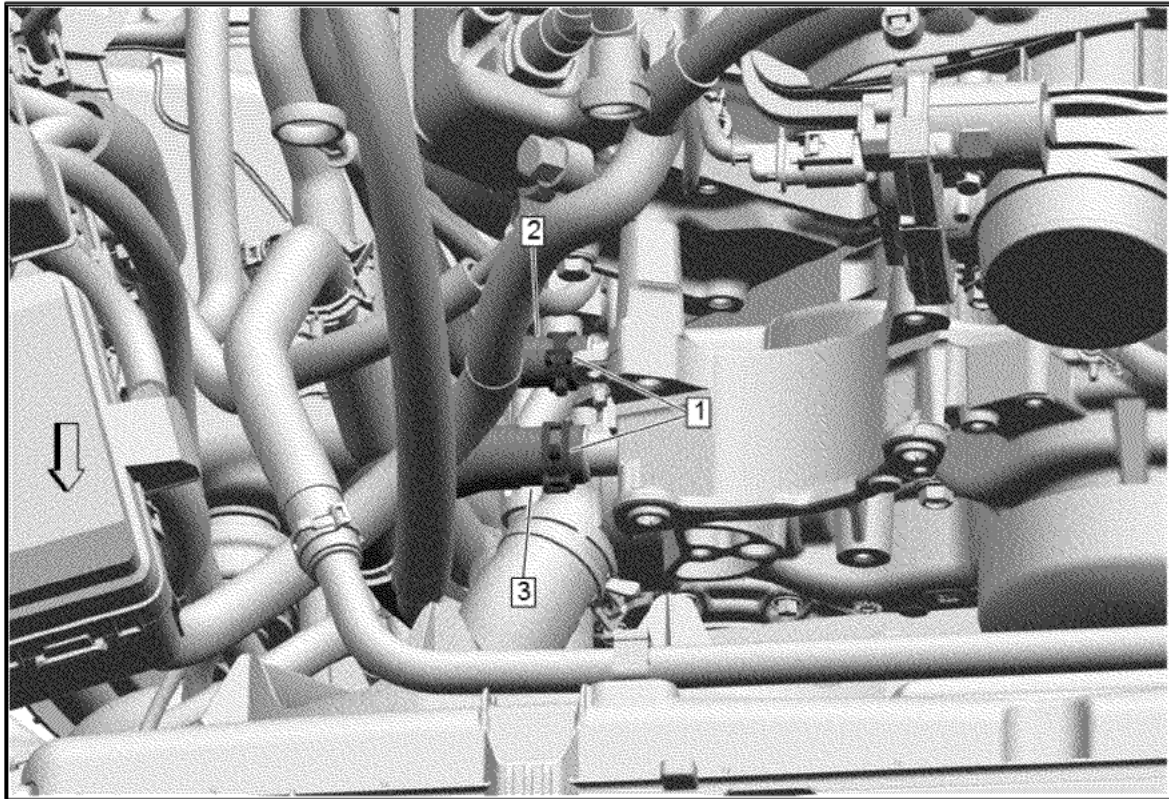

© 2025 General Motors. All rights reserved.

- 132. Heater Water Auxiliary Pump Hose (3) @ Water Pump » Install
- 133. Heater Inlet Hose (2) @ Water Pump » Install
- 134. Hose Clamp (1) » Engage [2x] — [Hose Clamp Replacement Guidelines - Spring Type](#)

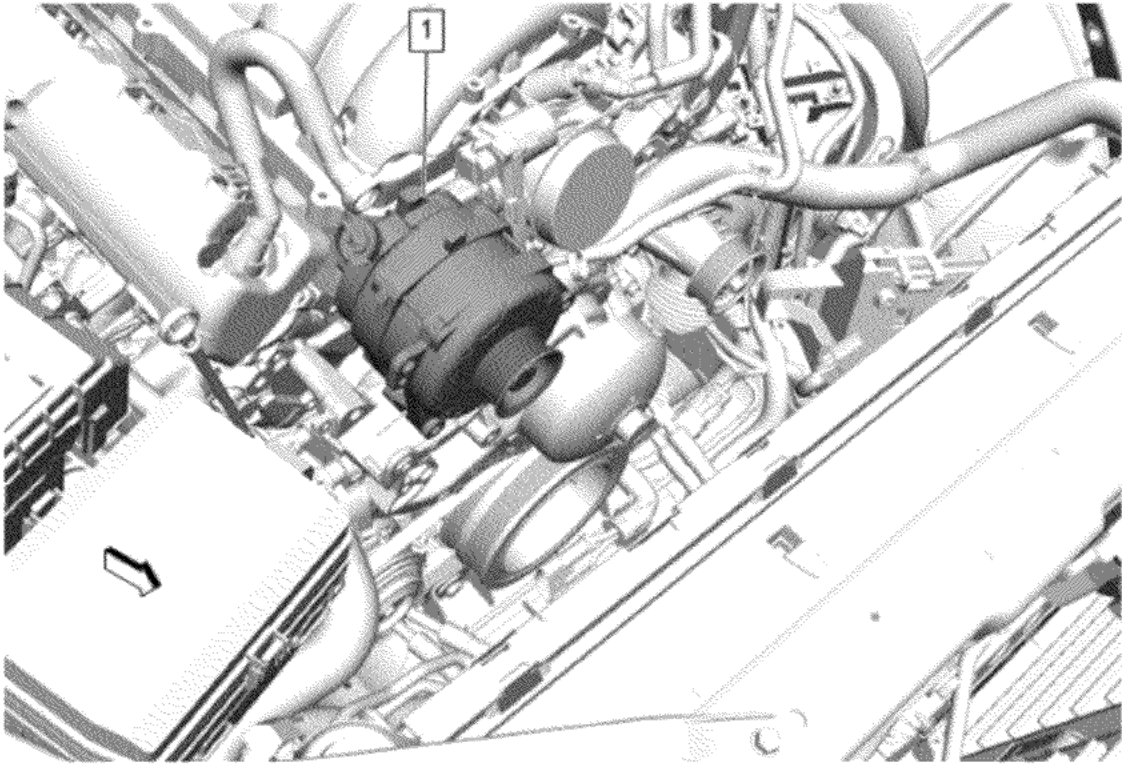

135. Generator (1) » Install

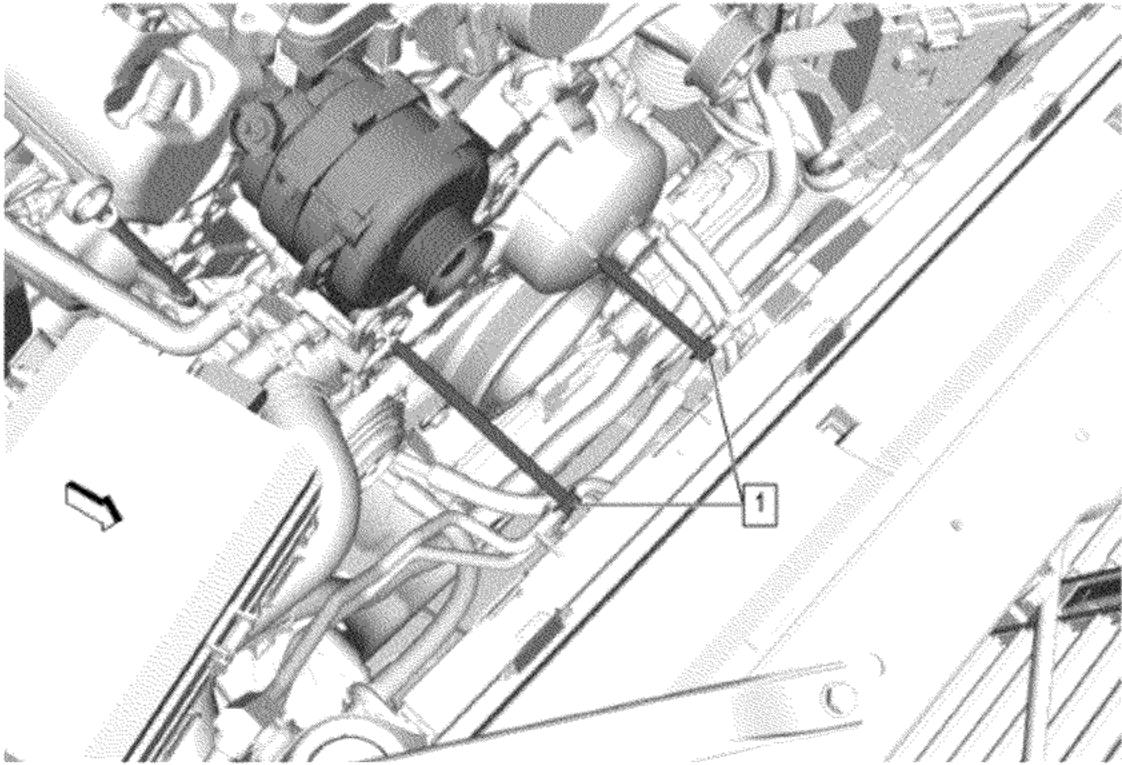

136. Generator Bolt (1) » Install and tighten [2x] — [Fastener Specifications](#)

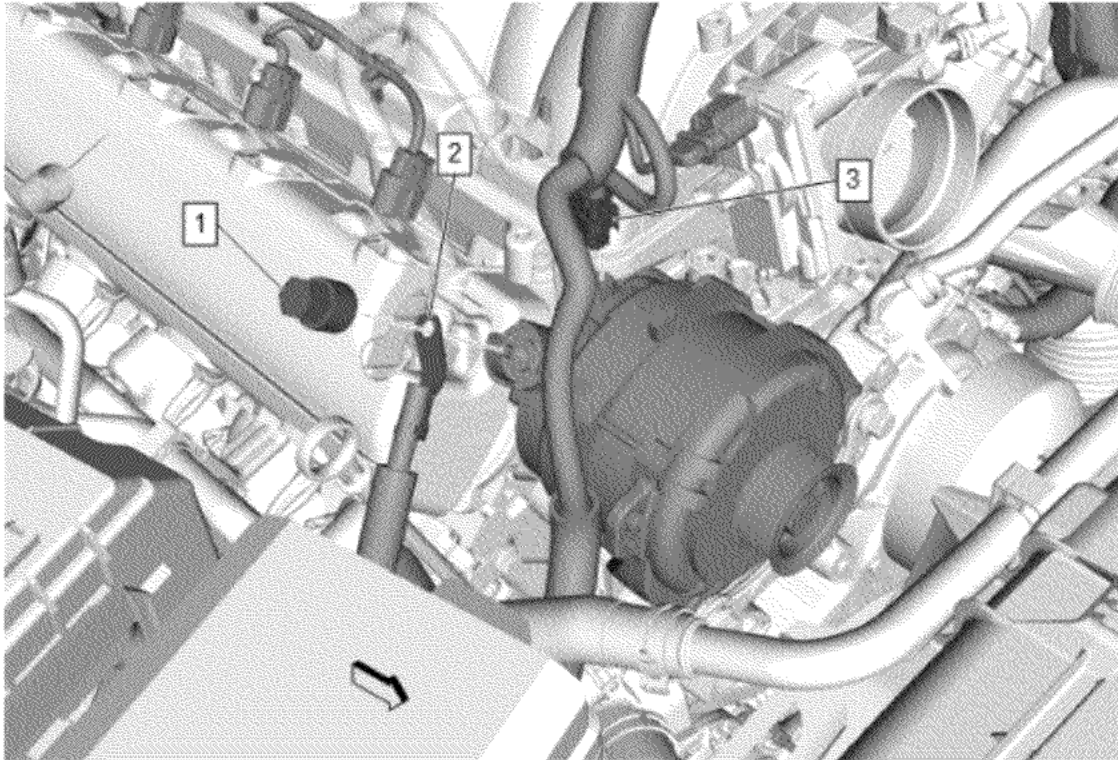

137. Starter Solenoid Cable (2) » Install

138. Battery Positive Cable Nut (1) » Install and tighten — [Fastener Specifications](#)

139. Electrical Connector (3) » Connect

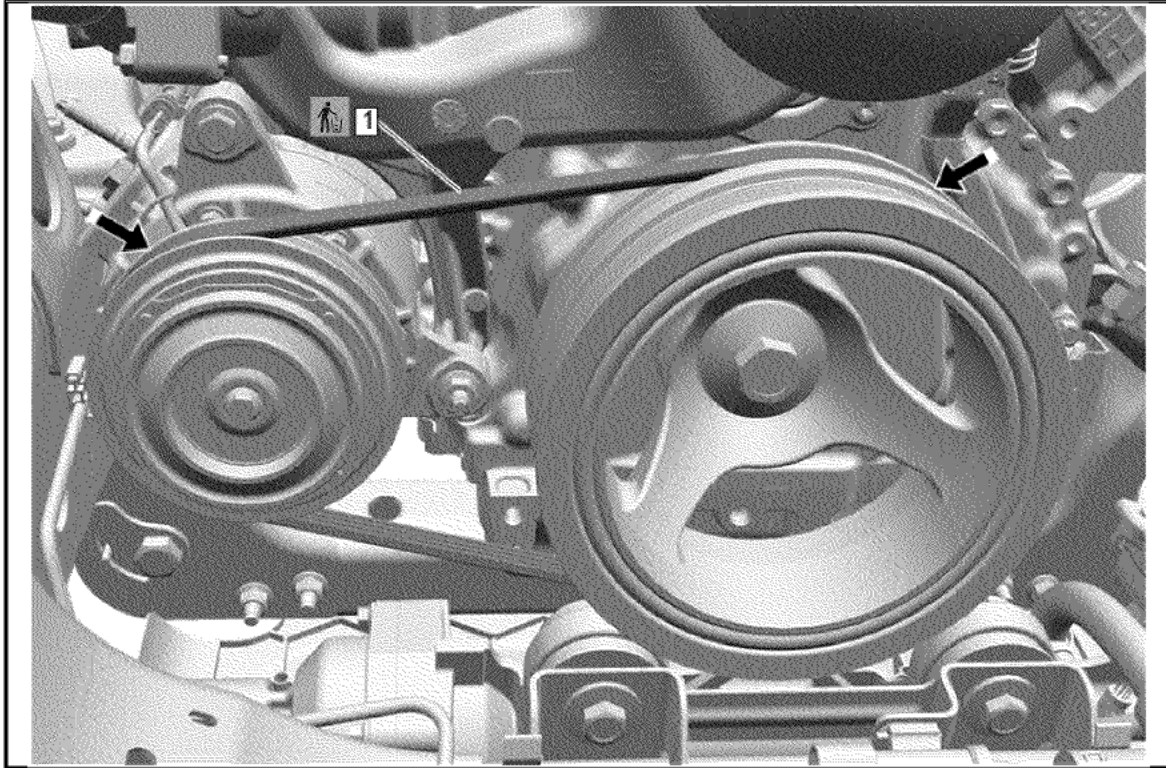

Note: The OEM replacement accessory drive auxiliary belt (1) is packaged with a disposable installation tool and installation instructions.

140. Install the accessory drive auxiliary belt (1) following the instructions included with the accessory drive auxiliary belt.
141. Inspect the accessory drive auxiliary belt (1) for proper installation and alignment.

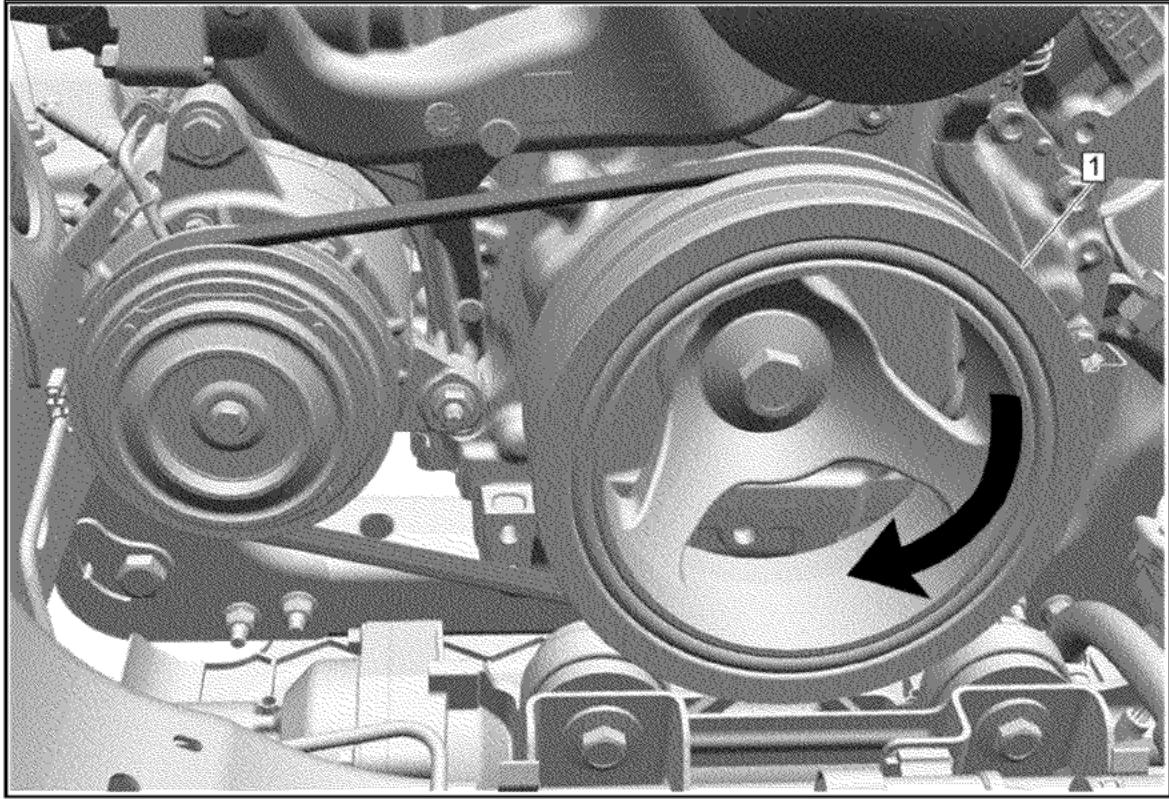

142. Rotate the crankshaft balancer (1) an additional 360 degrees to ensure proper accessory drive auxiliary belt installation.

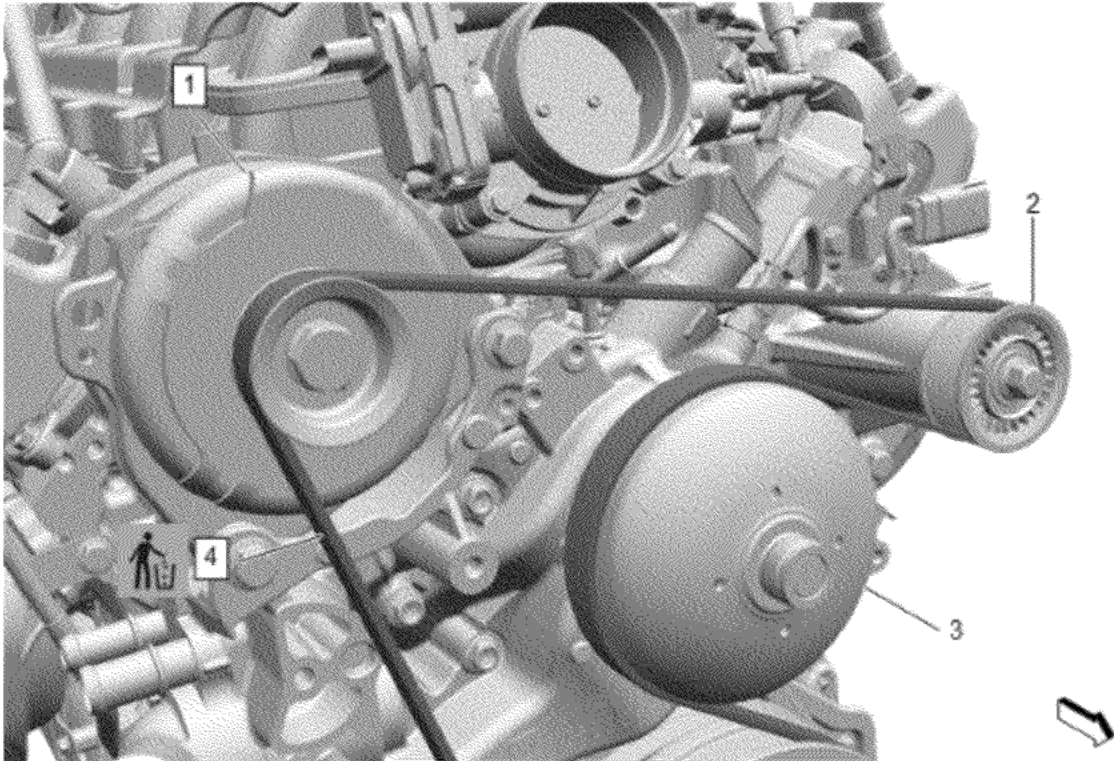

143. Position the accessory drive primary belt (4) on the belt idler pulley (2), fan and water pump pulley (3) and generator (1).

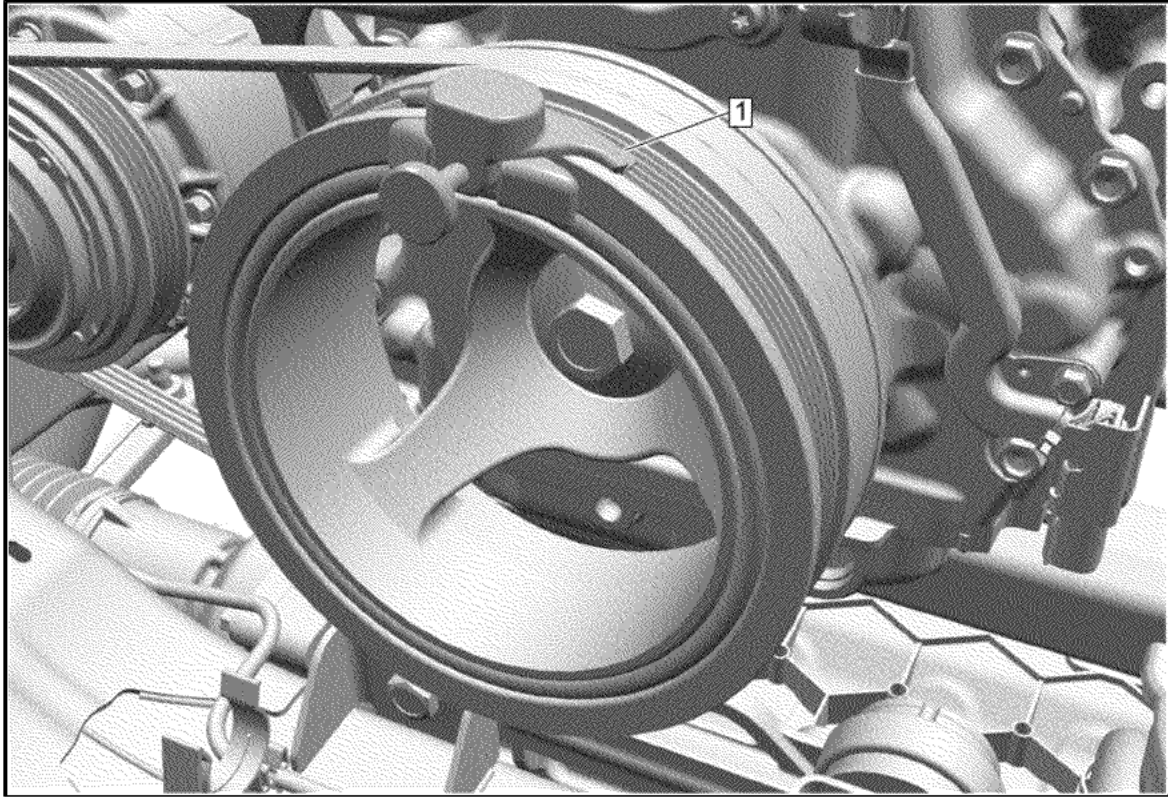

144. Install the *EN-51767-2* Stretchy Belt Installer (1) onto the crankshaft balancer.

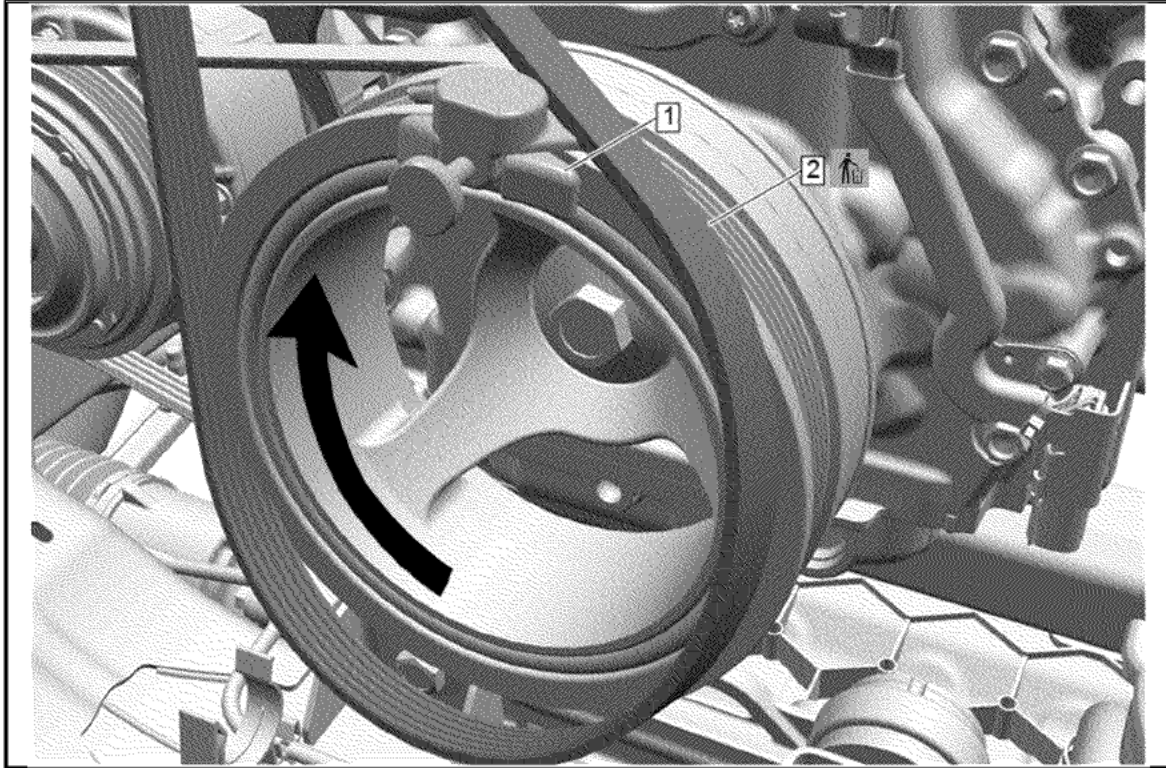

145. Position the accessory drive primary belt (2) on the crankshaft balancer.
146. Slowly rotate the crankshaft balancer in a clockwise direction until the accessory drive primary belt (2) fully seats on the crankshaft balancer.
147. Remove the *EN-51767-2* Stretchy Belt Installer (1) from the crankshaft balancer.

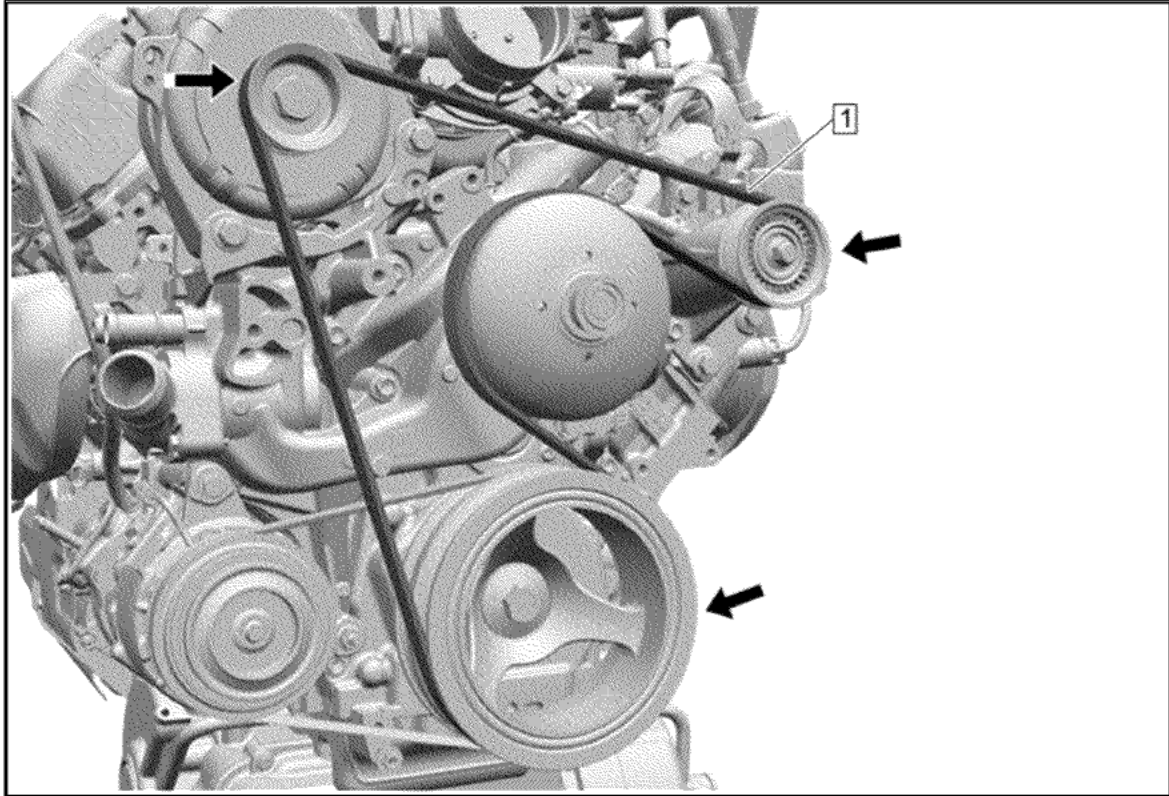

148. Inspect the accessory drive primary belt (1) for proper installation and alignment.

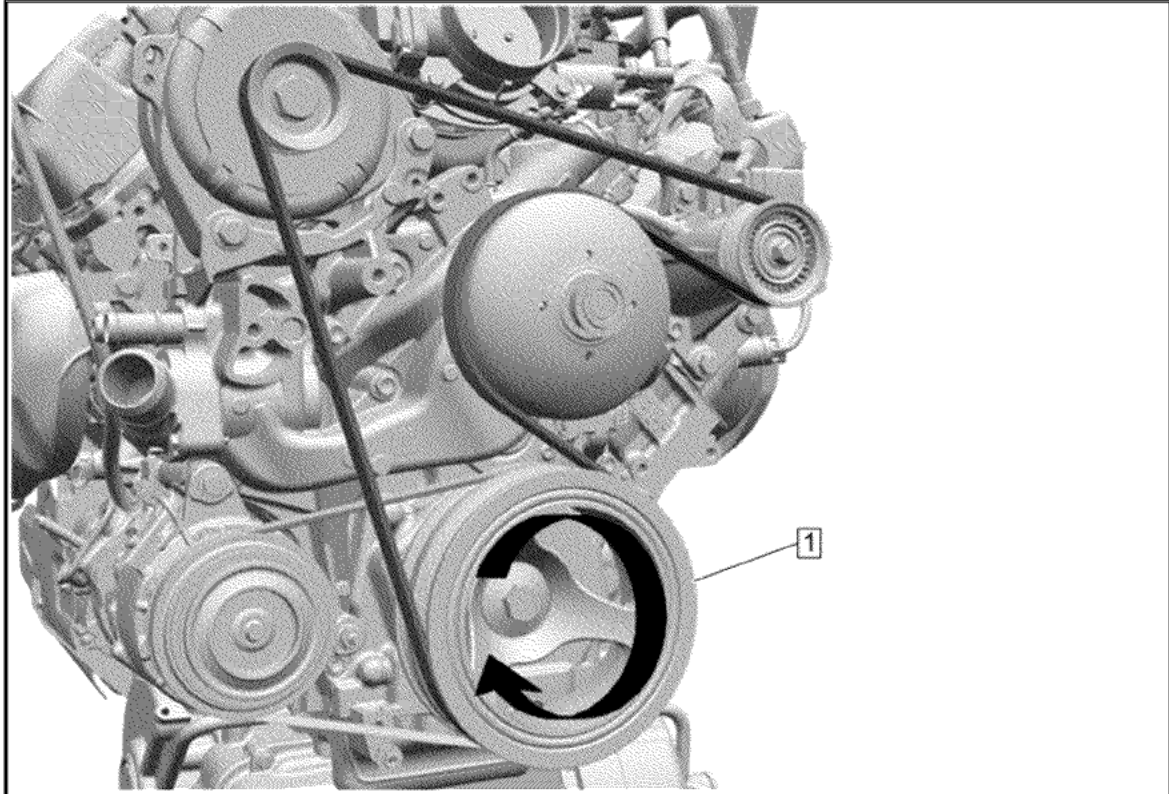

149. Rotate the crankshaft balancer (1) and additional 360 degrees to ensure proper accessory drive primary belt installation.

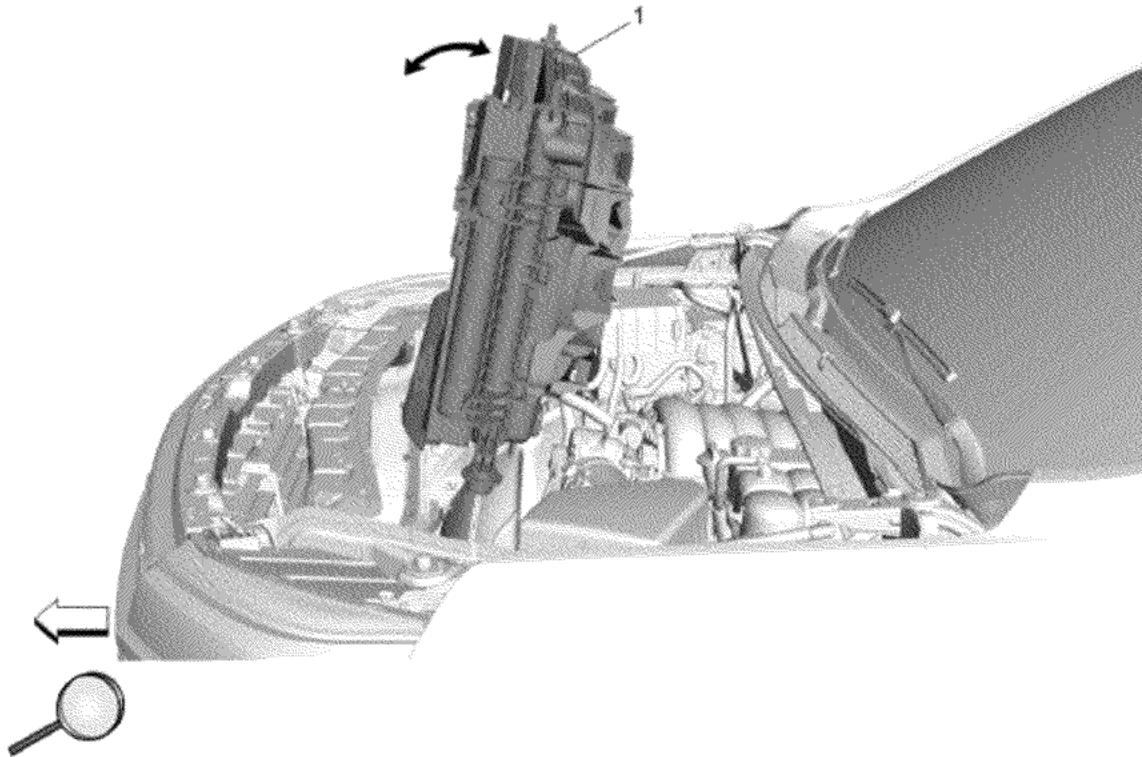

© 2025 General Motors. All rights reserved.

150. Install the condenser, fan and radiator assembly (1) into its mounts and rotate forward into place.

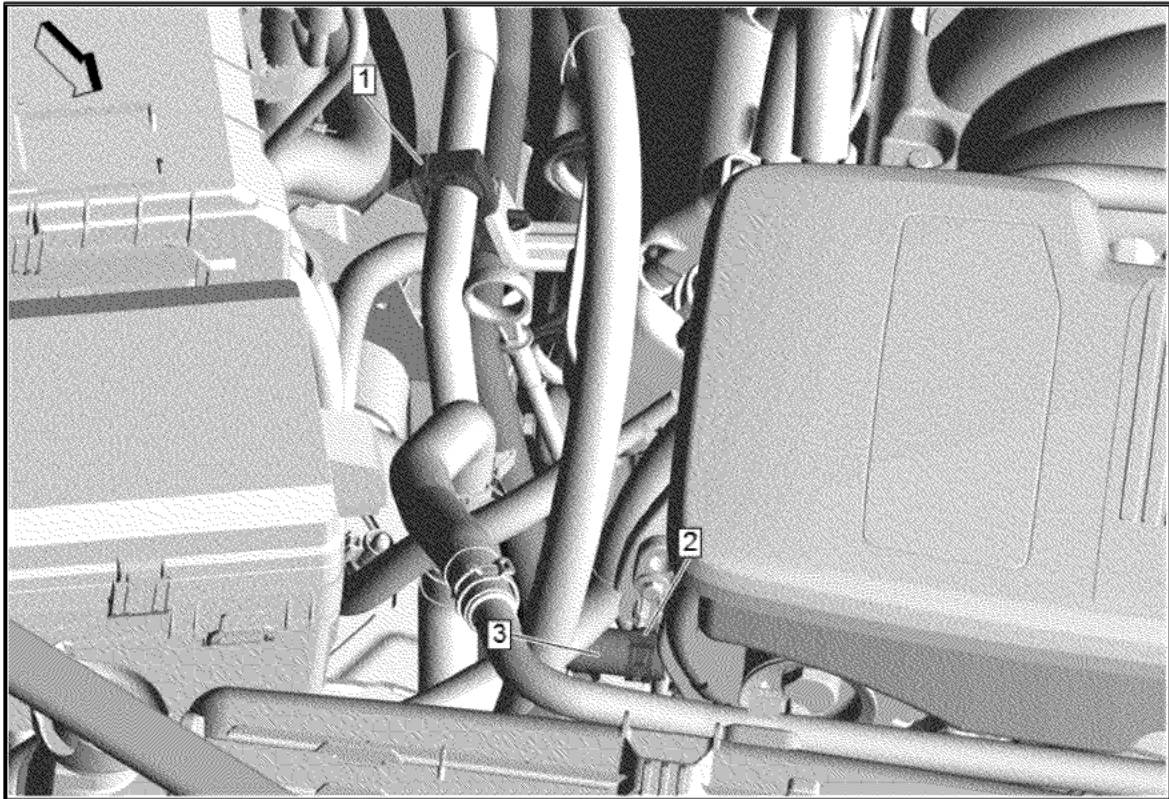

151. Heater Inlet Hose (3) @ Heater Inlet and Outlet Hose Clip (1) » Install

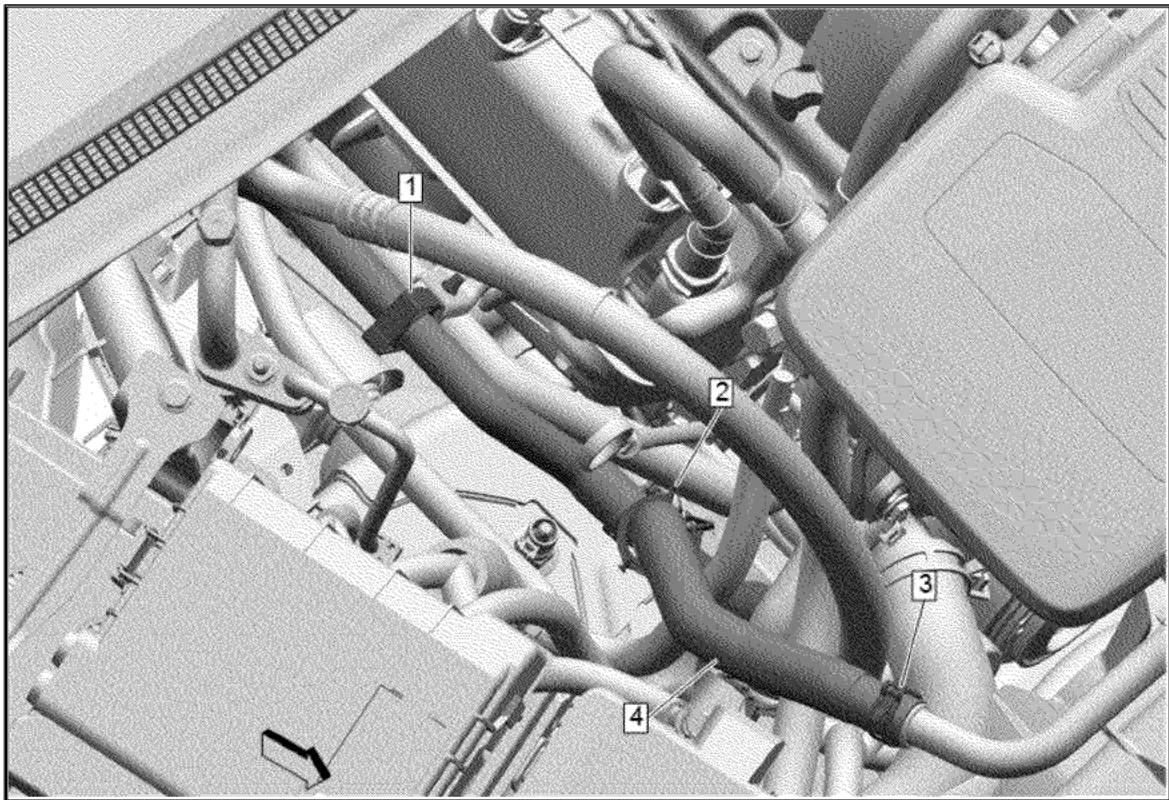

© 2025 General Motors. All rights reserved.

- 152. Heater Outlet Hose (4) @ Radiator Surge Tank Outlet Hose » Install
- 153. Heater Outlet Hose Clamp (3) » Engage — [Hose Clamp Replacement Guidelines - Spring Type](#)
- 154. Heater Outlet Hose (4) @ Clip (1) » Install
- 155. Engine Wiring Harness Clip (2) @ Heater Outlet Hose » Install

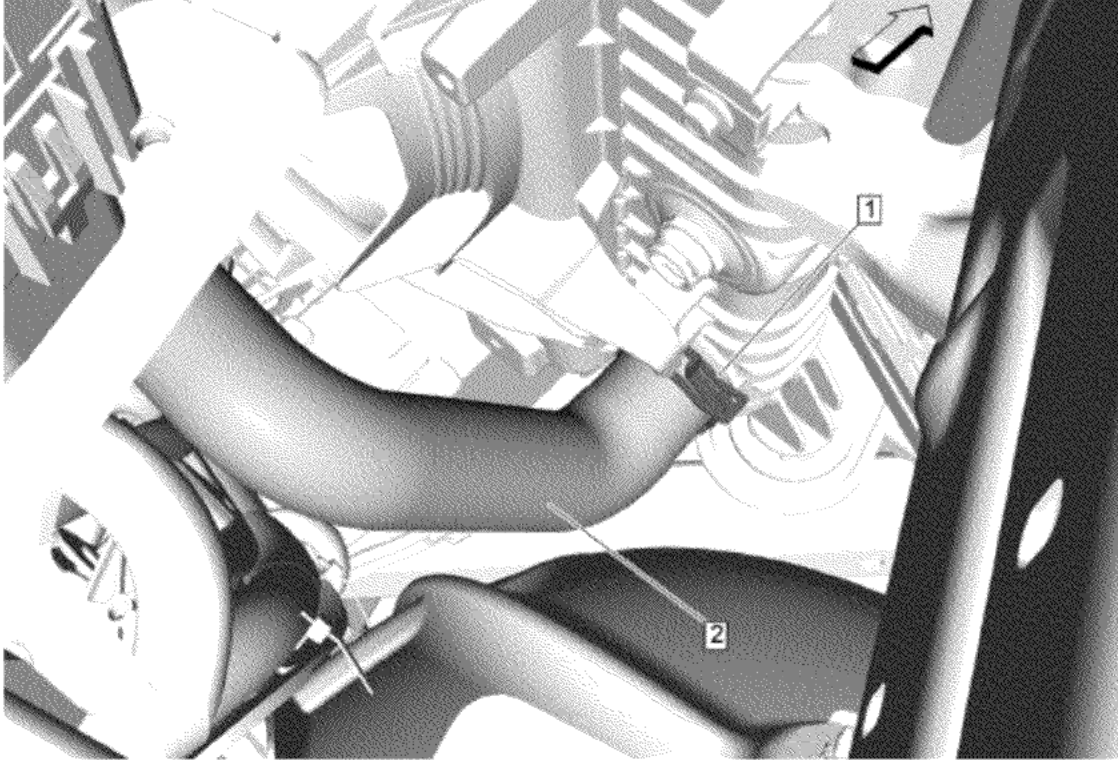

© 2025 General Motors. All rights reserved.

- 156. Radiator Outlet Hose (2) @ Engine Radiator » Install
- 157. Radiator Inlet Hose Clamp (1) » Engage — [Hose Clamp Replacement Guidelines - Spring Type](#)

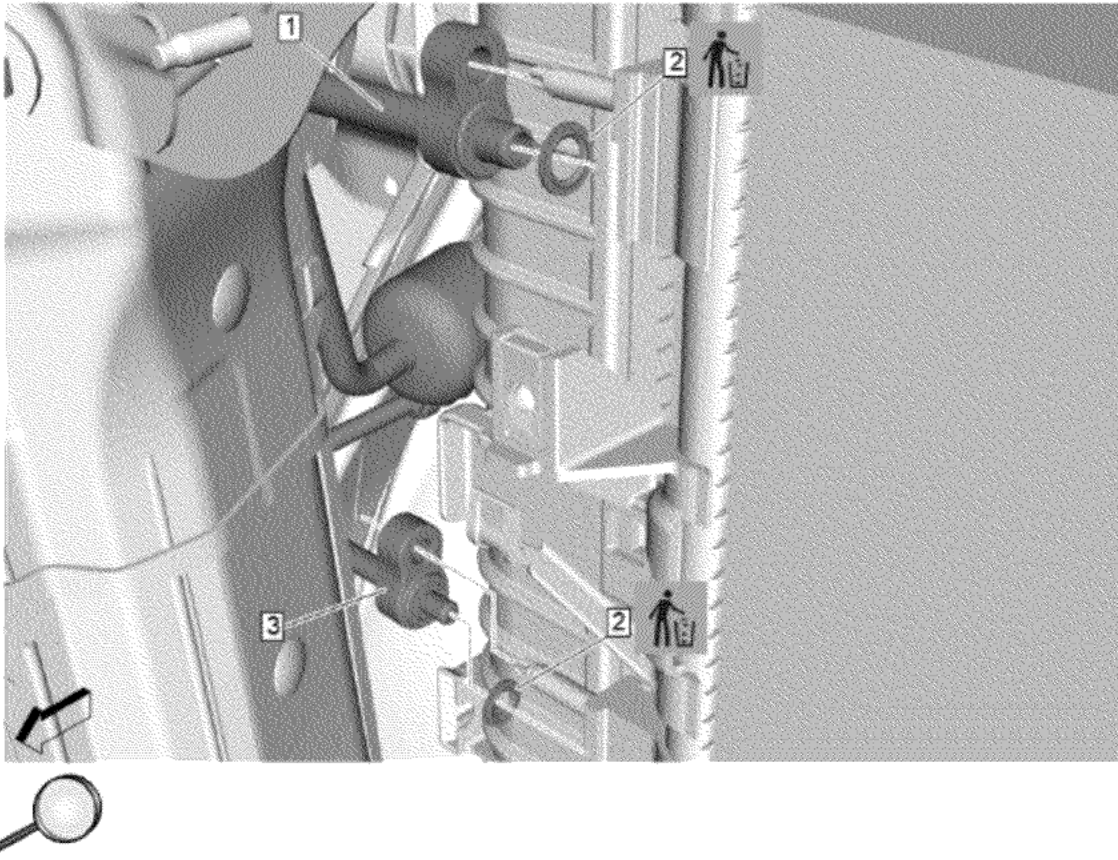

© 2025 General Motors. All rights reserved.

- Caution:** Refer to [Air Conditioning Sealing Washers Oil or Lubricant Exposure Caution](#).
- 158. Air Conditioning Compressor and Condenser Hose Seal (2) » Install NEW [2x]
 - 159. Air Conditioning Condenser and Evaporator Hose (3) @ Air Conditioning Condenser » Install
 - 160. Air Conditioning Compressor and Condenser Hose (1) @ Air Conditioning Condenser » Install

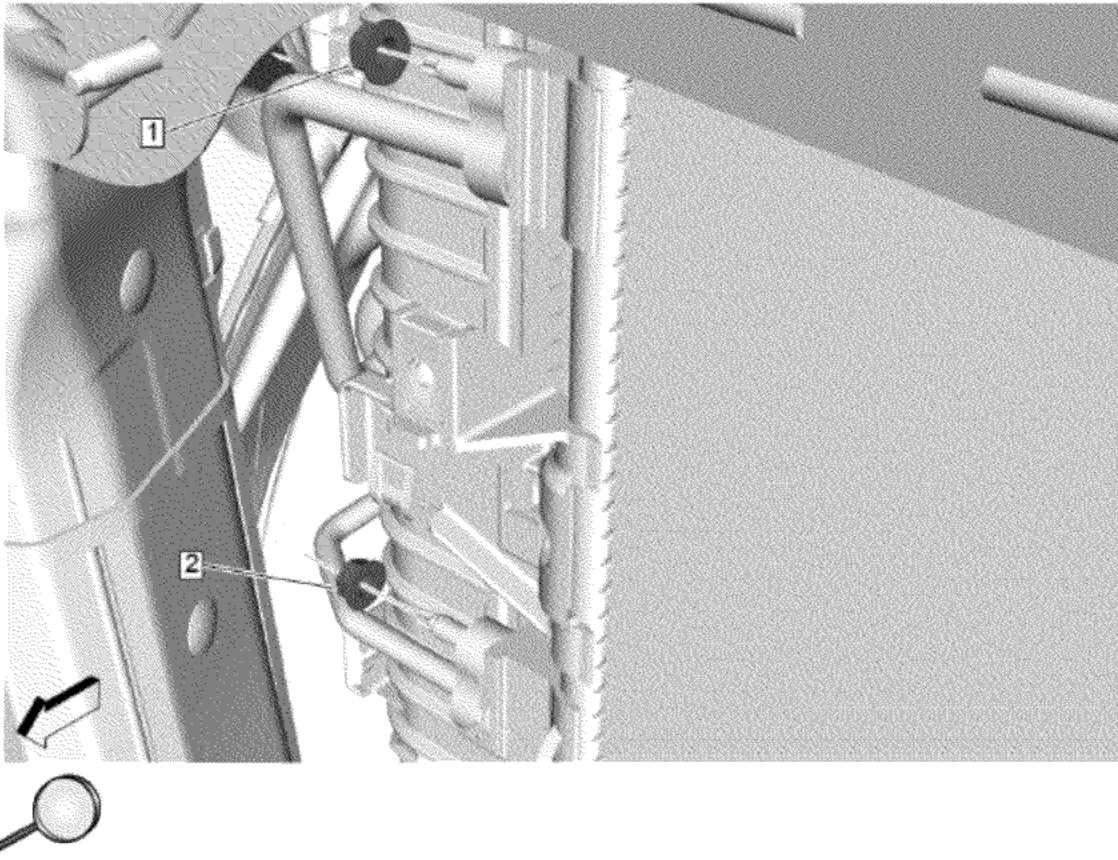

161. Air Conditioning Condenser and Evaporator Hose Nut (2) » Install and tighten — [Fastener Specifications](#)
162. Air Conditioning Compressor and Condenser Hose Nut (1) » Install and tighten — [Fastener Specifications](#)

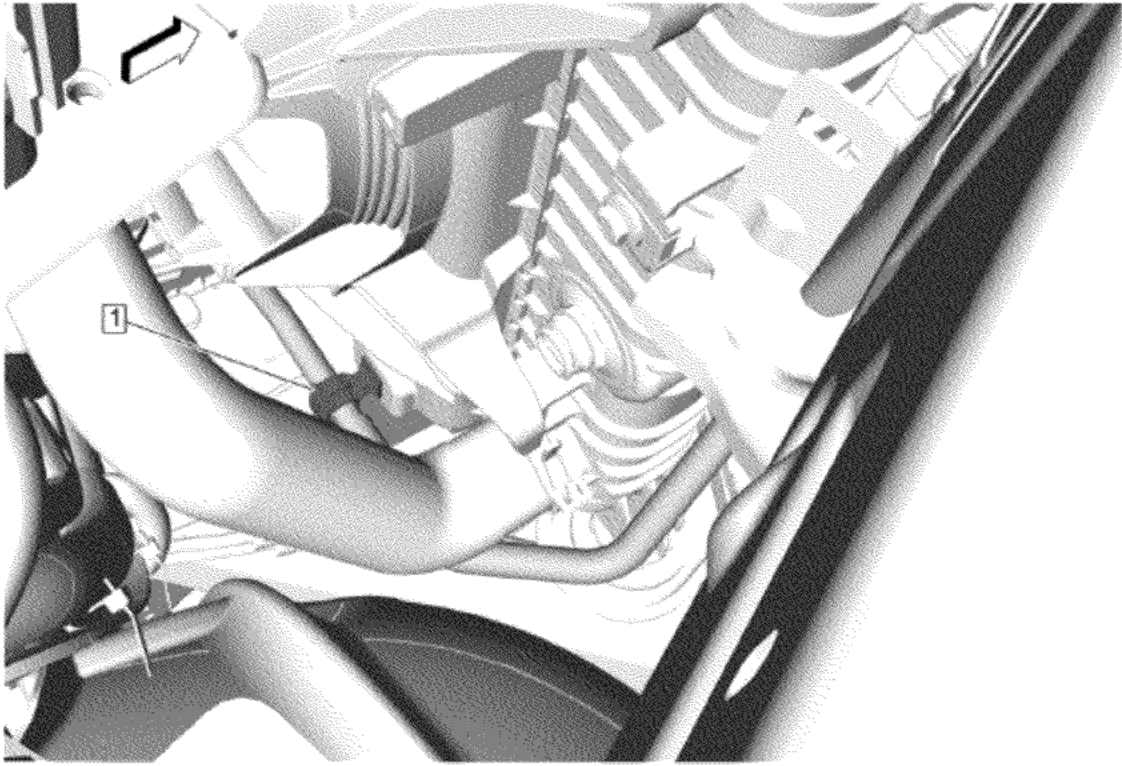

163. Transmission Fluid Cooler Pipe Clip (1) » Secure

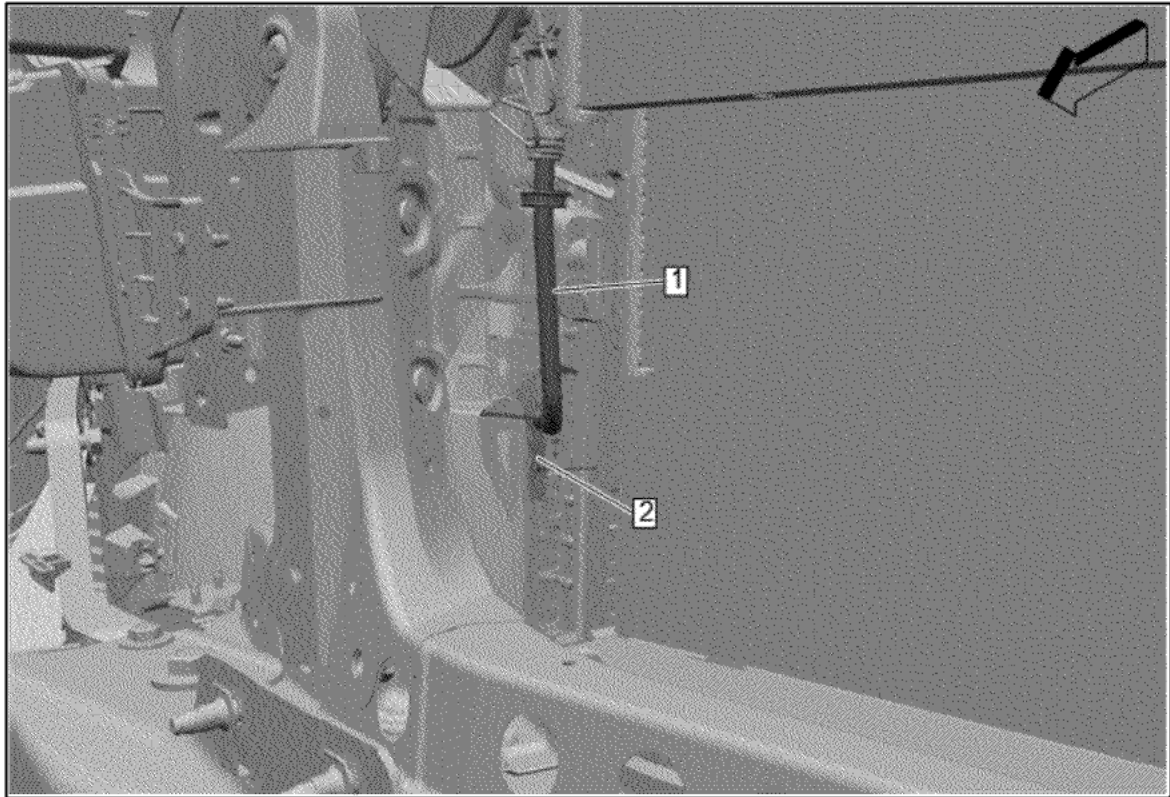

164. Transmission Fluid Cooler Inlet and Outlet Pipe (1) @ Transmission Fluid Auxiliary Cooler » Install — Transmission Fluid Cooler Hose/Pipe Quick-Connect Fitting Disconnection and Connection
165. Transmission Fluid Cooler Inlet and Outlet Pipe Bolt (2) @ Radiator » Install and tighten — Fastener Specifications

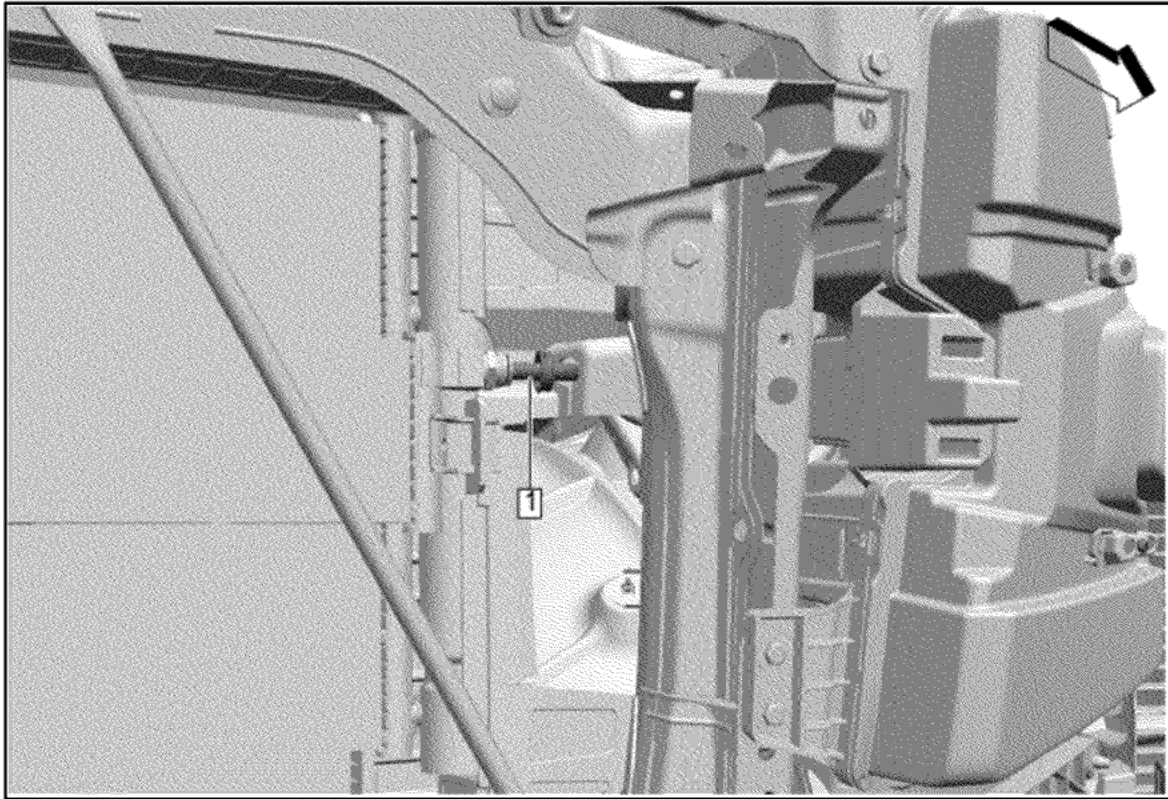

166. Transmission Fluid Cooler Inlet and Outlet Pipe (1) @ Transmission Fluid Auxiliary Cooler » Install — Transmission Fluid Cooler Hose/Pipe Quick-Connect Fitting Disconnection and Connection

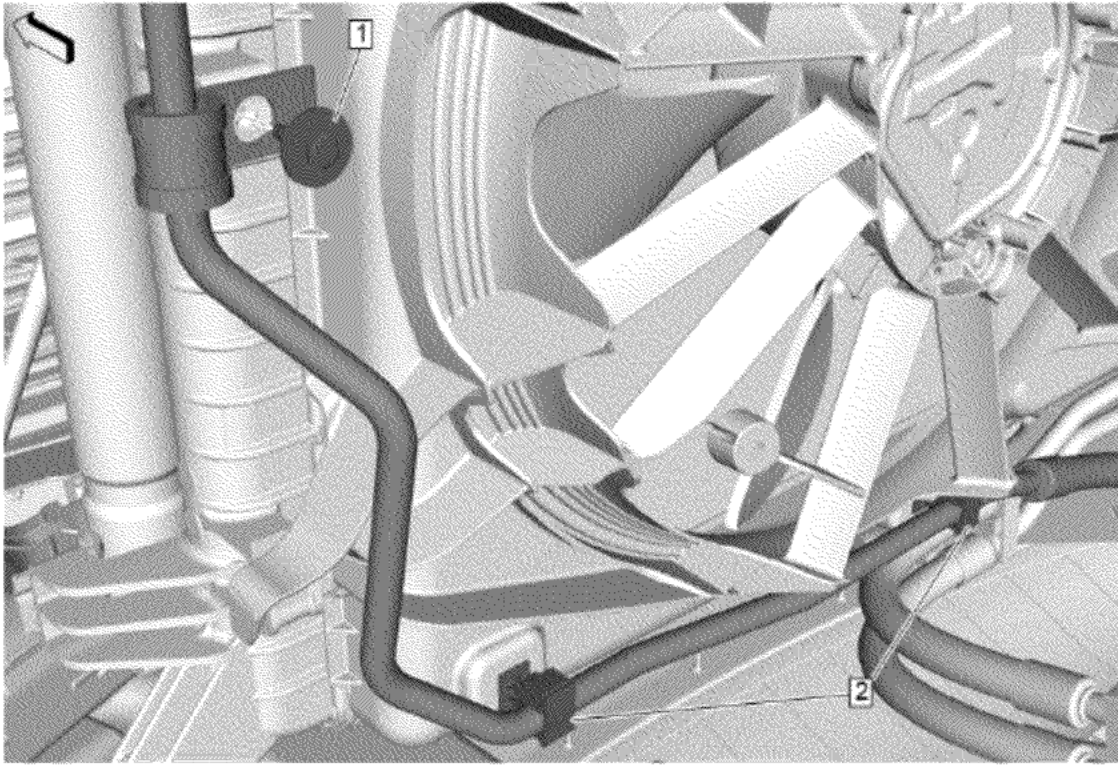

167. Transmission Fluid Cooler Pipe Clip (2) » Install [2x]

168. Transmission Fluid Cooler Pipe Bolt (1) » Install and tighten — [Fastener Specifications](#)

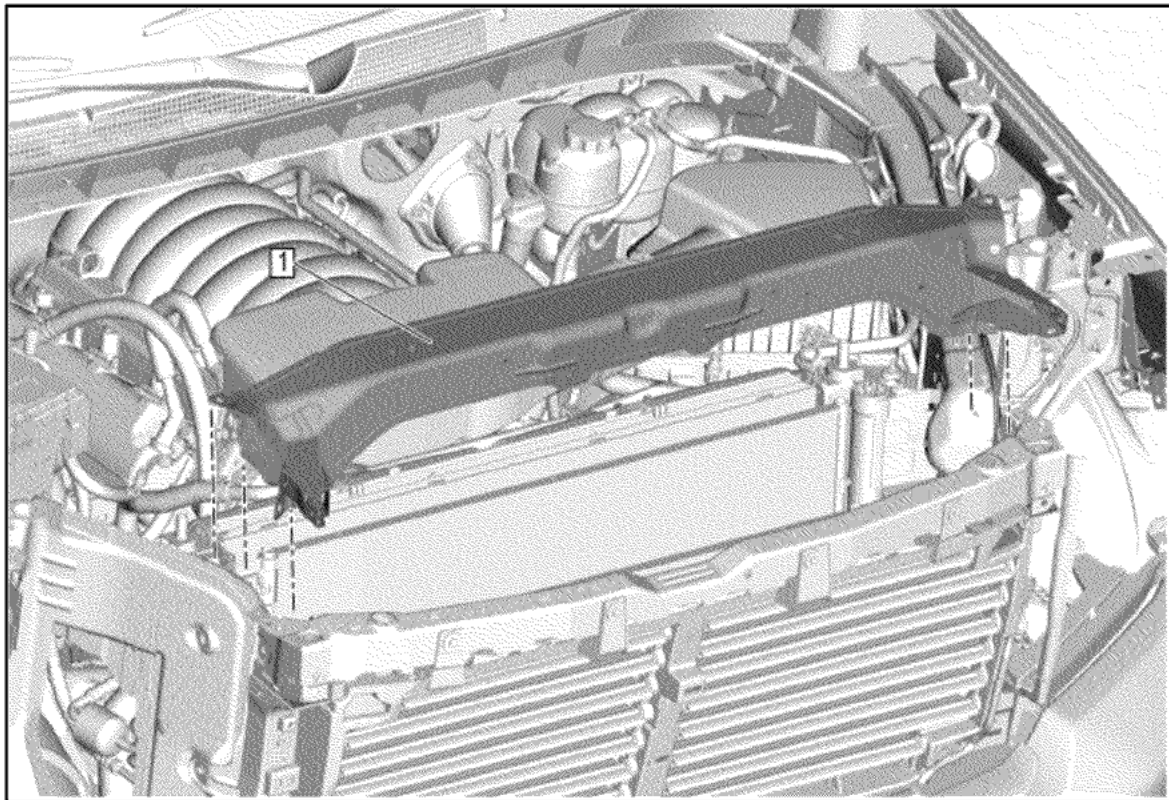

169. Front End Upper Tie Bar (1) » Install

170. Install the wiring harness.

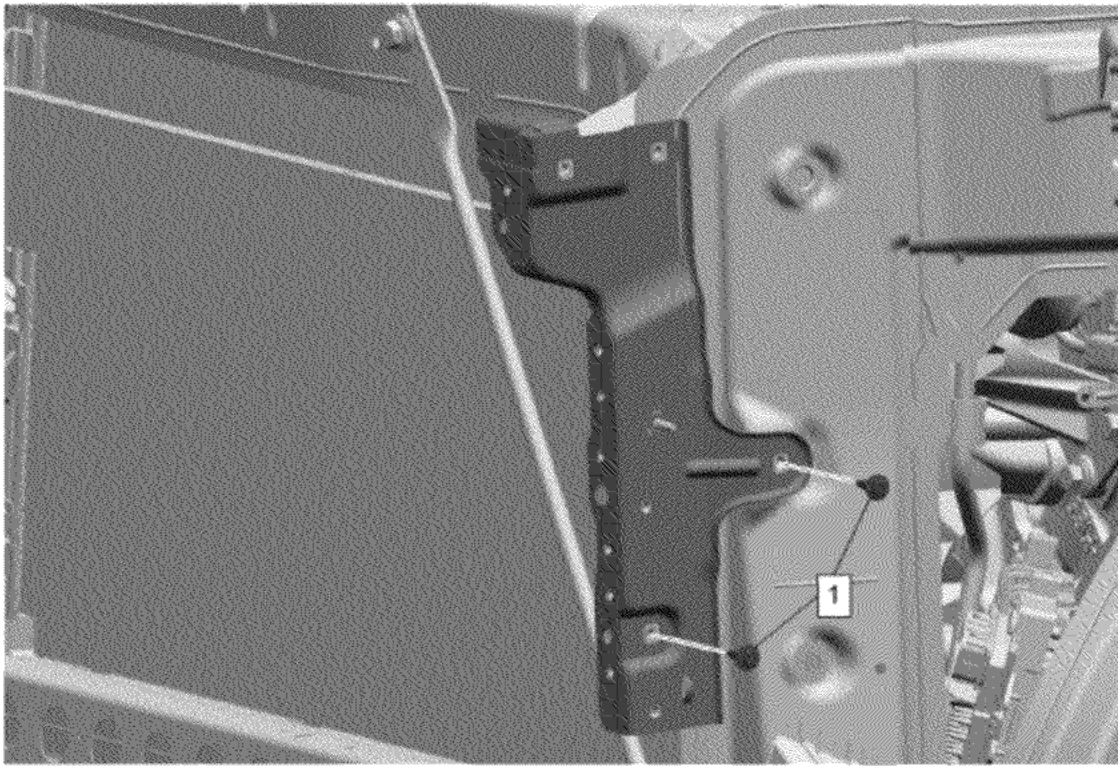

Note: Left side shown, right side similar.

171. Headlamp Bracket Bolt - Left Side and Right Side (1) » Tighten [4x] — Fastener Specifications

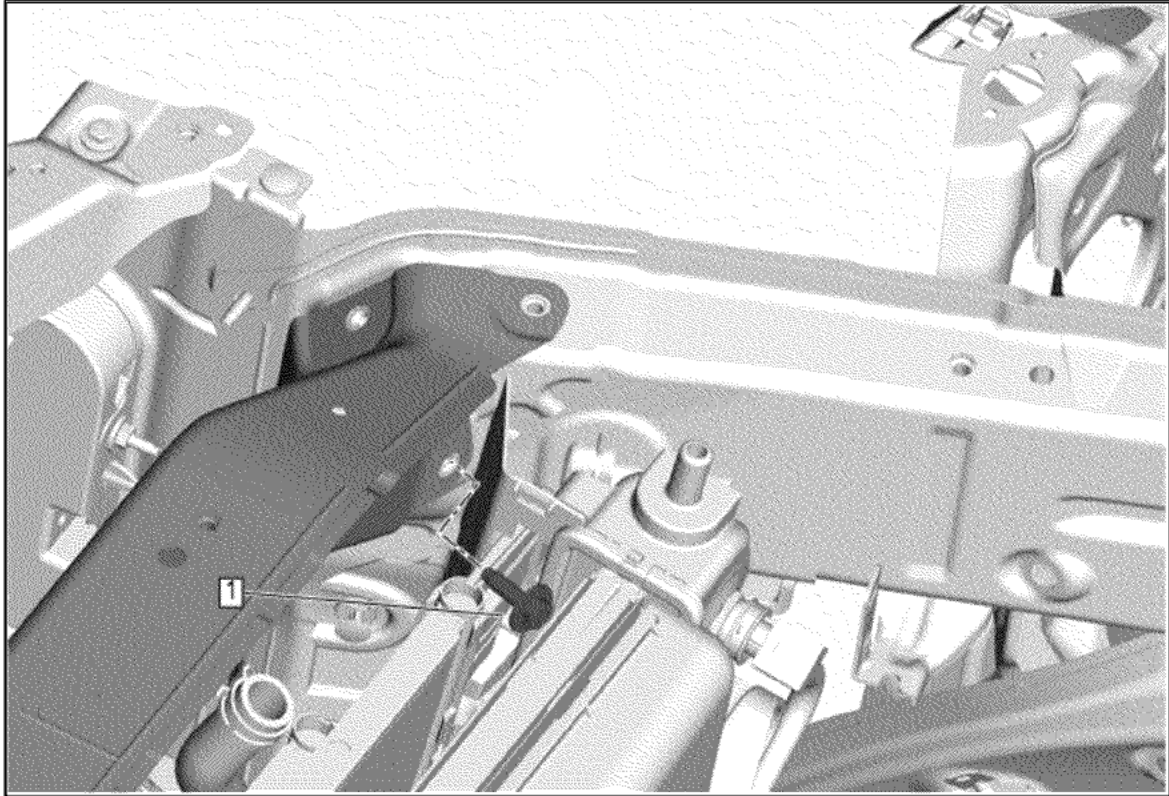

172. Front End Upper Tie Bar Bolt - Right Side (1) » Install and tighten — [Fastener Specifications](#)

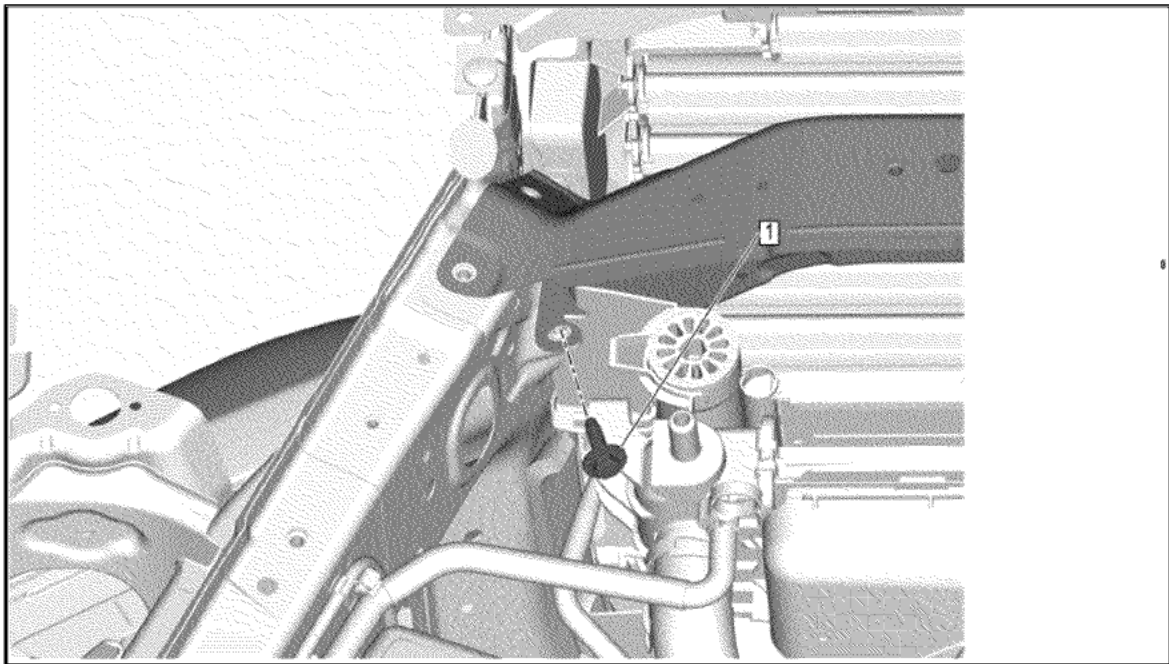

173. Front End Upper Tie Bar Bolt - Left Side (1) » Install and tighten — [Fastener Specifications](#)

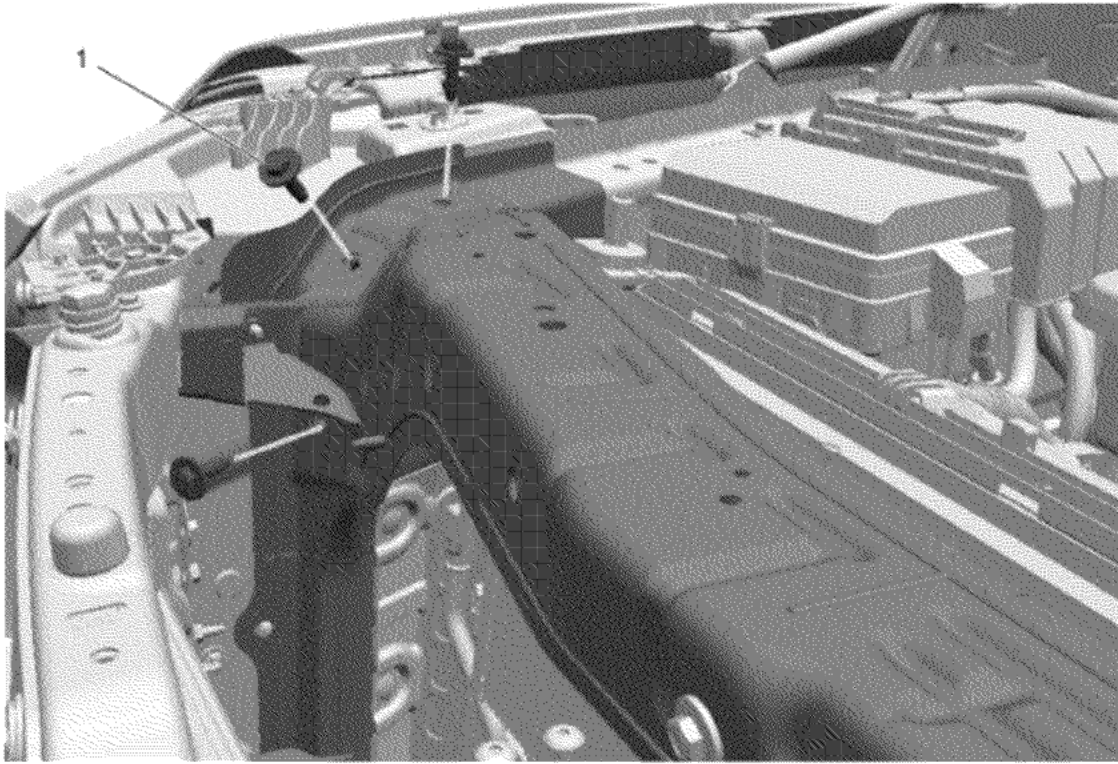

174. Front End Upper Tie Bar Bolt - Right Side (1) » Install and tighten [3x] — [Fastener Specifications](#)

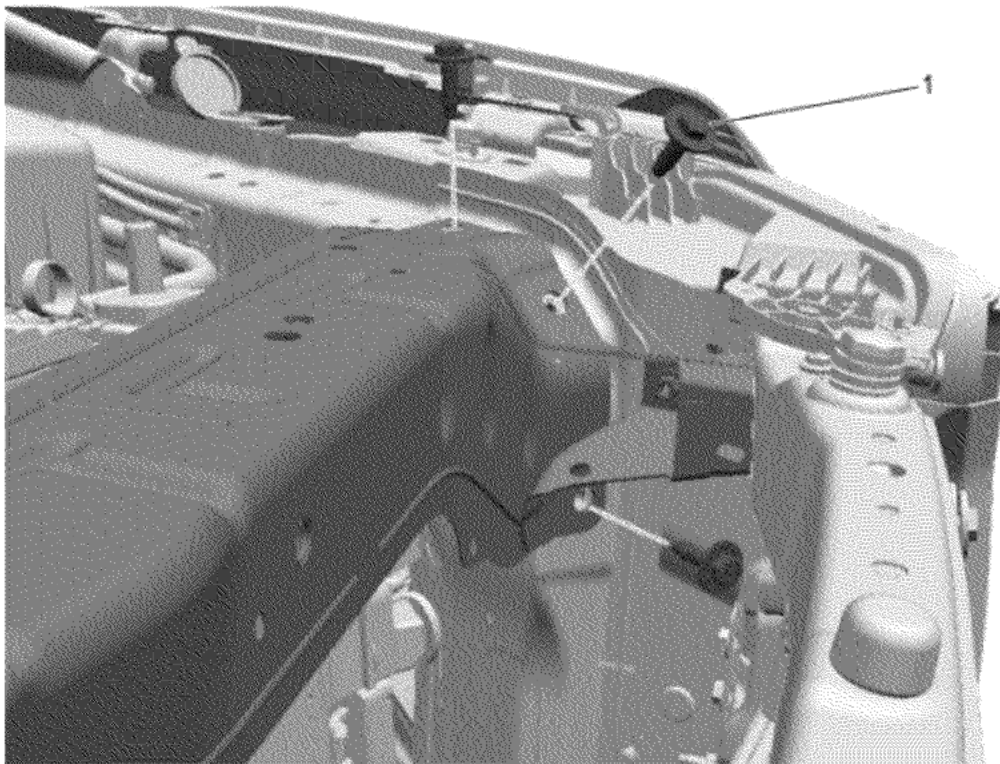

175. Front End Upper Tie Bar Bolt - Left Side (1) » Install and tighten [3x] — Fastener Specifications

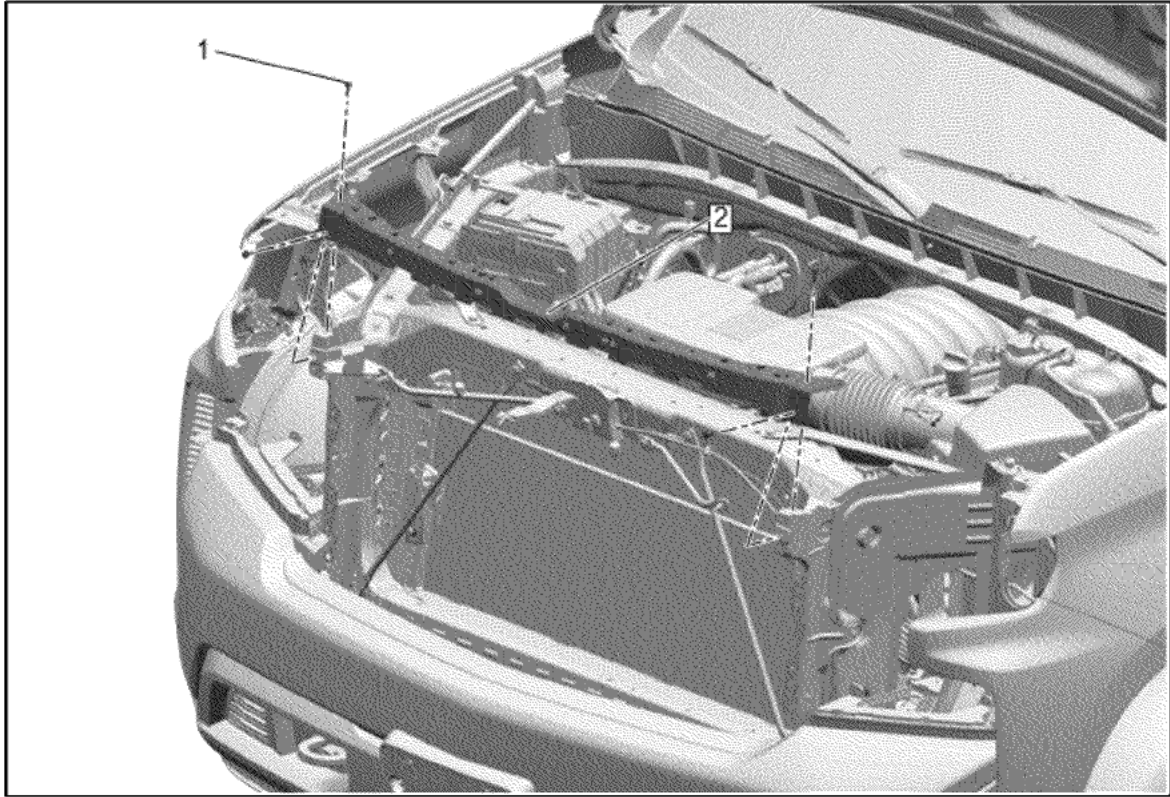

© 2025 General Motors. All rights reserved.

176. Front Grille Support Reinforcement (2) » Install

177. Front Bumper Fascia Center Support Bolt (1) » Install and tighten [4x] — Fastener Specifications

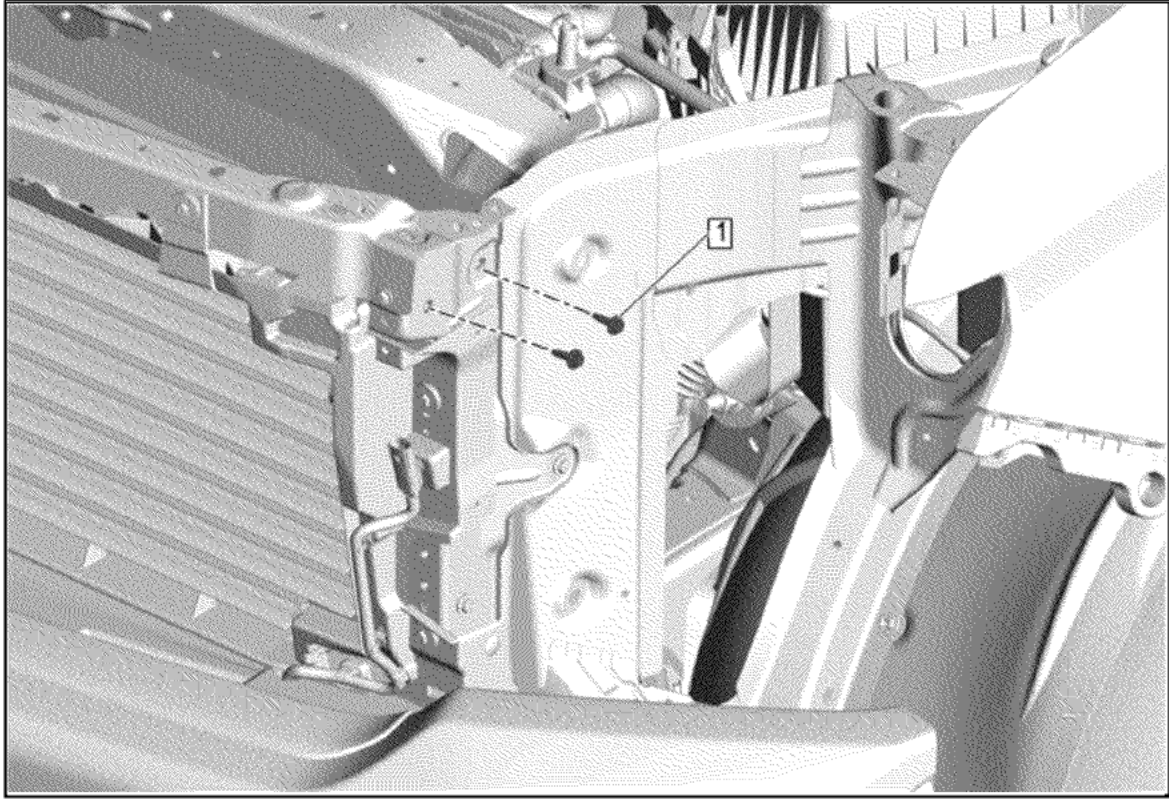

178. Front End Upper Tie Bar Bolt - Left Side and Right Side (1) @ Headlamp Bracket » Install and tighten [4x] — [Fastener Specifications](#)

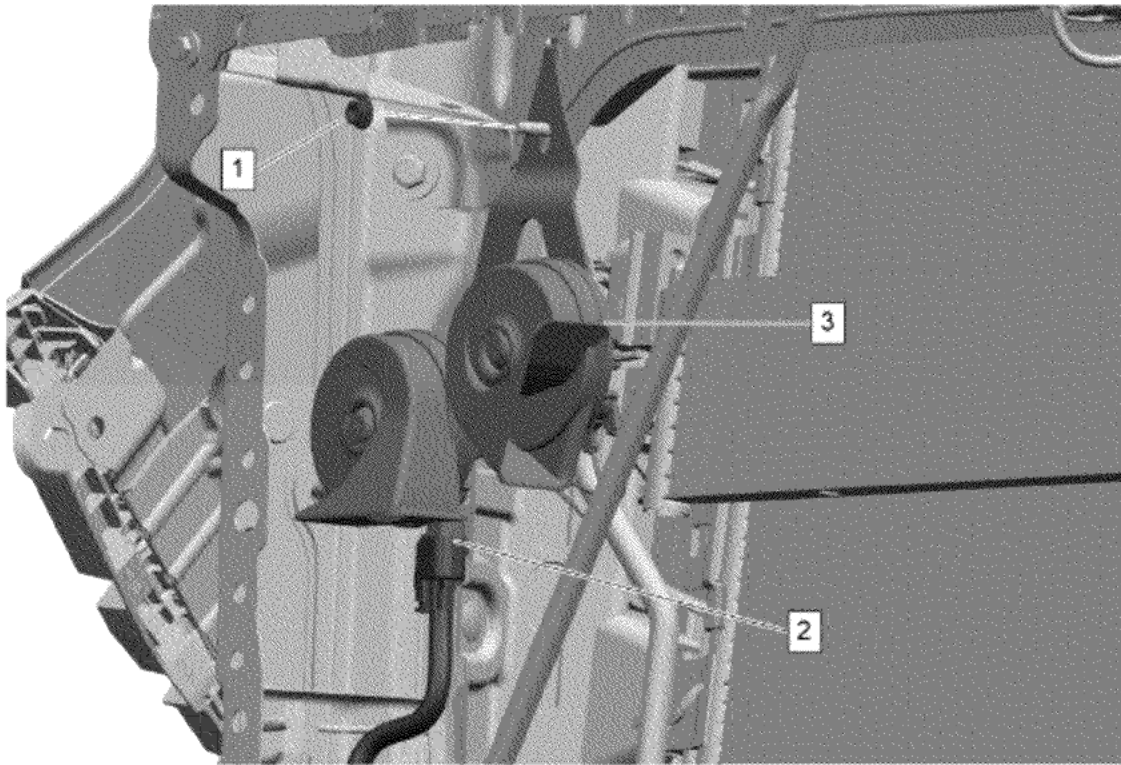

179. Electrical Connector (2) » Connect

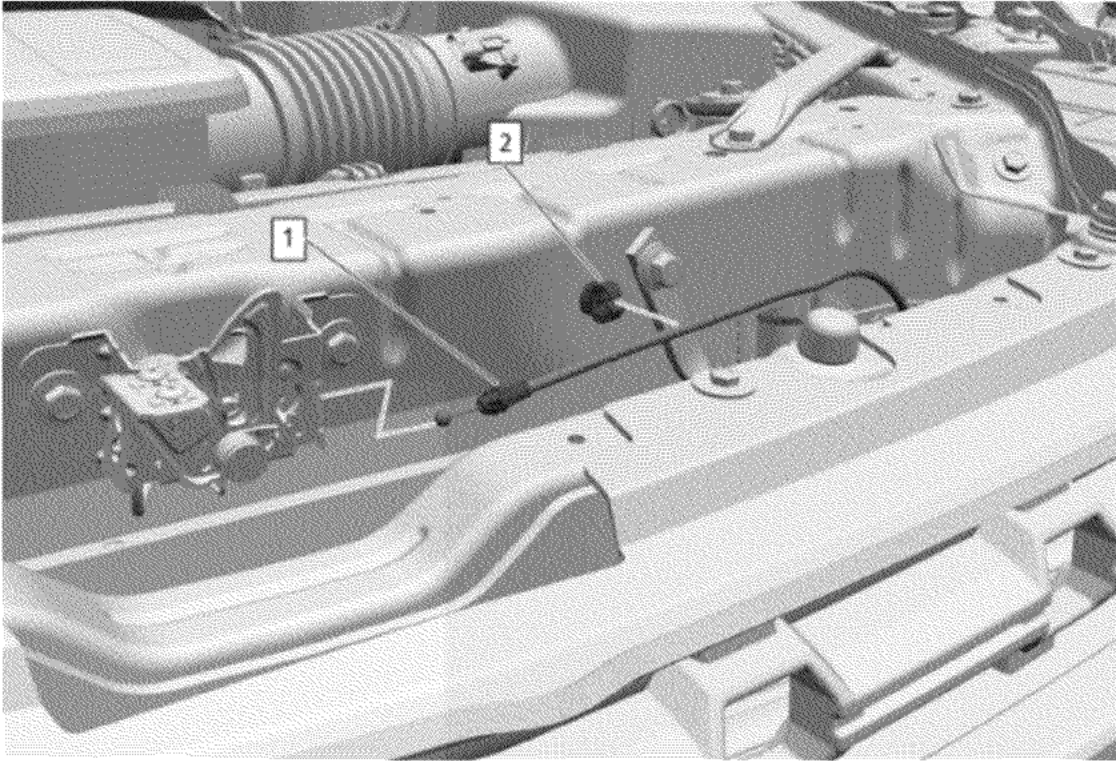

© 2025 General Motors. All rights reserved.

180. Connect the electrical connector.

181. Hood Primary Latch Release Cable (1) » Install @ Hood Primary Latch

182. Install the hood primary latch release cable (1) to the upper tie bar retainer (2).

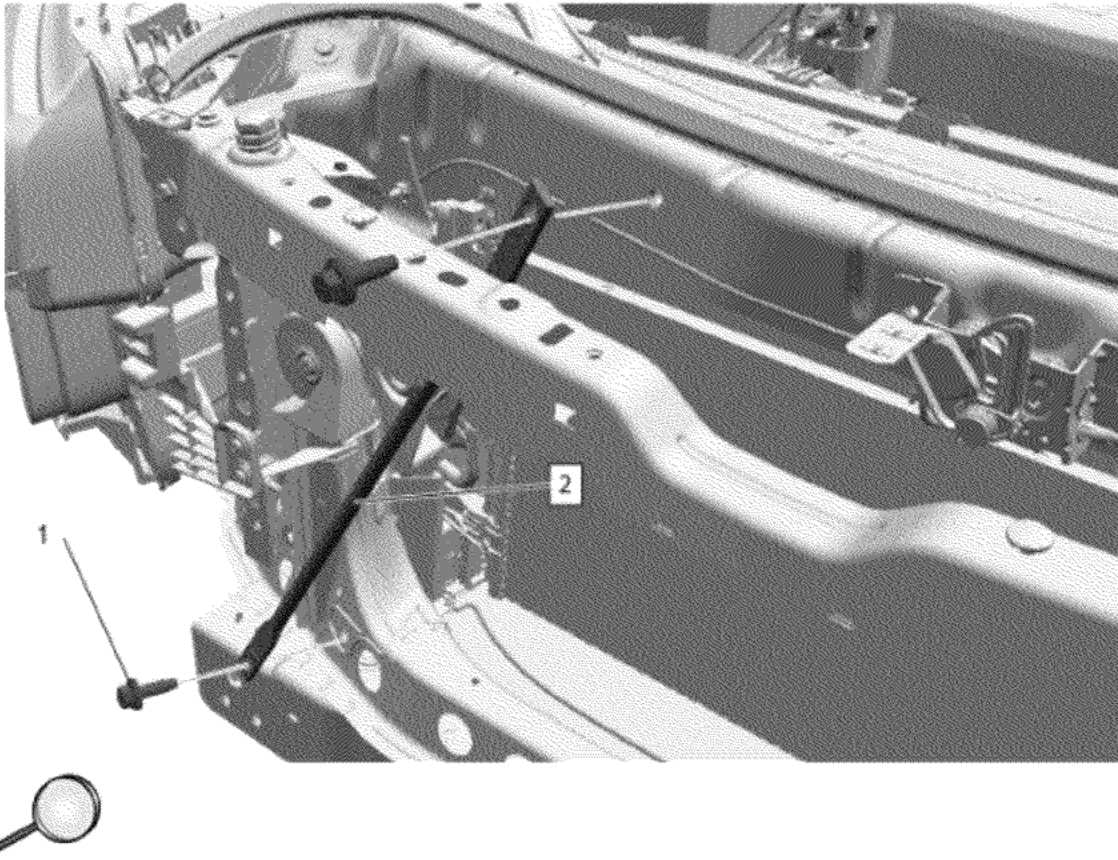

183. Front End Sheet Metal Diagonal Brace - Left Side and Right Side (2) @ Radiator Support » Install [2x]
184. If NEW threaded components are being installed, loosen the adhesive using a metal pick or similar tool before proceeding. If threaded components are reused, prepare the threaded components using the following steps:
- 184.1. Remove any loose cured adhesive from the external threads of the components using a lint free cloth.
 - 184.2. Thread the cleaned components into the internal mating threads and remove to loosen trapped cured adhesive.
 - 184.3. Apply thread locking adhesive to the external threads of the components. **Adhesives, Fluids, Lubricants, and Sealers**
 - 184.4. Ensure there are no gaps in the thread locking adhesive once applied to the component.
185. Front End Sheet Metal Diagonal Brace Bolt - Left Side and Right Side (1) » Install and tighten [4x] — Fastener Specifications

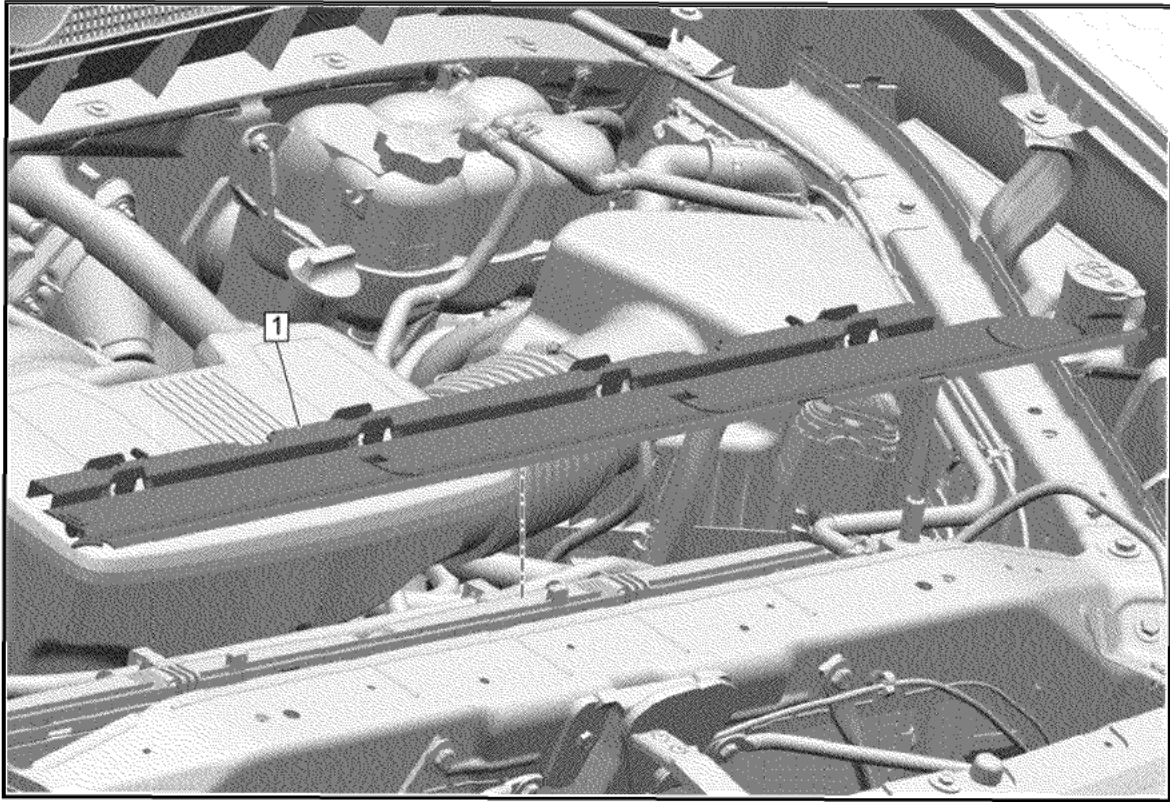

- 186. Radiator Air Upper Baffle (1) @ Radiator Air Side Baffle» Install
- 187. Radiator Air Upper Baffle (1) @ Radiator » Install

© 2025 General Motors. All rights reserved.

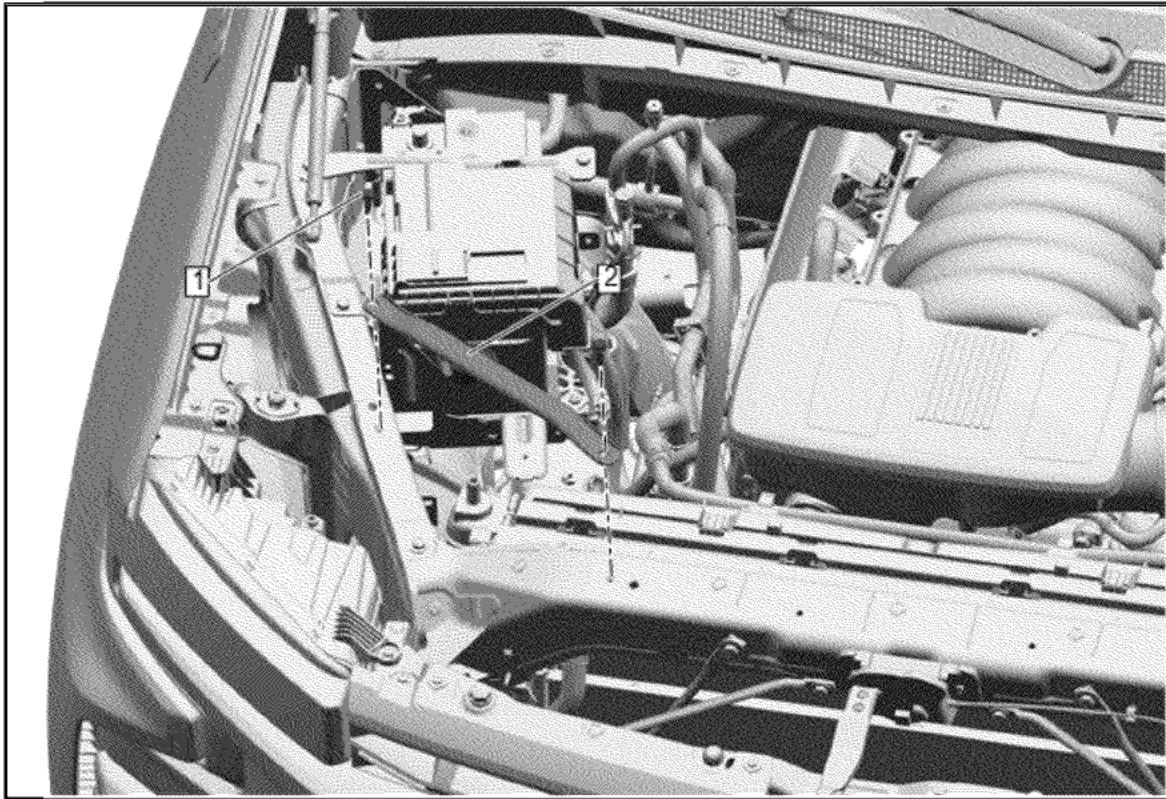

188. Front End Sheet Metal Cross Brace Bracket - Left Side and Right Side (2) » Install [2x]

189. If NEW threaded components are being installed, loosen the adhesive using a metal pick or similar tool before proceeding. If threaded components are reused, prepare the threaded components using the following steps:

189.1. Remove any loose cured adhesive from the external threads of the components using a lint free cloth.

189.2. Thread the cleaned components into the internal mating threads and remove to loosen trapped cured adhesive.

189.3. Apply thread locking adhesive to the external threads of the components. Adhesives, Fluids, Lubricants, and Sealers

189.4. Ensure there are no gaps in the thread locking adhesive once applied to the component.

190. Front End Sheet Metal Cross Brace Bracket Bolt - Left Side and Right Side (1) » Install and tighten [4x] — Fastener Specifications

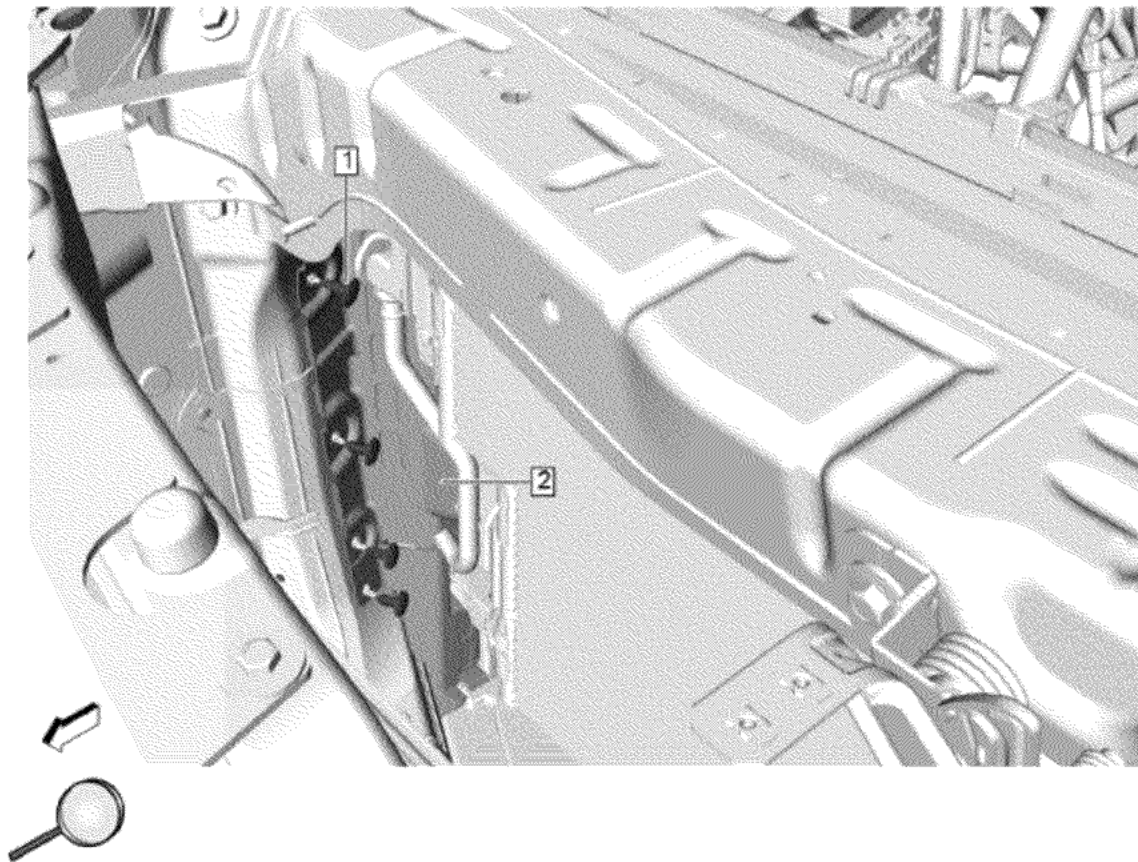

- Note:** Some components not shown for graphic clarity.
- 191. Radiator Air Side Baffle - Right Side (2) » Install
 - 192. Radiator Air Side Baffle Retainer (1) » Install [4x]

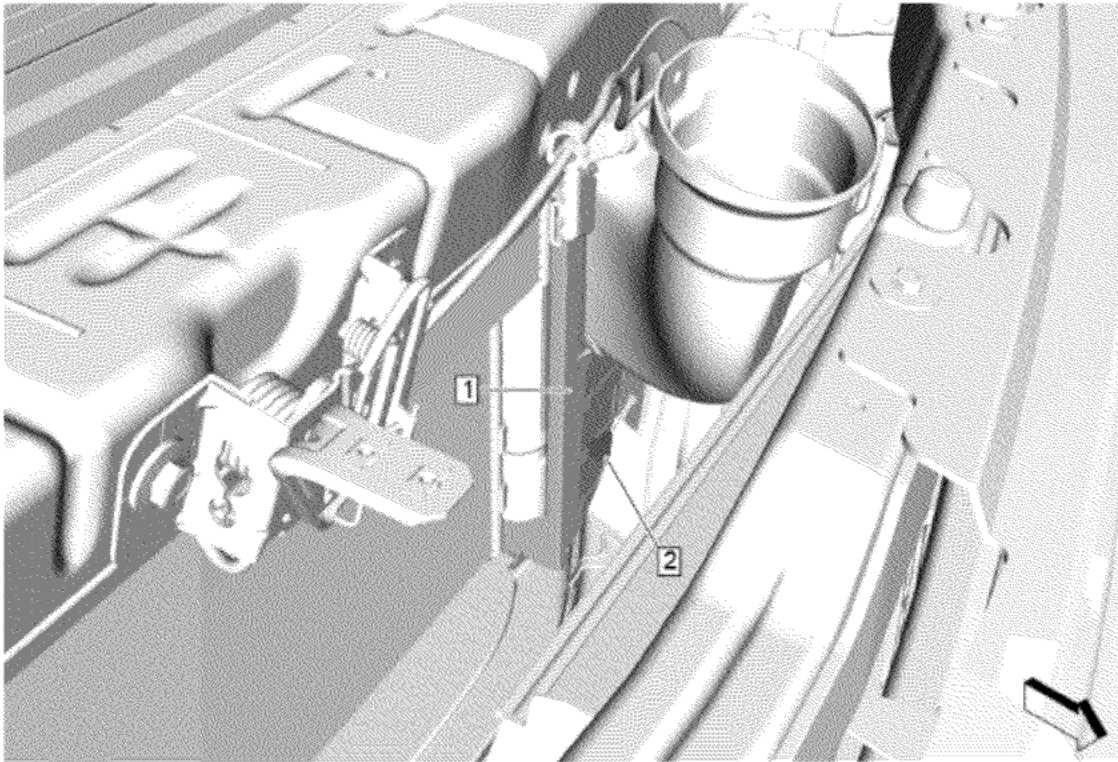

193. Radiator Air Side Baffle - Left Side (1) » Install

194. Radiator Air Side Baffle Retainer (2) » Install

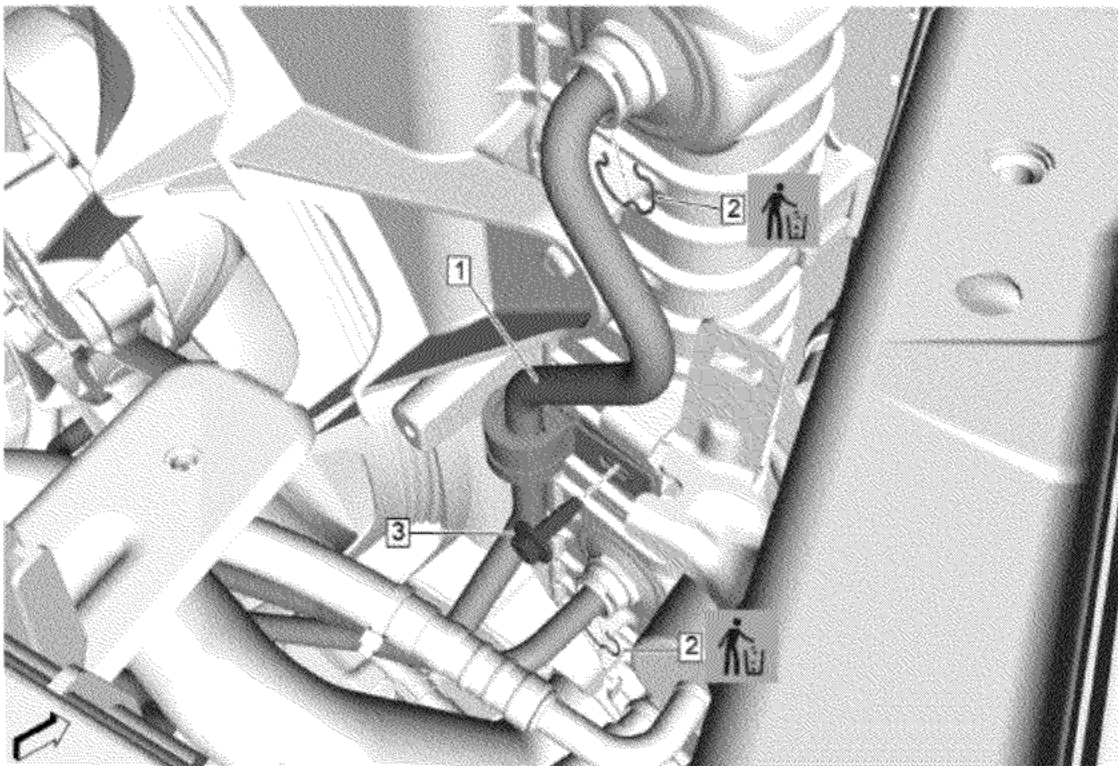

195. Engine Oil Cooler Hose (1) @ Engine Radiator » Install [2x]
196. Engine Oil Cooler Pipe Bracket Bolt (3) » Install and tighten — [Fastener Specifications](#)
197. Engine Oil Cooler Retainer (2) » Install NEW [2x]

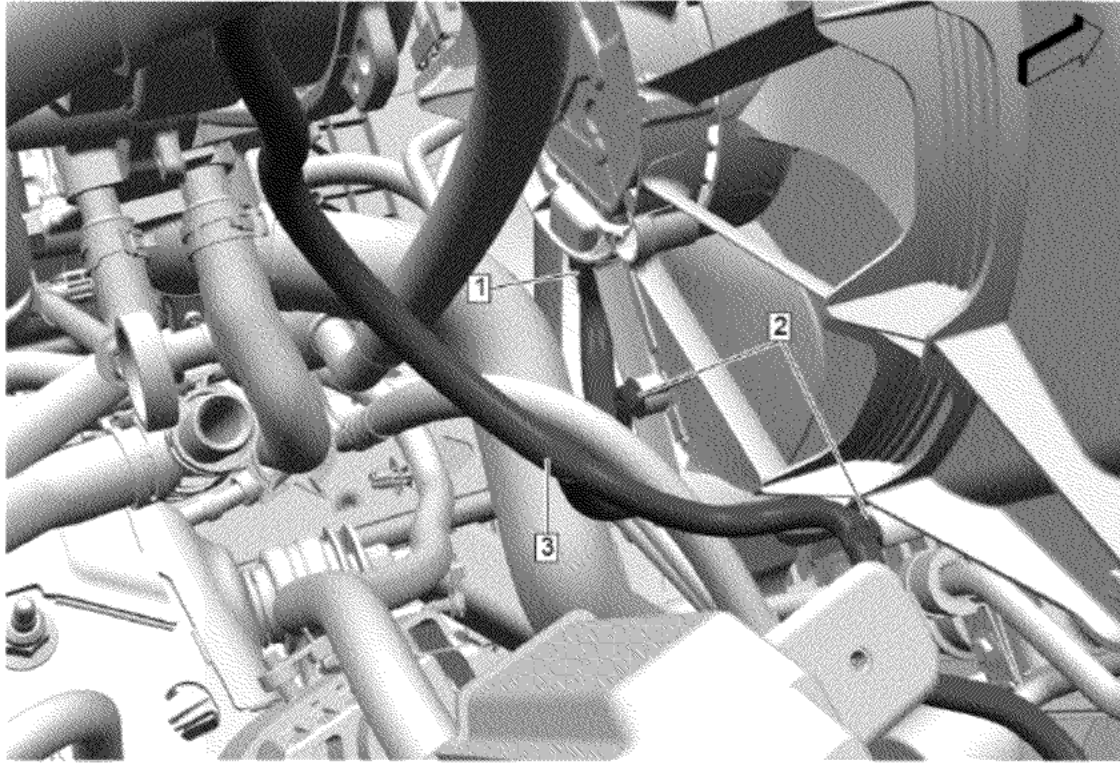

198. Position the wiring harness. (3)
199. Electrical Connector (1) » Connect
200. Wiring Harness Retainer (2) » Install [2x]

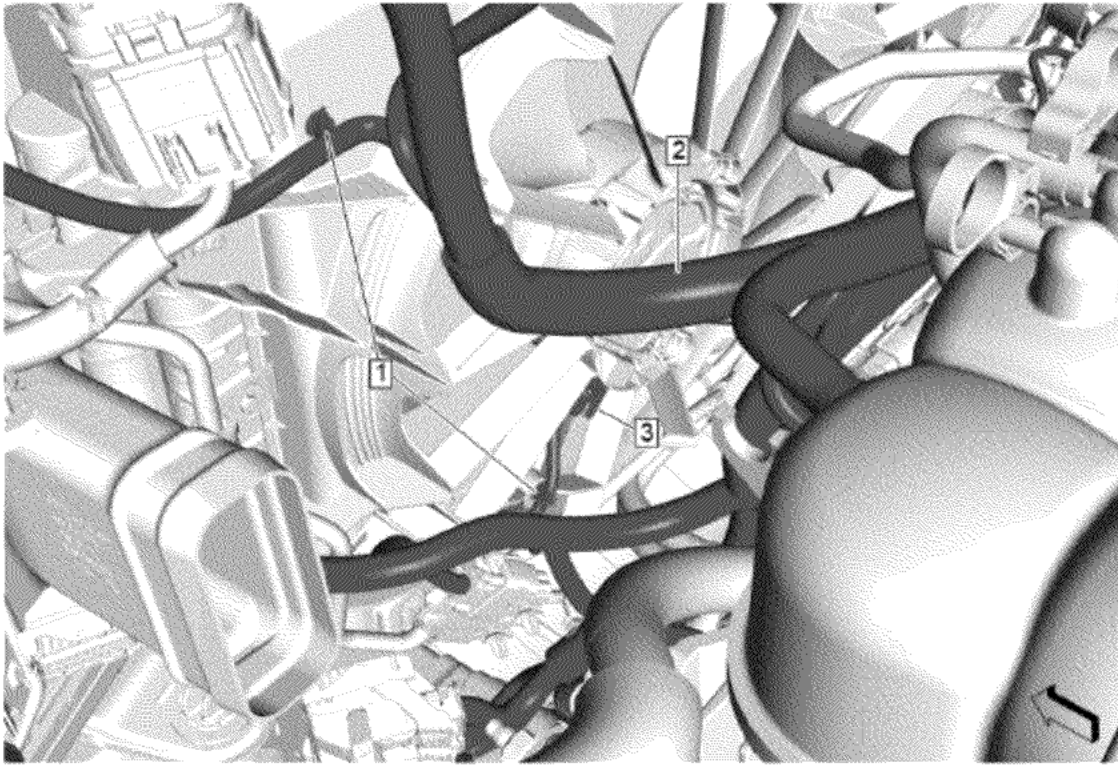

- 201. Position the wiring harness. (2)
- 202. Electrical Connector (3) » Connect
- 203. Wiring Harness Retainer (1) » Install [2x]

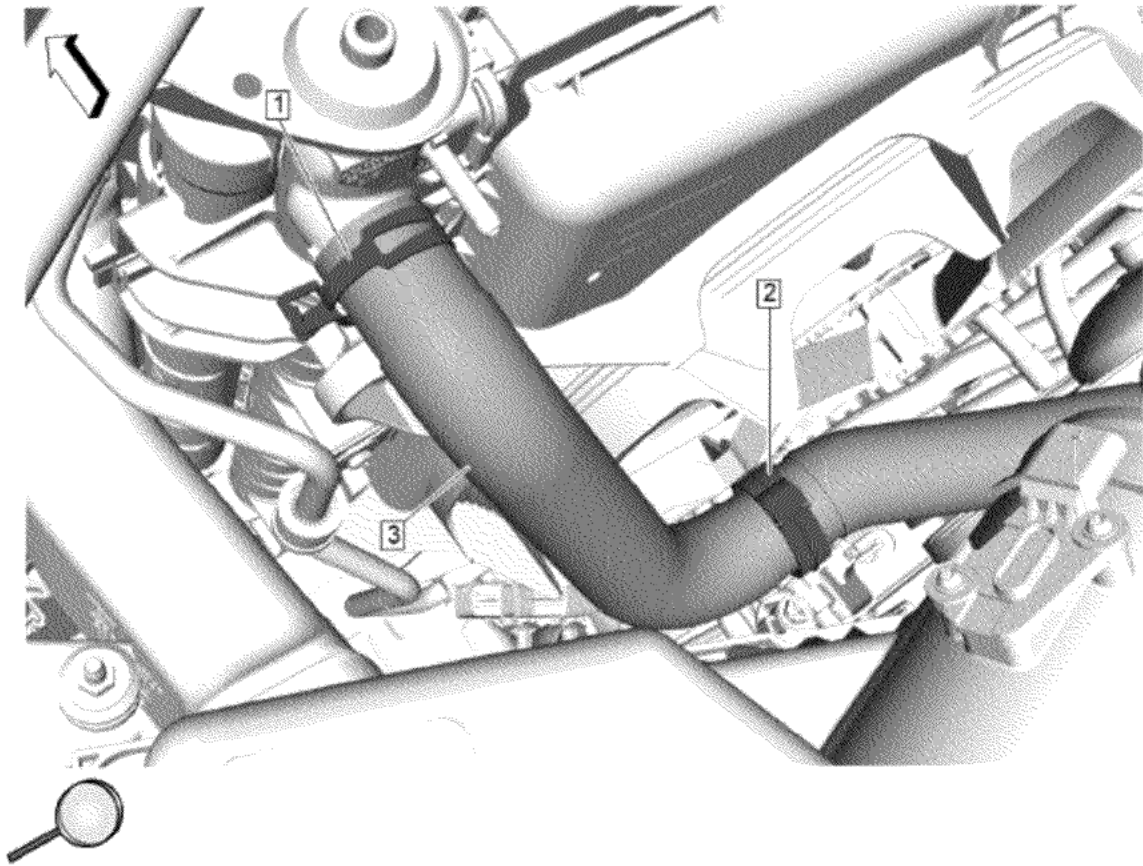

204. Radiator Inlet Hose (3) @ Engine Radiator » Install

205. Radiator Inlet Hose Clamp (1) » Engage — [Hose Clamp Replacement Guidelines - Spring Type](#)

206. Radiator Inlet Hose Clip (2) » Install

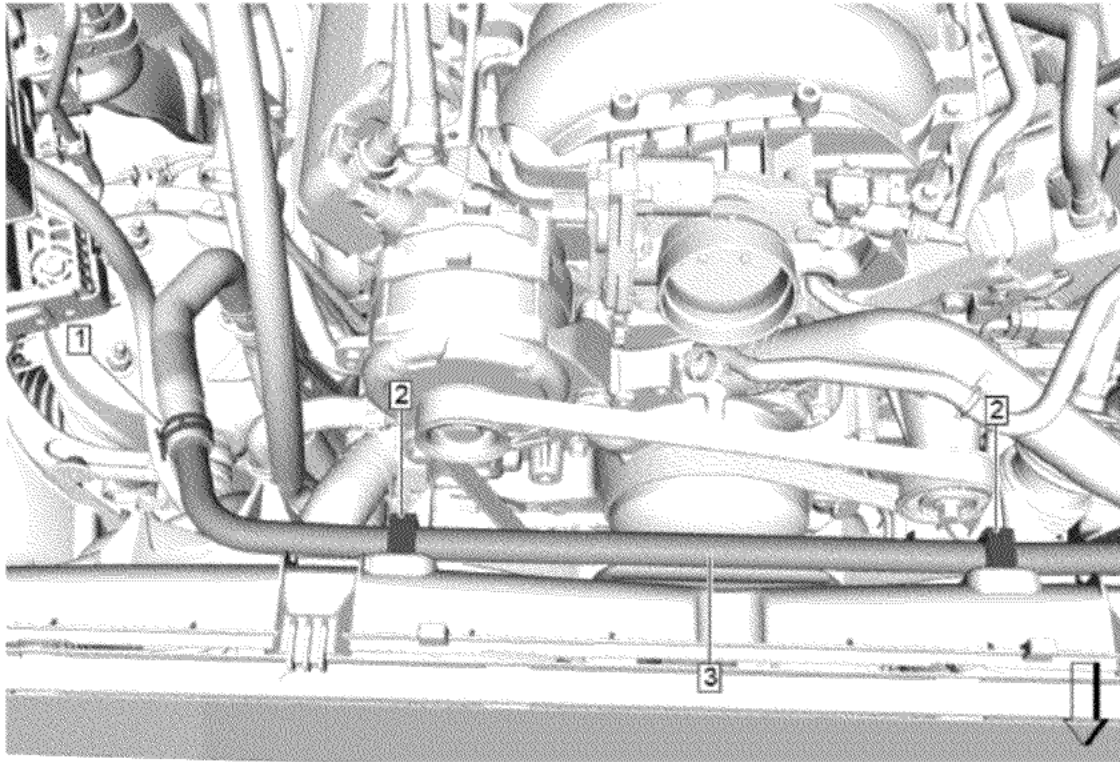

207. Radiator Surge Tank Outlet Hose (3) » Install

208. Radiator Surge Tank Outlet Hose Clip (2) » Install [2x]

209. Heater Outlet Hose Clamp (4) » Engage — [Hose Clamp Replacement Guidelines - Spring Type](#)

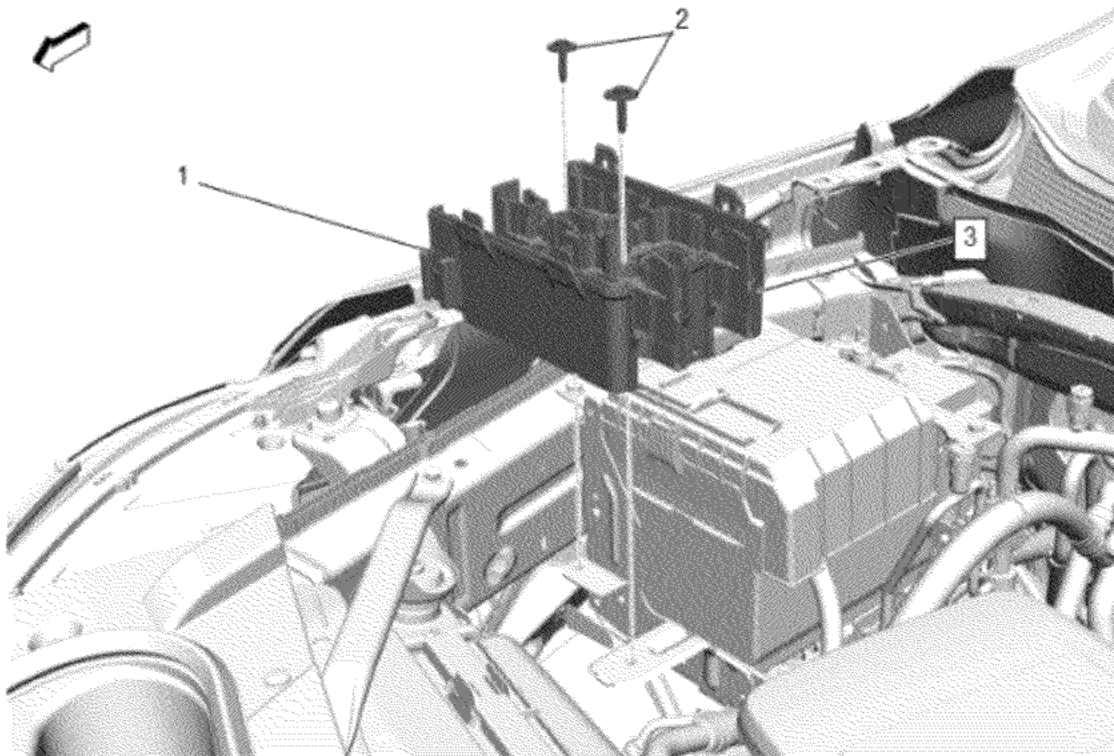

210. Engine Wiring Harness Fuse Block Bracket (3) » Install

211. Retaining Tab (1) » Engage

212. Engine Wiring Harness Fuse Block Bracket Bolt (2) » Tighten [2x] — [Fastener Specifications](#)

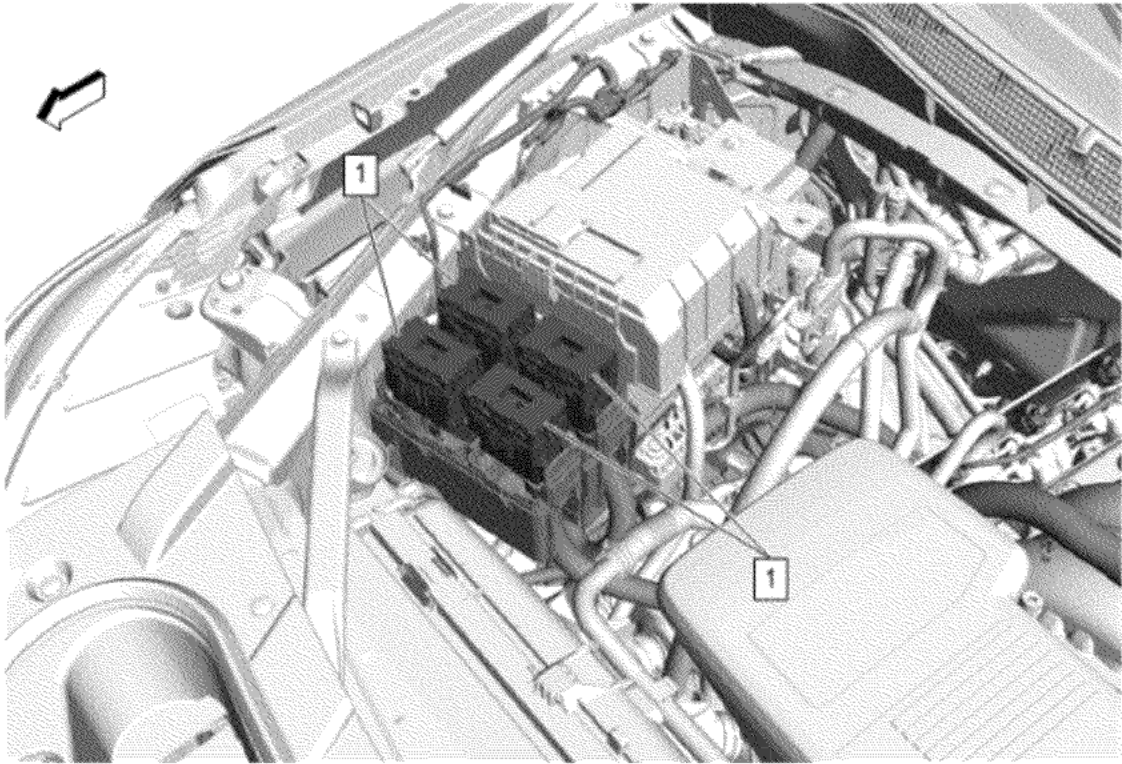

213. Electrical Connector (1) » Install [4x]

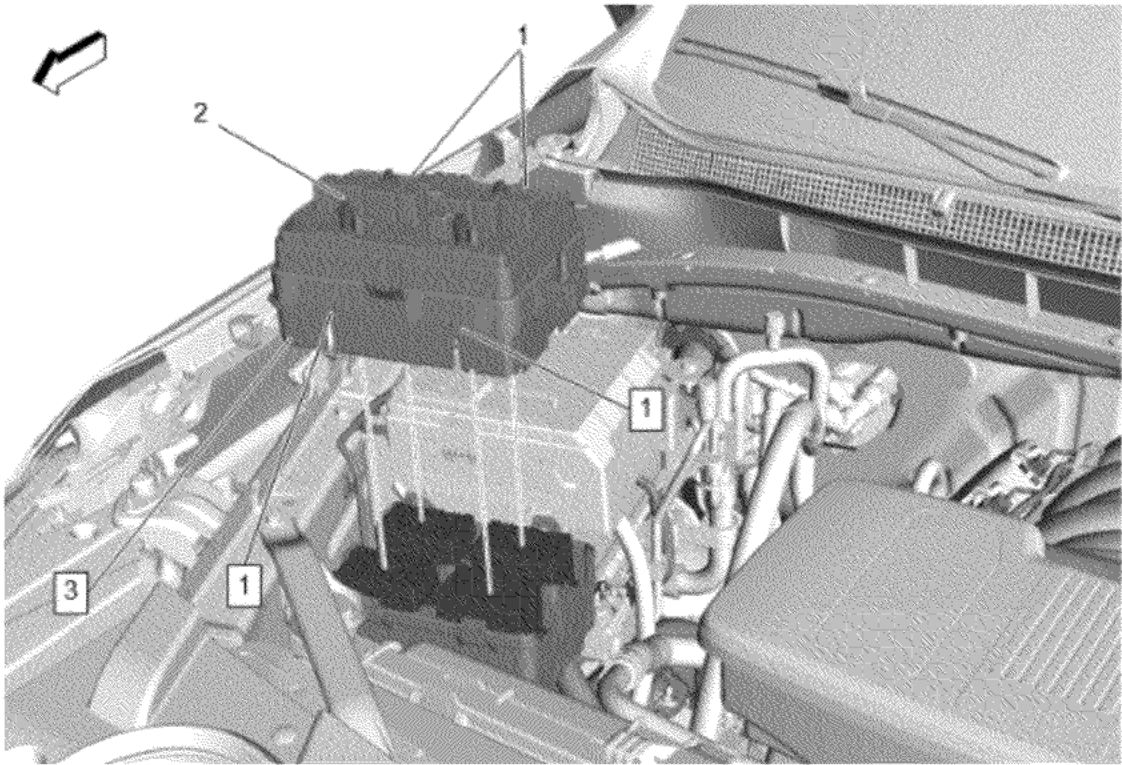

214. Engine Wiring Harness Junction Block (3) » Install

215. Retaining Tab (1) » Engage [4x]

216. Engine Wiring Harness Junction Block Bolt (2) » Tighten [4x] — [Fastener Specifications](#)

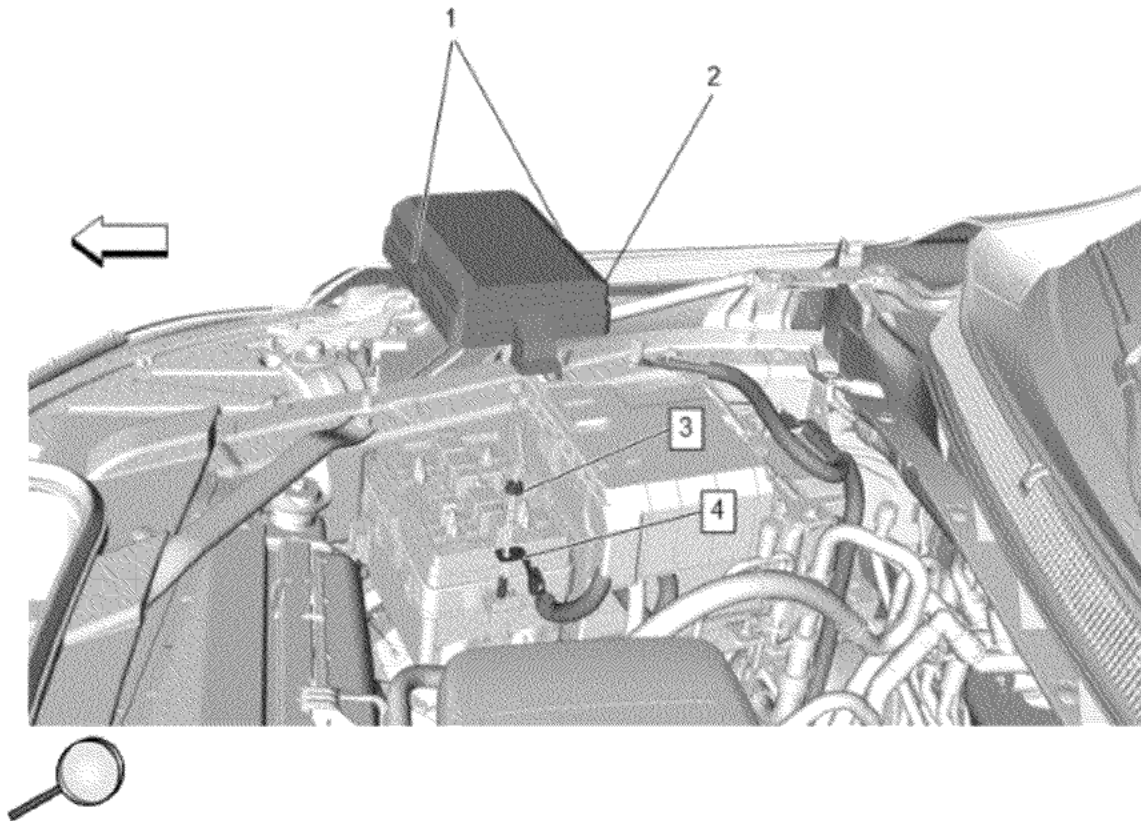

© 2025 General Motors. All rights reserved.

217. Starter Solenoid Cable (4) » Install

218. Battery Positive Cable Nut (3) » Install and tighten — [Fastener Specifications](#)

219. Engine Wiring Harness Junction Block Cover (2) » Install

220. Retaining Tab (1) » Engage [2x]

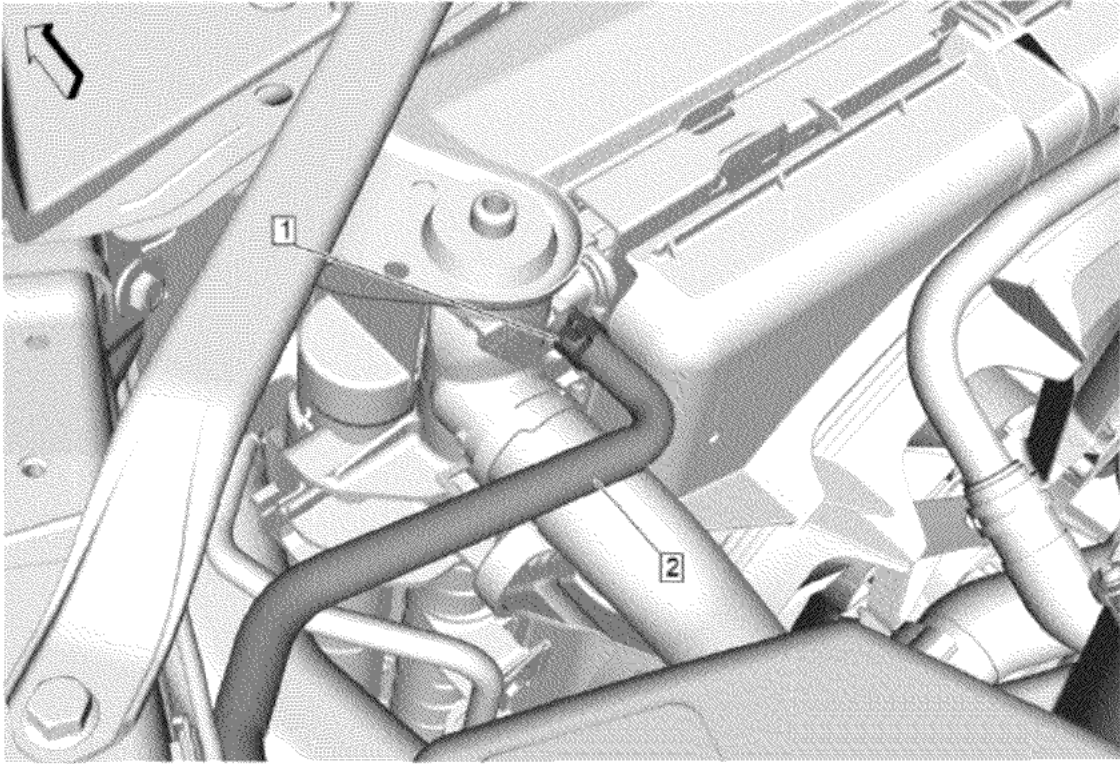

221. Radiator Surge Tank Inlet Hose (2) @ Engine Radiator » Install

222. Radiator Surge Tank Inlet Hose Clamp (1) » Engage — [Hose Clamp Replacement Guidelines - Spring Type](#)

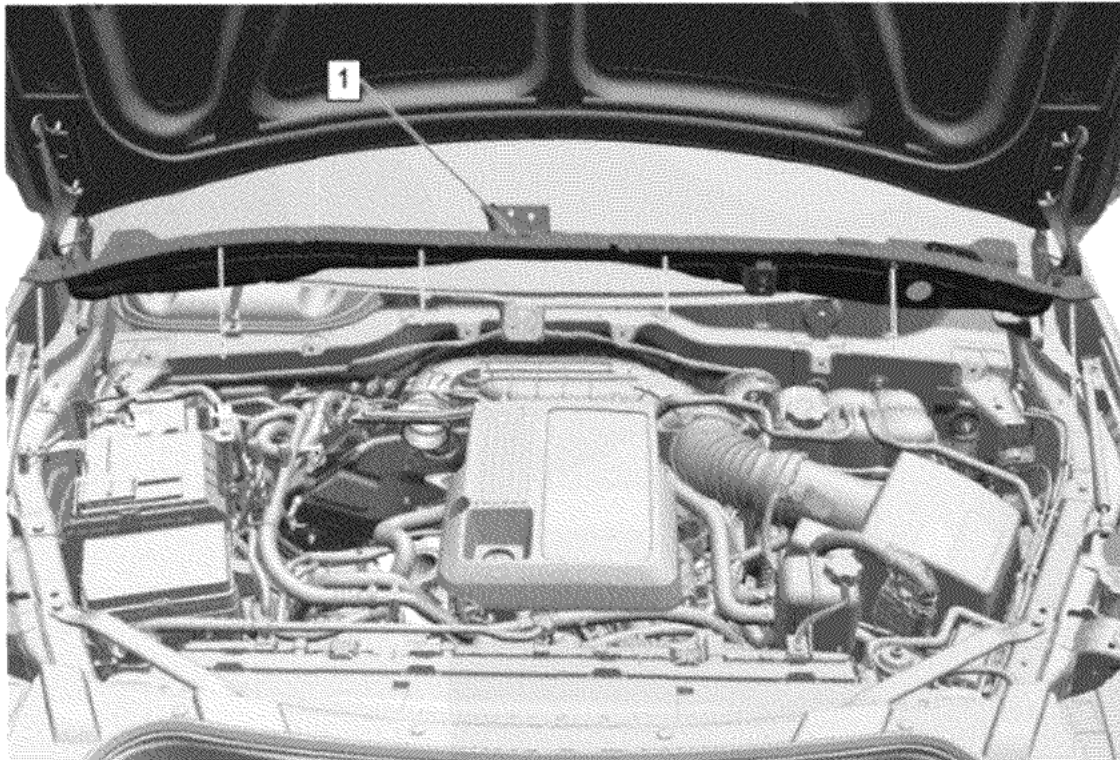

223. Plenum Front Panel Outer Reinforcement (1) » Install — Plenum Front Panel Outer Reinforcement Removal and Installation

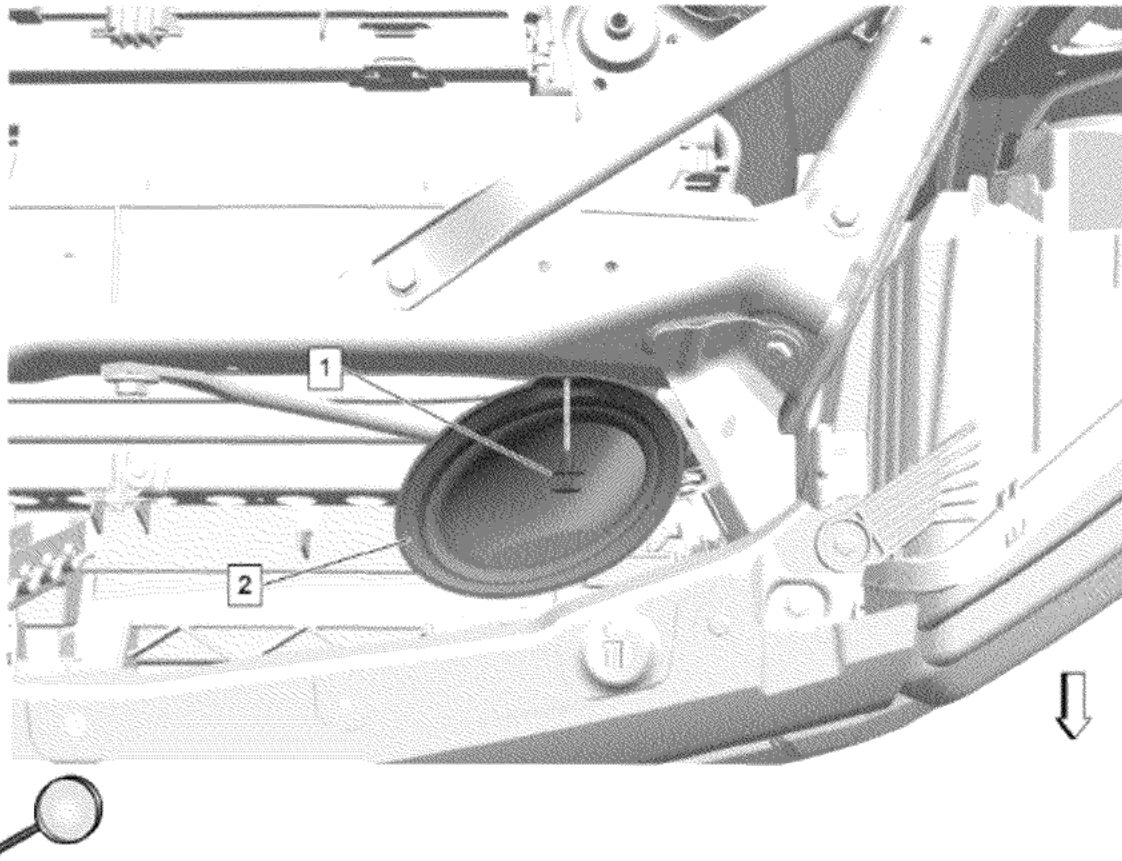

© 2025 General Motors. All rights reserved.

224. Intake Air Duct (2) » Install

225. Intake Air Duct Retainer (1) » Install

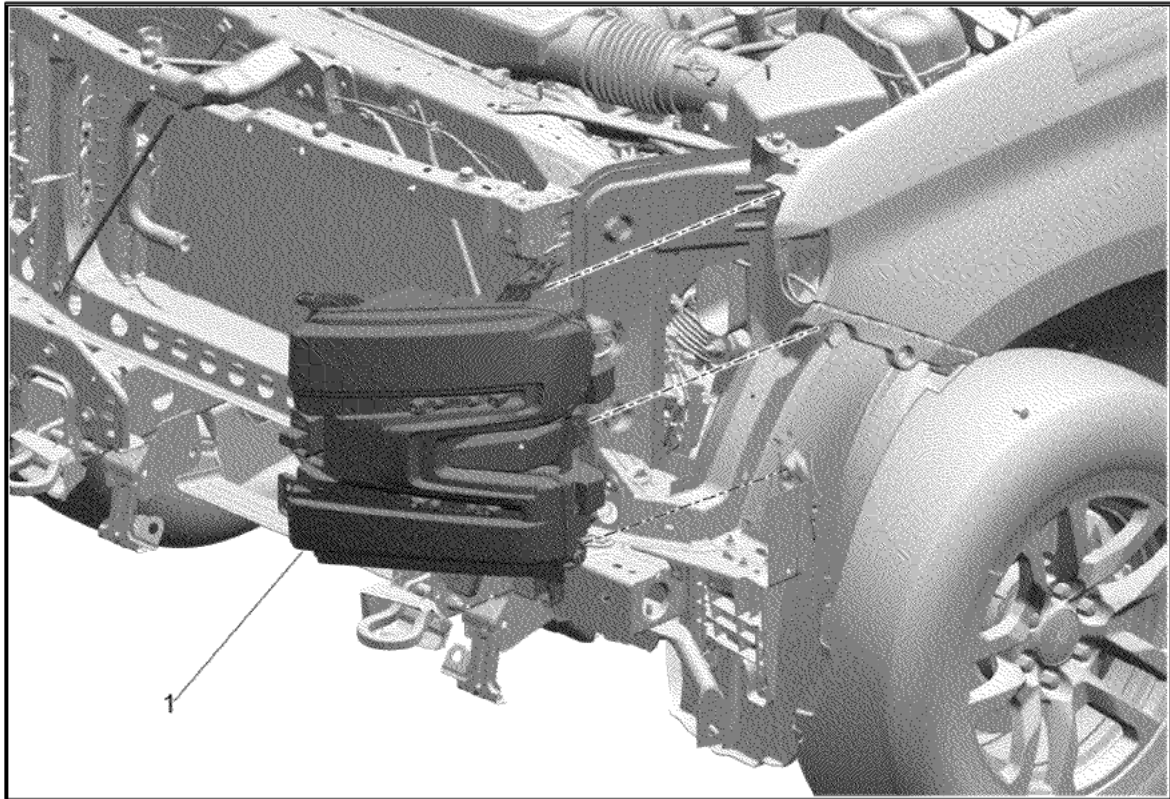

- 226. Headlamp - Left Side and Right Side (1) » Install [2x]
- 227. Connect the electrical connectors.

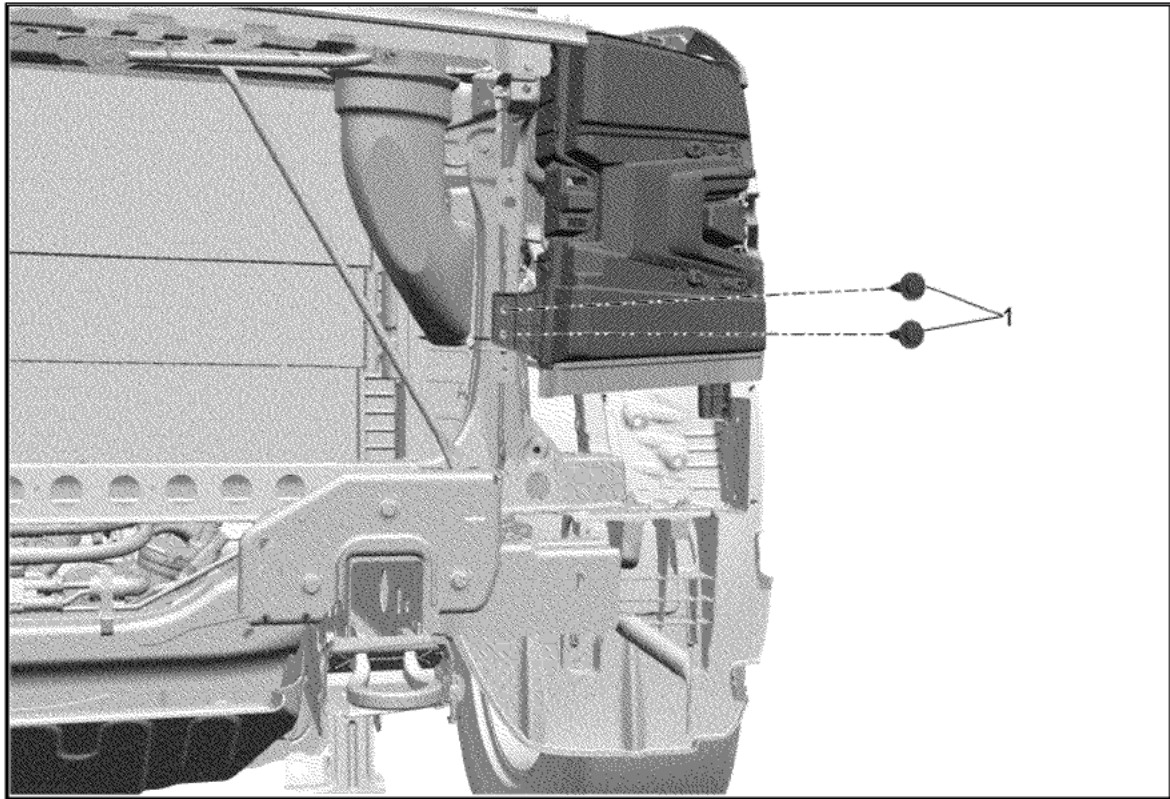

© 2025 General Motors. All rights reserved.

228. Headlamp Bolt - Left Side and Right Side (1) » Install and tighten [4x] — Fastener Specifications

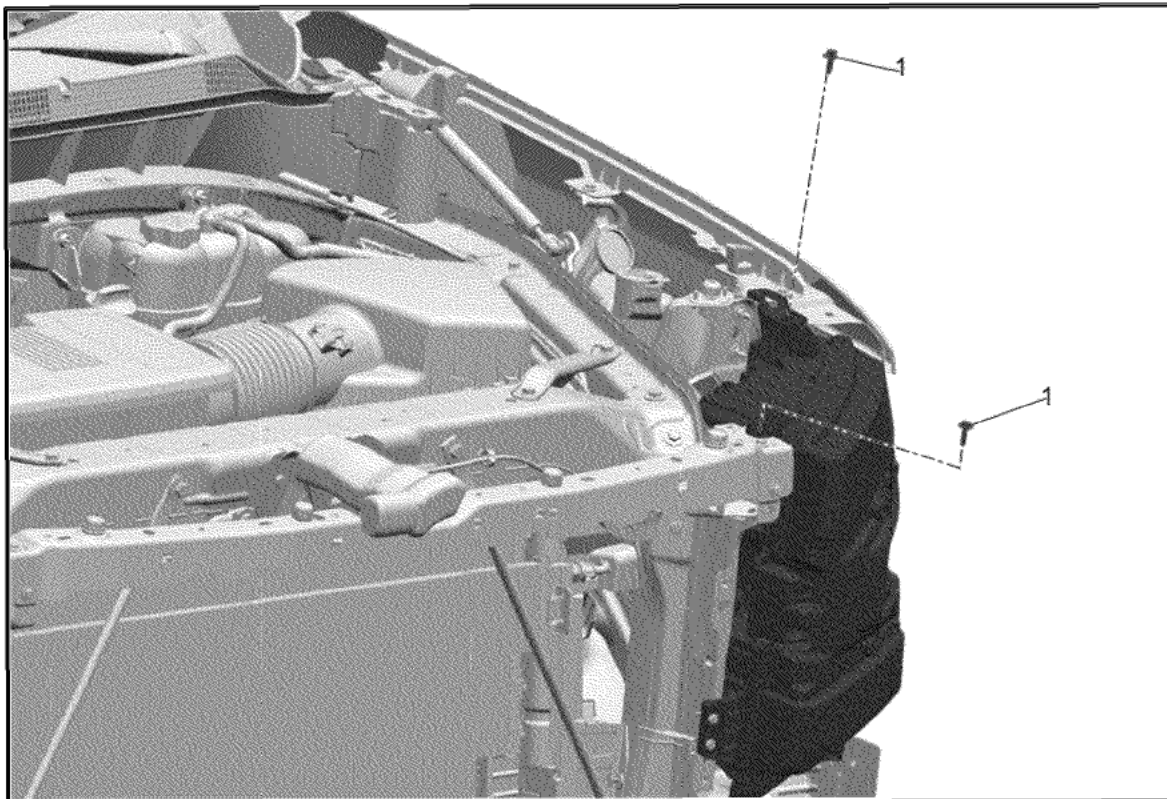

229. Headlamp Bolt - Left Side and Right Side (1) » Install and tighten [4x] — [Fastener Specifications](#)

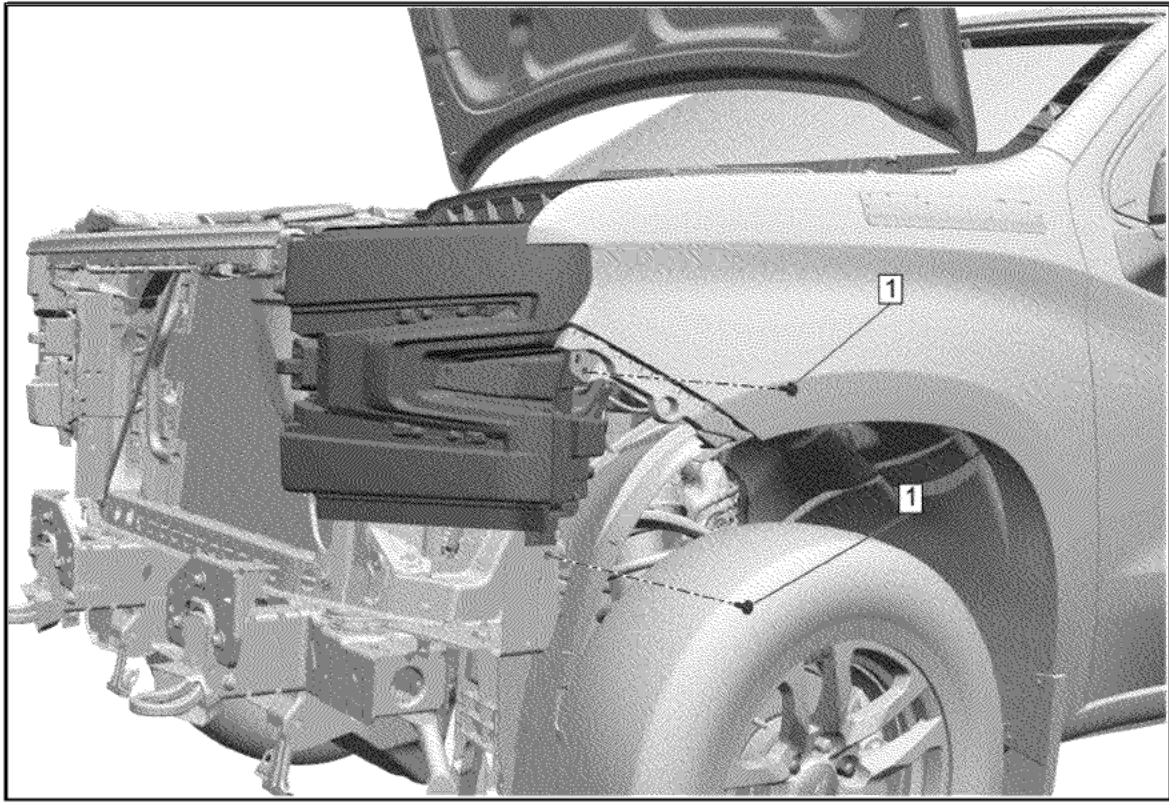

230. Headlamp Bolt - Left Side and Right Side (1) » Install and tighten [4x] — [Fastener Specifications](#)

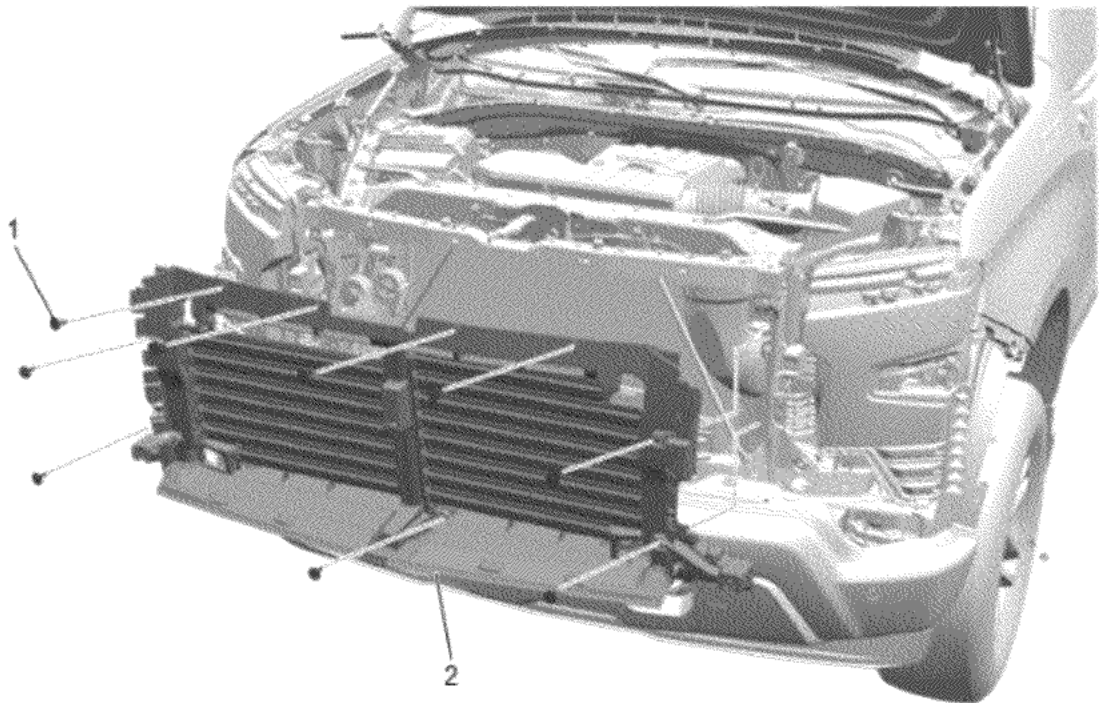

231. { If equipped } Connect and install the lower shutter harness.
232. Connect the electrical connector.
233. Front Bumper Shutter (2) » Install
234. { If equipped } Install the front driver info camera wiring harness retainer.
235. { If equipped } Connect the 2 wiring harness retainers onto the camera nozzle hose.
236. Front Bumper Shutter Bolt (1) Install and tighten [9x] — [Fastener Specifications](#)

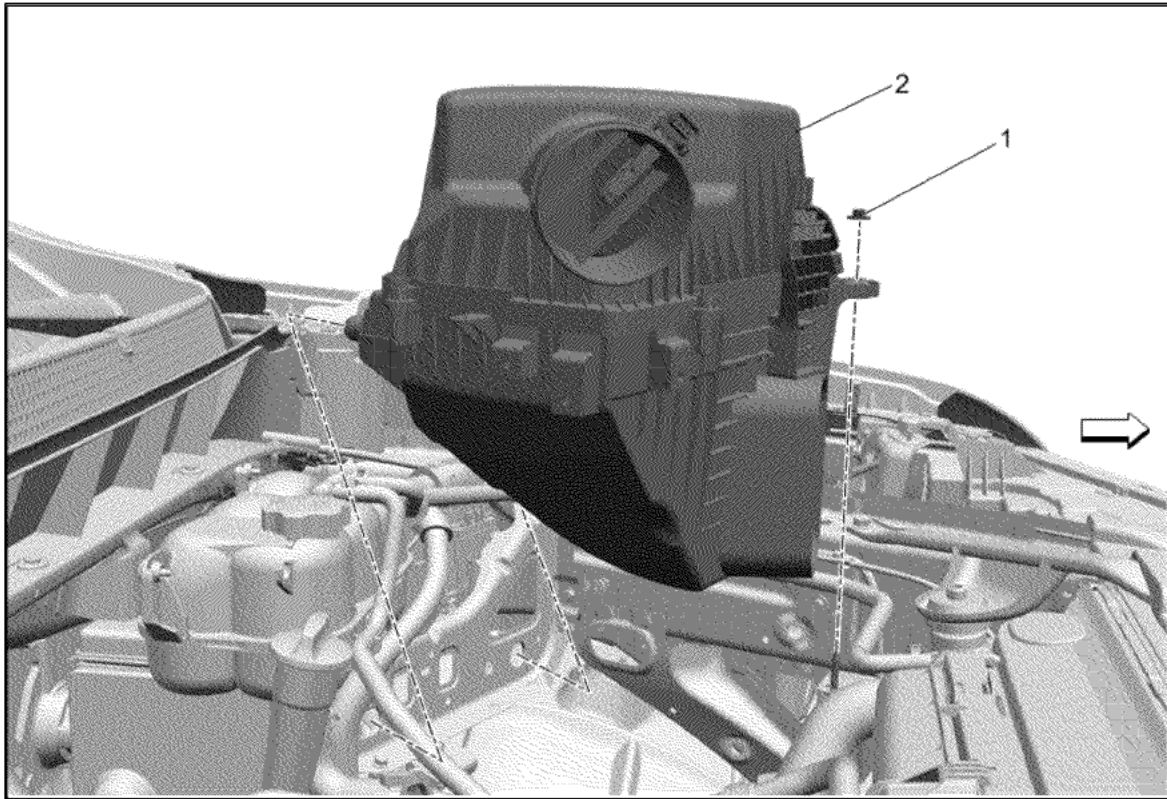

237. Air Cleaner Assembly (2) » Install
238. Air Cleaner Nut (2) » Install and tighten — [Fastener Specifications](#)

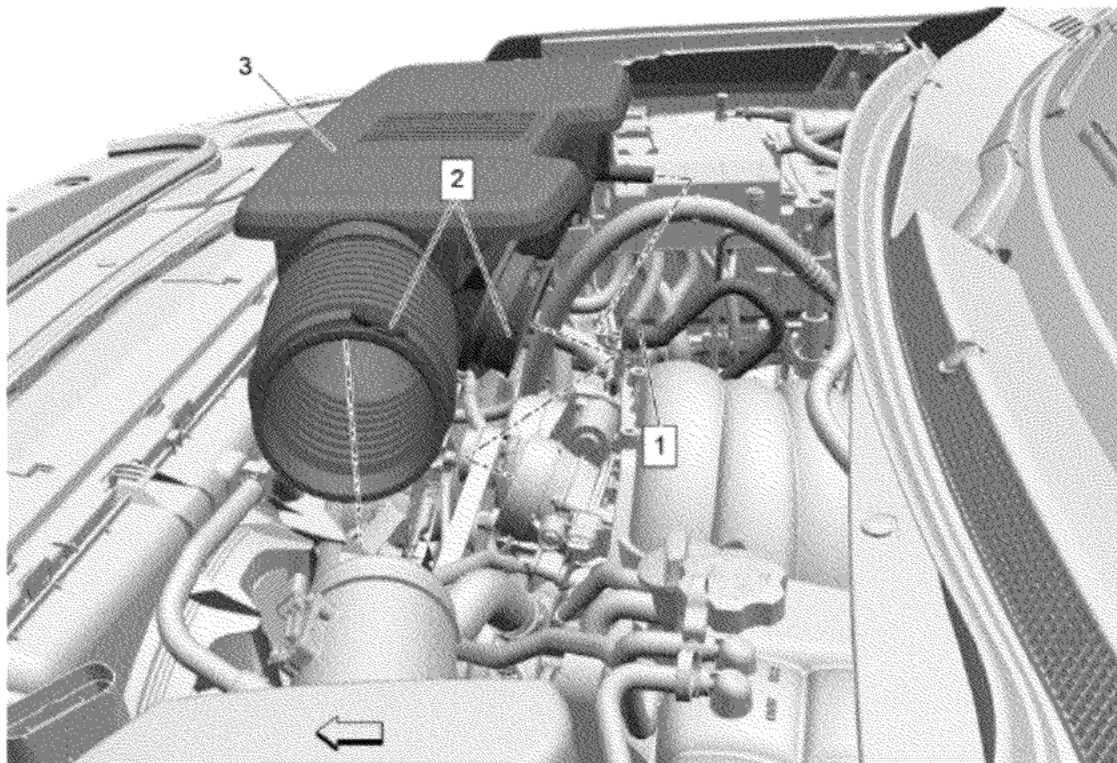

239. Air Cleaner Outlet Duct (3) » Install

240. Air Cleaner Outlet Duct Clamp (2) » Install and tighten [2x] — [Fastener Specifications](#)

241. Positive Crankcase Ventilation Fresh Air Tube (1) » Connect — [Plastic Collar Quick Connect Fitting Service](#)

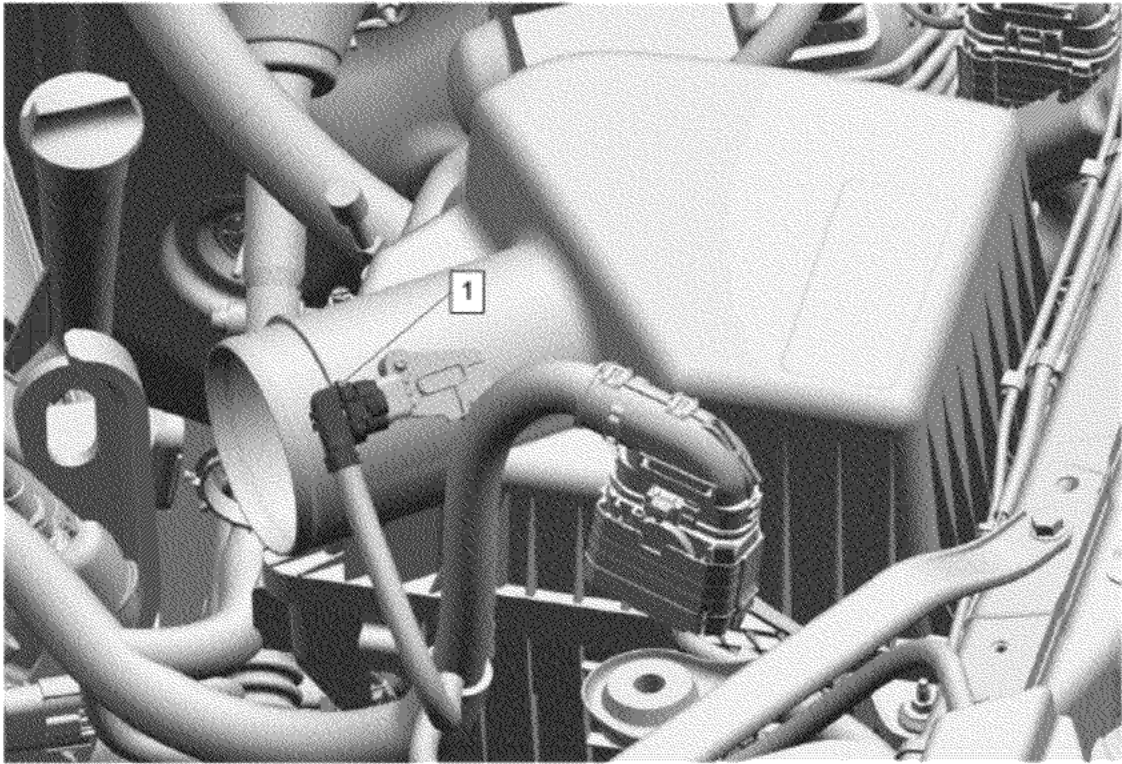

242. Connect the mass airflow sensor electrical connector (1) and install all engine wiring harnesses from the air cleaner assembly.

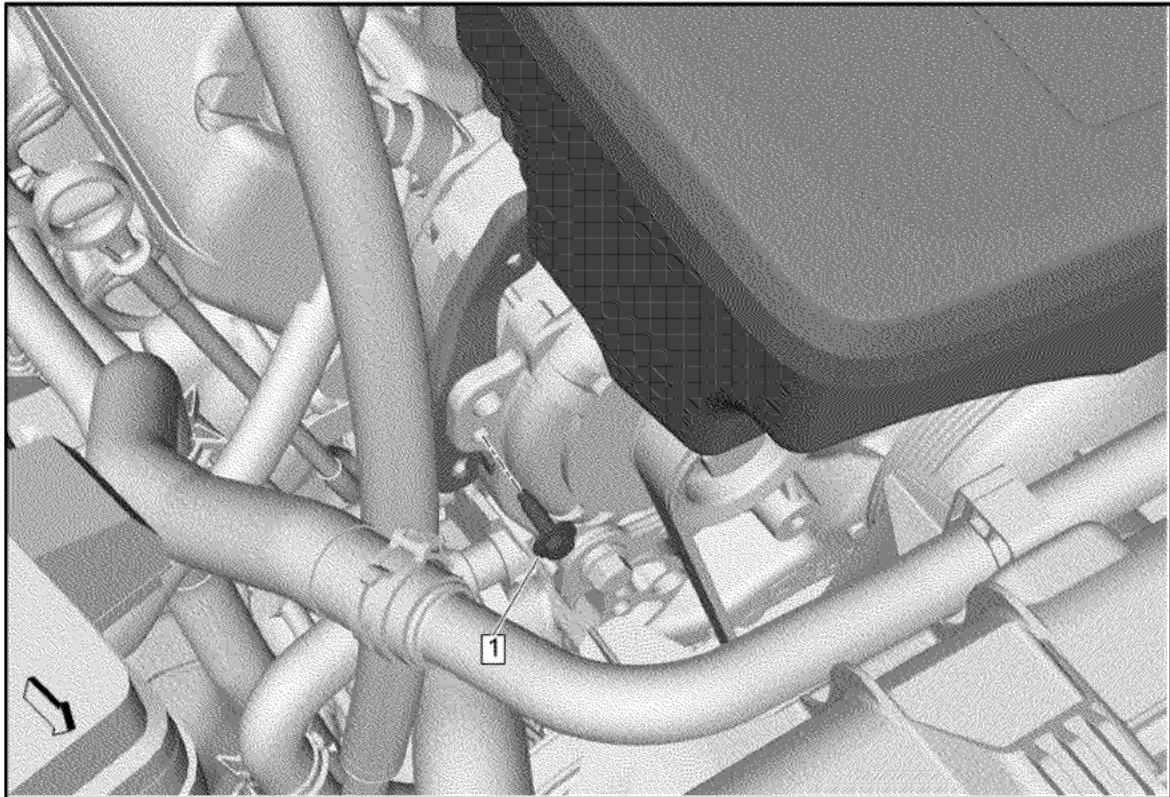

243. Air Cleaner Outlet Duct Bracket Bolt (1) » Install and tighten — [Fastener Specifications](#)

244. Engine Wiring Harness @ Air Cleaner Outlet Duct Bracket » Install

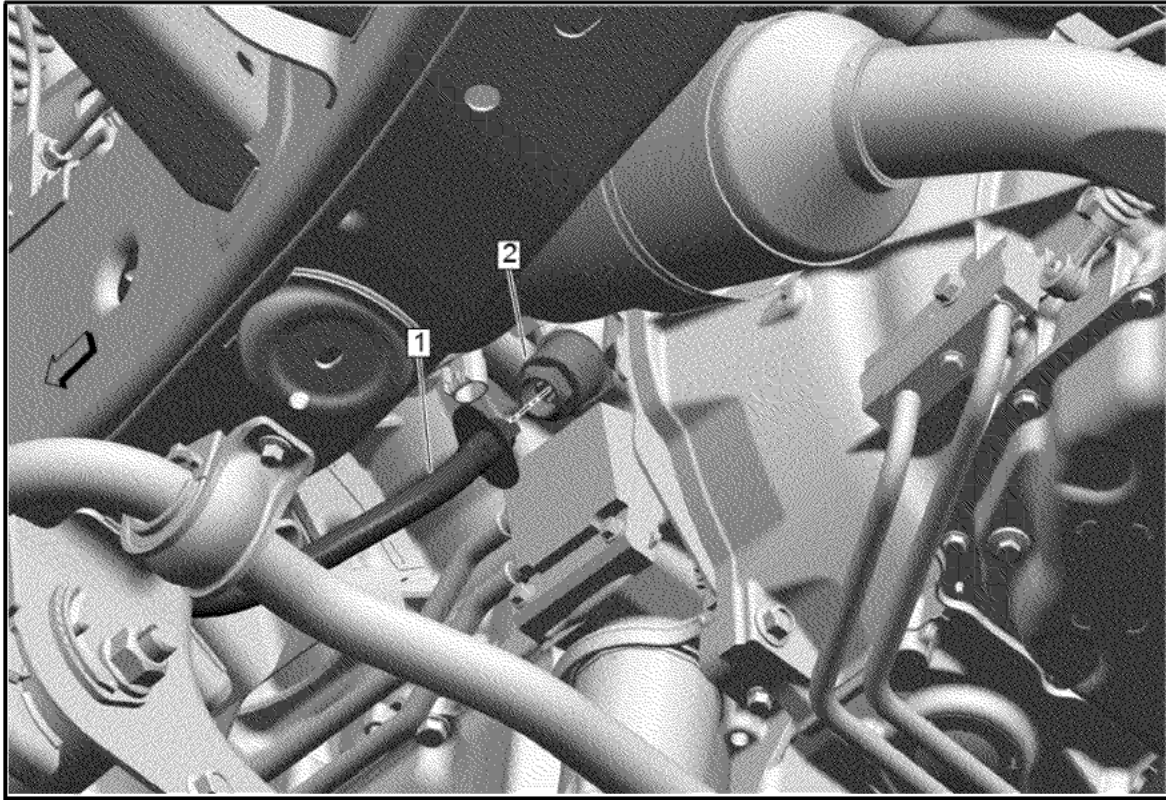

© 2025 General Motors. All rights reserved.

245. { If equipped } Engine Coolant Heater Cord (1) @ Engine Coolant Heater » Connect

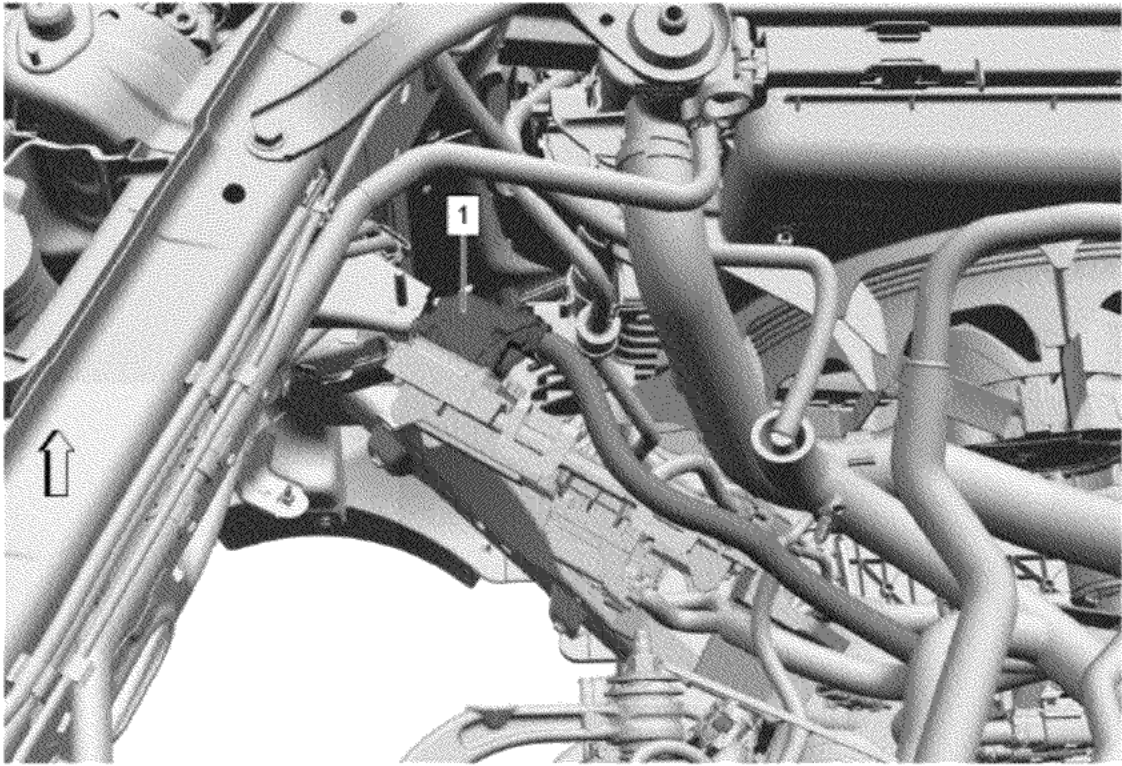

246. Connect the electrical connector. (1)

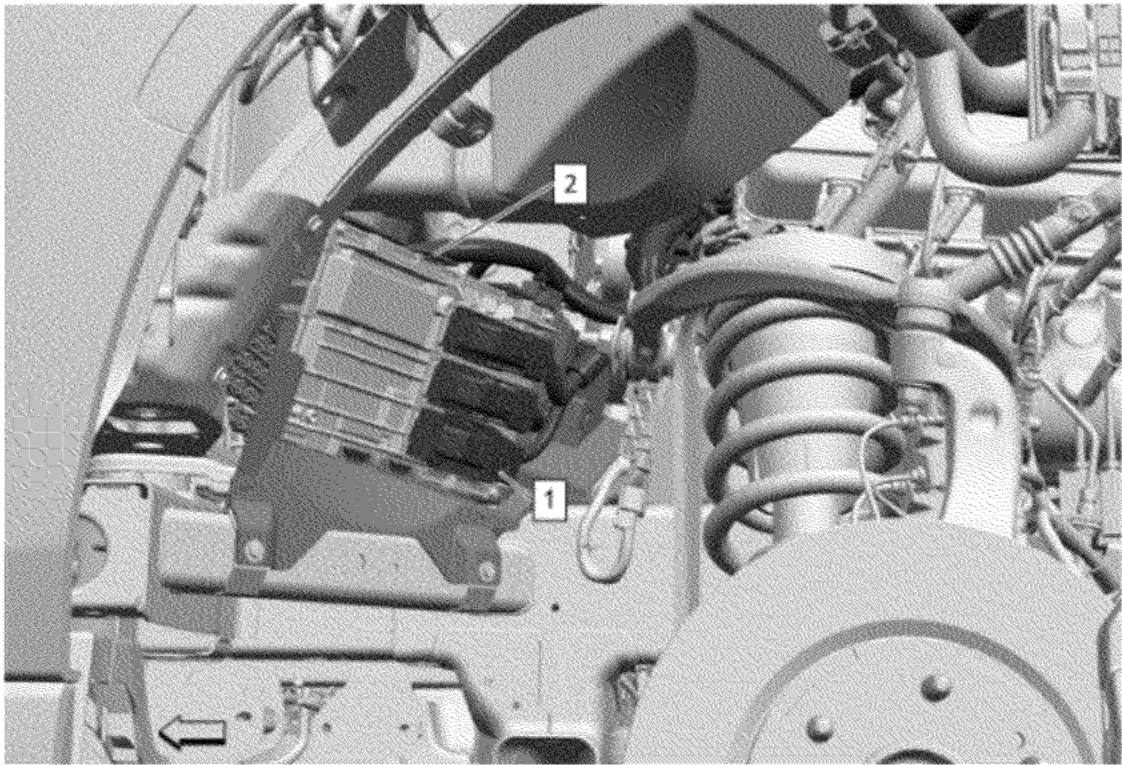

247. Connect the electrical connectors. (1)

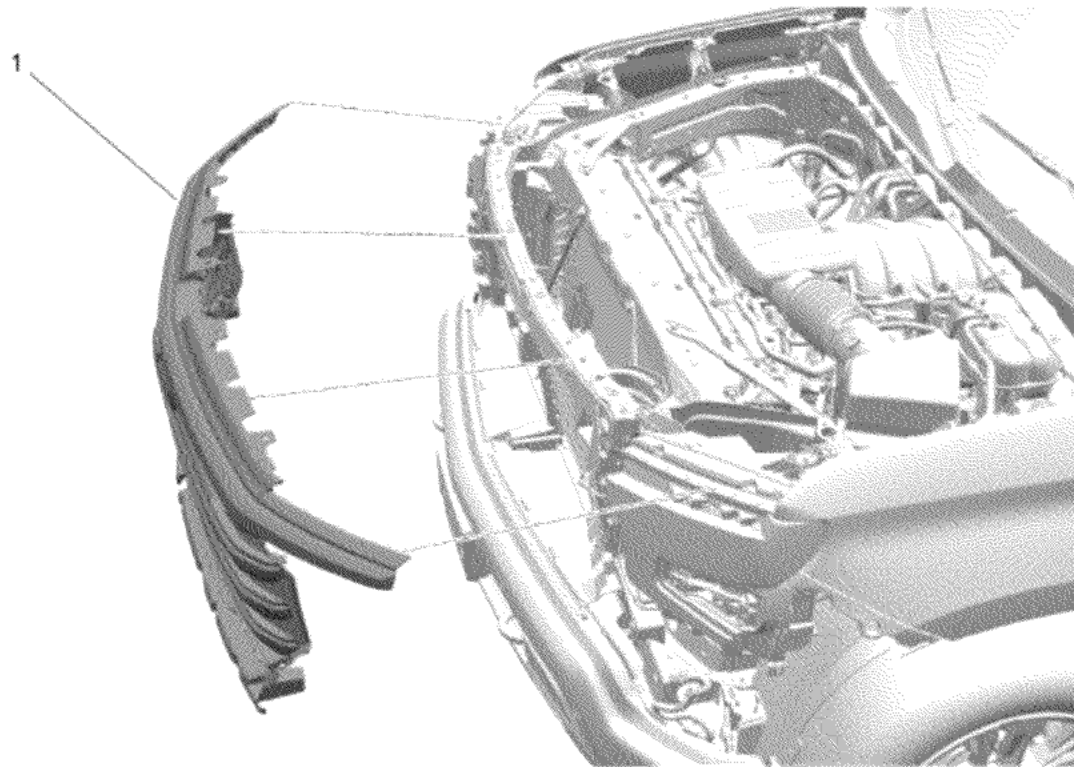

© 2025 General Motors. All rights reserved.

248. Front Grille (1) » Install

249. { If equipped } Front View Driver Information Camera Nozzle Hose » Connect

250. { If equipped } Connect the electrical connector.

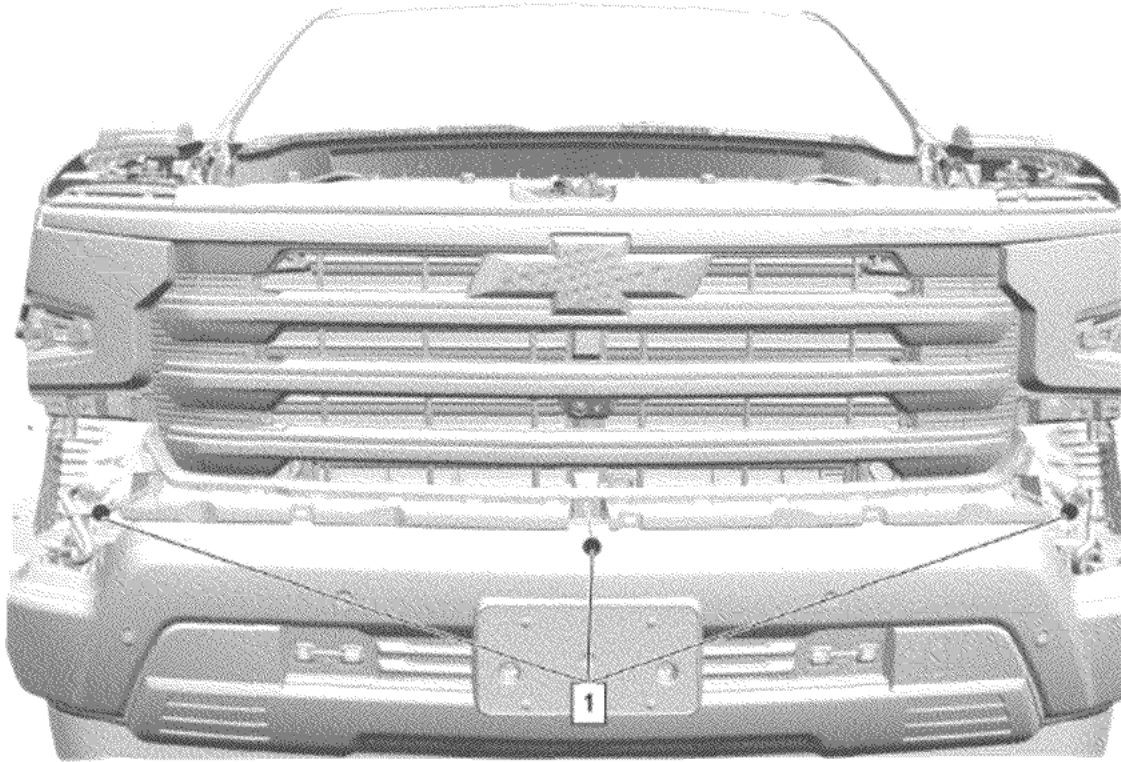

251. Front Grille Bolt (1) » Install and tighten [3x] — [Fastener Specifications](#)

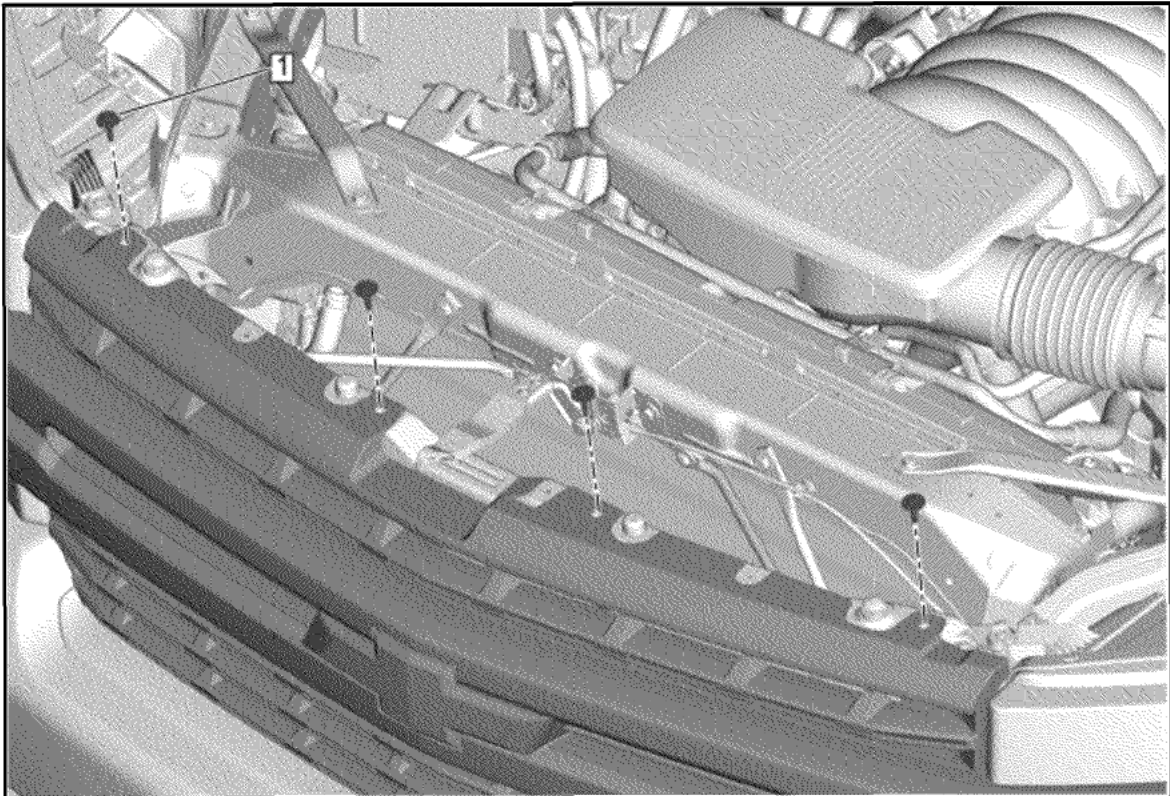

252. Front Grille Bolt (1) » Install and tighten [4x] — [Fastener Specifications](#)

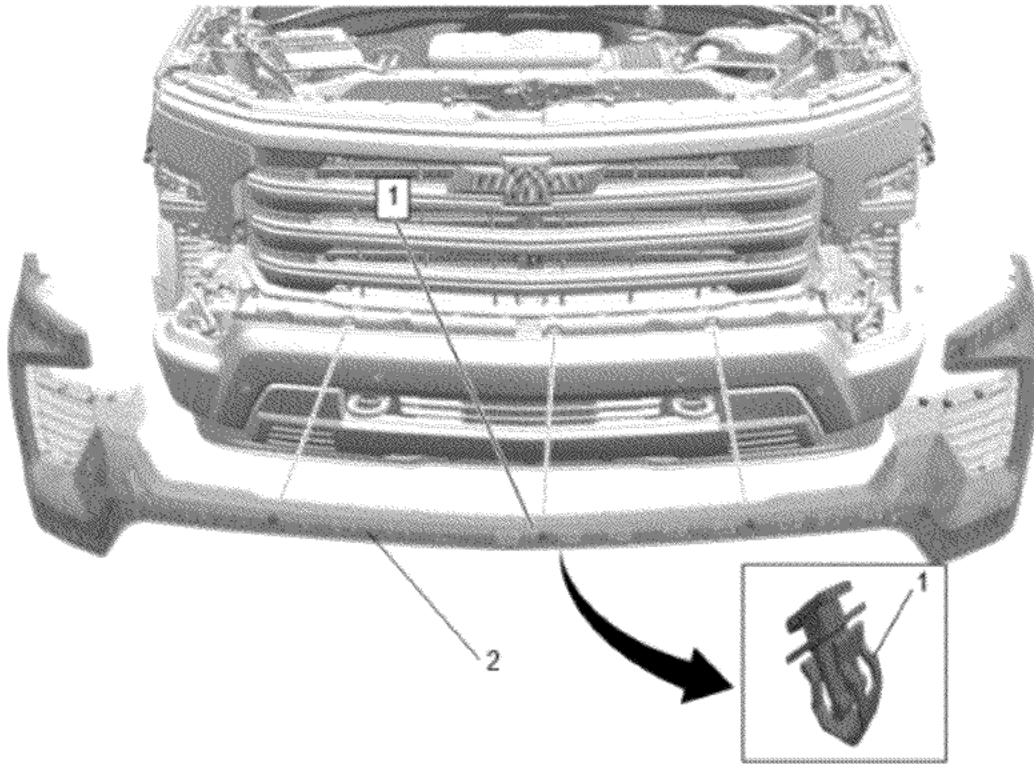

253. With the aid of an assistant, install the fascia. (2)

254. Install the 3 front bumper fascia reinforcement retainers(1) and the tabs.

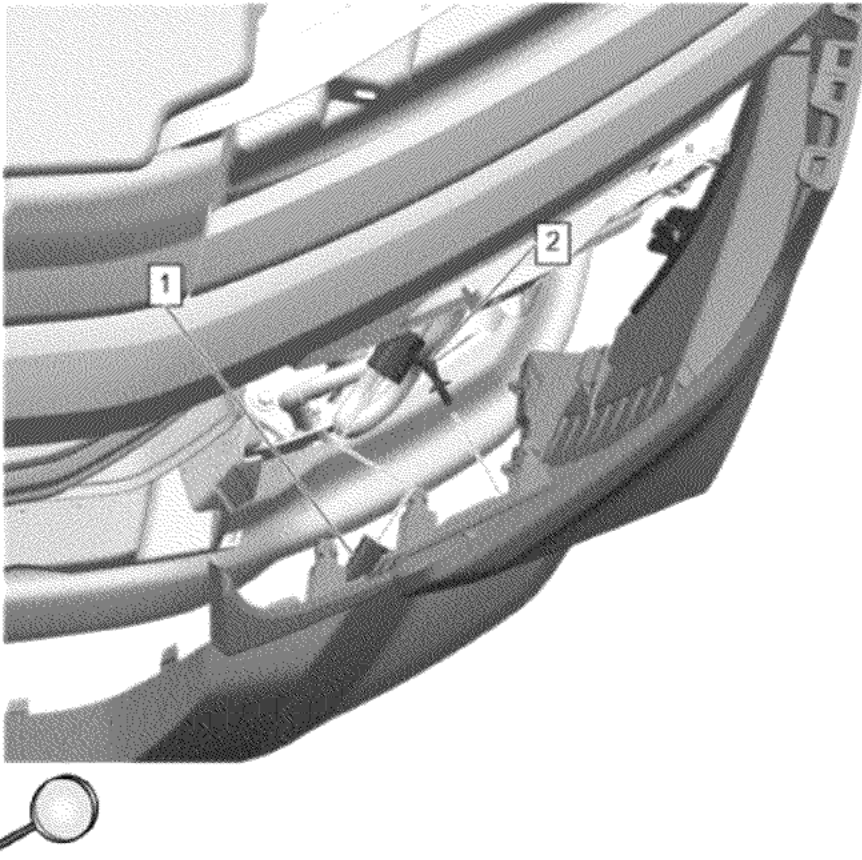

Note: Left side shown, right side similar.

- 255. { If equipped } Electrical Connector - Left Side and Right Side (1) » Connect [2x]
- 256. { If equipped } Wiring Harness Retainer - Left Side and Right Side (2) » Install [2x]

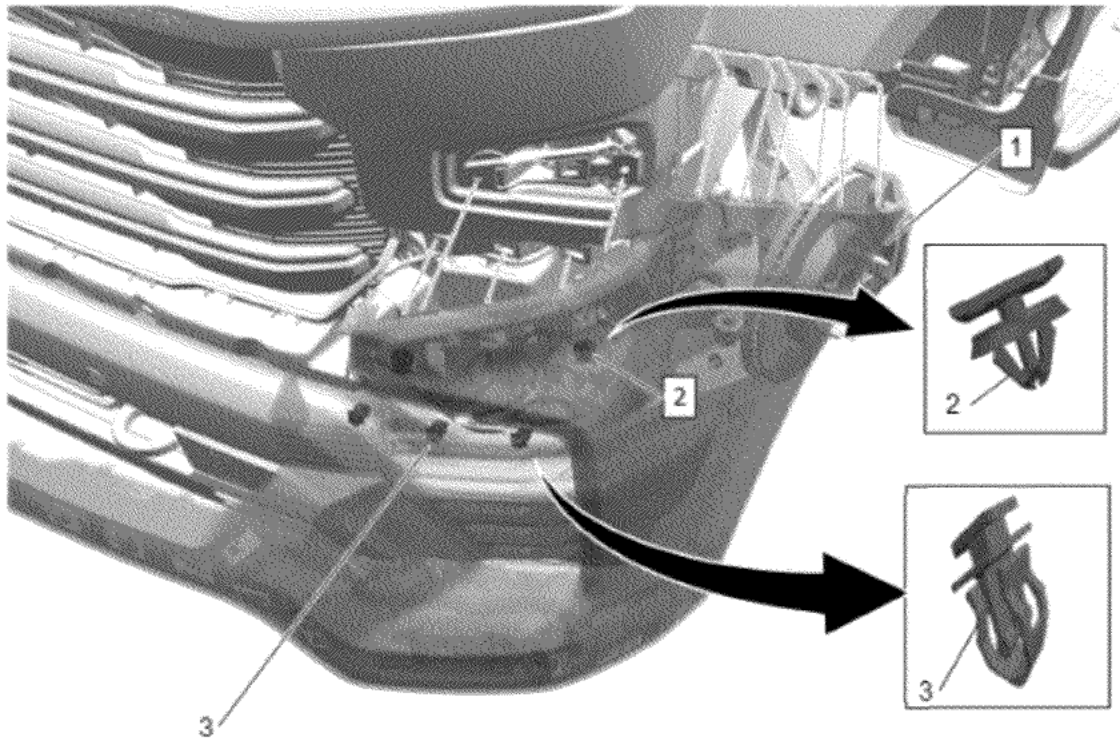

- 257. Front Bumper Fascia Reinforcement Retainer - Left Side and Right Side (3) » Install [6x]
- 258. Front Bumper Fascia Retainer - Left Side and Right Side (2) » Install [4x]
- 259. Secure the front bumper upper fascia (1) to the front bumper fascia guide.

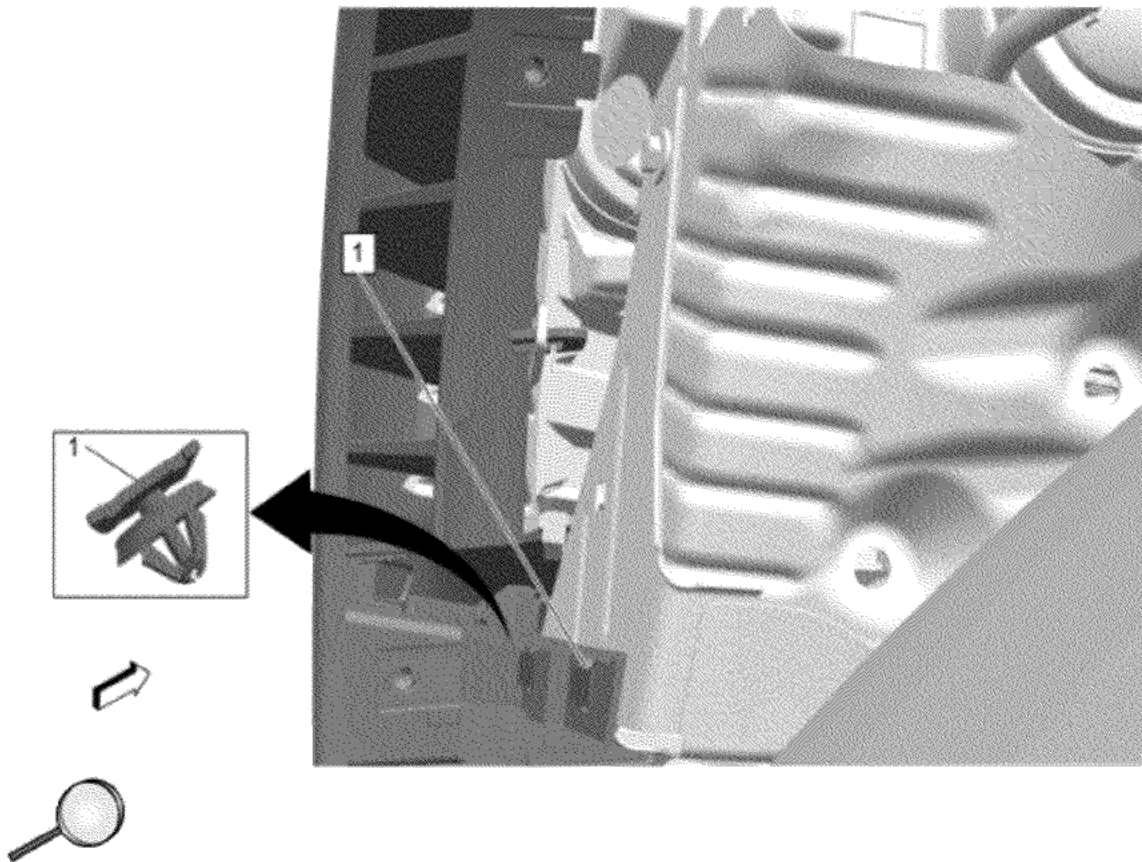

© 2025 General Motors. All rights reserved.

260. Front Bumper Fascia Reinforcement Retainer - Left Side and Right Side (1) » Install [4x]

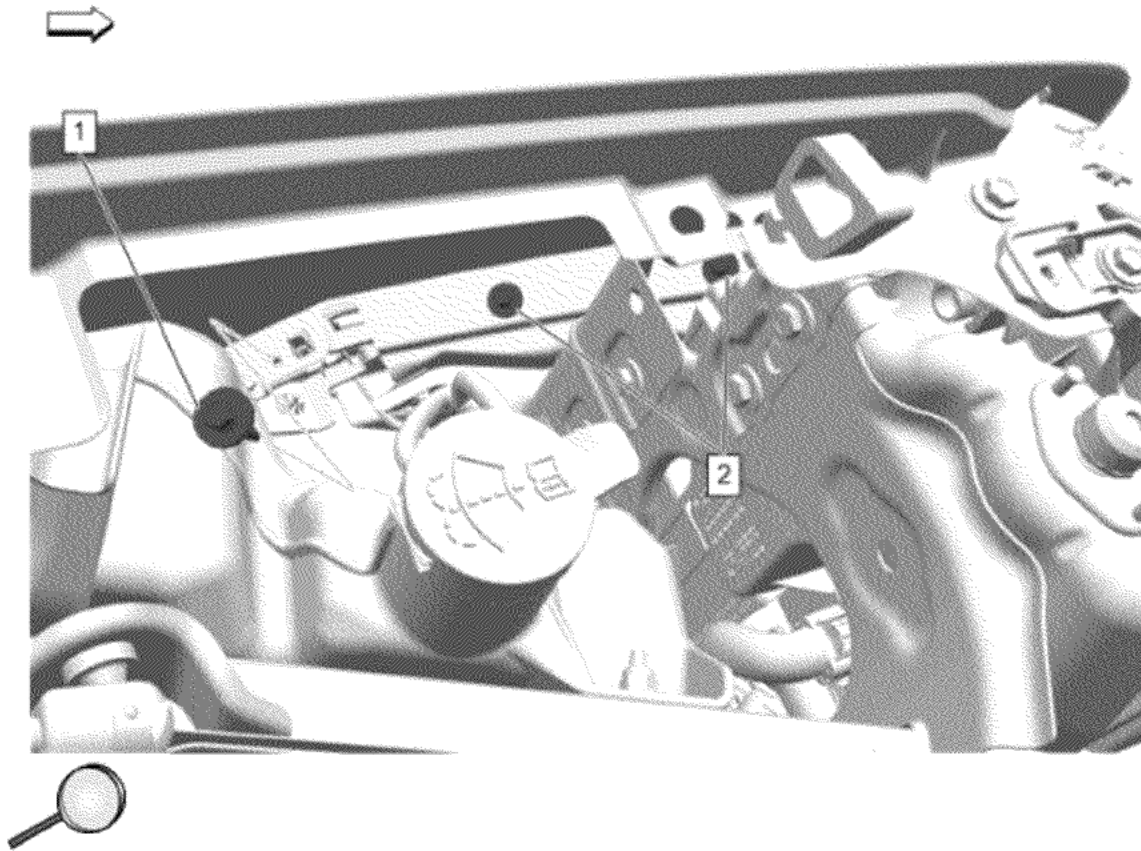

© 2025 General Motors. All rights reserved.

261. Front Bumper Fascia Guide Bolt - Left Side and Right Side (1) » Tighten [2x] — [Fastener Specifications](#)

262. Front Bumper Fascia Guide Bolt - Left Side and Right Side (2) » Tighten [4x] — [Fastener Specifications](#)

263. Remove the double layer of masking tape around the perimeter of the painted surfaces.

264. Using a 50/50 mixture of isopropyl alcohol and clean drinkable water with a clean towel, remove any left over adhesive residue from the masking tape.

265. Front Wheelhouse Liner - Left Side and Right Side (3) » Install [2x] — [Front Wheelhouse Liner Replacement](#)

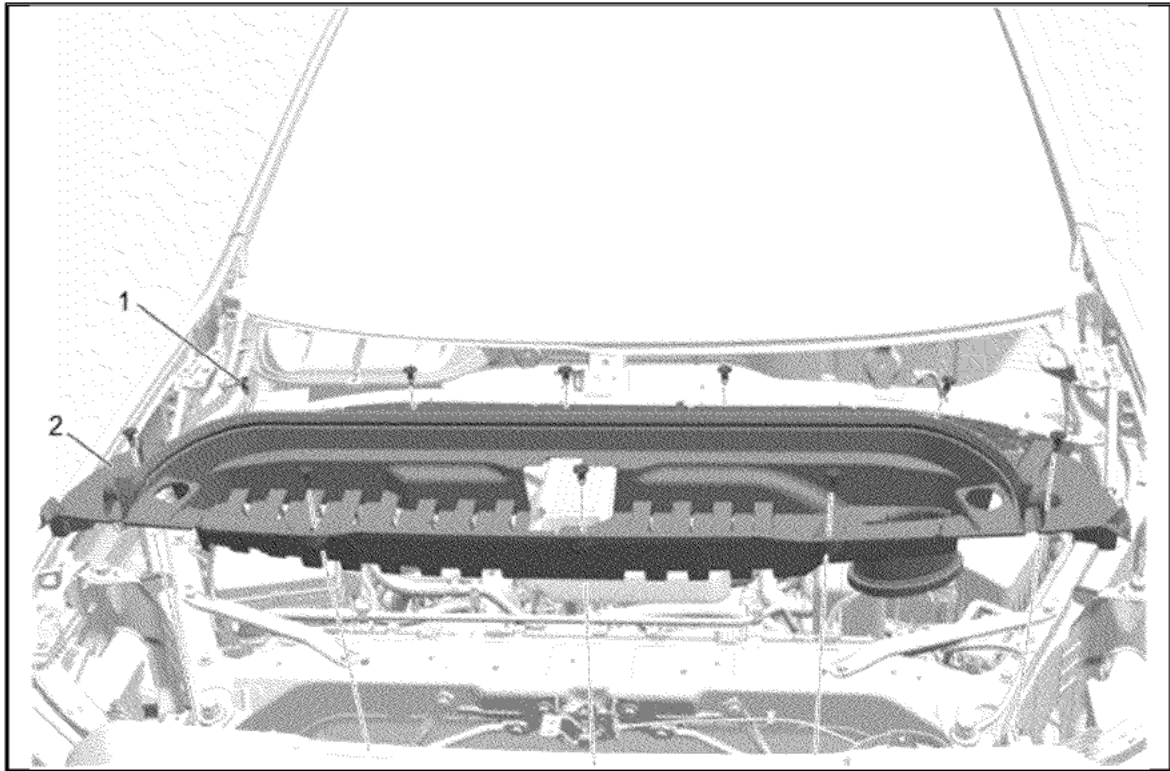

- 266. Intake Air Splash Shield (2) » Install
- 267. Intake Air Baffle Retainer (1) » Install [10x]

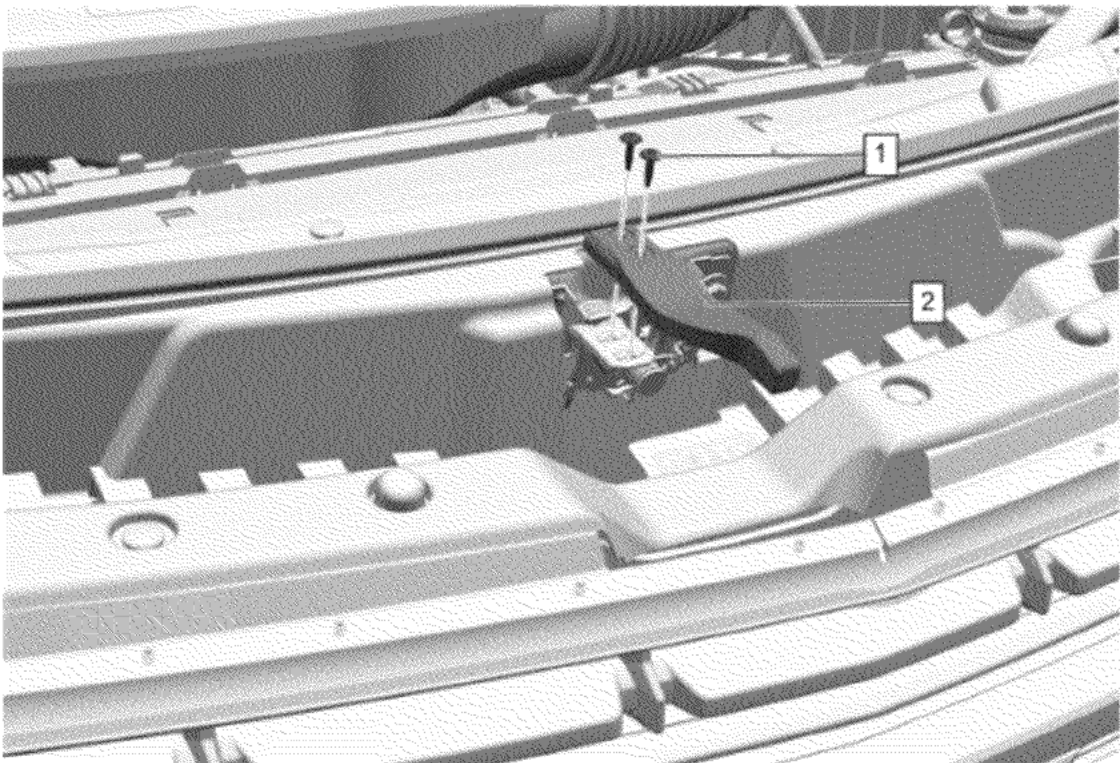

268. Hood Secondary Latch Release Handle (2) » Install

269. Hood Latch Actuator Bolt (1) » Install and tighten [2x] — [Fastener Specifications](#)

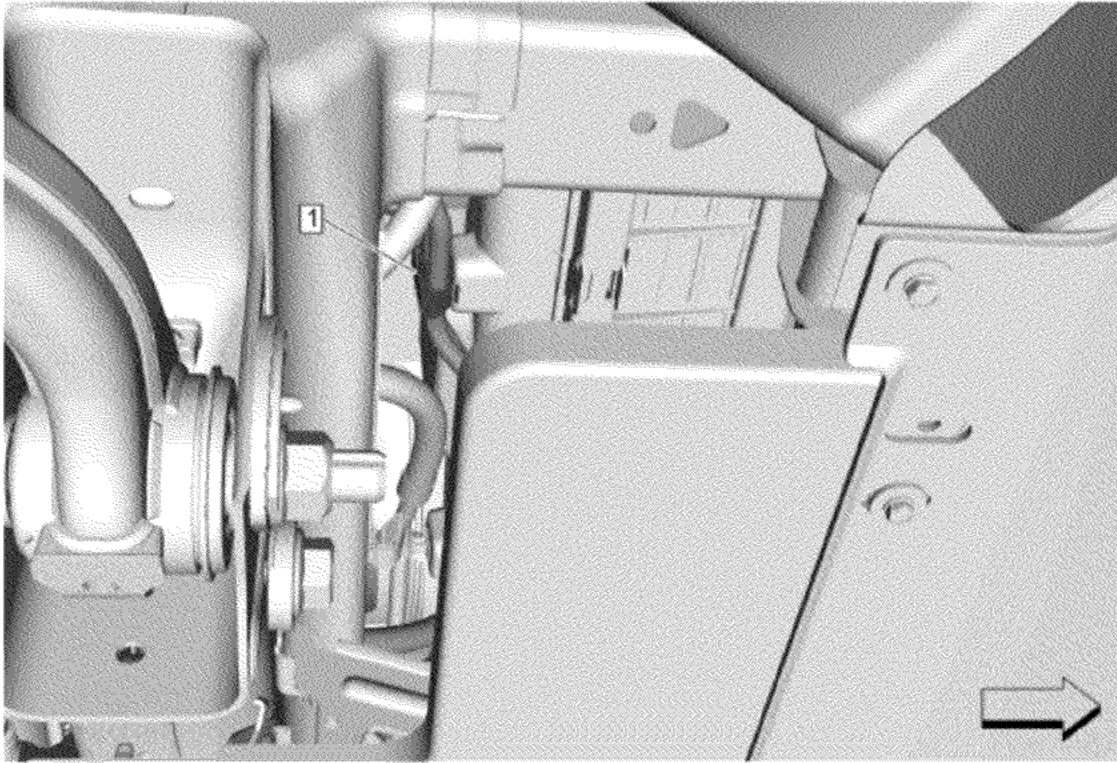

270. Engine Oil Cooler Hose Clip (1) » Secure

271. Install underbody panels as necessary. [Underbody Panel Component Locator](#)

272. Lower the vehicle.

273. Connect the battery negative cable. [Battery Negative Cable Disconnection and Connection](#)

274. Recharge the refrigerant. [Refrigerant Recovery and Recharging](#)

275. Inspect for refrigerant leaks.

276. Prelube is necessary if the engine is replaced or overhauled. [Engine Prelubing](#)

Caution: USE ONLY GE-47716 for Cooling System Draining and Filling. DO NOT USE Static Fill as it will result in damage to the engine.

277. Using the *GE-47716* Vac-N-Fill Coolant Refill Tool procedure only, fill the coolant system. [Cooling System Draining and Filling](#)

278. Install the oil fill cap.

279. Start the engine and check for fuel leaks.

280. Run the engine speed at about 1,000 RPM until the engine has reached normal operating temperature. Check the vehicle oil pressure gauge and confirm that the engine has acceptable oil pressure, listen for unusual noises. If necessary, install an oil pressure gauge and measure the engine oil pressure.

281. Inspect for oil leaks.

282. Perform a final inspection for the proper engine oil and coolant levels.

283. Perform the throttle body idle air flow compensation reset procedure. [Throttle Body Idle Air Flow Compensation Reset](#)

284. Perform the crankshaft position variation learn. [Crankshaft Position Variation Learn](#)

Caution: Refer to [Heated Oxygen Sensor Resistance Learn Reset Caution](#).

285. If any of the heated oxygen sensors are replaced, perform the heated oxygen sensor heater resistance learned values reset. [HO2S Heater Resistance Learned Values Reset](#)

286. After installation, aim the front headlamps. [Front Headlamp Aiming](#).