 HYUNDAI Technical Service Bulletin	GROUP RECALL	NUMBER 18-01-006
	DATE JANUARY, 2018	MODEL(S) 2011-2012MY SONATA (YF)
SUBJECT: SONATA GDI ENGINE INSPECTION / REPLACEMENT (RECALL CAMPAIGN 132)		

This TSB supersedes TSB# 17-01-046-1 and modifies the Parts Information and Service Procedure sections.

*** IMPORTANT**

***** Retail Vehicles Only *****

Dealers must perform this Recall Campaign whenever an affected vehicle is in the shop for any maintenance or repair.

When a vehicle arrives at the Service Department, access Hyundai Motor America's "Warranty Vehicle Information" screen via WEBDCS to identify open Campaigns.

Description: Certain 2011-2012 model year Sonata (YF) vehicles equipped with 2.4L and 2.0T GDI engines require an inspection to confirm normal operation. The inspection procedure will help indicate if the engine is operating normally or if an excessive connecting rod bearing wear condition in the engine crankcase may be present. If the vehicle continues to be driven with a worn connecting rod bearing, the bearing can fail and the vehicle could stall.

Perform the Inspection Procedure on Page 5 to inspect the engine for noise. The noise inspection will result in a **PASS, NO PASS, or RETEST**.

Follow the corresponding Service Procedure based on the noise inspection results:

Inspection Result	Service Procedure
PASS	Page 7
NO PASS	Page 8
RETEST	Page 8

Applicable Vehicles:

2011-2012MY Sonata (YF) vehicles produced at HMMA with 2.4L and 2.0T GDI engines (VIN begins with 5NP...)

Circulate To: General Manager, Service Manager, Parts Manager, Warranty Manager, Service Advisors, Technicians, Body Shop Manager, Fleet Repair

NOTICE

The inspection process will require the use of a Tablet-based GDS Mobile system (Samsung 10.1 or S2) with the latest GDS Mobile update. PC-based GDS is not supported.

Verify the latest GDS Mobile update is installed each day by connecting the GDS Mobile to the internet via WiFi and launching the GDS application. Update the GDS Mobile software if needed.

The verification process must be performed each day the GDS Mobile is used to complete this Campaign. The Special Inspection application will not function until it's verified.

GDS Mobile Information:

Update Version	Comment
Perform GDS Mobile update <u>daily</u>	See above Notice

SST Information:

Engine Noise Inspection Tools were shipped to each dealer.

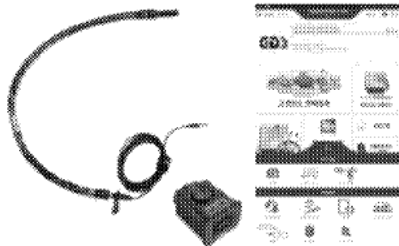
Description	Tool Part #	Image	Comment
Engine Noise Inspection Tool	G1XTD-CP005		For noise inspection
Torque Wrench Socket	09314-3Q100		Only needed if engine replacement required.
Injector Combustion Seal Ring Installer	09353-2B000		Refer to TSB 10-FL-019 for the detailed usage instructions

NOTICE

DO NOT disassemble or modify any components of the engine inspection tool. If any part of the tool is damaged, a new one should be ordered. Individual components of the tool cannot be ordered.

Parts Information:

Inspection Results / Procedure	Part Name	Part Number	QTY
PASS (Inspection with Oil Level Rod, Oil, and Oil Filter Replacement)	Rod Assembly-Oil Level	26611-2G050QQH	1 each
	Oil Filter	26300-35504	
	Gasket-Oil Plug	21513-23001	
NO PASS (Inspection and 2.4L Engine Replacement)	YF 2.4L Engine Assembly-Sub	21101-2GK50QQH	1 each
	YF 2.4L Service Kit 1	21111-2GK50QQH	
	Service Kit 2	21111-2GK70QQH	
	Oil Cooler Pipe & Hose Assy	25470-2G050QQH	
NO PASS (Inspection and 2.0T Engine Replacement)	YF 2.0T Engine Assembly-Sub	21101-2GK60QQH	1 each
	YF 2.0T Service Kit 1	21111-2GK60QQH	
	Service Kit 2	21111-2GK70QQH	
	Oil Cooler Pipe & Hose Assy	25470-2G650QQH	

Notes:

- 1) Select the appropriate parts for the corresponding inspection results and the applicable vehicle and engine type.
- 2) Replacement QQH engines are VIN-specific and should only be installed in the vehicle they were ordered.

Warranty Information:

Model	Op. Code	Operation	Op Time	Causal Part	Nature Code	Cause Code
Sonata (2.4L, 2.0T)	51CA21I1	Inspection with Oil, Oil Filter, and Oil Level Rod Replacement	0.7 M/H	21101 2GK50 QQH	Q75	ZZ1
Sonata 2.4L (non-Turbo)	51CA21R0	Inspection & Replacement, 2.4L Engine Long Block, Service Kits, Oil Cooler Pipe & Hose	8.5 M/H			
Sonata 2.0T (Turbo)	51CA21R1	Inspection & Replacement, 2.0T Engine Long Block, Service Kits, Oil Cooler Pipe & Hose	8.8 M/H			

Note: Submit Claim on Campaign Claim Entry Screen.

- If any part(s) are found in need of replacement while performing Recall Campaign 132 and the affected part(s) are still under warranty, please submit a separate claim using the same Repair Order. If the affected part(s) are out of warranty, request a Prior Authorization # for goodwill consideration prior to completing the Campaign.
- A claim for inspection 51CA21I1 will require a PASS inspection result.
- Before submitting a claim:
 - Confirm the vehicle's VIN matches the VIN in the test data (A).
 - Confirm the test result status is "Sent". If the status is "Pending", select the "Send All Pending" button to send the test results to HMA (B).

Special Inspection

Result Preview

* Date: 2015 1 1 ~ 2017 10 02 To search vehicle, please insert VIN or RO number. 🔍

Date	A	VIN	Model	Year	Engine	Mileage	RO Number	Re	B	Sent
2017-09-01 14:37:13			SONATA(YFA)	2012	G 2.4 GDI	3	3	PASS		Sent

Inspection Procedure:

- The Inspection Procedure will consist of preparing the vehicle and then performing an inspection using the **"Special Inspection"** function of the GDS Mobile application.

- Obtain the latest GDS Mobile update daily. The GDS Mobile must be connected to the internet via WiFi daily to confirm the latest software update is installed or the application will not function.
- Connect the GDS VCI to vehicle DLC.
- VCI should be updated with latest version and paired with GDS Mobile.
- Open the GDS Mobile App.
- Swipe up on the "More" tab at the bottom of the screen.
- Select the "Special Inspection" function.

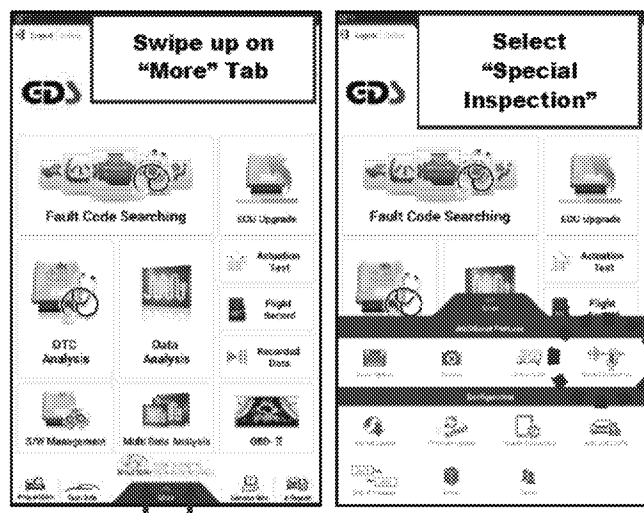

- Prior to inspection, the engine should be in a satisfactory running condition.

- Engine oil level should be in the normal range (shown at right).
 - Use Quaker State 5W-30 viscosity engine oil or other brand if not available (conventional type allowed with API SM / ILSAC GF-4 or higher service grade) to adjust the oil level if necessary.
- Engine should idle normally.
- Clear all DTCs

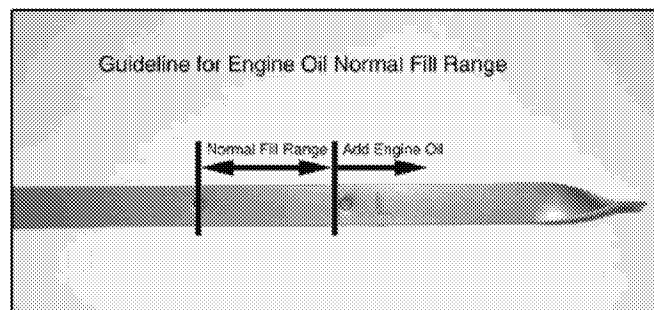

If the engine is running poorly, follow any related diagnosis and repair prior to performing this inspection procedure.

- Prepare the vehicle as follows before beginning the inspection:
 - All accessories off, including the audio system.
 - A/C must be off.
 - Engine coolant temperature above minimum temperature 85°C (185°F).
 - If the engine is cold, then warm the engine before testing.
 - Open the driver's front window.

4. Prepare the vehicle and Engine Noise Inspection Tool as follows:
- Remove the oil level rod assy (engine oil dipstick).
 - Insert the adapter (A) into the oil level gauge tube (dipstick tube).
 - Check for interference between the dipstick tube and the intake manifold.

Adjust the dipstick tube to create clearance between the tube and manifold if necessary.

- Attach the clip (B) to the hood latch.
- Connect the stereo jack (C) to the GDS Mobile headphone jack.
- Feed the inspection tool through the open driver's front window.

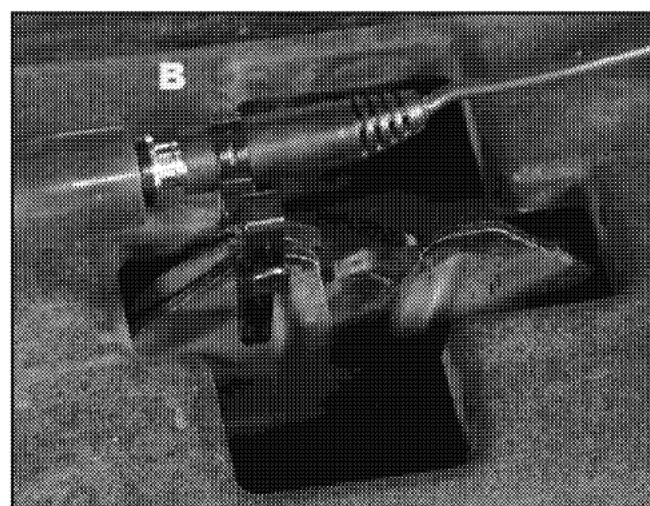
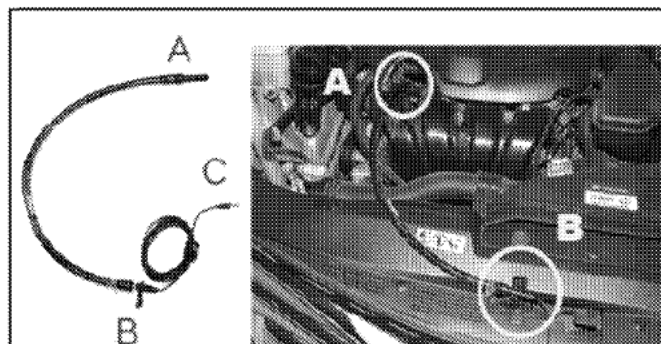
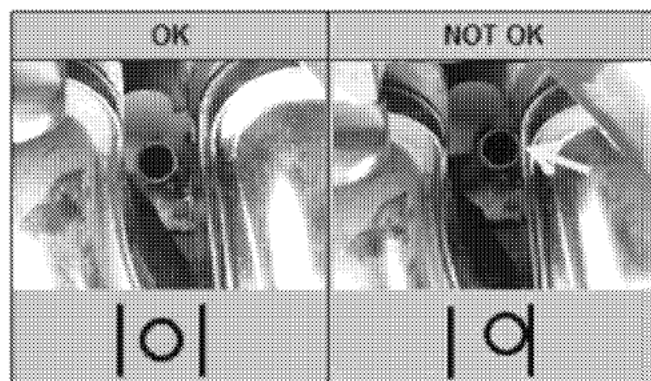

5. Follow the selection menus and on-screen prompts of the "Special Inspection" function to complete the Inspection Procedure.
- Do not tap, pinch or kink the Engine Noise Inspection Tool during the test.

NOTICE

For quality assurance purposes, an audio file of the engine noise and the inspection results will be sent to HMA.

6. After the Inspection Procedure is complete, the application will display **PASS**, **NO PASS**, or **RETEST**.

- This information will be sent to HMA when the GDS Mobile Tablet is connected to a WiFi network.

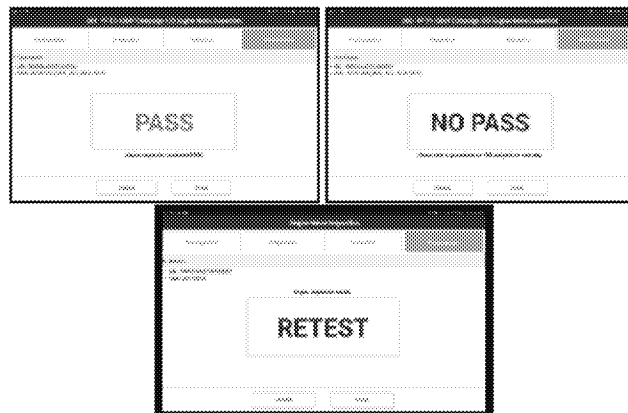

For **PASS**, **NO PASS**, or **RETEST** proceed to the appropriate **Service Procedure** in the following pages that correspond to the **Inspection Results**.

Inspection Result	Service Procedure
PASS	Page 7
NO PASS	Page 8
RETEST	Page 8

NOTICE

The GDS can store a maximum of 5 tests while the device is offline (disconnected from Wi-Fi). In order to perform further tests, connect the GDS to Wi-Fi and select the "Send All Pending" button to send the pending test results to HMA.

Service Procedure (Inspection Results = PASS)

1. If the inspection results in a **PASS**, then an engine replacement is NOT required.



2. Replace the engine oil (4.8 quarts), oil filter, and drain plug gasket.
3. Replace the current Oil Level Rod Assembly with the new campaign part.
 - Remove and discard the existing Oil Level Rod Assembly (engine oil dipstick).
 - Install new **ORANGE** handle Oil Level Rod Assembly (P/N 26611-2G050QQH)

Note: Replace the dipstick **ONLY** if the current dipstick's handle is yellow. Do not replace if it's red.

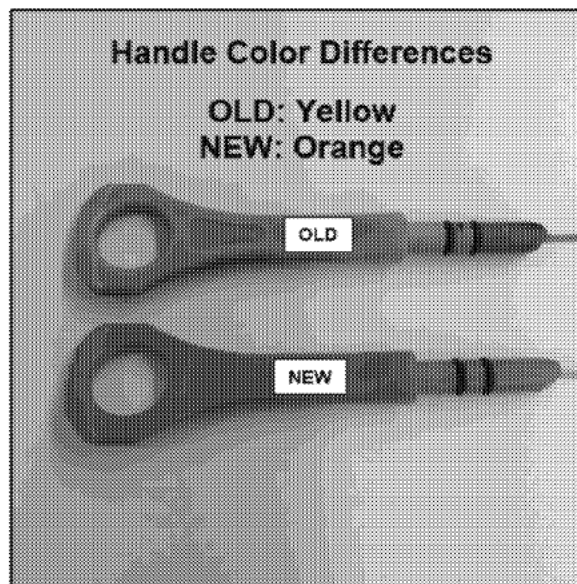

4. Start the engine and allow it to run for 10 seconds. Turn off the engine and after a few minutes adjust the engine oil level to near the "F" mark as shown in the picture.
 - Use Quaker State 5W-30 viscosity engine oil or other brand if not available (conventional type with API SM / ILSAC GF-4 or higher grade).
 - Do not overfill.

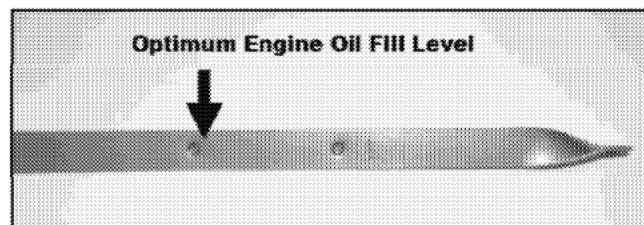

5. The Service Procedure for **Inspection Results = PASS** is now complete.

Service Procedure (Inspection Results = RETEST or NO PASS)

1. If the inspection results in a **RETEST** or **NO PASS**, perform the following steps to **remove any sources of interfering noise** and then **retest the vehicle**.
 - a) Is there any abnormal noise that's intermittent or does not follow engine RPM?
 - If so, check for the source of the noise from other components such as the exhaust system, engine mounting points, lines and harnesses. Adjust as necessary.
 - b) Is there any abnormal noise that could be from engine-driven accessories?
 - If necessary, remove the serpentine belt to isolate all belt-driven accessories to the engine assembly. Limit engine run time during any inspection. Adjust as necessary.

NOTICE

After completing steps a) and b) above to remove any sources of interfering noise, perform the Inspection Procedure again.

- If re-inspection results in a **PASS**:
 - Perform Service Procedure for Inspection Results = PASS.
- If re-inspection results in a **RETEST**:
 - Perform Service Procedure for Inspection Results = RETEST or NO PASS again.
- If re-inspection results in a **NO PASS**:
 - Follow the procedures in step c) below to request a Prior Authorization #.

- c) If the re-inspection still results in a **NO PASS** after retesting the vehicle:
 - **Do not inform the customer that they will need a new engine until approved by Warranty Prior Approval (PA).**
 - **Do not order the engine until approved by Warranty Prior Approval (PA).**
 - Immediately upload the test results for PA review.
 - If the tablet is not connected to a Wi-Fi network at the time of the test, the result will not be automatically uploaded. Please ensure test results are uploaded as inspections are performed to avoid any delay in PA review.
 - Go to the WebDCS PA Request screen. The PA request will be auto-created and saved. Edit the PA request if needed and submit to PA for review.
 - PA will review the audio file within 1 business day to ensure validity of the test.
 - If there are no anomalies in the audio files, the PA agent will approve the PA request and advise the dealer to proceed with the engine replacement.
 - If there are anomalies in the audio files, the PA agent will request for the test to be performed again and for the test results to be uploaded for review.

2. Follow the published Service Information from the applicable **Shop Manual** to remove the Sub Engine Assembly from the vehicle.

Shop Manual Section Location:

Engine Mechanical >
 Engine And Transaxle Assembly >
 Engine And Transaxle Assembly >
Repair Procedures

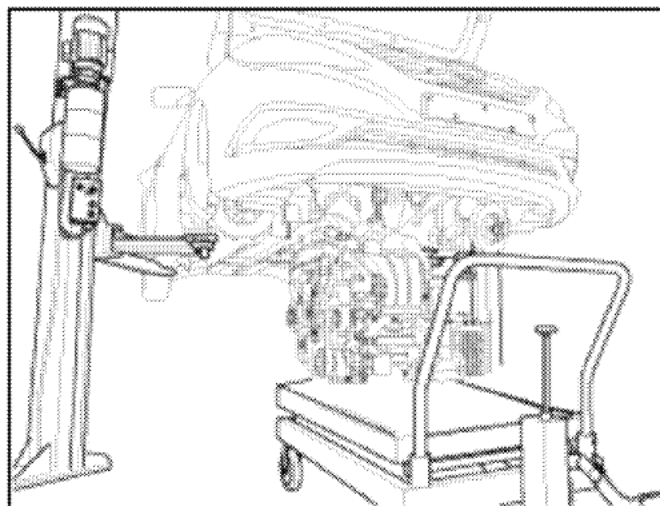

NOTICE

Record the audio station presets (XM, AM, FM, etc) prior to disconnecting the battery.

3. The shipped contents of the service replacement "QQH" Sub Engine Assemblies differ from traditional service replacement engines and must be specially prepared prior to installation.

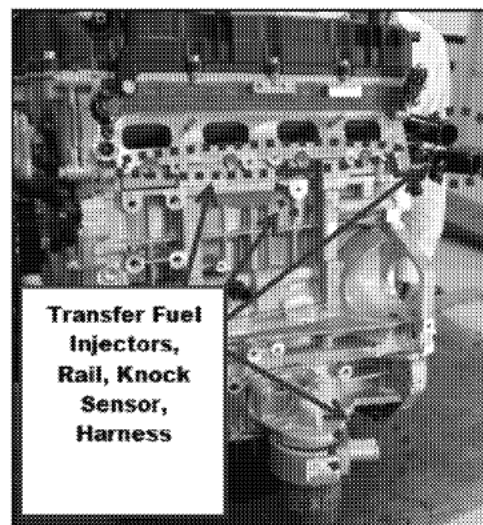
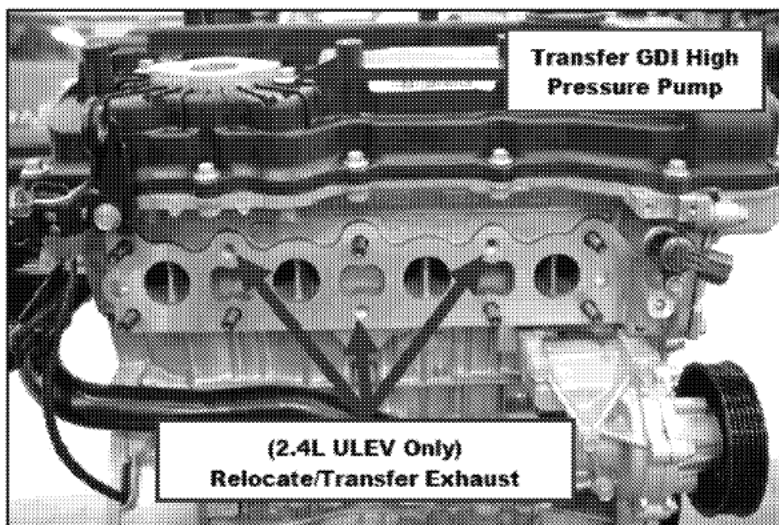

NOTICE

Some components from the existing engine must be transferred to the new engine. Be careful to preserve the vehicle's original parts. Install all of the newly supplied contents of the applicable Service Kits.

4. **For 2.4L with ULEV / FED emissions only**
All 2.4L engines with part numbers in the Parts Information section are produced with the exhaust manifold studs configured for SULEV / CAL emissions package.

SULEV /
CAL Spec

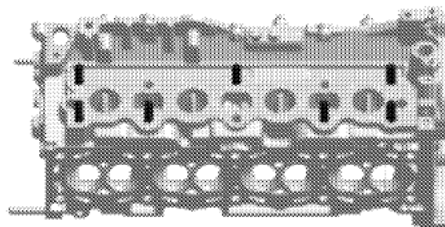

Exhaust Stud Position Relocation Information

2.4L vehicles with a ULEV / FED emissions package require 2 exhaust studs to be relocated on the new engine and 1 exhaust stud transferred over from the old engine.

- Use a commercially available stud removal tool or use the double-nut technique to complete this step.

ULEV /
FED Spec

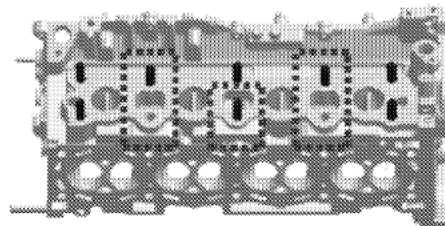

5. Remove and reinstall the engine Knock Sensor from the old engine to the new engine.

(Knock Sensor Fastener)

Tightening torque: 21Nm (15.5lb-ft)



6. Follow the published procedure outlined in **TSB 10-FL-019** to remove and reinstall the following GDI high pressure fuel system components from the existing engine to the new engine:
- GDI High Pressure Pump
 - Fuel Injectors (4)
 - Fuel Delivery (Rail) Pipe

The corresponding Service Kit 2 will supply the required new parts per TSB 10-FL-019 to complete the transfer of the above existing parts.

⚠ CAUTION

Follow TSB 10-FL-019 carefully and replace the following newly supplied parts from the Service Kit 2:

- Mounting flange O-ring (for High Pressure Pump)
- O-rings, Backup Rings, Washer Seals, Combustion Seal Rings, and clips (for Fuel Injectors)
- Fuel Pipe (between High Pressure Pump and Delivery Pipe)

In addition, Service Kit 2 includes (1) Exhaust Pipe Gasket. Install this new gasket when attaching the front and center muffler assemblies together during the engine installation.

7. Install new oil cooler hoses.
8. Reconnect and reinstall the engine front harness as shown.
 - Be sure to properly route the opposite end of the harness end down towards the front of the engine.
9. Install newly supplied Oil Level Guide and Oil Level Rod Assemblies to the new engine.
 - Be sure to install the NEW Oil Level Guide (dipstick tube) to the NEW engine.
 - Install the NEW Oil Level Rod Assembly (dipstick) to the NEW engine.

NOTICE

The engine is shipped without oil and engine oil must be added at a later step.

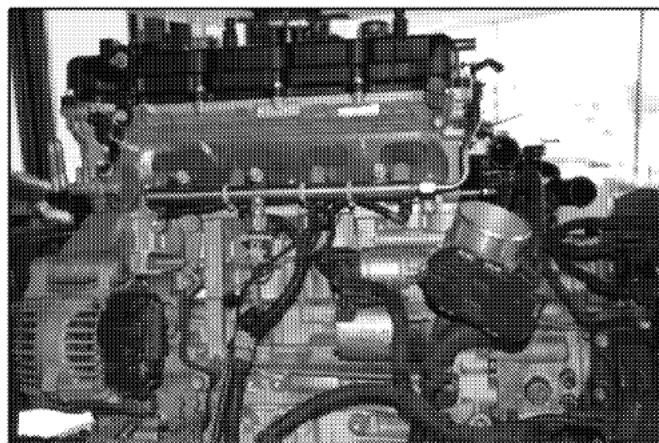
**Handle Color Differences**

NEW-QQH Engine: Red
OLD: Yellow

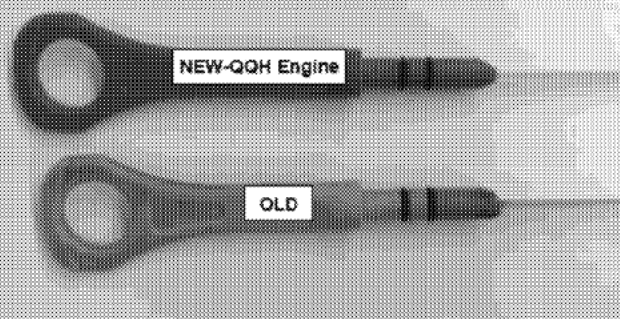

10. Follow the published Service Information from the applicable **Shop Manual** to reinstall the Sub Engine Assembly.

Shop Manual Section Location:

- Engine Mechanical >
- Engine And Transaxle Assembly >
- Engine And Transaxle Assembly >
- Repair Procedures

NOTICE

Be sure to replace the following newly supplied parts from the applicable engine Service Kit:

- Oil Level Rod & Oil Level Guide Assy.
- Intake Manifold Gaskets (4)
- Exhaust Manifold Gasket
- Fuel Tube Assembly
- (2.0T Only) Turbo Oil Feed Hose & Pipe
- (2.0T Only) Turbo Oil Drain Gasket (2)
- (2.0T Only) Oil Drain Gasket
- (2.0T Only) Gasket (2)

NOTICE

If the torque converter has moved from the fully inserted position, carefully push inward and rotate the torque converter until the converter is recessed approximately 9/16 - 5/8" (14 -16 mm) into the transaxle case when reinstalling the automatic transaxle.

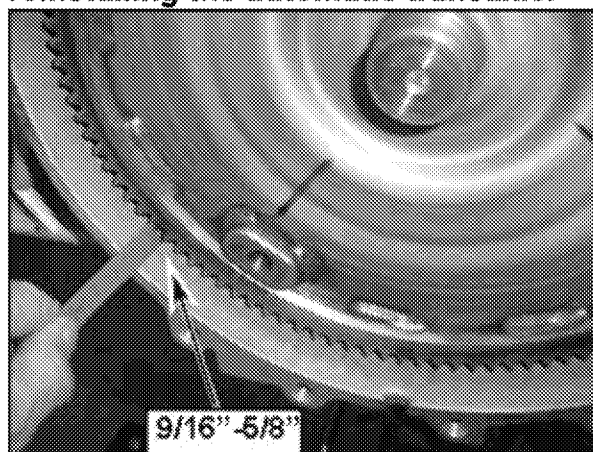

11. Connect the (2) oil coolant hoses between the oil cooler and the water temperature control assembly.
- Fill the cooling system with 50/50 ~ 70/30 (Water/Anti-Freeze) coolant mixture.
12. Use Quaker State 5W-30 engine oil or other brand if not available (conventional, synthetic blend, or full synthetic type with API SM / ILSAC GF-4 or higher service grade) to fill the engine crankcase.
- Add 5.8 quarts for the initial dry fill of the engine.
 - With the fuel system disabled temporarily, crank the engine for several seconds to prime the lubrication system prior to starting the engine.
13. Start the engine to warm it up and begin the cooling system air bleeding process.
- During this time, check for any leaks.
 - After the engine has warmed up to normal operating temperature, turn the engine off, wait a few minutes, and then adjust the engine oil level to near the "F" mark as shown in the picture.
14. When all fluids have been fully filled and all work quality checks are completed:
- Set the customer's audio station presets.
 - Relearn the Steering Angle Sensor using the GDS.
 - Reset the engine adaptive values using the GDS.
 - Perform a short road test to relearn the initial adaptive values.
 - Verify normal vehicle drivability.

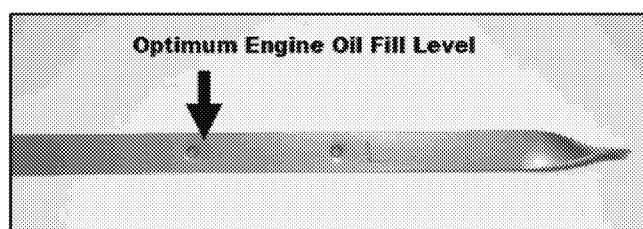

15. Prior to discarding the removed engine, damage the short block casting to prevent reuse by performing the following:
- Locate the starter motor mounting tab.
 - With a large mallet, strike firmly at the center of the tab (as shown in RED) to break off the mounting tab.

⚠ CAUTION

Always wear eye protection and perform this step in an open area with ample free space.

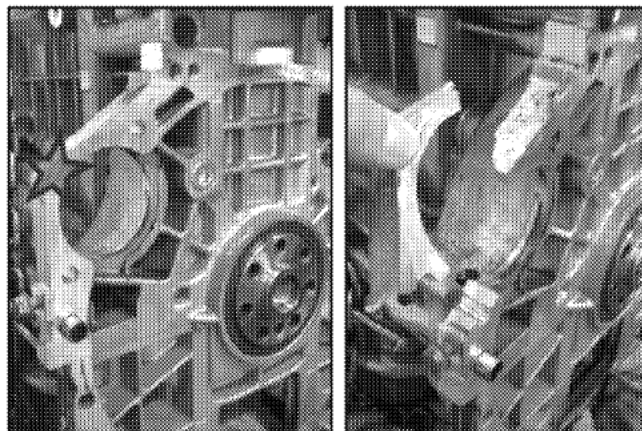

16. The Service Procedure for Inspection Results = **NO PASS** is now complete.