



# Service Bulletin

Bulletin No.: 18-NA-355

Date: May, 2019

## TECHNICAL

**Subject:** Shake and/or Shudder During Light Throttle Acceleration Between 25 and 80 MPH (40 and 128 KM/H) at Steady Speed

**Attention:** This Bulletin only applies to vehicles sold in the U.S., Canada and Middle East Operations (MEO). Mexico and Export Regions should follow Bulletin 19-NA-018.

Brand:	Model:	Model Year:		Date Breakpoint:		Engine: (2.0L, 2.5L, 3.0L, 3.6L, 5.3L, 6.2L)	Transmission: (8L45, 8L90 Automatic)			
		from	to	from	to					
Cadillac	ATS	2016	2019	SOP	Feb. 1, 2019	LCV, LGX, LTG, LT4, LF4	M5N, M5T, M5U			
	CTS				EOP			LGX, LGW, LTG	M5N, M5X	
	CT6	2016	2018			L86	M5U			
	Escalade Models	2015	2017		Feb. 1, 2019			LGX, LTG, LT1	M5T, M5U	
Chevrolet	Camaro	2016	2019			March 1, 2019	LGZ			M5T
	Colorado	2017	2019							
	Corvette	2015	2019			EOP	L83, L86, L8B			M5U, M5X
	Silverado Models	2015	2018		March 1, 2019			LGZ	M5T	
GMC	Canyon	2017	2019			EOP	L83, L86, L8B			M5U, M5X
	Sierra Models	2015	2018							
	Yukon Models	2015	2017							

<b>Involved Region or Country</b>	United States, Canada, Middle East Operations (MEO)
<b>Condition</b>	<p>Some customers may comment on any of the following conditions:</p> <ul style="list-style-type: none"> <li>A shake and/or shudder during light throttle acceleration between 25 and 80 mph (40 and 128 km/h) steady state driving when transmission is not actively shifting gears.</li> <li>A shudder feeling that may be described as driving over rumble strips or rough pavement.</li> </ul> <p>Shudder feeling is evident in both Drive and M7 (MY15-16) and L7 (MY17/MY18) mode.</p>

## Diagnosis Instructions

To ensure torque converter clutch (TCC) shudder is diagnosed correctly, please drive the following schedule on a smooth road with transmission sump temperature between 50°C (122°F) - 70°C (158°F).

**Important:** For some road conditions, it may be required to apply the brake pedal and throttle simultaneously to stay within desired gear, engine firing mode, engine torque range, and engine/vehicle speed ranges.

**For Full Size Trucks/SUVs** - Press and hold the tow-haul mode button for 5 seconds to disable grade braking to prevent downshifts during test.

## Run the following tests for 3 operational modes:

- A. Normal Operation (GDS2 for viewing only)
- B. GDS2 Commanding TCC in Disabled Operation (TCC Open)
- C. GDS2 Commanding TCC in Enabled Operation (TCC Locked)

## Shudder Test

Refer to the table below for conditions pertaining to specific applications. In each vehicle, constant throttle input on a smooth grade is desirable. PicoScope Measured Frequency is the approximate vibration frequency where TCC shudder can be found, discussed in detail below.

Vehicle Information					Shudder Test Conditions					PicoScope
Make	Application:	Engine Type	Engine RPO	Trans RPO	Gear	Engine Mode (4, V6, V8)	Transmission Input Speed (rpm)	Vehicle Speed mph (km/h)	Engine Torque (Nm)	Measured Frequency (+/- 2 Hz)
Cadillac	CTS	6 CYL. NA	LGX	M5N	8	V6	1100-1500	42-55 (67-88)	100-250	23
Cadillac	CTS	4 CYL. Turbo	LTG	M5N	8	4	1100-1500	42-55 (67-88)	100-250	23
Cadillac	CTS-V	8 CYL. Super-charged	LT4	M5U	8	V8	1000-1500	42-62 (67-99)	200-375	28
Cadillac	ATS	4 CYL. NA	LCV	M5T	8	4	1100-1500	42-55 (67-88)	100-250	23
Cadillac	ATS	6 CYL. NA	LGX	M5N	8	V6	1100-1500	42-55 (67-88)	100-250	23
Cadillac	ATS	4 CYL. Turbo	LTG	M5N	8	4	1100-1500	42-55 (67-88)	100-250	23
Cadillac	ATS-V	6 CYL. Twin Turbo	LF4	M5U	8	V6	1100-1500	42-55 (67-88)	150-300	26
Cadillac	CT6	6 CYL. Twin Turbo	LGW	M5X	8	V6	1100-1500	42-55 (67-88)	150-300	26
Cadillac	CT6	6 CYL. NA	LGX	M5N	8	V6	1100-1500	42-55 (67-88)	100-250	23
Cadillac	CT6	4 CYL. Turbo	LTG	M5N	8	4	1100-1500	42-55 (67-88)	100-250	23
Chevrolet	Camaro	6 CYL. NA	LGX	M5T	8	V6	1100-1500	42-55 (67-88)	100-250	23
Chevrolet	Camaro	4 CYL. Turbo	LTG	M5T	8	4	1100-1500	42-55 (67-88)	100-250	23
Chevrolet	Camaro SS	8 CYL. NA	LT1	M5U	8	4/V8	1000-1,500	40-55 (64-88)	(V4) 100-200 / (V8) 175-375	28
Chevrolet	Corvette	8 CYL. NA	LT1	M5U	8	4 (Eco Driving Mode)	1000-1800	40-80 (64-128)	125-250	28
Chevrolet	Corvette Z06	8 CYL. Super-charged	LT4	M5U	8	4 (Eco Driving Mode)	1000-1800	40-80 (64-128)	125-250	28
Chevrolet/GMC	Silverado/Sierra	8 CYL. NA	L83	M5U	8	V8	1050-1500	45-55 (72-88)	200-375	26

Chevrolet/ GMC	Silverado/ Sierra	8 CYL. NA BAS	L8B	M5X	8	V8	1050-1500	45-55 (72-88)	200-375	26
Chevrolet/ GMC/ Cadillac	Silverado/ Sierra/ Yukon	8 CYL. NA	L86	M5U	8	V8	1050-1500	45-55 (72-88)	200-375	26
	Denali/ Denali XL/ Escalade/ ESV									
Chevrolet/ GMC	Colorado/ Canyon	6 CYL. NA	LGZ	M5T	8	V6	1100- 1500	42-55 (67-88)	150-250	25

**GDS Test**

**Important:** Confirmation of TCC shudder should be completed using GDS or a PicoScope.

To confirm TCC shudder, the vibration concern must be created in normal operation (Mode A) of the test. If the concern is gone with the TCC disabled (Mode B, TCC Open) and is gone with TCC enabled (Mode C, TCC Locked), then the vibration root cause is TCC shudder, and the fluid flush procedure corrective action described below should be performed.

If the concern is not present in Mode A, then the vibration concern is NOT TCC shudder.

If the concern is still present with the TCC disabled (Mode B) or with the TCC enabled (Mode C, TCC slip speed at zero), then the vibration root cause is NOT TCC shudder.

GDS can be used to monitor TCC slip to confirm TCC shudder. Once TCC shudder is duplicated, TCC slip speed should be monitored while driving at a steady speed and steady throttle. TCC shudder typically will present itself in an erratic saw tooth or oscilloscope pattern where TCC slip will increase and decrease rapidly. The increase may be as much as a 100 rpm and decline to near 0 rpm, creating a saw tooth type pattern. When TCC slip speed is graphed on the GDS screen, desirable slip speed would present itself with 5 to 40 rpm variation. Slip speed will vary by application. Some performance models will have slip speed in the range of 0 to 10 RPM while some passenger cars and light duty trucks may have 20-30 rpm of slip. The slip speed should be consistent and not erratic, presented in a saw tooth or oscilloscope pattern.

Vibrations not identified as TCC shudder should be further investigated using the Vehicle Vibration Diagnosis in SI as a starting point.

**PicoScope Test**

The PicoScope (CH-51450) essential tool and NVH software or GDS must be used to confirm TCC shudder, engine, tire or driveline component related conditions.

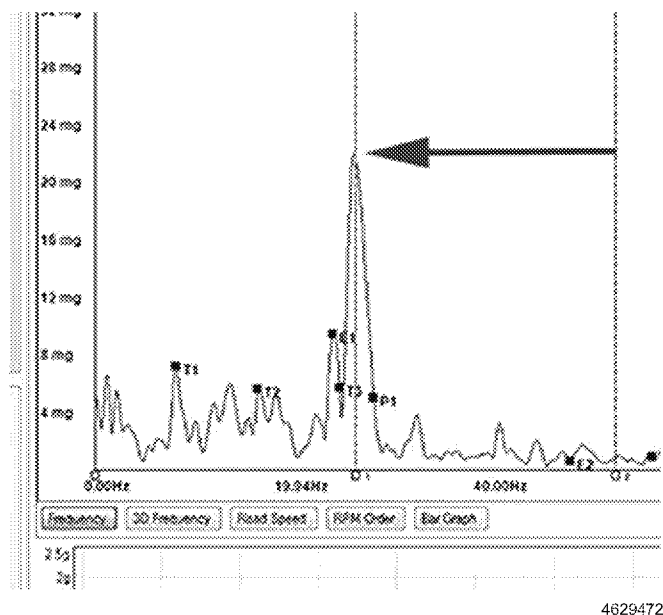

To confirm TCC shudder, record the PicoScope data while driving in 8th gear in the application specific condition above. Minimize extraneous vibration input by testing on a smooth road and correct any other known vehicle vibration issues (tires, brakes, etc.) before conducting test. If TCC shudder is present, a vibration peak will appear (highlighted by arrow below) within +/-2 Hz of the frequency listed in the table above. TCC shudder vibration frequency is stationary in 8th gear. If the vibration frequency follows vehicle speed or engine speed, then it is NOT TCC shudder.

In the above illustration, frequency and default view have been selected.

**Important:** Obtain a single page screen print from GDS or PicoScope that shows the TCC shudder event. This screen print must be attached to the Repair Order hard copy for reference. A screen print can be completed by pressing the Print Screen button on your laptop computer or by using a program or application such as Snipping Tool.

Examples of acceptable screen prints:

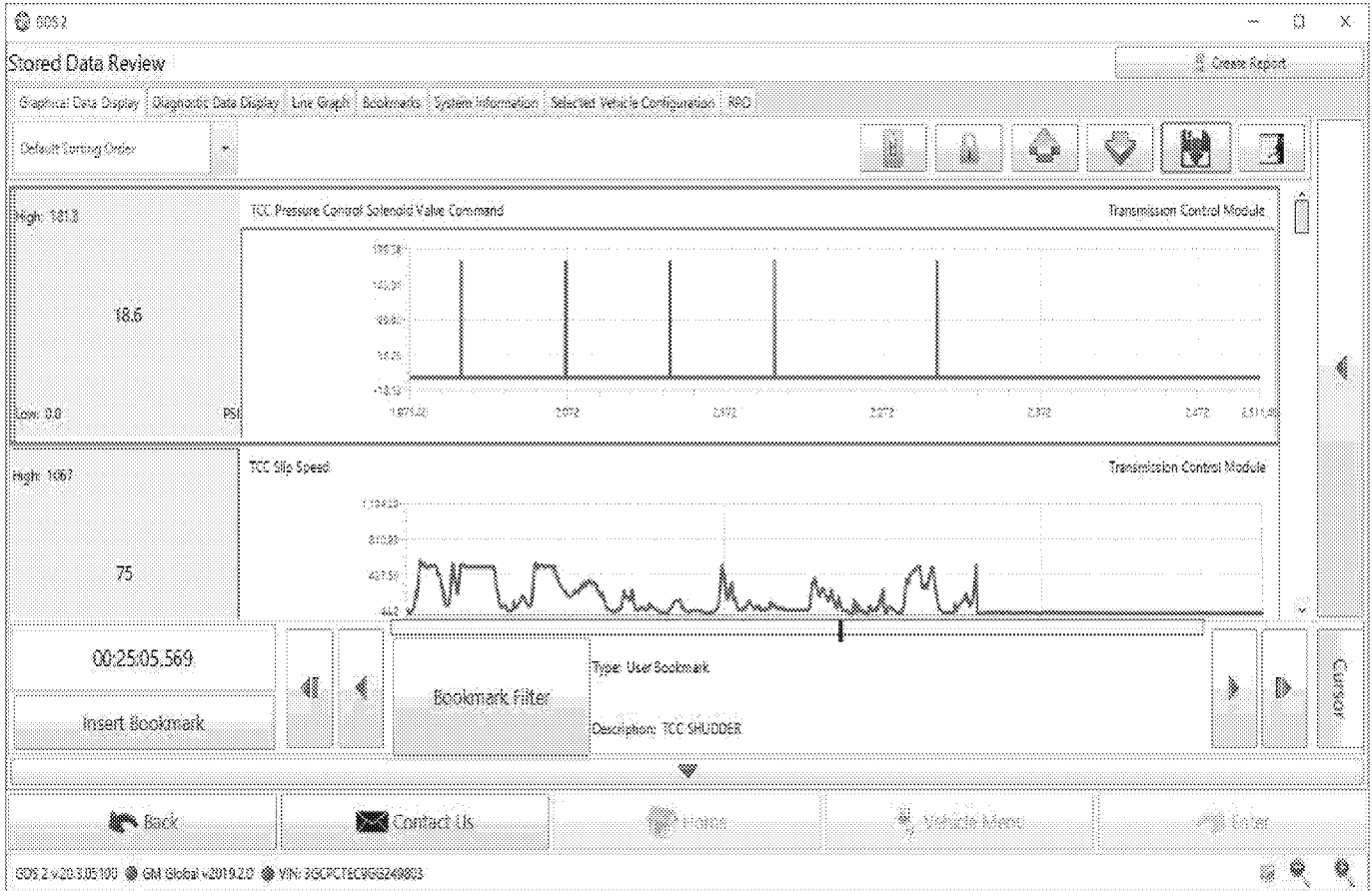

5336317

- GDS2 Session showing TCC slip
- GDS2 Special Functions showing TCC Locked Slip Speed

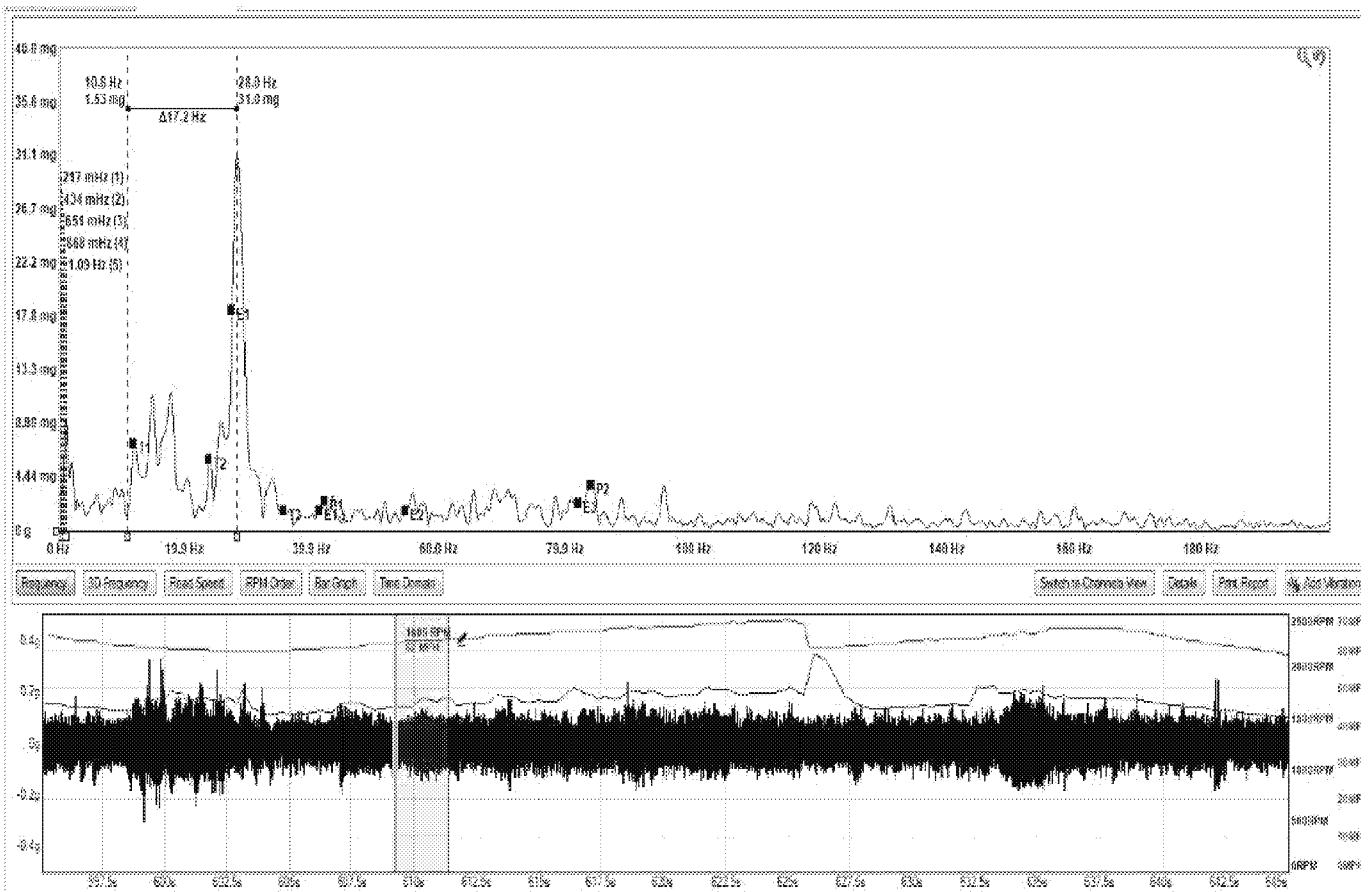

5336322

- PicoScope screen print showing TCC shudder (vibration frequency) in the graphic above.

- DT-52263-4 3/8" Hose Adapter (6" long with 2 hose clamps)
- DT-52263-5 Radiator Cooler Drain Adapter

**Special Tools**

**DT-52263 Transmission Fluid Exchange Kit:**

- DT-52263-1 Block Assembly (includes fluid drain hose, spring clamp)
- DT-52263-2 Cooler Line Plug (qty 3) (use with rear differential cooler and Camaro V8 non rear differential cooler)
- DT-52263-3 1/2" Cooler Line Flush Adapter for 2019 Silverado and Sierra

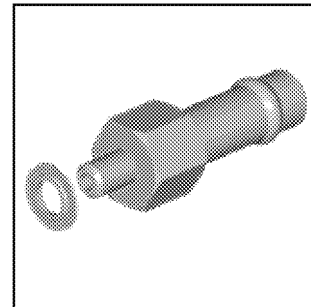

3763203

- DT-51190 Transmission Oil Fill Adapter

### Service Procedure

#### Initial TransFlow Flush Machine Setup

**Important:** The prepping procedure only needs to be completed if the DT-45096 supply reservoir has DEXRON VI fluid in it and has not been converted to use the new blue label Mobil 1 Synthetic LV ATF HP fluid.

**Note:** The prepping procedure only needs to be completed if HP fluid is not in the supply reservoir.

1. Connect the TransFlow adapter DT-45096-31 to the supply line of the DT-45096 TransFlow machine.



5181938

- GE-47716-2 Graduated Bucket



5180884

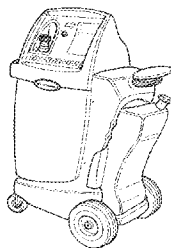

1215917

DT-45096 TransFlow Cooler Flush Machine

2. Switch the DT-45096 TransFlow to Idle.
3. Connect power leads to the vehicle 12-volt DC supply.
4. Turn the TransFlow main switch ON.
5. Connect air supply to the DT-45096.
6. Place the TransFlow supply hose with adapter DT-45096-31 into a waste reservoir using care not to spill the expelled fluid.
7. Switch the DT-45096 TransFlow to Flow and allow all the fluid in the supply reservoir to be removed and placed in the waste reservoir.
8. Switch the control switch back to idle.

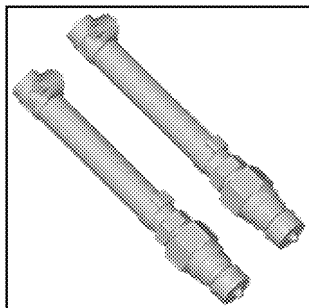

4733125

DT-45096-31 TransFlow Adapter (one of two pieces from DT-45096-30)

## Fluid Exchange Procedure - Colorado, Canyon, Silverado, Sierra, Yukon Denali and Escalade Models with an Accessible Transmission Oil Cooler Line Block Assembly

**Important:** This procedure must be followed as published. The exchange process is required to obtain proper level of new blue label Mobil 1 Synthetic LV ATF HP fluid. Intermixing of other types of transmission fluid or aftermarket additive packages will result in a low concentration level of new fluid and will not provide satisfactory results.

1. Fill the DT-45096 with 20 quarts of HP fluid.
2. Raise the vehicle on a hoist.

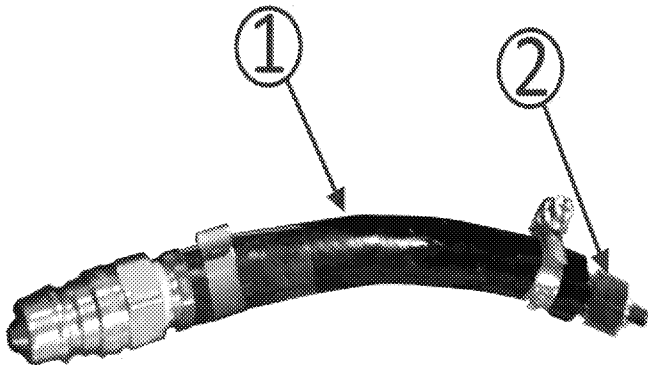

5182541

3. Install the DT-45096-31 TransFlow adapter (1) to the DT-51190 fluid fill adapter (2).

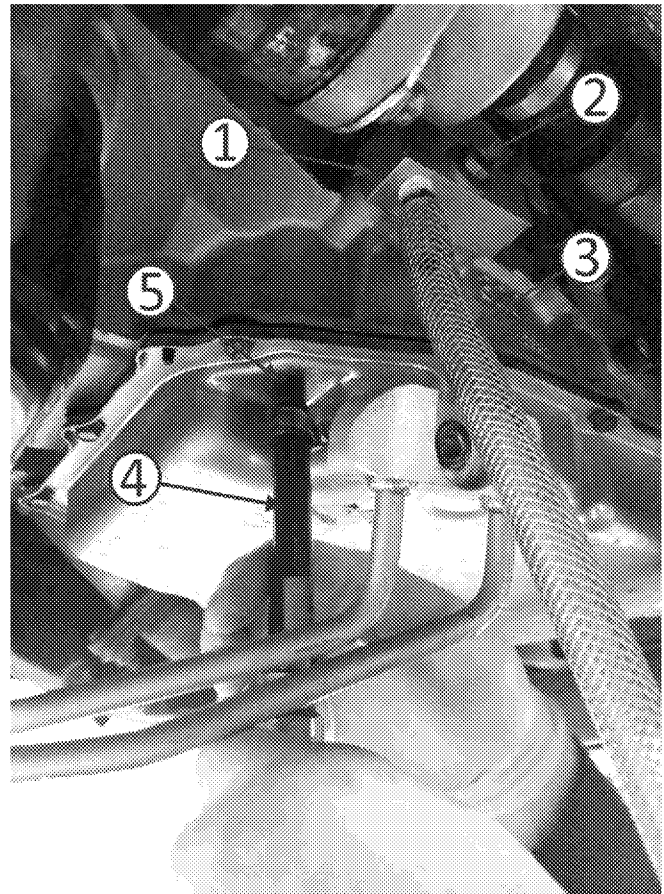

5180563

4. Remove the transmission oil cooler pipe assembly from the transmission.
5. Install the DT-52263-1 Adapter Block Assembly (1), reusing the seal from the transmission oil cooler pipe assembly.
6. Tighten the bolt (2) to 22 N•m (16 lb ft).
7. Place the hose (3) in the GE-47716-2 Graduated Measuring Bucket, utilizing a Spring Clamp to retain the hose.

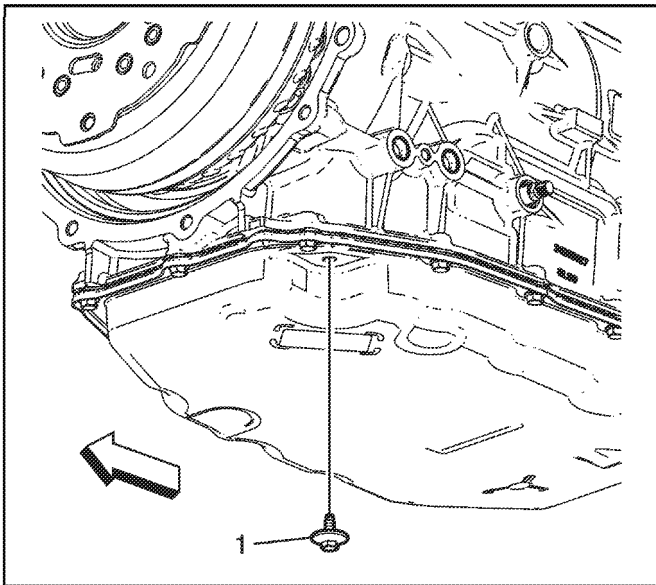

3723844

8. Remove the level set plug (1) from the transmission.

**Important: DO NOT** over tighten the DT-51190 as it can be damaged by excessive torque. **DO NOT** exceed 9 N•m (80 lb in).

9. Install the DT-51190/DT-45096-31 assembly and hand tighten as shown in the graphic above.

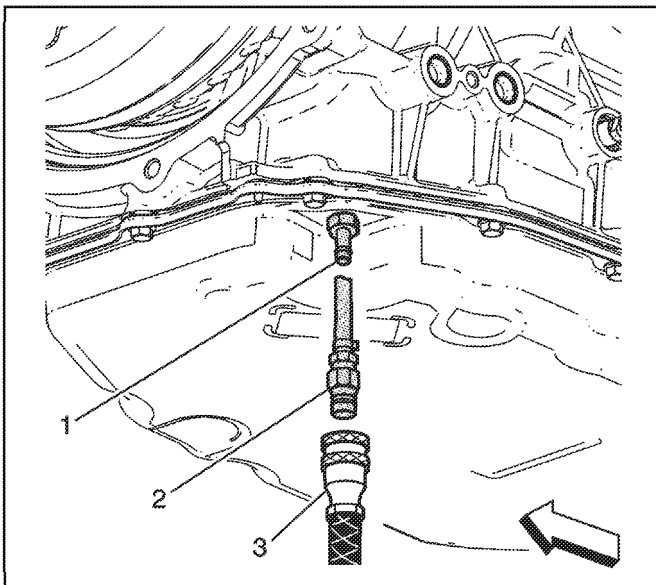

3723839

10. Connect the TransFlow fluid feed (supply) line (3) to the DT-45096-31 adapter (2).

11. Lower the vehicle.

**Caution: DO NOT REMOVE MORE THAN 3 QUARTS OF FLUID AS IT COULD CAUSE FLUID PUMP CAVITATION AND POSSIBLY DAMAGE THE TRANSMISSION.**

12. Utilizing the graduated bucket, start the engine and run 30-45 seconds until 3 quarts of fluid is expelled.

13. Shut the engine off immediately.  
14. Connect the DT-45096 to the vehicle battery 12 volts and connect shop air to the air connection.

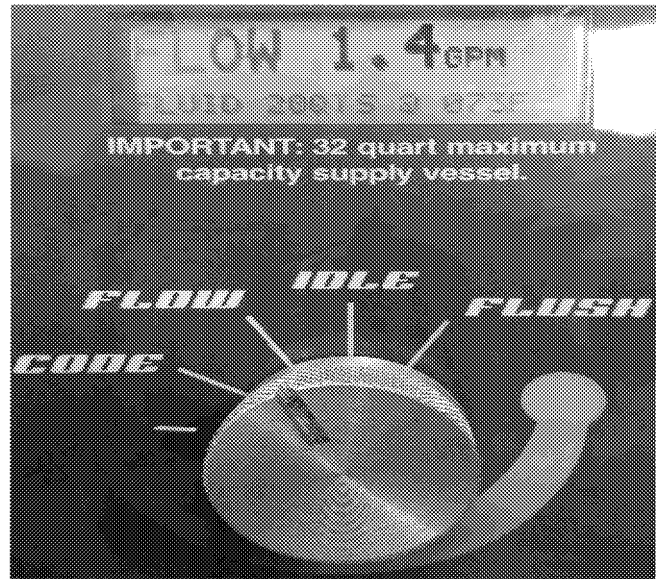

5181027

15. Switch the DT-45096 TransFlow to Flow and add 4 quarts of HP to the transmission.

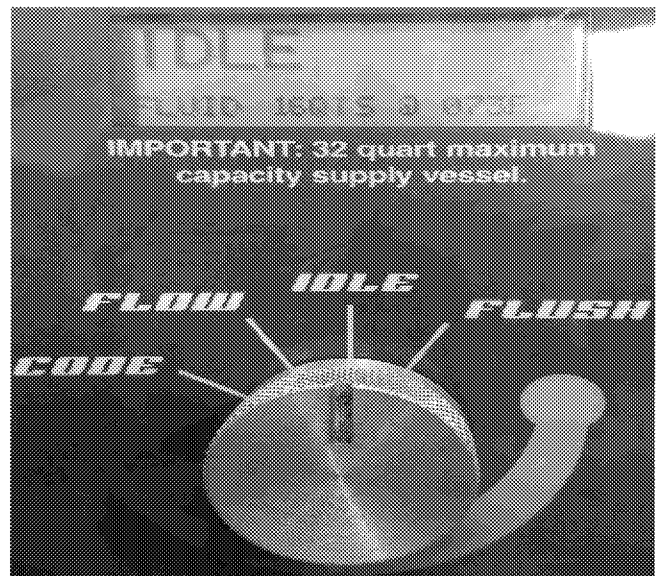

5181020

16. Switch the DT-45096 TransFlow to Idle (Reducing fluid level in the TransFlow from 20-16).  
17. Switch the TransFlow DT-45096 to Flow and start the engine:  
17.1. Add a maximum of 4 quarts of HP Fluid to the transmission, turn the TransFlow switch to idle once 4 quarts have been added, while allowing 4 additional quarts of oil to fill the DT-graduated bucket (Reducing fluid level in the TransFlow from 16 - 12).

**Note:** DO NOT add additional transmission fluid until the 4 quarts of oil have been removed from the transmission (Reducing fluid level in the TransFlow from 12–8).

17.2. Repeat step 17.1.

17.3. Add a maximum of 5 quarts of HP fluid to the transmission while allowing 5 additional quarts of oil to fill the DT-graduated bucket (Reducing fluid level in the TransFlow from 8–3).



5181401

17.4. Shut the engine off once 16 quarts of fluid have been collected.

17.5. Properly dispose of the expelled transmission fluid.

18. Raise the vehicle.

19. Disconnect the DT-45096 TransFlow feed (supply) line from DT-45096-31 TransFlow adapter.

20. Using care, remove DT-45096-31/DT-51190 as an assembly.

21. Remove the DT-51190 fluid fill adapter from DT-45096-31 hose.

22. Install the level set plug.

**Tighten**

Tighten the plug to 9N•m (80 lb in).

23. Remove DT-52263-1 Adapter Block Assembly from the transmission.

24. If equipped, remove the Thermal By-Pass Block from the cooler pipes on the Escalade, Silverado, Sierra and Yukon Models.

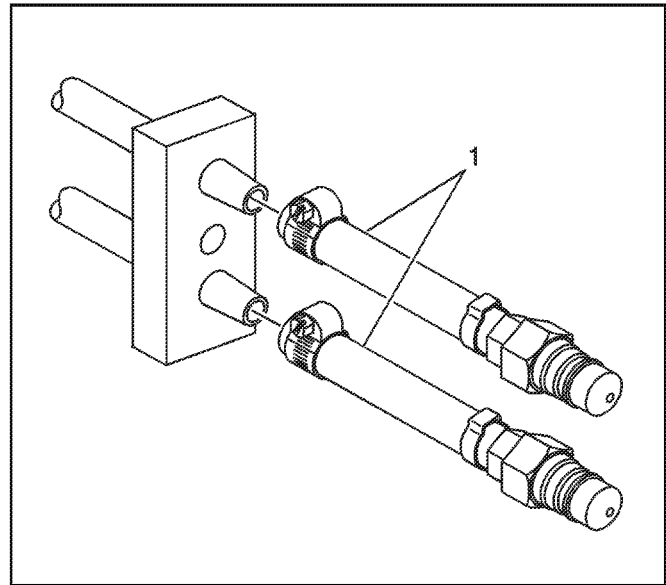

1762577

25. Install DT-45096-31 adapters (1) to the transmission oil cooler lines.

26. Connect the DT-45096 TransFlow to the DT-45096-31 adapters.

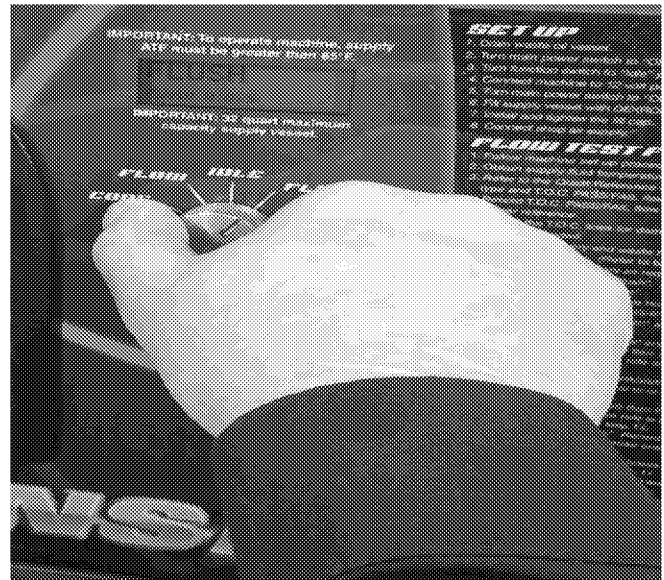

5210461

27. Switch the DT-45096 TransFlow to Flush.

28. Flush the vehicle cooler and lines using 2 quarts of HP fluid.

⇒ Flush 1 quart of fluid through the lines, then switch the hose connections and flush 1 quart of fluid in the opposite direction.

29. Remove the DT-51190/DT-45096-31 assembly.

30. If equipped, install the Thermal By-Pass Block from the cooler pipes on the Escalade, Silverado, Sierra and Yukon Models.

31. Install the transmission oil cooler pipe using a new cooler block seal.
32. Partially lower the vehicle.
33. Start the engine.
34. Using care, shift the transmission through all forward ranges and Reverse.
35. Shift the transmission into Park.
36. Perform the Transmission Fluid Level and Condition Check outlined below in this procedure:
  - 36.1. Get the transmission fluid temperature to the proper temperature.
  - 36.2. Install the level set plug.

**Tighten**

Tighten the plug to 9 N•m (80 lb in).

The TCC shudder condition should be directional improved immediately after the fluid exchange procedure. It may take up to 320 km (200 mi) for the TCC shudder condition to be eliminated. It is not a requirement for the dealer to drive the vehicle 320 km (200 mi). The customer should be advised that the full effect will take up to 320 km (200 mi) and a minimum of two cold to operating temperature drive cycles.

**Fluid Exchange Procedure - Camaro (Except Camaro V8-See Procedure below for Camaro V8), CTS and ATS Not Equipped with a Rear Differential Cooler**

**Important:** This procedure must be followed as published. The exchange process is required to obtain proper level of new blue label Mobil 1 Synthetic LV ATF HP fluid. Intermixing of other types of transmission fluid or aftermarket additive packages will result in a low concentration level of new fluid and will not provide satisfactory results.

1. Fill the DT-45096 with 20 quarts of HP fluid.

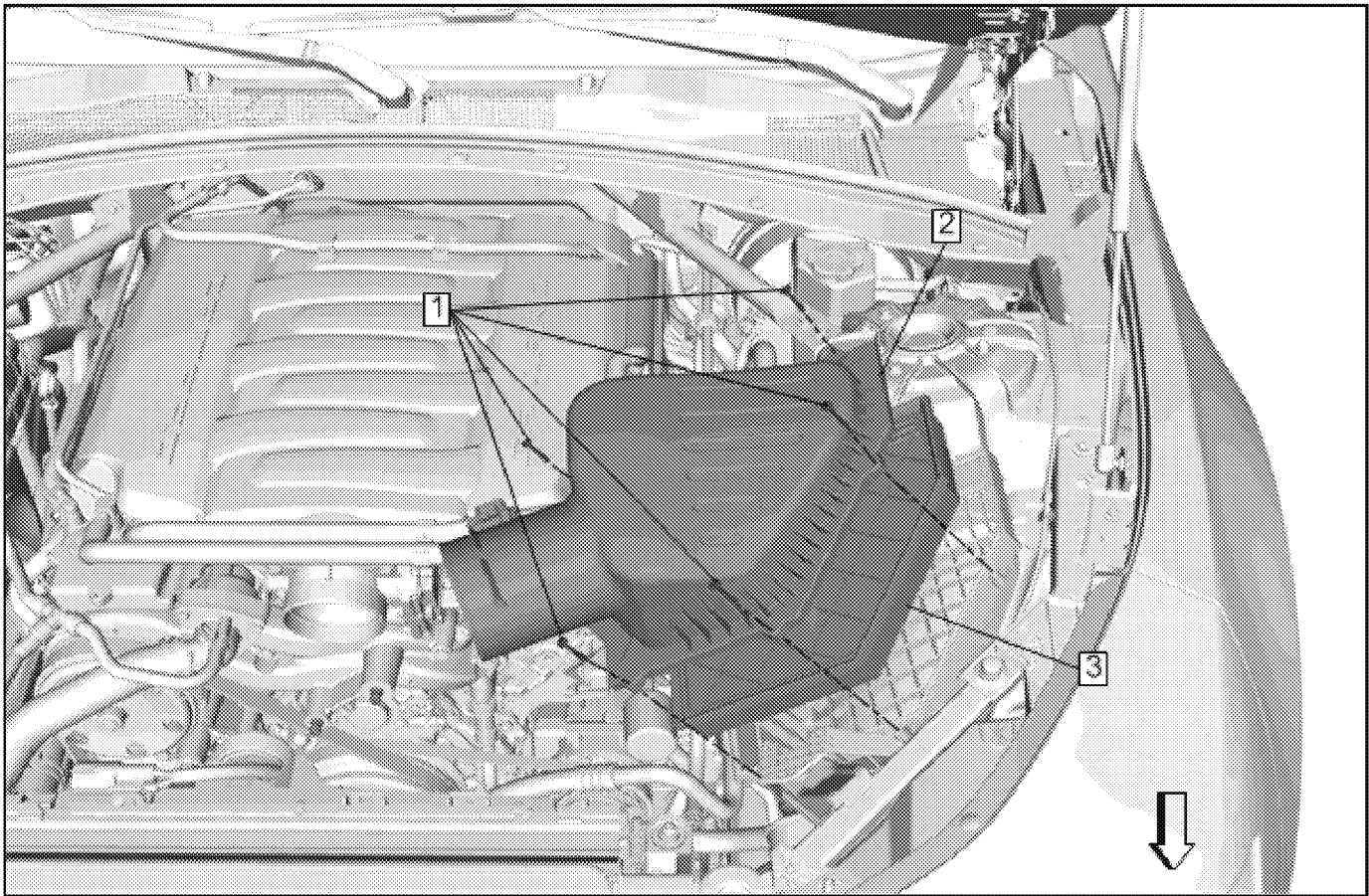

4194576

**Note:** The MAF sensor must stay connected so that no DTCs will set.

2. Separate the engine upper air filter box (1) from the lower air filter housing to gain access to the upper transmission oil cooler line.

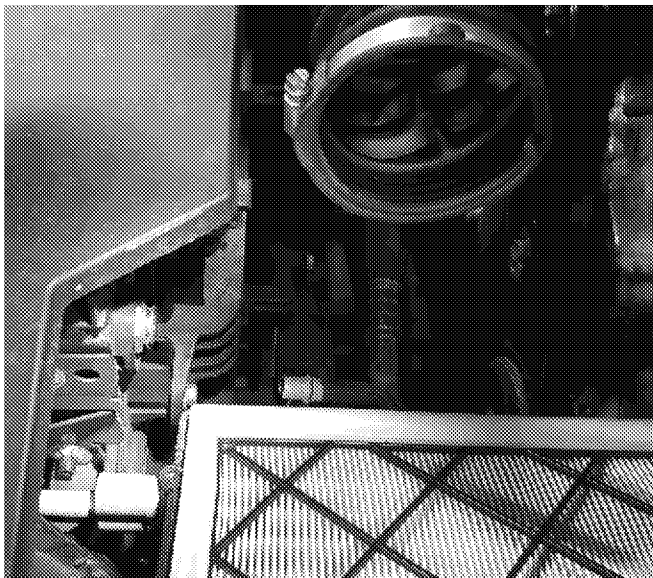

5181307

**Note:** Upper air filter box removed for clarity.

3. Remove the cooler line from the transmission oil cooler.

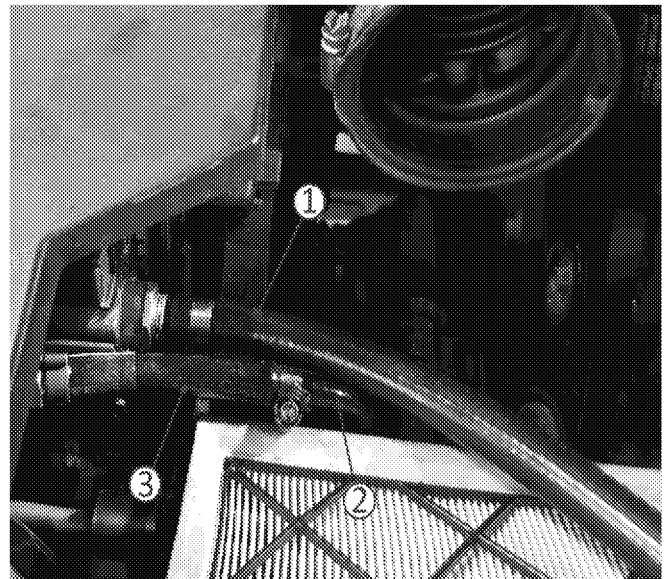

5181322

4. Install end of the DT-52263-5 Radiator Cooler Drain Adapter (1) to the DT-52263-1 Block Assembly.
5. Install the DT-52263-5 Radiator Cooler Drain Adapter into the upper transmission oil cooler line port of the transmission oil cooler.
6. Install the DT-45096-31 adapter (3) over the removed transmission oil cooler line (2) to prevent any fluid spillage.

7. Place the hose in the GE-47716-2 Graduated Measuring Bucket, utilizing a Spring Clamp to retain the hose.
8. Raise the vehicle.

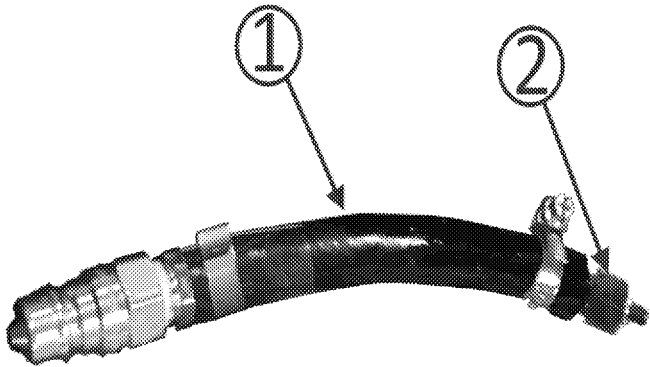

5182541

9. Install the DT-45096-31 adapter (1) to the DT-51190 fluid fill adapter (2).

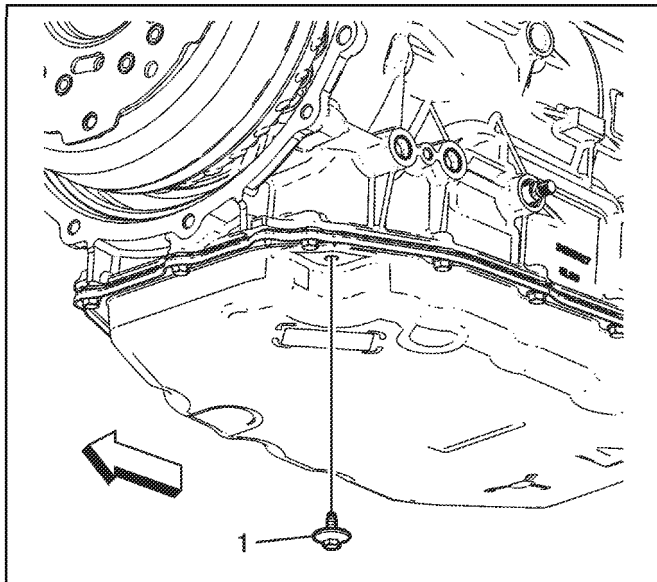

3723844

10. Remove the level set plug (1) from the transmission oil pan.

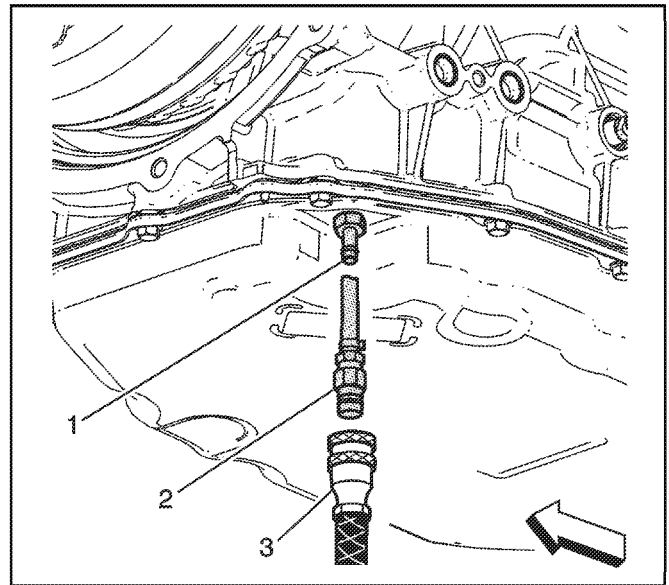

3723839

**Important: DO NOT overtighten the DT-51190 as it can be damaged by excessive torque. Do not exceed 9 N·m (80 lb in).**

11. Install the DT-51190/DT-45096-31 assembly and hand tighten.
12. Connect the TransFlow fluid feed (supply) line (3) to the DT-45096-31 adapter (2).
13. Lower the vehicle.

**Caution: DO NOT REMOVE MORE THAN 3 QTS OF FLUID AS IT COULD CAUSE FLUID PUMP CAVITATION AND POSSIBLY DAMAGE THE TRANSMISSION.**

14. Utilizing the graduated bucket, start the engine and run 30-45 seconds until 3 quarts of fluid is expelled.
15. Shut the engine off immediately.
16. Connect the DT-45096 to the vehicle battery 12 volts and connect shop air to the air connection.

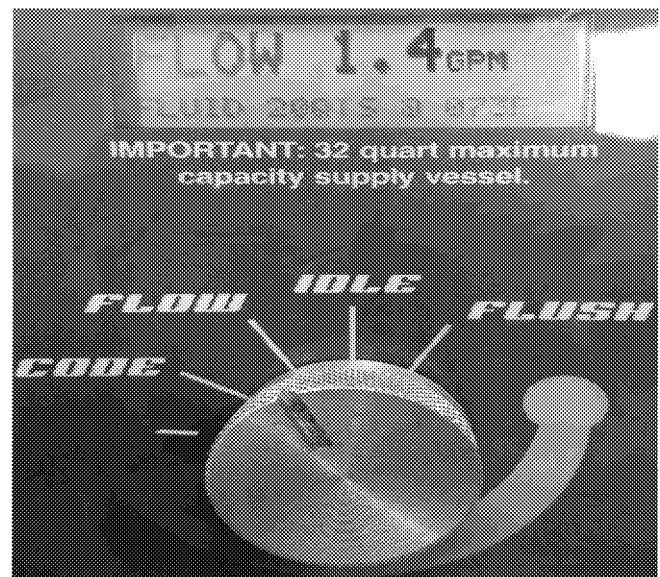

5181027

**Important:** ADDING TOO MUCH FLUID TO THE TRANSMISSION MAY CAUSE FLUID TO BE EXPELLED FROM THE VENT SYSTEM. DO NOT OVERFILL THE TRANSMISSION.

17. Switch the DT-45096 TransFlow to Flow and add 4 quarts of HP to the transmission.

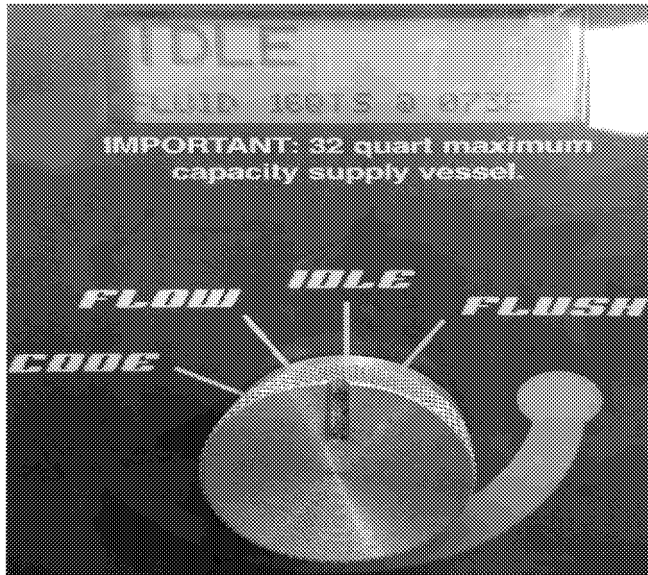

5181020

18. Set the TransFlow switch to idle (Reducing fluid level in the TransFlow from 20–16).
19. Switch the TransFlow DT-45096 to Flow and start the engine:
- 19.1. Add a maximum of 4 quarts of HP Fluid to the transmission, turn the TransFlow switch to idle once 4 quarts have been added, while allowing 4 additional quarts of oil to fill the DT-graduated cylinder (Reducing fluid level in the TransFlow from 16–12).

**Note:** DO NOT add additional transmission fluid until the 4 quarts of oil have been removed from the transmission (Reducing fluid level in the TransFlow from 12–8).

- 19.2. Repeat step 19.1.
- 19.3. Add a maximum of 5 quarts of HP Fluid to the transmission while allowing 5 additional quarts of oil to fill the DT-graduated bucket (Reducing fluid level in the TransFlow from 8–3).



5181401

- 19.4. Shut the engine off once 16 quarts of oil have been collected.
- 19.5. Properly dispose of the collected transmission fluid.
20. Remove the DT-52263-5 Radiator Cooler Drain Adapter and DT-52263-1 Block Adapter from the transmission oil cooler.
21. Remove the DT-45096-31 from the transmission oil cooler line and install the transmission oil cooler line using a new retaining clip.
22. Install the engine upper air filter box back into position.
23. Partially raise the vehicle.
24. Start the engine.
25. Using care, shift the transmission through all forward ranges and Reverse.
26. Shift the transmission into Park.

27. Perform the Transmission Fluid Level and Condition Check outlined below in this procedure:
  - 27.1. Get the transmission fluid temperature to the proper temperature.
  - 27.2. Raise the vehicle and remove the DT-51190/DT-45096-31 assembly.
  - 27.3. Install the level set plug.

**Tighten**

Tighten the plug to 9 N•m (80 lb in).

The TCC shudder condition should be directional improved immediately after the fluid exchange procedure. It may take up to 320 km (200 mi) for the TCC shudder condition to be eliminated. It is not a requirement for the dealer to drive the vehicle 320 km (200 mi). The customer should be advised that the full effect will take up to 320 km (200 mi) and a minimum of two cold to operating temperature drive cycles.

**Fluid Exchange Procedure – Camaro V8 Not Equipped with a Rear Differential Cooler**

**Important:** This procedure must be followed as published. The exchange process is required to obtain proper level of new blue label Mobil 1 Synthetic LV ATF HP fluid. Intermixing of other types of transmission fluid or aftermarket additive packages will result in a low concentration level of new fluid and will not provide satisfactory results.

1. Fill the DT-45096 with 20 quarts of HP fluid.

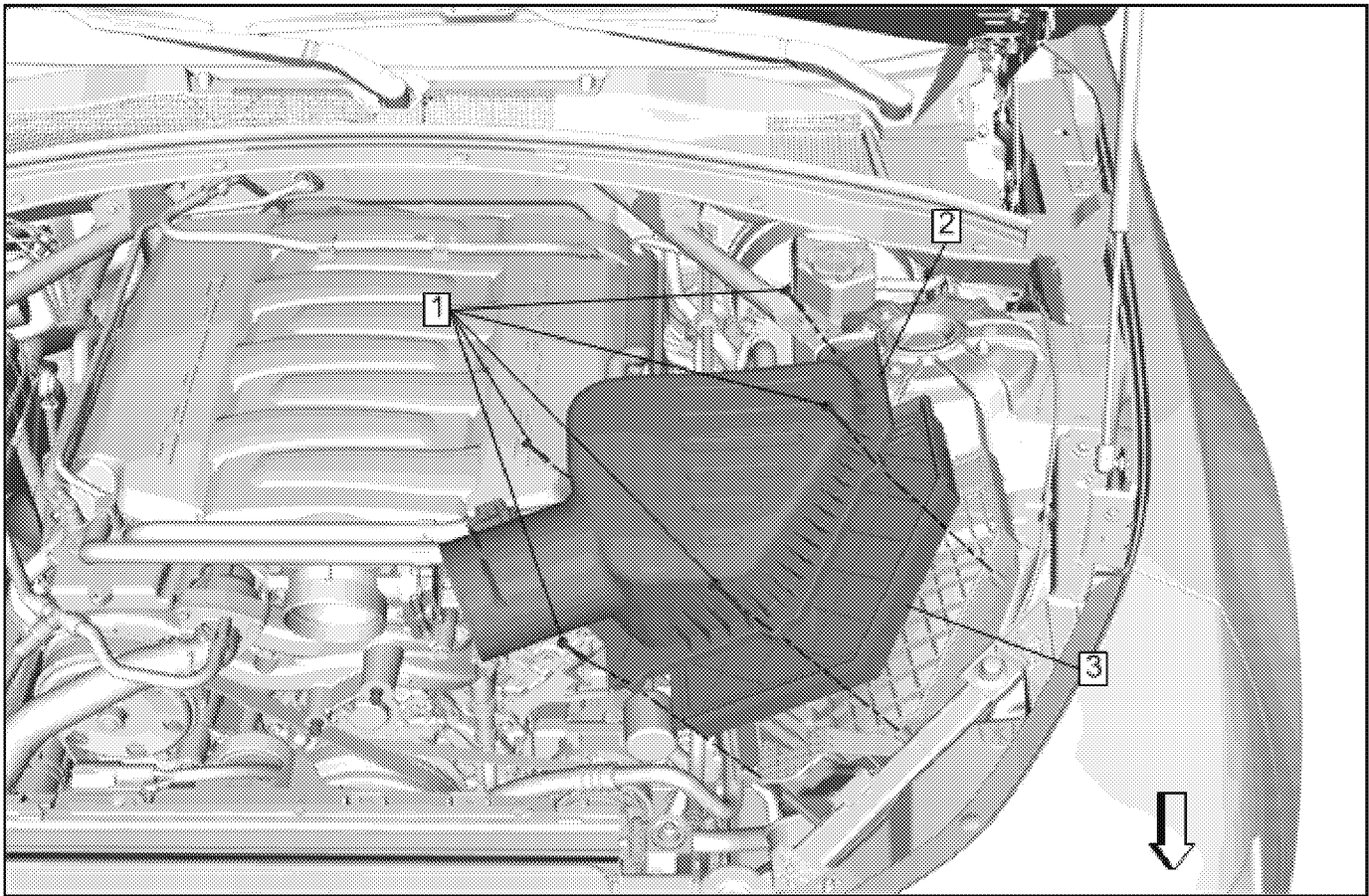

4194576

**Note:** The MAF sensor must stay connected so that no DTCs will set.

2. Separate the engine upper air filter box (1) from the lower air filter housing to gain access to the upper transmission oil cooler line.

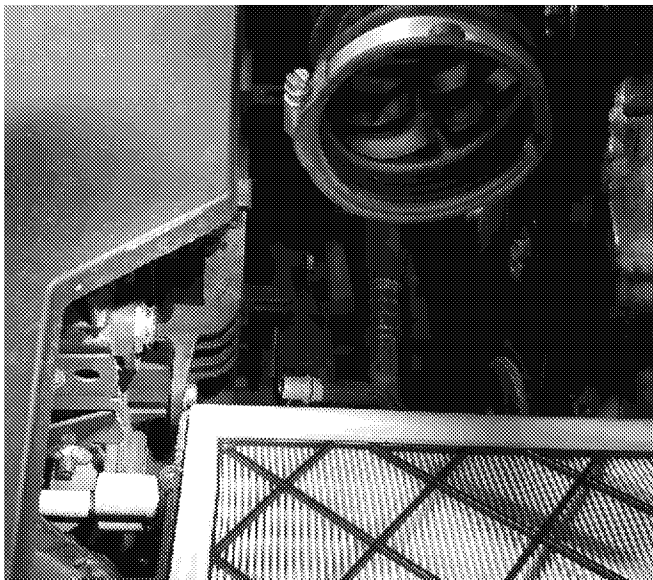

5181307

**Note:** Upper air filter box removed for clarity.

3. Remove the upper cooler line from the transmission oil cooler.

4. Install the DT-52263-2 Cooler Line Plug into the radiator cooler.
5. Install the DT-52263-4 Hose onto DT-52263-1 Block Assembly install the DT-52263-4 onto the removed transmission oil cooler line.
6. Place the hose of the DT-52263-1 in the GE-47716-2 Graduated Measuring Bucket, utilizing a Spring Clamp to retain the hose.
7. Raise the vehicle.

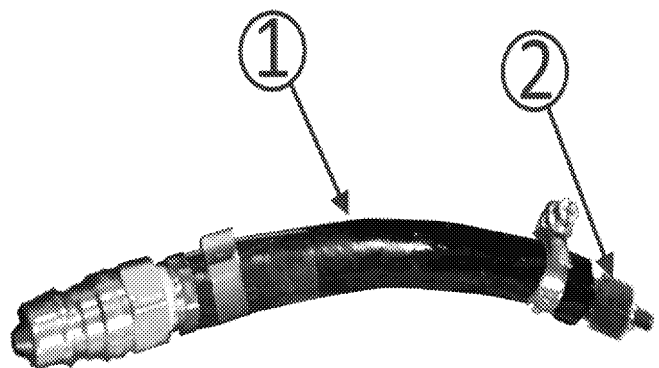

5182541

8. Install the DT-45096-31 adapter (1) to the DT-51190 fluid fill adapter (2).

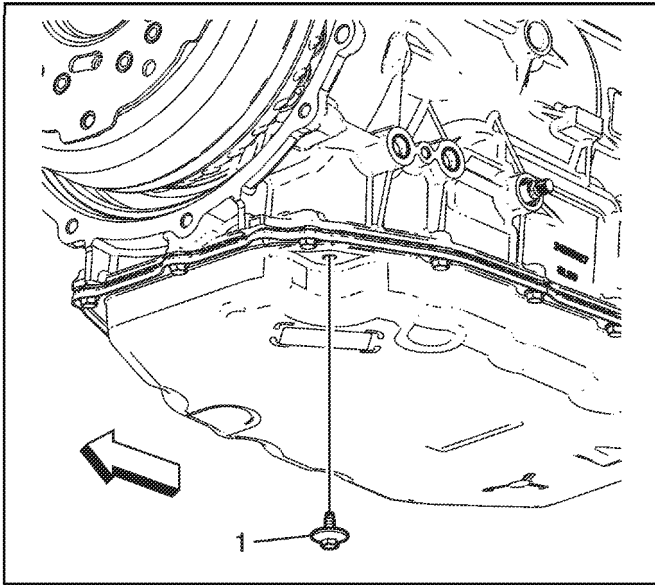

3723844

9. Remove the level set plug (1) from the transmission oil pan.

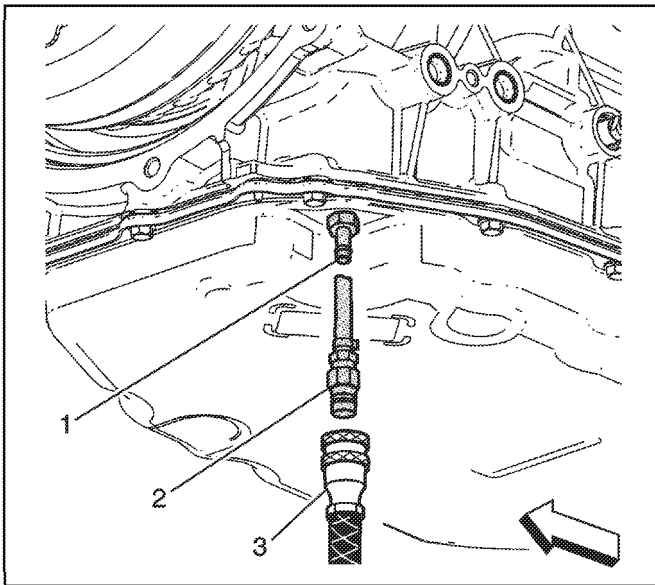

3723839

**Important:** DO NOT overtighten the DT-51190 as it can be damaged by excessive torque. Do not exceed 9 N·m (80 lb in).

10. Install the DT-51190/DT-45096-31 assembly and hand tighten.
11. Connect the TransFlow fluid feed (supply) line (3) to the DT-45096-31 adapter (2).
12. Lower the vehicle.

**Caution:** DO NOT REMOVE MORE THAN 3 QTS OF FLUID AS IT COULD CAUSE FLUID PUMP CAVITATION AND POSSIBLY DAMAGE THE TRANSMISSION.

13. Utilizing the graduated bucket, start the engine and run 30-45 seconds until 3 quarts of fluid is expelled.

14. Shut the engine off immediately.
15. Connect the DT-45096 to the vehicle battery 12 volts and connect shop air to the air connection.

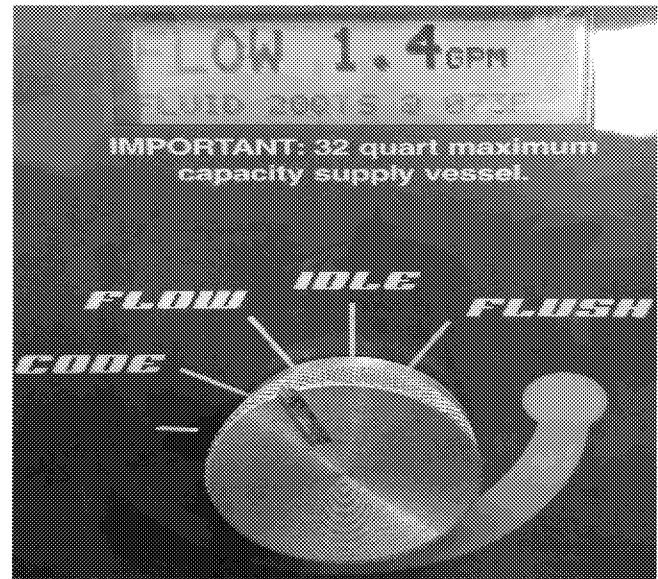

5181027

**Important:** ADDING TOO MUCH FLUID TO THE TRANSMISSION MAY CAUSE FLUID TO BE EXPELLED FROM THE VENT SYSTEM. DO NOT OVERFILL THE TRANSMISSION.

16. Switch the DT-45096 TransFlow to Flow and add 4 quarts of HP to the transmission.

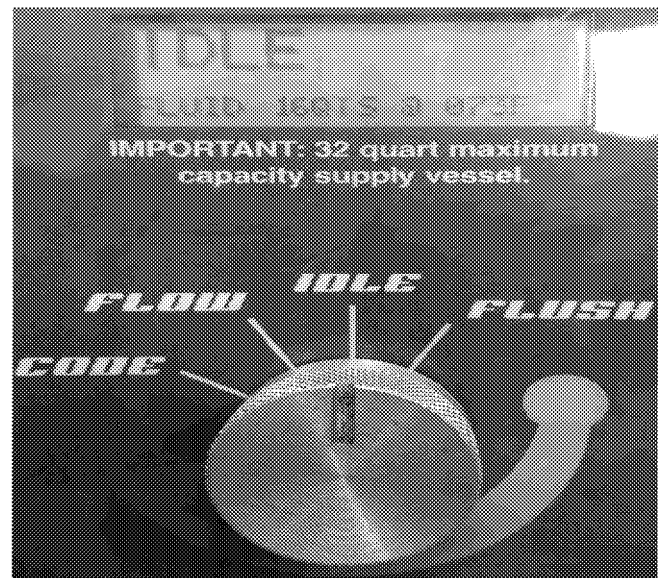

5181020

17. Set the TransFlow switch to idle (Reducing fluid level in the TransFlow from 20-16).

18. Switch the TransFlow DT-45096 to Flow and start the engine:
    - 18.1. Add a maximum of 4 quarts of HP Fluid to the transmission, turn the TransFlow switch to idle once 4 quarts have been added, while allowing 4 additional quarts of oil to fill the DT-graduated cylinder (Reducing fluid level in the TransFlow from 16–12).
- Note:** DO NOT add additional transmission fluid until the 4 quarts of oil have been removed from the transmission (Reducing fluid level in the TransFlow from 12–8).
- 18.2. Repeat step 18.1.
  - 18.3. Add a maximum of 5 quarts of HP Fluid to the transmission while allowing 5 additional quarts of oil to fill the DT-graduated bucket (Reducing fluid level in the TransFlow from 8–3).



5181401

- 18.4. Shut the engine off once 16 quarts of oil have been collected.
  - 18.5. Properly dispose of the collected transmission fluid.
19. Remove the DT-52263-4 and DT-52263-1 Block Adapter from the transmission oil cooler line.
  20. Remove the DT-52263-2 Cooler Line Plug from the transmission oil cooler at the radiator and install the transmission oil cooler line using a new retaining clip.

21. Install the engine upper air filter box back into position.
22. Partially raise the vehicle.
23. Start the engine.
24. Using care, shift the transmission through all forward ranges and Reverse.
25. Shift the transmission into Park.
26. Perform the Transmission Fluid Level and Condition Check outlined below in this procedure:
  - 26.1. Get the transmission fluid temperature to the proper temperature.
  - 26.2. Raise the vehicle and remove the DT-51190/DT-45096-31 assembly.
  - 26.3. Install the level set plug.

### **Tighten**

Tighten the plug to 9 N•m (80 lb in).

The TCC shudder condition should be directional improved immediately after the fluid exchange procedure. It may take up to 320 km (200 mi) for the TCC shudder condition to be eliminated. It is not a requirement for the dealer to drive the vehicle 320 km (200 mi). The customer should be advised that the full effect will take up to 320 km (200 mi) and a minimum of two cold to operating temperature drive cycles.

### **Fluid Exchange Procedure - Camaro, CTS and ATS Equipped with a Rear Differential Cooler**

**Important:** This procedure must be followed as published. The exchange process is required to obtain proper level of new blue label Mobil 1 Synthetic LV ATF HP fluid. Intermixing of other types of transmission fluid or aftermarket additive packages will result in a low concentration level of new fluid and will not provide satisfactory results.

1. Fill the DT-45096 with 20 quarts of HP fluid.
2. Raise the vehicle on a hoist.

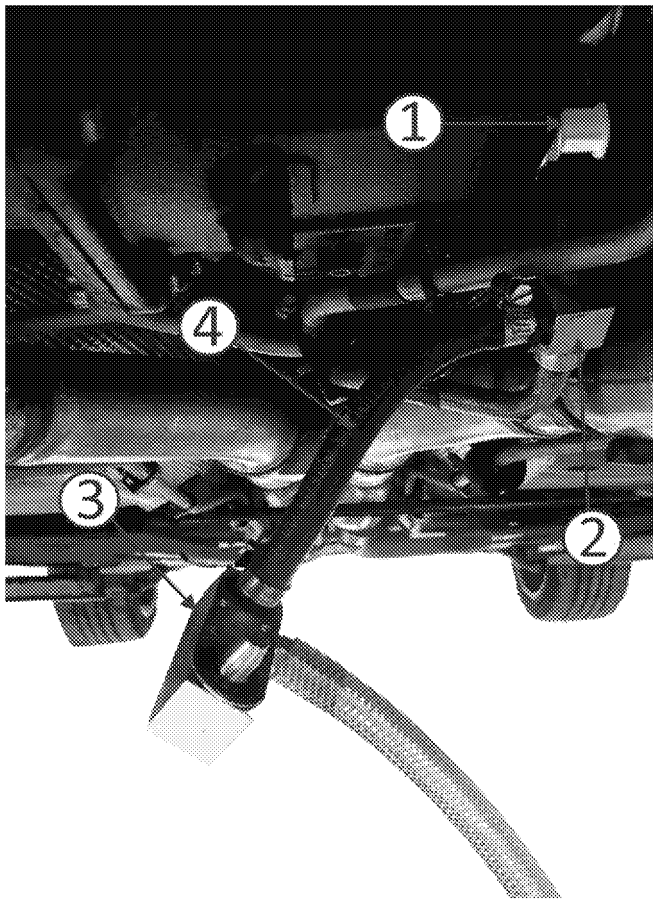

5182245

3. Remove the lower/front transmission oil cooler line (2) at the rear differential.
4. Install the DT-52263-2 Cooler Line Plug (1) into the rear differential to prevent fluid loss.
5. Install one end of the DT-52263-4 hose (4) to the open port of the DT-52263-1 Block Assembly (3).
6. Install the other end of the DT-52263-4 hose to the transmission oil cooler line.
7. Place the hose in the GE-47716-2 Graduated Measuring Bucket, utilizing a Spring Clamp to retain the hose.

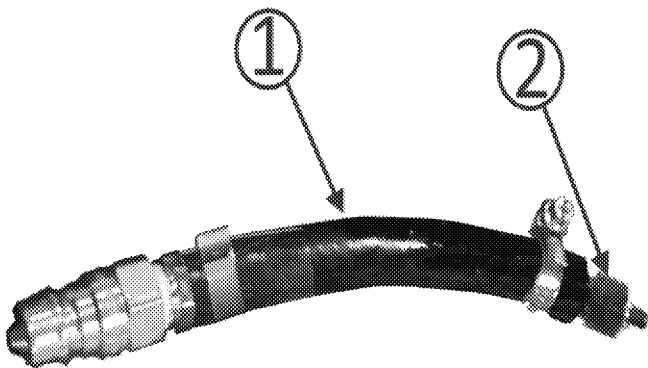

5182541

8. Install the DT-45096-31 adapter (1) to the DT-51190 fluid fill adapter (2).

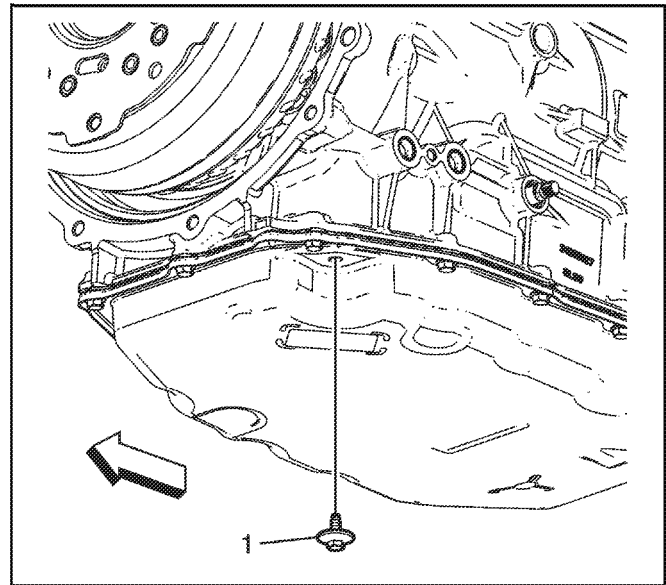

3723844

9. Remove the level set plug (1) from the transmission oil pan.

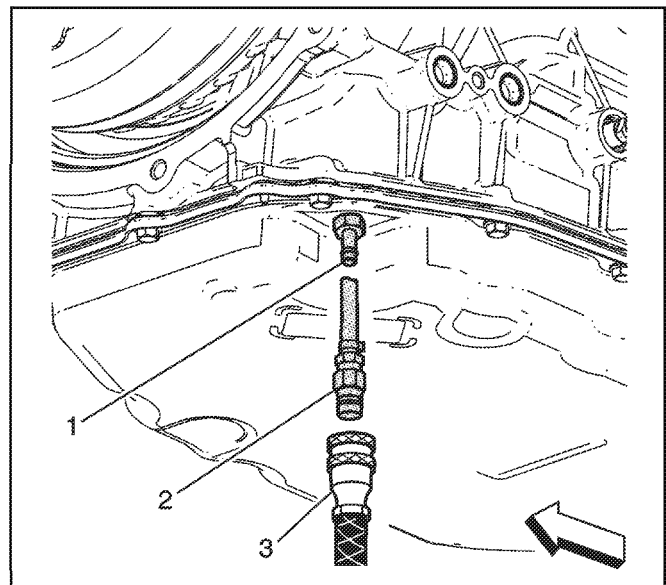

3723839

**Important: DO NOT over tighten the DT-51190 as it can be damaged by excessive torque. Do not exceed 9 N•m (80 lb in).**

10. Install the DT-51190/DT-45096-31 assembly and hand tighten.
11. Connect the TransFlow fluid feed (supply) line (3) to the DT-45096-31 adapter (2).
12. Lower the vehicle.

**Caution: DO NOT REMOVE MORE THAN 3 QTS OF FLUID AS IT COULD CAUSE FLUID PUMP CAVITATION AND POSSIBLY DAMAGE THE TRANSMISSION.**

13. Utilizing the graduated bucket, start the engine and run 30-45 seconds until 3 quarts of fluid is expelled.

14. Shut the engine off immediately.
15. Connect the DT-45096 to the vehicle battery 12 volts and connect shop air to the air connection.

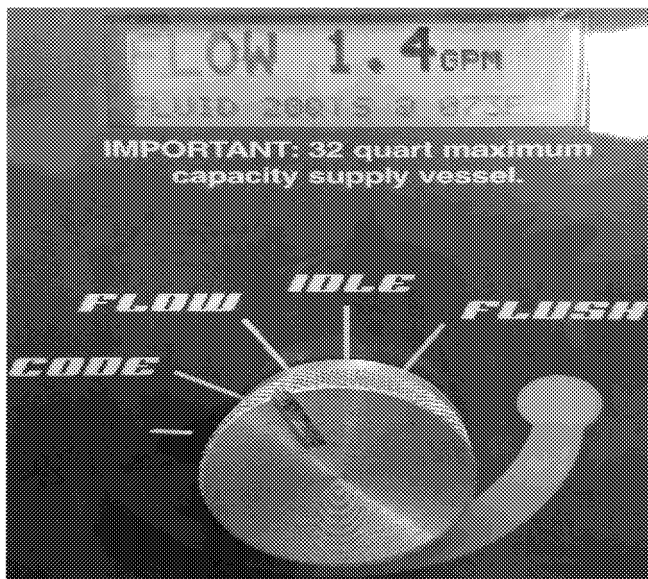

5181027

16. Switch the TransFlow DT-45096 to Flow and add 4 quarts of HP to the transmission.
17. Set the TransFlow switch to idle (Reducing fluid level in the TransFlow from 20–16).
18. Switch the TransFlow DT-45096 to Flow and start the engine:
  - 18.1. Add a maximum of 4 quarts of HP Fluid to the transmission, turn the TransFlow switch to idle once 4 quarts have been added, while allowing 4 additional quarts of oil to fill the DT-graduated bucket (Reducing fluid level in the TransFlow from 16–12).

**Note:** DO NOT add additional transmission fluid until the 4 quarts of oil have been removed from the transmission (Reducing fluid level in the TransFlow from 12–8).

- 18.2. Repeat step 18.1.
- 18.3. Add a maximum of 5 quarts of HP Fluid to the transmission while allowing 5 additional quarts of oil to fill the DT-graduated bucket (Reducing fluid level in the TransFlow from 8–3).



5181401

- 18.4. Shut the engine off once 16 quarts of fluid have been collected.
- 18.5. Properly dispose of the collected transmission fluid.
19. Raise the vehicle.
20. Remove the DT-52263-2 Cooler Line Plug from rear differential and install the transmission oil cooler line using a new retainer clip.
21. Remove the DT-52263-4 from the transmission oil cooler line.
22. Install the transmission oil cooler line using a new retainer clip.
23. Partially lower the vehicle.
24. Using care, shift the transmission through all forward ranges and Reverse.
  - 24.1. Get the transmission fluid temperature to the proper temperature.
  - 24.2. Raise the vehicle and remove the DT-51190/DT-45096-31 assembly.
  - 24.3. Install the level set plug.

#### **Tighten**

Tighten the plug to 9N•m (80 lb in).

The TCC shudder condition should be directional improved immediately after the fluid exchange procedure. It may take up to 320 km (200 mi) for the TCC shudder condition to be eliminated. It is not a requirement for the dealer to drive the vehicle 320 km (200 mi). The customer should be advised that the full effect will take up to 320 km (200 mi) and a minimum of two cold to operating temperature drive cycles.

### Fluid Exchange Procedure - Corvette and CT6

**Important: The Drain and Fill Procedure Will Need to be Performed Three Times.**

**important:** This procedure must be followed as published. The exchange process is required to obtain proper level of new blue label Mobil 1 Synthetic LV ATF HP fluid. Intermixing of other types of transmission fluid or aftermarket additive packages will result in a low concentration level of new fluid and will not provide satisfactory results.

1. Fill the DT-45096 with 24 quarts of HP fluid.
2. Raise the vehicle.
3. Using care, remove the transmission oil pan and drain the transmission fluid.
4. Install the transmission oil pan.

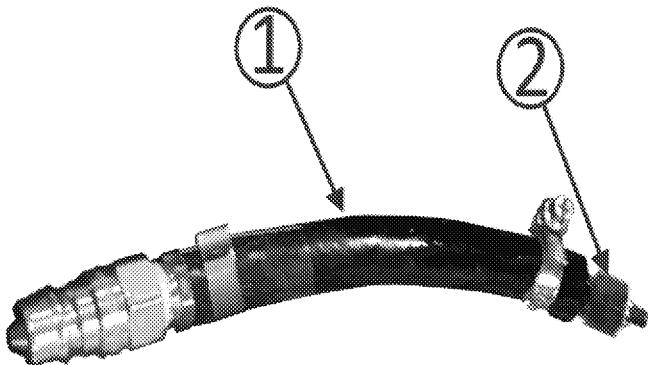

5182541

5. Install the DT-45096-31 adapter (1) to the DT-51190 fluid fill adapter (2).

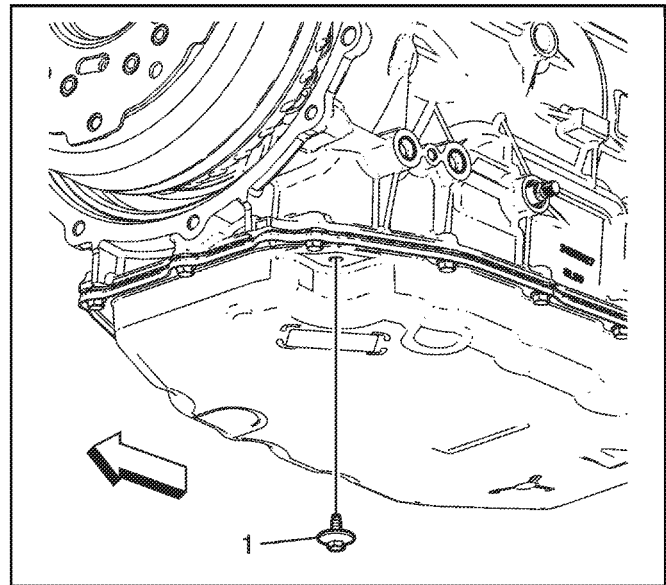

3723844

6. Remove the level set plug (1) from the transmission oil pan.

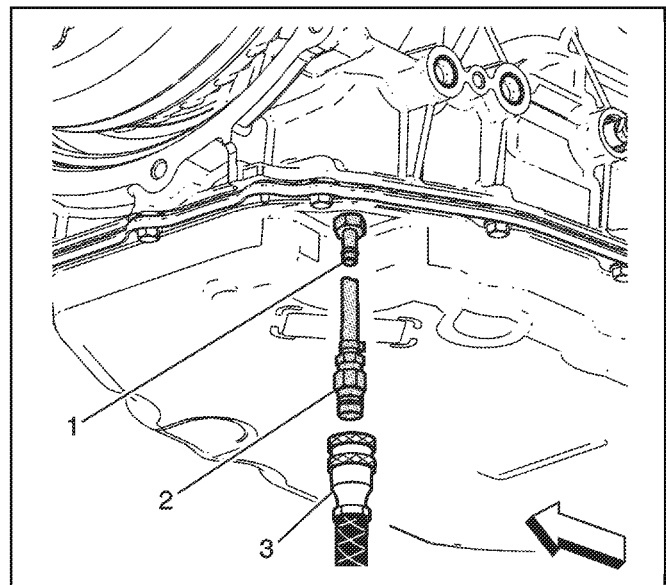

3723839

**Important: DO NOT over tighten the DT-51190 as it can be damaged by excessive torque. Do not exceed 9 N•m (80 lb in).**

7. Install the DT-51190/DT-45096-31 assembly and hand tighten.
8. Connect the TransFlow fluid feed (supply) line (3) to the DT-45096-31 adapter (2).
9. Connect the DT-45096 TransFlow to the vehicle battery 12 volts and connect shop air to the air connection.
10. Switch the DT-45096 TransFlow to Flow and fill the transmission with 8 quarts of transmission fluid.
  - 10.1. Switch the DT-45096 TransFlow to idle.
11. Partially lower the vehicle and run the transmission through all 8 forward gears, Reverse and Neutral.

12. Repeat steps 2-4 and 9-10 for 2nd drain and fill.
13. Repeat step 2-3, clean the transmission oil pan and magnet, repeat step 4 and step 10-11.
14. Perform the Transmission Fluid Level and Condition Check outlined below in this procedure:
  - 14.1. Get the transmission fluid temperature to the proper temperature.
  - 14.2. Raise the vehicle and remove the DT-51190/DT-45096-31 assembly.
  - 14.3. Install the level set plug.

**Tighten**

Tighten the plug to 9 N•m (80 lb in).

The TCC shudder condition should be directional improved immediately after the fluid exchange procedure. It may take up to 320 km (200 mi) for the TCC shudder condition to be eliminated. It is not a requirement for the dealer to drive the vehicle 320 km (200 mi). The customer should be advised that the full effect will take up to 320 km (200 mi) and a minimum of two cold to operating temperature drive cycles.

**Transmission Fluid Level and Condition Check**

This procedure checks both the transmission fluid level, as well as the condition of the fluid itself. Because the transmission on this vehicle is not equipped with a fill tube and dipstick, a tube in the bottom pan is used to set the fluid level.

**Warning:** *The transmission fluid level must be checked when the transmission fluid temperature (TFT) is between 35–45°C (95–113°F). If the TFT is not within this range, either idle or brake torque the vehicle to raise the fluid temperature, or shut off the vehicle to allow the fluid to cool as required. Setting the fluid level with a TFT outside this range will result in either an under or over-filled transmission. TFT>45°C=under-filled, TFT<35°C=over-filled. An under-filled transmission will cause premature component wear or damage. An over-filled transmission will cause fluid to discharge out the vent tube, possibly causing a fire that may result in serious bodily injury or severe vehicle damage, fluid foaming, or pump cavitation.*

**Note:** Silverado, Sierra, Yukon and Escalade Models equipped with a thermal bypass valve, the transmission fluid level should be checked only after the TFT has reached or exceeded an operating temperature of 90°C (194°F). Once the TFT has reached or exceeded 90°C (194°F), then turn OFF the vehicle and allow the TFT to cool back down to 35-45°C (95-113°F) before checking the fluid level as required. Reaching or exceeding an operating temperature of 90°C (194°F) opens the bypass valve and allows the cooler to fill up with fluid, which will result in a more accurate fluid level check.

1. Observe the TFT using the driver information center (DIC) or a scan tool.
2. Start and idle the engine.

3. Depress the brake pedal and move the shift lever through each gear range.
  - 3.1. Pause for at least 3 seconds in each range.
  - 3.2. Move the shift lever back to PARK.
  - 3.3. Ensure the engine RPM is low (500–800 RPM).
4. Allow the engine to idle for a minimum time of 1 minute.

**Caution:** THE ENGINE MUST BE RUNNING when the trans oil level check plug is removed or excessive fluid loss will occur, resulting in an under-filled condition. An under-filled transmission will cause premature component wear or damage.

5. Raise the vehicle on a hoist.
  - ⇒ The vehicle must be level, with the engine running and the shift lever in the PARK range.

**Note:** Continue to monitor the TFT. If the TFT is not within the specified values, reinstall the trans oil level check plug and repeat the previous steps.

6. Remove the transmission oil level check plug (1) from the transmission fluid pan.
7. Allow any fluid to drain.
  - If the fluid is flowing as a steady stream, wait until the fluid begins to drip.
  - If no fluid comes out, add fluid until fluid drips out. Refer to *Transmission Fluid Fill Procedure* in SI.
8. Reinstall the transmission oil level check plug.

**Tighten**

Tighten the plug to 9 N•m (80 lb in).

9. Inspect for external leaks. Refer to *Fluid Leak Diagnosis* in SI.

**Parts Information**

**Note:** Only select the parts that coincide with the repair performed.

Causal Part	Description	Part Number	Qty
X	Mobil 1 Synthetic LV ATF HP (Available only through Local GM Oil Distributors)	19417577 (US - 1 quart)	20
		19418066 (Canada - 0.946L/1 qt)	24 (CT6, Corvette)
N/A		Drum 55 gallon 19417904 (US)	1
N/A	RETAINER, TRANS FLUID CLR PIPE FTG	24205103	2
N/A	SEAL, TRANS FLUID CLR PIPE	23135703	1

### Warranty Information

For vehicles repaired under the Powertrain coverage, use the following labor operation. Reference the Applicable Warranties section of Investigate Vehicle History (IVH) for coverage information.

Labor Operation	Description	Labor Time
8480818*	Diagnostic Testing and Fluid Exchange	1.4 hrs
Add	CT6 AWD Triple Drain and Fill	1.0 hr
Add	CT6 RWD Triple Drain and Fill	1.6 hrs
Add	Corvette RWD Triple Drain and Fill	1.6 hrs
Add	DT-45096 Prep (Not required unless the fluid is not Mobil 1 Synthetic LV ATF HP)	0.1 hr

\*This is a unique Labor Operation for Bulletin use only.

<b>Version</b>	3
<b>Modified</b>	<p>Released January 17, 2019</p> <p>March 01, 2019 – Added Canada, Middle East Operations, Mexico and Export Region reference to Attention statement, added Canada and Middle East Operations to Involved Region or Country, added printing information to the Important statement under PicoScope Test section and added fluid part number for Canada, a Note and two additional part numbers in the Parts Information section.</p> <p>May 21, 2019 – Added Date Breakpoints in Models section, Fluid Exchange Procedure for V8 Camaro, additional information to TCC Shudder condition paragraph at the end of each procedure, added missing 4 quarts of HP fluid to the vehicles with Rear Differential Cooler sections and added Pico and GDS screen shots.</p>

GM bulletins are intended for use by professional technicians, NOT a "do-it-yourselfer". They are written to inform these technicians of conditions that may occur on some vehicles, or to provide information that could assist in the proper service of a vehicle. Properly trained technicians have the equipment, tools, safety instructions, and know-how to do a job properly and safely, if a condition is described. DO NOT assume that the bulletin applies to your vehicle, or that your vehicle will have that condition. See your GM dealer for information on whether your vehicle may benefit from the information.



WE SUPPORT VOLUNTARY  
TECHNICIAN  
CERTIFICATION